

Approval body for construction products
and types of construction

Bautechnisches Prüfamt

An institution established by the Federal and
Laender Governments



European Technical Assessment

ETA-05/0001
of 30 April 2015

English translation prepared by DIBt - Original version in German language

General Part

Technical Assessment Body issuing the
European Technical Assessment:

Deutsches Institut für Bautechnik

Trade name of the construction product

Euromac 2

Product family
to which the construction product belongs

Non-load bearing permanent shuttering kit "Euromac 2"
based on shuttering elements of EPS

Manufacturer

Euromac 2 SAS
Parc Industriel du Furst
8 Rue Philippe de Consigny
57730 FOLSCHVILLER
FRANKREICH

Manufacturing plant

EUROMAC 2 EUROSTYRENE
Parc Industriel de Furst
Rue Philippe de Consigny
F-57730 Folschviller
FRANKREICH

This European Technical Assessment
contains

19 pages including 11 annexes which form an integral
part of this assessment

This European Technical Assessment is
issued in accordance with Regulation (EU)
No 305/2011, on the basis of

Guideline for European technical approval of "Nonload-
bearing permanent shuttering systems based on hollow
blocks or panels of insulating materials and sometimes
concrete", ETAG 009, June 2002,
used as European Assessment Document (EAD)
according to Article 66 Paragraph 3 of Regulation (EU)
No 305/2011.

**European Technical Assessment
ETA-05/0001**

Page 2 of 19 | 30 April 2015

English translation prepared by DIBt

The European Technical Assessment is issued by the Technical Assessment Body in its official language. Translations of this European Technical Assessment in other languages shall fully correspond to the original issued document and shall be identified as such.

Communication of this European Technical Assessment, including transmission by electronic means, shall be in full. However, partial reproduction may only be made with the written consent of the issuing Technical Assessment Body. Any partial reproduction has to be identified as such.

This European Technical Assessment may be withdrawn by the issuing Technical Assessment Body, in particular pursuant to information by the Commission according to Article 25 Paragraph 3 of Regulation (EU) No 305/2011.

Specific part

1 Technical description of the product

1.1 Definition of product

The shuttering system "EUROMAC 2" is a non-load-bearing permanent shuttering kit based on shuttering elements (see Annexes A1 and A2) and accessory parts (see Annex A3) applicable as formwork for plain and reinforced concrete walls cast in-situ. The accessory parts are end leaves, lintel bottom leaves and capsules.

1.2 Shuttering elements

The shuttering elements consist of one-layered expanded polystyrene (EPS) leaves which are prefabricated in connection with ladders of steel. The ladders consist of two flat steels and spacers of steel wire which connect the flat steels. The horizontal distance between the spacers is 150 mm (see h in Annexes A1 and A2). The spacers are fastened to the flat steels by spot welding. In the finished element the vertical distance between the ladders is 150 mm and the flat steels of the ladders are completely enclosed in the EPS (expanded polystyrene) of the shuttering leaves.

The upper and lower surfaces of the shuttering leaves are castellated and the vertical mating surfaces are tongue and groove to form a tight fit when joined together. The outer surfaces have tapered grooves running vertically. At the inner surfaces offset to the grooves ribs are situated which serve as mechanical fixing of the shuttering leaves to the concrete. They also form locks for end stops and lintel elements. The dimensions of the elements range from 1000 mm to 1750 mm length and from 200 mm to 600 mm height.

The thickness of the inner shuttering leaf in all cases is 45 mm and the thickness of the outer shuttering leaf ranges from 45 to 245 mm. The minimal thickness of concrete core b_{\min} in most cases is 145 mm with an associated maximum thickness of concrete core b_{\max} of 160 mm. There is only one element with a minimum thickness of concrete core b_{\min} of 195 mm and the associated maximum thickness of concrete core b_{\max} of 210 mm (see Annexes A1 and A2).

Special elements are also part of the kit as angular and end elements (see Annex A2) which are produced in the same manner as described above.

1.3 Accessory parts

1.3.1 End leaves

End leaves are inserted in the gaps between the shuttering leaves at openings of the wall.

1.3.2 Lintel bottom leaves

Lintel bottom leaves shall be inserted in the gaps between the shuttering leaves and form the bottom of a shuttering of a lintel. Before concreting the leaves have to be supported.

English translation prepared by DIBt

1.3.3 Capsule

The capsule according to Annex A3 are made of plastic. They protect the cutting edges of the flat steels against corrosion and personal injury during construction.

2 Specification of the intended use in accordance with the applicable European assessment Document

The kit is intended to be used for construction of internal walls as well as external walls above or below ground which are load-bearing (structural) or non load-bearing (non structural), including those which are subjected to fire regulations.

When using this type of construction below ground a waterproofing according to applicable national rules shall be provided depending on whether water not exerting pressure or water exerting pressure is to be dealt with. The waterproofing shall be protected from mechanical damage by a impact resistant protective layer.

The performances given in Section 3 are only valid if the shuttering elements are used in compliance with the specifications and conditions given in Annex (B).

The verifications and assessment methods on which this European Technical Assessment is based lead to the assumption of a working life of the shuttering kit of at least 50 years. The indications given on the working life cannot be interpreted as a guarantee given by the producer, but are to be regarded only as a means for choosing the right products in relation to the expected economically reasonable working life of the works.

3 Performance of the product and references to the methods used for its assessment

3.1 Mechanical resistance and stability (BWR 1)

3.1.1 Resulting structural pattern

In end use conditions walls made with shuttering elements "EUROMAC 2" are walls of continuous type according to ETAG 009, paragraph 2.2.

3.1.2 Efficiency of filling

Considering the instructions of Annex (B) and the installation guide of the ETA applicant the efficient filling without bursting of the shuttering and without voids or any uncovered reinforcement in the concrete core is possible.

The requirements according to ETAG 009, chapter 6.1.2 are met satisfactory.

3.1.3 Possibility of steel reinforcement

The instructions in the installation guide of the ETA applicant are appropriate to install steel reinforcement for walls according to EN 1992-1-1 or corresponding national rules.

The requirements according to ETAG 009, chapter 6.1.3 are met satisfactory.

3.2 Safety in case of fire (BWR 2)

3.2.1 Reaction to fire

Euroclass F, no performance determined

3.2.2 Resistance to fire

Since the minimum thickness of the continuous concrete core can be rounded up to 150 mm the fire resistance class of walls with a minimum concrete strength C16/20 according to Table 1 of Annex C of ETAG 009 is REI 120.

3.3 Hygiene, health and the environment (BWR 3)

3.3.1 Release of dangerous substances

According to the manufacturer's declaration the shuttering elements "EUROMAC 2" taking account of the EU database¹ does not contain any dangerous substances.

In addition to the specific clauses relating to dangerous substances contained in this European Technical Assessment, there may be other requirements applicable to the products falling within its scope (e.g. transposed European legislation and national laws, regulations and administrative provisions). In order to meet the provisions of the EC Construction Products Regulation, these requirements need also to be complied with, when and where they apply.

3.3.2 Water vapour permeability

The tabulated design value of water vapour diffusion resistance coefficient of expanded polystyrene (EPS), according to EN 12524², is $\mu = 60$.

The values for the water vapour diffusion resistance of concrete in dependence of density and type are tabulated in EN 12524.

3.4 Safety and accessibility (BWR 4)

3.4.1 Bond strength between the shuttering leaves and the concrete core

The expanded polystyrene is bonded to the concrete by mechanical interlocking of the dovetail sections running vertically in the inner surfaces of the shuttering leaves over the whole element height with a horizontal distance of 5 cm. Since the width of the dovetail sections is 15 mm the effective area for transmission of tensile forces is $0,015 \cdot 1 \cdot 20 \text{ m}^2 = 0,3 \text{ m}^2$. This is more than 20 % of the whole area of the shuttering leaves and leads to the effective bond strength of $0,03 \text{ N/mm}^2$ what is sufficient to meet the requirements in ETAG 004, chapter 6.1.4.1.3.

The requirements according to ETAG 009, chapter 6.4.1.3 are met satisfactory.

3.4.2 Resistance to filling pressure

The resistance to filling pressure have been determined by testing of the finished shuttering elements with a pneumatic jack. The material for the shuttering leaves was in accordance with Annex A1 to Annex A3. The minimum value of this failure pressure was at $0,09 \text{ N/mm}^2$.

The requirements according to ETAG 009, chapter 6.4.2 are met satisfactory.

3.4.3 Safety against personal injury by contact

As delivered on site the shuttering elements do not have sharp or cutting edges. At door or window openings some elements may have to be curtailed. Immediately after cutting the elements the plastic capsule has to be put over the cutting edges of the flat steels.

Because of the soft surface of the shuttering leaves there is no risk of abrasion or of cutting to people.

The requirements according to ETAG 009, chapter 6.4.3 are met satisfactory.

3.5 Protection against noise (BWR 5)

3.5.1 Airborne sound Insulation

The "No performance determined" option in ETAG 009, Table 3 is used.

3.5.2 Sound absorption

The "No performance determined" option in ETAG 009, Table 3 is used.

¹ Notes are stated in Guidance Paper H: "A harmonized approach relating to dangerous substances under the Construction Products Directive", Brussels, 18 February 2000

² EN 12524:2000 Building materials and products - Hygrothermal properties - Tabulated design values

English translation prepared by DIBt

3.6 Energy economy and heat retention (BWR 6)

3.6.1 Thermal resistance

The nominal value of the thermal resistance R ($\lambda_d = 0.0329 \text{ W/(m}\cdot\text{K)}$ for the expanded polystyrene) of the elements in end use conditions (with concrete infill) is calculated in accordance with EN ISO 6946³ from the nominal value of the thermal resistance of the shuttering leaves R_{DI} according to EN 13163, chapter 4.2.1, and the thermal resistance of the concrete core R_{DC} . The thermal resistance of the concrete core can be calculated by using the values of thermal conductivity in dependence on density tabulated in EN 12524.

$$R = R_{DI} + R_{DC} - \Delta R \quad [\text{m}^2\text{K/W}]$$

Because of the influence of the steel ladders this value has to be reduced in dependence of the cross section of the wall as given in the following Table.

Type of shuttering element according to Annex 1	Thickness of the internal shuttering leaf (mm)	Thickness of Concrete core (mm)	Thickness of the external shuttering leaf (mm)	Total thickness (mm)	Reduction of the thermal resistance of the wall $\frac{\Delta R}{R_{DI} + R_{DC}} * 100$ caused by the structure of the shuttering leaves and the influence of the ladders [%]
M 121	45	210	45	300	12
Jumbo M175, M20, M100, PM 100	45	160	45	250	12
Jumbo M175+1, M20+1, M100+1	45	160	95	300	8
Jumbo M175+2, M20+2, M100+2	45	160	145	350	6
Jumbo M175+3, M20+3, M100+3	45	160	195	400	4,5
Jumbo M175+4, M20+4, M100+4	45	160	245	450	4

3.6.2 Thermal inertia

The values for heat capacity of concrete and expanded polystyrene are tabulated in EN 12524.

3.7 Sustainable use of natural resources (BWR 7)

For the sustainable use of natural resources no performance was investigated for this product.

³ EN ISO 6946:1996 Building components and building elements - Thermal resistance and thermal transmittance - Calculation method

English translation prepared by DIBt

3.8 General aspects

3.8.1 Resistance to deterioration

Physical agent

As given in the designation code of the EPS material used (see Annex A1 to A3) the dimensions of the shuttering leaves do not differ more than 3 % after exposing them for 48 h at 70 °C (DS(70,-)3).

The requirements according to ETAG 009, chapter 6.7.1.1 are met satisfactory.

Chemical agent

During construction the plastic capsule according to Annex A3 are to protect the cutting edges of the flat steels from corrosion. The ladders made of steel are only necessary for the resistance to concrete pressure. After hardening of the concrete the bond between concrete and shuttering leaves is given by the dovetail sections running vertically on the inner surfaces of shuttering leaves (see 3.4.1).

Therefore the requirement "corrosion protection" according to ETAG 009, chapter 6.7.1.2 is met satisfactory.

Biological agent

The application of EPS as thermal insulating material for decades has shown that it sufficiently protects against fungi, bacteria, algae and insects.

EPS does not provide a food value and in general it does not contain voids suitable for habitation by vermin.

The requirements according to ETAG 009, chapter 6.7.1.3 are met satisfactory.

3.8.2 Resistance to normal use damage

Incorporation of ducts

The instructions in the installation guide of the ETA applicant are appropriate to produce horizontal perforations through the walls, which are necessary for the passing through ducts.

Fixing of objects

Fixing of objects in the shuttering leaves is not possible; the part of fixings which is significant for the mechanical resistance shall be in the concrete core.

The verification of durability is part of testing the essential characteristics. Durability is only ensured if the specifications of intended use according to Annex (B) are taken into account.

4 Assessment and verification of constancy of performance (AVCP) system applied, with reference to its legal base

According to Decision of the Commission of 05. December 1997 (98/279/EG) (OJ L 127 of 24.04.1998, p. 26-28), as amended by Decision of the Commission of 08 January 2001 (2001/596/EG) (OJ L 209 of 02.08.2001, p. 33-42), the system of assessment and verification of constancy of performance (see Annex V and Article 65 Paragraph 2 to Regulation (EU) No 305/2011) given in the following table applies.

Product	Intended use(s)	Level or class	System
<p>Non load-bearing permanent shuttering kit/systems, to be filled with normal concrete and where relevant, with reinforcement, based on:</p> <ul style="list-style-type: none"> -hollow blocks made of an insulating material (or a combination of an insulating material and other materials) -panels made of an insulating material (or a combination of an insulating material and other materials), consisting of shuttering leaves linked by spacers. 	<p>For the construction of external and internal walls subject to fire regulations, in buildings</p> <p>For the construction of external and internal walls not subject to fire regulations, in buildings</p>	any	2+

5 Technical details necessary for the implementation of the AVCP system, as provided for in the applicable EAD

Technical details necessary for the implementation of the AVCP system are laid down in the control plan deposited at Deutsches Institut für Bautechnik.

Issued in Berlin on 30 April 2015 by Deutsches Institut für Bautechnik

Andreas Kummerow
p. p. Head of Department

beglaubigt:
Hutfilz

The shuttering elements correspond to the information and drawings given in the Annexes A1 to A4. The characteristic data of the standard and special shuttering elements are given in the Tables of Annexes A1 and A2. The kit consists of the following shuttering elements:

- standard shuttering elements (Annex A1)
- end shuttering elements (Annex A2)
- corner shuttering elements (Annex A2)

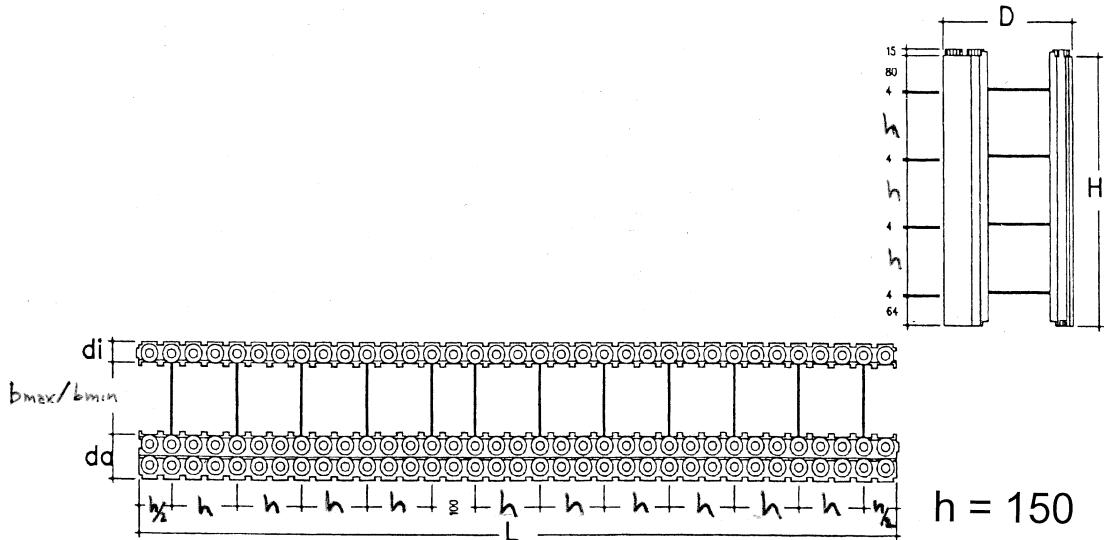

Type	L	H	D	d _a	b _{max}	b _{min}	d _i
JUMBO M175	1750	600	250	45	160	145	45
JUMBO M175+1	1750	600	300	95	160	145	45
JUMBO M175+2	1750	600	350	145	160	145	45
JUMBO M175+3	1750	600	400	195	160	145	45
JUMBO M175+3	1750	600	450	245	160	145	45
M20	1750	200	250	45	160	145	45
M20+1	1750	200	300	95	160	145	45
M20+2	1750	200	350	145	160	145	45
M20+3	1750	200	400	195	160	145	45
M20+4	1750	200	450	245	160	145	45
M100	1000	300	250	45	160	145	45
M100+1	1000	300	300	95	160	145	45
M100+2	1000	300	350	145	160	145	45
M100+3	1000	300	400	195	160	145	45
M100+4	1000	300	450	245	160	145	45
M121	1000	300	300	45	210	195	45
PM100	1000	300	250	45	160	145	45

All dimensions in mm.

For the shuttering leaves expanded polystyrene EPS-EN 13163-T1-L1-W2-S2-P4-DS(70,-)3-BS200-CS(10)150-DS(N)5-TR100 made of polystyrene particle foam with a apparent density of 27,5 bis 32 kg/m³ respectively a thermal conductivity $\lambda_d = 0,0329$ W/(m·K) according to EN 13163 is used.

Euromac 2

Normal (standard) shuttering elements

Annex A1

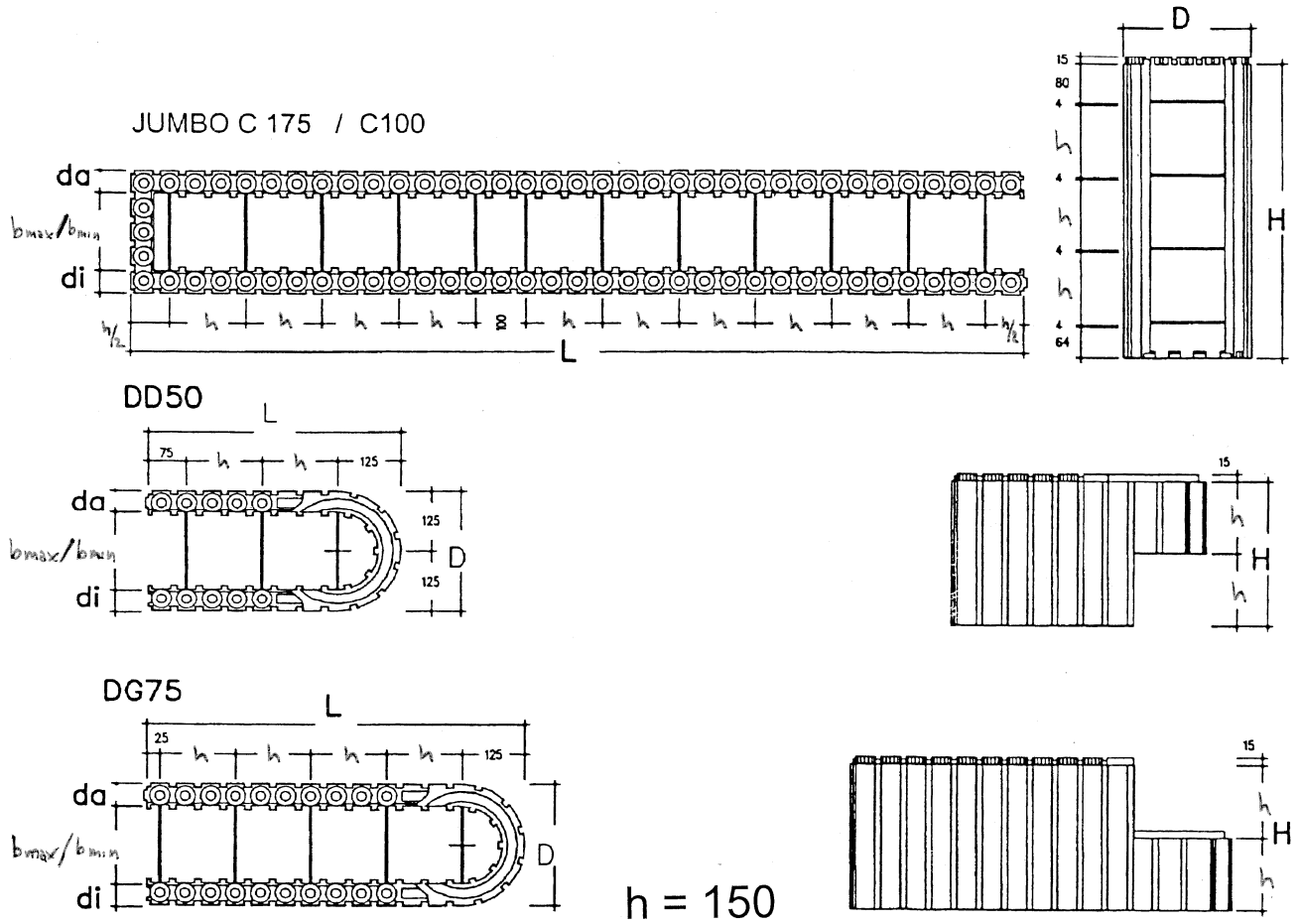

Type	L	H	D	d _a	b _{max}	b _{min}	d _i
JUMBO C175	1750	600	250	45	160	145	45
DD50	500	300	250	45	160	145	45
DG75	750	300	250	45	160	145	45
C100	1000	300	250	45	160	145	45

electronic copy of the eta by dibt: eta-05/0001

Euromac 2

Special shuttering elements

Annex A2

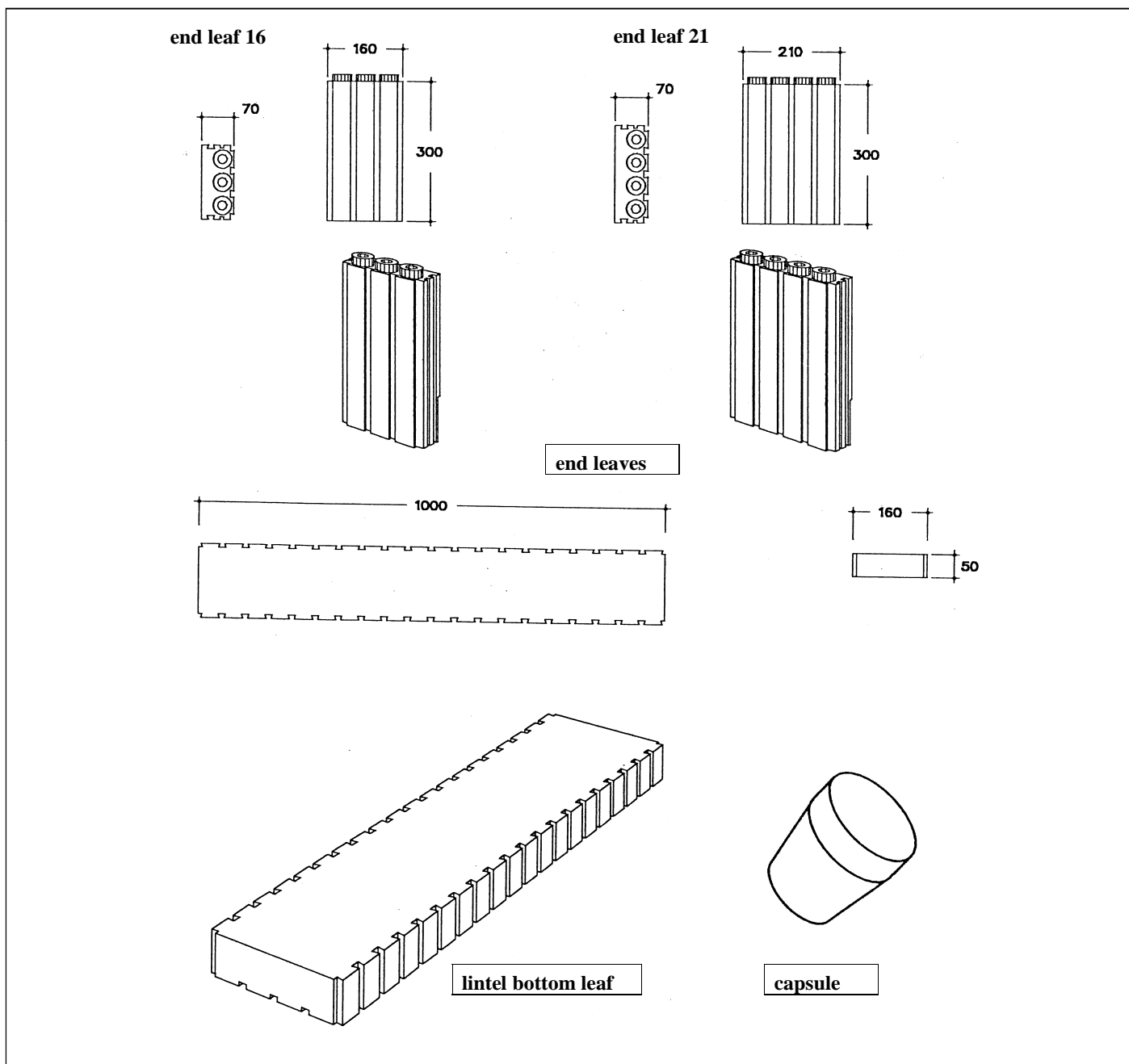

- End leaves are made of the same form and EPS material as the shuttering leaves with a thickness of 70 mm. There are two length of end leaves in dependence of the thickness of concrete core, 160 mm and 210 mm. The vertical mating surfaces are tongue and groove.
- Lintel bottom leaves are made of the same EPS material as the shuttering leaves with a thickness of 50 mm. There are only lintel bottom leaves for the shuttering elements with a maximum thickness of concrete core (see b_{max} in Annex A1) of 160 mm. Their width is 160 mm and their length 1 m (see Annex A3). Their vertical surfaces in length direction are shaped in such a way that a form fit to the inner surfaces of the shuttering leaves is possible.
- The capsule according to Annex A4 are made of plastic. They protect the cutting edges of the flat steels against corrosion and personal injury during construction.

Euromac 2

Accessory parts (end elements, lintel elements, capsule)

Annex A3

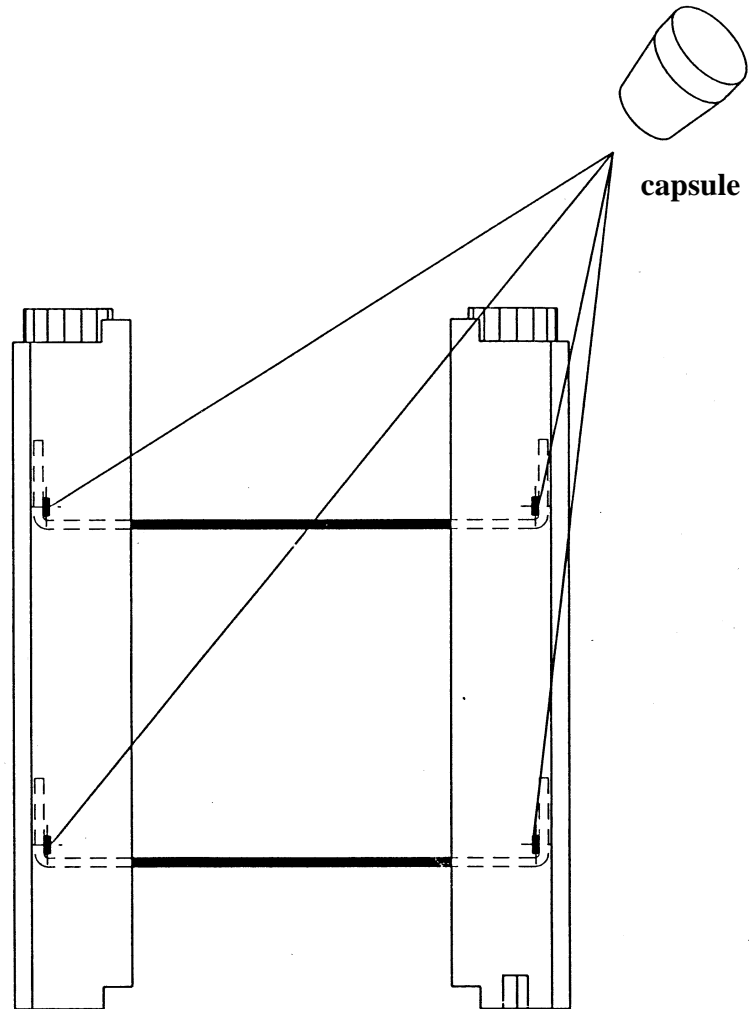

Plastic capsule to cover the flat steels of the ladders on cutting edges

electronic copy of the eta by dibt: eta-05/0001

Euromac 2

Plastic capsule

Annex A4

TYPE	In accordance with	wall thickness cm	average core thickness m	core area m ² /m	volume of core concrete m ³ /m ²	calculation weight of shuttering elements without rendering kN/m ²	weight of wall filled with concrete (assumed density of 2.500 kg/m ³) without rendering kN/m ²
JUMBO C 175	2	25	0.155	0.155	0.155	0.065	3.94
JUMBO M 175	1	25	0.155	0.155	0.155	0.065	3.94
JUMBO M 175+1	1	30	0.155	0.155	0.155	0.08	3.96
JUMBO M 175+2	1	35	0.155	0.155	0.155	0.095	3.97
JUMBO M 175+3	1	40	0.155	0.155	0.155	0.11	3.99
JUMBO M 175+4	1	45	0.155	0.155	0.155	0.125	4.00
JUMBO M 20	1	25	0.155	0.155	0.155	0.065	3.94
JUMBO M 20+1	1	30	0.155	0.155	0.155	0.08	3.96
JUMBO M 20+2	1	35	0.155	0.155	0.155	0.095	3.97
JUMBO M 20+3	1	40	0.155	0.155	0.155	0.11	3.99
JUMBO M 20+4	1	45	0.155	0.155	0.155	0.125	4.00
M100	1	25	0.155	0.155	0.155	0.065	3.94
M100+1	1	30	0.155	0.155	0.155	0.08	3.96
M100+2	1	35	0.155	0.155	0.155	0.095	3.97
M100+3	1	40	0.155	0.155	0.155	0.11	3.99
M100+4	1	45	0.155	0.155	0.155	0.125	4.00
C100	2	25	0.155	0.155	0.155	0.065	3.94
M121	1	30	0.205	0.205	0.205	0.065	3.94
PM100	1	25	0.155	0.155	0.155	0.065	3.94
DG75	2	25	0.155	0.155	0.155	0.065	3.94
DD50	2	25	0.155	0.155	0.155	0.065	3.94
DS50	2	25	0.155	0.155	0.155	0.065	3.94

Euromac 2

Dimensions and weights for the structural design

Annex A5

1.0 Installation

1.1 General

The manufacturer shall ensure that the requirements in accordance with sections 1, 2, and annex B are made known to those involved in planning and execution. The installation guide is deposited at DIBt and shall be present at every construction site. If the manufacturer's instructions contain provisions which differ from those stated here, the specifications of the ETA shall apply.

After installation of the shuttering elements (see 1.2) the site-mixed or ready mixed concrete is brought in and compacted.

In end use conditions concrete walls of continuous type¹ of plain or reinforced concrete according to EN 1992-1-1 or corresponding national rules will be formed.

For structural design dimensions and weights given in Annex A5 have to be used.

In end use conditions the EPS-shuttering leaves are the main part of the thermal insulation of the walls.

1.2 Installation of the shuttering elements

The shuttering elements are put together on site in layers joint mortar or adhesive. To receive stable floor high formworks the vertical joints between two elements of one layer have to be shifted of at least a quarter of the element length to the vertical joints of the previous and next layer (see Annex B3).

First of all two layers of the entire floor plan are to be interlocked according to the installation guide of the manufacturer.

Afterwards leveling to the subsoil is performed (foundation, bottom plate, ceiling). Voids between the shuttering leaves and the uneven subsoil are to be sealed with PU foam before concreting.

Subsequently, according to the installation guide of the manufacturer, the walls are to be interlocked to floor height, leveled and fastened to the scaffolding supports.

The scaffolding supports are to be arranged at a distance of 1.20 m to 1.50 m at the most, to be connected over the entire wall height with the shuttering elements and to be fastened to the floor. Cut sections of flat steels which are visible after cutting the elements at the door and window openings are to be covered with plastic capsule according to Annex A4.

The necessary reinforcement according to the structural analysis shall also be installed in an appropriate way. Rectangular wall corners are to be formed according to Annex B4, wall junctions according to Annex B5 and wall corners of arbitrary angle according Annex B6.

4.2.3 Concreting

For the production of normal concrete EN 206-1:2001-07 shall apply. The consistency of concrete on compacting by shaking shall be within the lower consistency range F3 and on compacting by poking within the upper consistency range F3. The maximum aggregate size shall be at least 8 mm and shall not exceed 16 mm. The concrete shall have rapid or middle strength development according to EN 206-1:2001-07, Table 12.

Placing the concrete shall be performed only by persons who were instructed in the works and in the proper handling of the shuttering system.

The maximum filling height amounts to 1 m at a concreting velocity of 3 m/h.

If equivalent national rules are not available the following instructions shall be considered:

Horizontal day joints are to be arranged preferably at the height of the floor. In the case these can not be avoided vertical composite reinforcement bars has to be installed. The composite reinforcement shall comply the following requirements:

¹ see ETAG 009 chapter 2.2

electronic copy of the eta by dibt: eta-05/0001

Euromac 2	Annex B1
Installation	

- two adjacent composite reinforcement bars shall not be situated in the same plane parallel to the surface of the wall,
- the distance between two composite reinforcement bars in wall direction shall be at least 10 cm and not larger than 50 cm,
- the total section area of the composite reinforcement bars shall not be minor than 1/2000 of the section area of the concrete,
- anchorage length of the composite reinforcement bars on both sides of the day joint at least shall be 20 cm

Before the further placing of concrete, cement laitance and detached / loose concrete shall be removed and the day joints shall be sufficiently pre-wetted. At the time of concreting the surface of the older concrete shall be slightly moist, so that the cement paste of the newly brought in concrete can combine well with the older concrete.

If no day joint is planned, placing of concrete in layers may only be interrupted if the concrete layer brought in last has not yet solidified so that a good and even bond is still possible between the two concrete layers. When using internal vibrators the vibrating cylinder shall still penetrate into the already compacted lower concrete layer.

The concrete may fall freely only up to a height of 2 m, beyond that the concrete shall be cohered by discharge pipes or concreting tubes with a diameter of 100 mm at the most and shall be led shortly before the place of installation.

Cones from pouring are to be avoided by short distances of the places of fill in.

Planning shall allow for sufficient spaces in the reinforcement for discharge pipes or concreting tubes.

After concreting the walls may not deviate from the plumb line more than 5 mm per running meter wall height.

The ceiling may only be placed on walls made of shuttering elements if a sufficient strength of the concrete core exists.

4.2.4 Ducts crossing and situated inside the wall

Horizontally passing ducts are to be installed according to the installation guide of the ETA applicant and are to be taken into account when designing the wall.

Horizontal ducts situated inside the wall cores are to be avoided. If absolutely necessary, these are to be taken into account when designing the wall.

Also vertical ducts in the concrete core shall be considered, if their diameter exceeds 1/6 of the thickness of the concrete core and the distance of the pipes is less than 2 m.

4.2.5 Reworking and finishes

Walls of the type "EUROMAC 2" are to be protected by finishes. Finishes are not part of the kit and therefore not considered in this ETA. Preferably for external surfaces the used rendering systems should meet the requirement of ETAG 004². The execution of the rendering shall be performed according to applicable national rules.

4.2.6 Fixing of objects

Fixing of objects in the shuttering leaves is not possible; the part of fixings which is significant for the mechanical resistance shall be in the concrete. The influence of the fixing to the reduction of the thermal resistance has to be considered according to EN ISO 6946.

² EOTA Guideline for External Thermal Insulation Composite Systems with rendering

Euromac 2	Annex B2
Installation	

1st layer

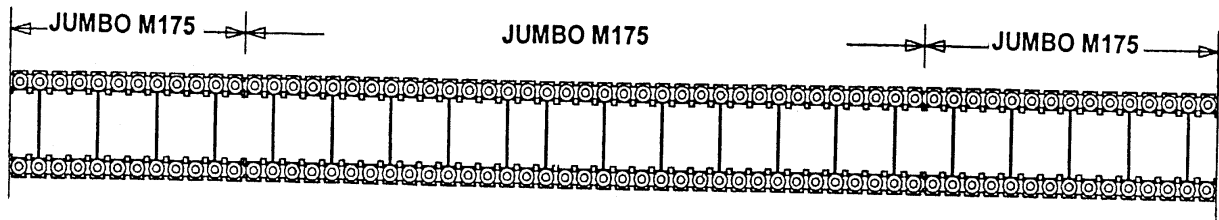

2nd layer

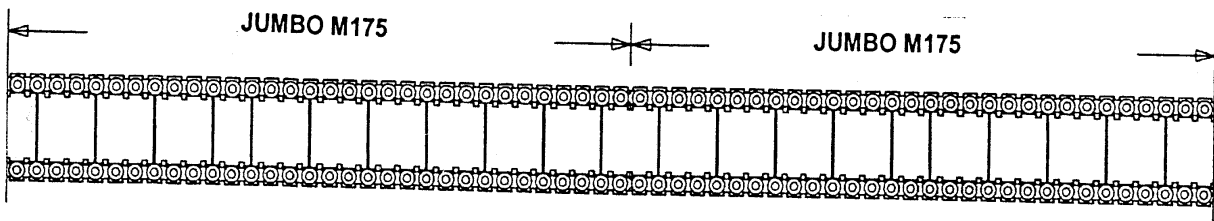

electronic copy of the eta by dibt: eta-05/0001

Euromac 2

Structure of layer on a straight wall

Annex B3

1st layer

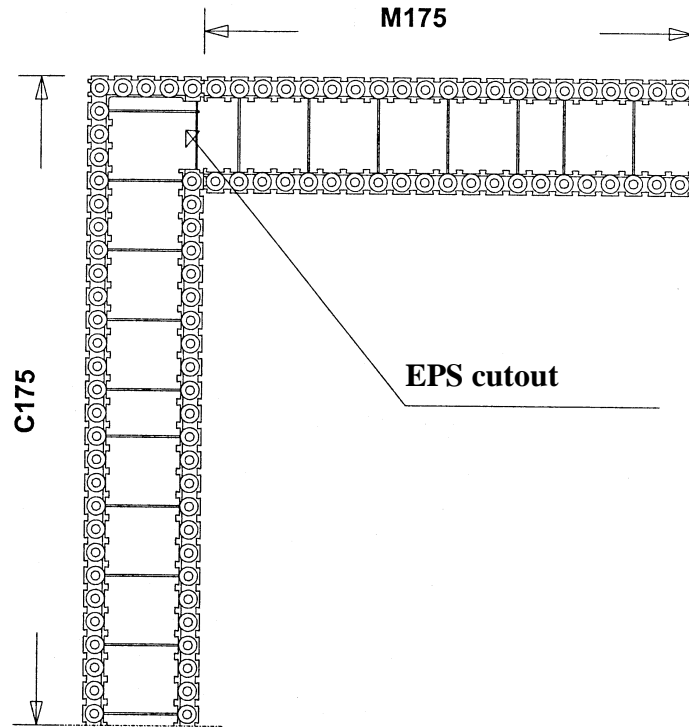

2nd layer

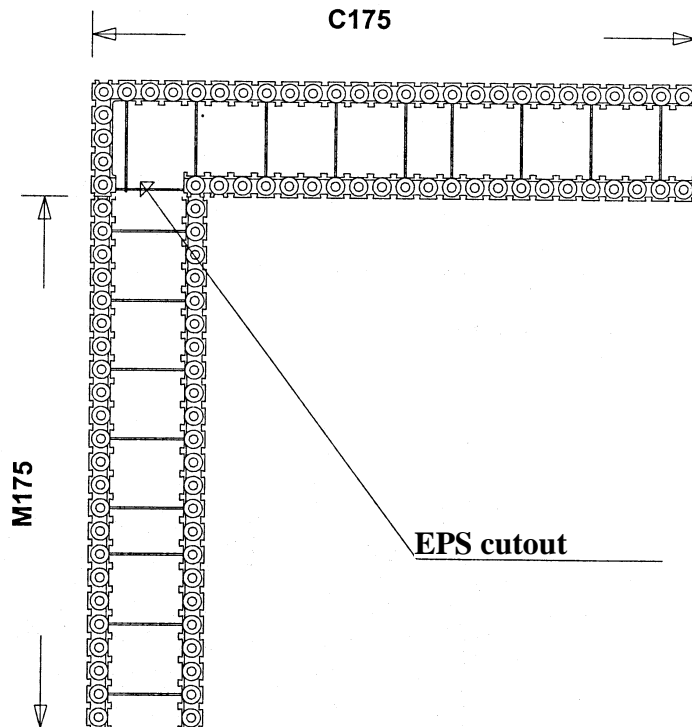

Euromac 2

Structure of layer on a rectangular wall corner

Annex B4

1st layer

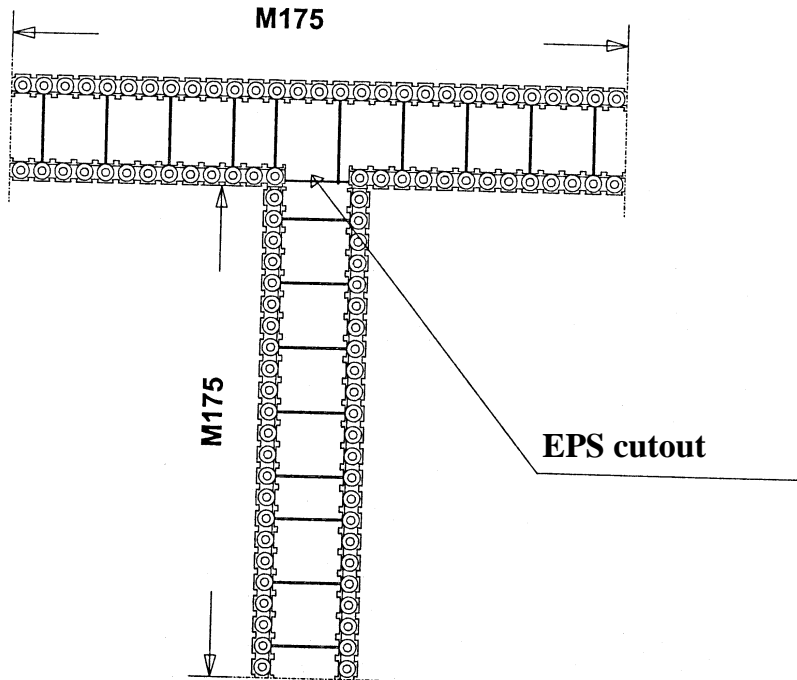

2nd layer

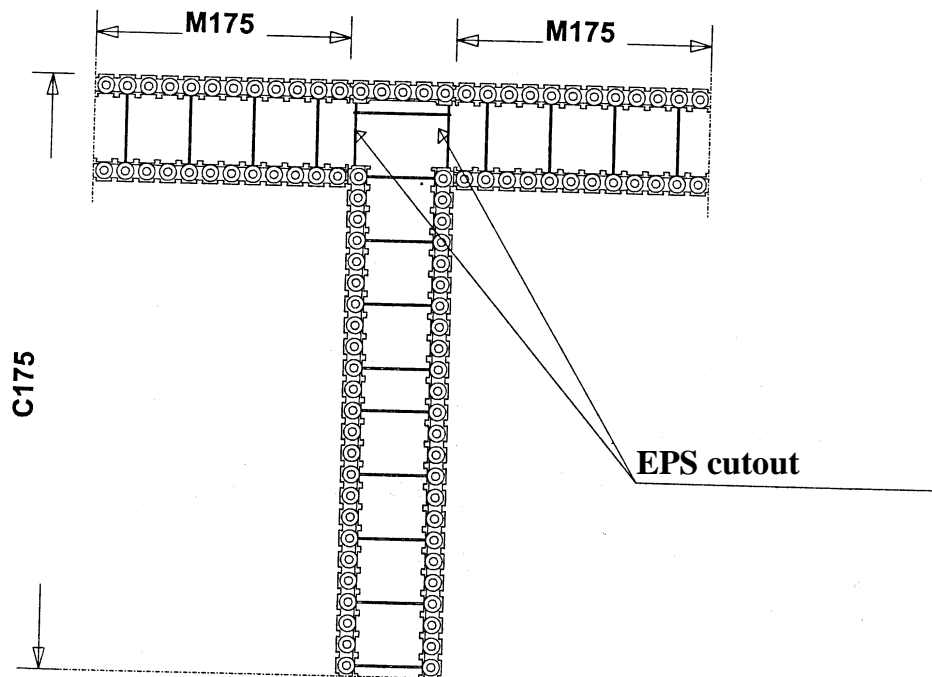

electronic copy of the eta by dibt: eta-05/0001

Euromac 2

Structure of a layer at wall junctions

Annex B5

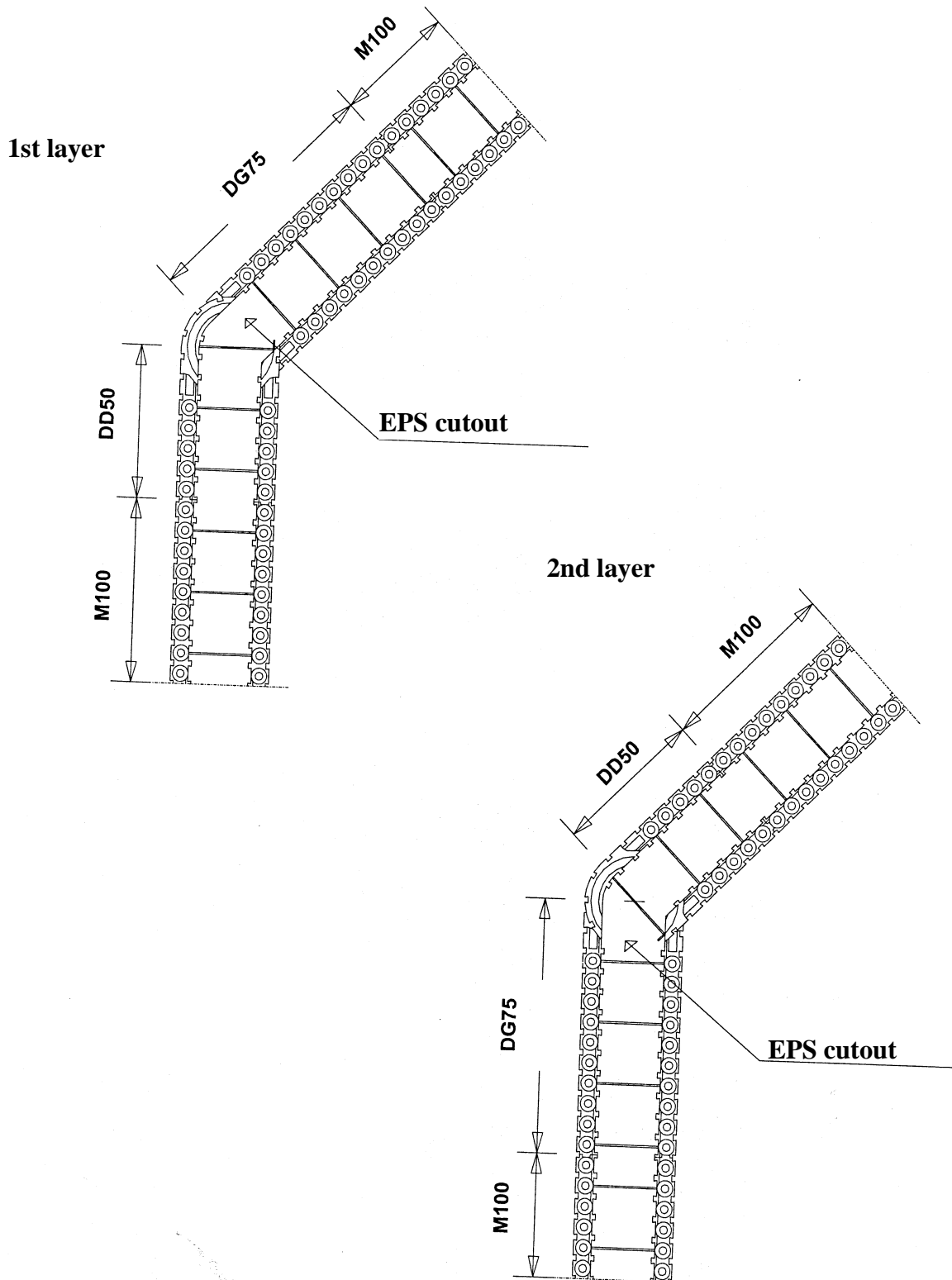

electronic copy of the eta by dibt: eta-05/0001

Euromac 2

Structure of layer at wall corners of arbitrary angle

Annex B6