

Approval body for construction products
and types of construction

Bautechnisches Prüfamt

An institution established by the Federal and
Laender Governments



European Technical Assessment

ETA-05/0202
of 18 December 2015

English translation prepared by DIBt - Original version in German language

General Part

Technical Assessment Body issuing the
European Technical Assessment:

Deutsches Institut für Bautechnik

Trade name of the construction product

BBV-Internal Bonded Strand Post-tensioning System,
type i

Product family
to which the construction product belongs

BBV-Internal Bonded Post-Tensioning System for 3 to 31
Strands (140 and 150 mm²)

Manufacturer

BBV Systems GmbH
Industriestraße 98
67240 Bobenheim-Roxheim
DEUTSCHLAND

Manufacturing plant

BBV Systems GmbH
Industriestraße 98
67240 Bobenheim-Roxheim
DEUTSCHLAND

This European Technical Assessment
contains

35 pages including 30 annexes which form an integral
part of this assessment

This European Technical Assessment is
issued in accordance with Regulation (EU)
No 305/2011, on the basis of

Guideline for European technical approval of "Post-
tensioning kits for prestressing of structures", ETAG 013,
used as European Assessment Document (EAD)
according to Article 66 Paragraph 3 of Regulation (EU)
No 305/2011.

The European Technical Assessment is issued by the Technical Assessment Body in its official language. Translations of this European Technical Assessment in other languages shall fully correspond to the original issued document and shall be identified as such.

Communication of this European Technical Assessment, including transmission by electronic means, shall be in full. However, partial reproduction may only be made with the written consent of the issuing Technical Assessment Body. Any partial reproduction shall be identified as such.

This European Technical Assessment may be withdrawn by the issuing Technical Assessment Body, in particular pursuant to information by the Commission in accordance with Article 25(3) of Regulation (EU) No 305/2011.

Specific Part

1 Technical description of the product

1.1 Definition of the construction product

The present European Technical Approval applies to a kit:

BBV-Internal Bonded Strand Post-Tensioning System, type i

consisting of 3 to 31 strands with a nominal tensile strength 1770 N/mm² or 1860 N/mm² (Y1770 S7 or Y1860 S7) in accordance with prEN 10138-3, table 4, nominal diameter 15.3 mm (0.6" - 140 mm²) or 15.7 mm (0.62" - 150 mm²) which are used in normal-weight concrete with the following anchors (stressing and fixed anchors and couplers):

1. Stressing (active) anchor type S and fixed (passive) anchor type F and Fe with bearing plate and anchor head for tendons of 3, 4, 5, 7 and 9 strands,
2. Stressing (active) anchor type S and fixed (passive) anchor type F and Fe with cast iron anchor body and anchor head for tendons of 12, 15, 19, 22, 27 and 31 strands,
3. Coupler ÜK (fixed (FÜK) and movable (BÜK)) for tendons of 3, 4, 5, 7, 9, 12, 15, 19, 22, 27 and 31 strands,

Additional components of the present Post-tensioning system are:

1. Bursting reinforcement (helixes and stirrups),
2. Sheathing (ducts),
3. Corrosion protection.

The anchorage of the strands in anchor heads and couplers is done by means of wedges.

The components and the system setup of the product are given in Annex A.

1.2 Strands

Only 7-wire strands shall be used in accordance with nationally provisions with the characteristics given in Table 1:

Table 1: Dimensions and properties of 7-wire strands

Designation	Symbol	Unit	Value	
Tensile strength	R_m	MPa	1770 or 1860	
Strand				
Nominal diameter	D	mm	15.3	15.7
Nominal cross section	A_p	mm ²	140	150
Nominal mass	M	g/m	1093	1172
Individual wires				
External wire diameter	d	mm	5.0 ± 0.04	5.2 ± 0.04
Core wire diameter	d'	mm	1.02 to 1.04 d	1.02 to 1.04 d

To avoid confusions only strands with one nominal diameter shall be used on one site. If the use of the strands with $R_m = 1860$ MPa is intended on site, these shall solely be used there.

Only strands stranded in the same direction shall be used in a tendon. Further characteristic values of the strands see Annex B.

1.3 Wedges

Wedges type 30, smooth or knurled, (see Annex A3) shall be used. The knurled wedges shall only be used for pre-wedged (pre-locked) ones at fixed anchors. The segments of the wedges for strands \varnothing 15.7 mm shall be marked with "0.62".

English translation prepared by DIBt

1.4 Anchor heads and couplers

The conical drills of the anchor heads and couplers shall be clean and stainless and provided with a corrosion protection grease.

1.5 Bearing plates

For 3 to 9 strands rectangular bearing plates shall be used. The long side of the bearing plates shall be installed parallel to the biggest centre or edge distance (see Annex A2 page 1/4 and 3/4 and Annex A4).

1.6 Cast-iron anchor bodies

For 12 to 31 strands multi-surfaced cast-iron anchor bodies shall be used (see Annex A4).

1.7 Helixes and stirrups

The steel grades and dimensions of the helixes and of the stirrups shall comply with the values given in the Annexes. The central position in the structural concrete member on site shall be ensured according to Annex B, section 3.1.3.

1.8 Ducts

Ducts shall be used according to EN 523:2003. For tendons BBV L3 and BBV L4 use may also be made of oval ducts. For these ducts EN 523:2003 applies accordingly. The dimensions of the ducts shall comply with the values given in Annex A2. The trumpets at stressing and fixed anchors (see Annexes A3, A4) are manufactured from 3.5 mm thick PE material (BBV L12 to L31). The other trumpets (see Annexes A3, A4 and A6) are manufactured from steel. In the area of possible contact between strands and steel trumpet (point of deviation) PE pipes of at least 4 mm thickness and a length of 120.0 mm shall be provided for avoiding any contact between strands and steel. The PE pipes shall be fixed in the right position. When using trumpets made of plastic with a minimum thickness of 3.5 mm, it is not necessary to install a PE pipe. It shall be made sure that at anchors and couplers for 3 to 22 and 31 strands (1.part, Annex A6) the maximum deflection angle of the strand is 2.6° (at the end of the wedge and at the deviation point between trumpet and duct). For 27 strands the maximum deflection angle is 2.1°. The deflection at couplers (2.part, Annex A6) is 7° (at the deviation point between trumpet and duct). At the end of the wedge normally there is no deflection.

Also plastic ducts which meet the requirements according to ETAG 013, Annex C.3 and in accordance with regulations valid at the place of use can be used. Plastic ducts or the accompanying boundary conditions are not covered by ETA-05/0202.

1.9 Grout

Grout shall be used according to EN 447:2008.

2 Specification of the intended use in accordance with the applicable European assessment Document

The performances given in Section 3 are only valid if the PT-System is used in compliance with the specifications and conditions given in Annex B.

The verifications and assessment methods on which this European Technical Assessment is based lead to the assumption of a working life of the PT-System of at least 100 years. The indications given on the working life cannot be interpreted as a guarantee given by the producer, but are to be regarded only as a means for choosing the right products in relation to the expected economically reasonable working life of the works.

3 Performance of the product and references to the methods used for its assessment

3.1 Mechanical resistance and stability (BWR 1)

Essential characteristic	Performance
Resistance to static load	The PT system as described in the ETA meets the acceptance criteria of ETAG 013, Clause 6.1.1-I
Resistance to fatigue	The PT system as described in the ETA meets the acceptance criteria of ETAG 013, Clause 6.1.2-I
Load Transfer to structure	The PT system as described in the ETA meets the acceptance criteria of ETAG 013, Clause 6.1.3-I
Friction coefficient	The PT system as described in the ETA meets the acceptance criteria of ETAG 013, Clause 6.1.4-I See Annex C 1
Deviation/deflection (limits)	The PT system as described in the ETA meets the acceptance criteria of ETAG 013, Clause 6.1.5-I

4 Assessment and verification of constancy of performance (AVCP) system applied, with reference to its legal base

In accordance with guideline for European technical approval ETAG 013, June 2002, used as European Assessment Document (EAD) according to Article 66 Paragraph 3 of Regulation (EU) No 305/2011, the applicable European legal act is: [98/456/EC].

The system to be applied is: 1+

5 Technical details necessary for the implementation of the AVCP system, as provided for in the applicable EAD

Technical details necessary for the implementation of the AVCP system are laid down in the control plan deposited at Deutsches Institut für Bautechnik.

Issued in Berlin on 18 December 2015 by Deutsches Institut für Bautechnik

Uwe Bender
Head of Department

beglaubigt:
Sultani

OVERVIEW ANCHORAGES

1. Active Anchor (S) and Passive Anchor (F) BBV L3 – BBV L9

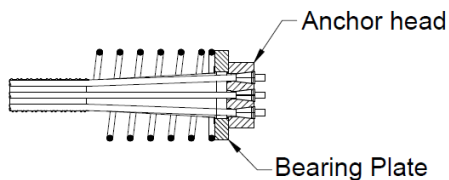

2. Active Anchor (S) and Passive Anchor (F) BBV L12 – BBV L31

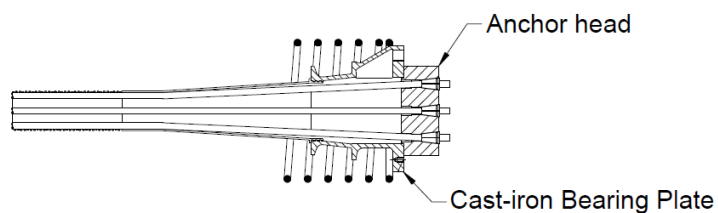

3. Embedded Passive Anchor (Fe) BBV L3 – BBV L9

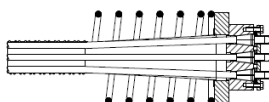

4. Embedded Passive Anchor (Fe) BBV L12 – BBV L31

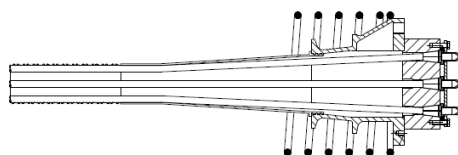

5. Coupler (ÜK) BBV L3 – BBV L9

Fixed Coupler (FÜK)

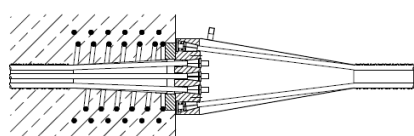

Movable Coupler (BÜK)

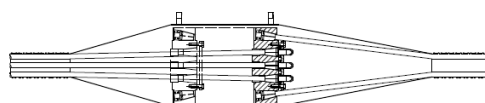

6. Coupler (ÜK) BBV L12 – BBV L31

Fixed Coupler (FÜK)

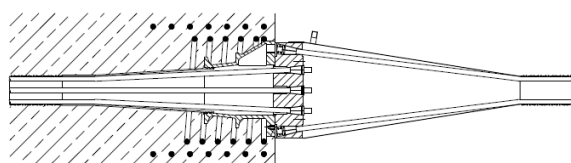

Movable Coupler (BÜK)

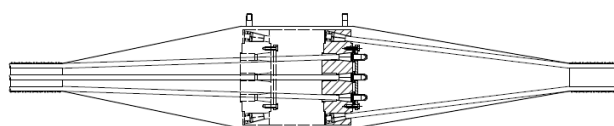

BBV-Internal Bonded Strand Post-tensioning System, type i

Description of the product
Overview Anchorages

Annex A1

TECHNICAL DETAILS BBV L 3 – BBV L 9
Steel Grade Y1770
Anchors (S), (F), (Fe), Coupler (FÜK),(BÜK)

Tendon Type		BBV L 3	BBV L 4	BBV L 5	BBV L 7	BBV L 9
Strand Pattern						
Number of strands	n	3	4	5	7	9
150mm² : Nominal Cross Section A_p	mm ²	450	600	750	1050	1350
150mm² : Nominal mass M	kg/m	3.52	4.69	5.86	8.20	10.55
150mm² : Ultimate Force F_{pk}	kN	797	1062	1328	1859	2390
150mm² : P_{max} = 0.90 · f_{p0.1k} · A_p ***	kN	616	821	1026	1436	1847
150mm² : P_{m0(X)} = 0.85 · f_{p0.1k} · A_p ***	kN	581	775	969	1357	1744
140mm² : Nominal Cross Section A_p	mm ²	420	560	700	980	1260
140mm² : Nominal mass M	kg/m	3.28	4.37	5.47	7.65	9.84
140mm² : Ultimate Force F_{pk}	kN	743	991	1239	1735	2230
140mm² : P_{max} = 0.90 · f_{p0.1k} · A_p ***	kN	575	766	958	1341	1724
140mm² : P_{m0(X)} = 0.85 · f_{p0.1k} · A_p ***	kN	543	724	904	1266	1628
Wobble Coefficient k	°/m	0.4	0.3	0.3	0.3	0.3
at max. Support Distance	m	1.80	1.80	1.80	1.80	1.80
Friction Coefficient μ	-	0.21	0.20 / 0.19 / 0.19	0.20 / 0.19 / 0.20	0.20 / 0.20 / 0.19	0.20 / 0.20 / 0.19
Friction Losses						
Active Anchor Δ P _{us}	%	1.2	1.2	1.2	1.1	1.0
Coupling Δ P _{uÜK}	%	1.2	1.2	1.2	1.1	1.2
Ducts						
Inner Diameter	mm	40****	45/50/55****	50/55/60	55/60/65	65/70/75
Outer Diameter	mm	46	51/56/62	56/61/67	61/67/72	72/77/82
Eccentricity, 150mm²	mm	5.4	6.3/9.7/12.6	7.5/10.7/13.8	5.7/9.0/12.1	8.4/12.1/15.4
Eccentricity, 140mm²	mm	6.1	6.9/10.1/13.1	8.8/11.9/15.0	7.2/10.4/14.2	10.5/13.9/17.1
Strand Protrusion **	cm	21,5	21,5	70	71	82
Anchors (S), (F), (Fe), Couplers (FÜK), (BÜK)						
Min. Centre Distance *****						
f _{cmj,cube} = 30 N/mm ²	mm	215 x 190	245 x 220	275 x 245	325 x 285	370 x 325
f _{cmj,cube} = 34 N/mm ²	mm	200 x 175	230 x 205	260 x 230	305 x 270	345 x 305
f _{cmj,cube} = 40 N/mm ²	mm	185 x 160	215 x 185	235 x 210	280 x 245	320 x 275
f _{cmj,cube} = 45 N/mm ²	mm	170 x 150	200 x 175	225 x 195	260 x 230	295 x 265

* Concrete cover shall be taken into account additionally (see Annex B1 page 3/4). Distances can be reduced to 85 % of the given values in one direction, if increased correspondingly in the other direction

** Distance from anchor head for placing of jack

*** Based on f_{p0.1k} ≈ 1520 N/mm² (Grade Y1770)

**** Oval ducts allowed to use for:
(inner dimensions)

BBV L 3 – (60 x 21mm)
BBV L 4 – (80 x 21mm)

Wobble coefficient k to be considered for oval ducts is: k = 0.8 °/m

Friction coefficient μ to be considered is:

Bending round the stiff axis:

Bending round the weak axis:

BBV L 3

μ = 0.23

μ = 0.15

BBV L 4

μ = 0.26

μ = 0.15

***** Min. edge distance : min. centre distance/2+20 mm (rounding up at 5 mm intervals). Concrete cover shall be taken into account additionally (see Annex B1 page 3/4).

BBV-Internal Bonded Strand Post-tensioning System, type i

Description of the product
Technical Details BBV L3 – BBV L9, Steel Grade Y 1770

Annex A2
Page 1/4

TECHNICAL DETAILS BBV L 12 – BBV L 31
Grade Y1770
Anchors (S), (F), (Fe), Couplers, (FÜK), (BÜK)

Tendon type		BBV L 12	BBV L 15	BBV L 19	BBV L 22	BBV L 27	BBV L 31
Strand Pattern							
Number of strands	n	12	15	19	22	27	31
150mm² : Nominal Cross Section A_p	mm ²	1800	2250	2850	3300	4050	4650
150mm² : Nominal Mass M	kg/m	14.06	17.58	22.27	25.78	31.64	36.58
150mm² : Ultimate Force F_{pk}	kN	3186	3983	5045	5841	7169	8231
150mm² : P_{max} = 0.90 · f_{p0.1k} · A_p ***	kN	2462	3078	3899	4514	5540	6361
150mm² : P_{m0(X)} = 0.85 · f_{p0.1k} · A_p ***	kN	2326	2907	3682	4264	5233	6008
140mm² : Nominal Cross Section A_p	mm ²	1680	2100	2660	3080	3780	4340
140mm² : Nominal Mass M	kg/m	13,12	16,40	20,77	24,05	29,51	34,07
140mm² : Ultimate Force F_{pk}	kN	2974	3717	4708	5452	6691	7682
140mm² : P_{max} = 0.90 · f_{p0.1k} · A_p ***	kN	2298	2873	3639	4213	5171	5937
140mm² : P_{m0(X)} = 0.85 · f_{p0.1k} · A_p ***	kN	2171	2713	3437	3979	4884	5607
Wobble Coefficient k	°/m	0.3	0.3	0.3	0.3	0.3	0.3
at max. Support Distance	m	1.80	1.80	1.80	1.80	1.80	1.80
Friction Coefficient μ	-	0.19 / 0.19/0,19	0,20/0.20 / 0.19	0.21 / 0.20	0.20 / 0.19	0.20 / 0.20	0.20 / 0.20
Friction Losses							
Active Anchor Δ P _{μs}	%	0.8	0.8	0.8	0.6	0.8	0.8
Coupler Δ P _{μÜK}	%	1.2	1.1	1.0	1.2	1.2	1.2
Ducts							
Inner Diameter	mm	75/80/90	80/85/90	90/95	100/110	110/115	115/125
Outer Diameter	mm	82/87/97	87/92/97	97/102	107/117	117/125	125/135
Eccentricity, 150mm²	mm	10.3/13.9/20.2	9.0/12.4/15.8	9.9/13.1	13.3/20.1	14.1/17.3	12.1/19.6
140mm²	mm	11.7/14.9/21.1	10.1/14.0/17.7	10.2/15.8	15.9/22.1	15.7/19.0	14.2/21.5
Strand Protrusion **	cm	80	80	110	110	120	120

Anchors (S), (F), (Fe), Couplers (FÜK), (BÜK)

Min. Centre / Edge Distance *		BBV L 12	BBV L 15	BBV L 19	BBV L 22	BBV L 27	BBV L 31
f _{cmj,cube} = 28 N/mm ²	mm	405/225	450/245	505/275	545/295	605/325	645/345
f _{cmj,cube} = 34 N/mm ²	mm	370/205	415/230	465/255	500/270	550/295	595/320
f _{cmj,cube} = 40 N/mm ²	mm	340/190	380/210	430/235	460/250	510/275	545/295
f _{cmj,cube} = 45 N/mm ²	mm	325/185	360/200	405/225	435/240	485/265	520/280

* and ** see Annex A2 page 1/4

*** based on f_{p0.1k} = 1520 N/mm² (Grade Y1770)

Strand Pattern BBV L 12; 19; 22; 27; 31

Conical borings are in line,
lines result in a grid

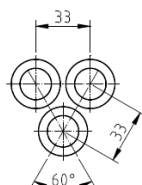

BBV L 3; 4; 5; 7; 9; 15

All conical borings are aligned on one or two circles
(e1 and e2).

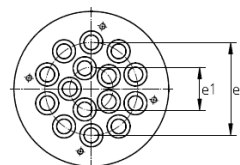





Example: BBV L15

BBV-Internal Bonded Strand Post-tensioning System, type i

Description of the product
Technical Details BBV L12 – BBV L31, Steel Grade Y 1770

Annex A2
Page 2/4

TECHNICAL DETAILS BBV L 3 – BBV L 9
Steel Grade Y1860
Anchors (S), (F), (Fe), Couplers (FÜK), (BÜK)

Tendon Type	Unit	BBV L 3	BBV L 4	BBV L 5	BBV L 7	BBV L 9
Strand Pattern						
Number of Strands	n	3	4	5	7	9
150mm² : Nominal Cross Section A _p	mm ²	450	600	750	1050	1350
150mm² : Nominal Mass M	kg/m	3.52	4.69	5.86	8.20	10.55
150mm² : Ultimate Force F _{pk}	kN	837	1116	1395	1953	2511
150mm² : P₀ = 0.90 · f_{p0.1k} · A_p ***	kN	648	864	1080	1512	1944
150mm² : P_{m0} = 0.85 · f_{p0.1k} · A_p ***	kN	612	816	1020	1428	1836
140mm² : Nominal Cross Section A _p	mm ²	420	560	700	980	1260
140mm² : Nominal Mass M	kg/m	3.28	4.37	5.47	7.65	9.84
140mm² : Ultimate Force F _{pk}	kN	781	1042	1302	1823	2344
140mm² : P₀ = 0.90 · f_{p0.1k} · A_p ***	kN	605	806	1008	1411	1814
140mm² : P_{m0} = .85 · f_{p0.1k} · A_p ***	kN	571	762	952	1333	1714
Wobble Coefficient k	°/m	0.4	0.3	0.3	0.3	0.3
at max. Support Distance	m	1.80	1.80	1.80	1.80	1.80
Friction Coefficient μ	-	0.21	0.20 / 0.19 / 0.19	0.20 / 0.19 / 0.20	0.20 / 0.20 / 0.19	0.20 / 0.20 / 0.19
Friction Losses						
Active Anchor Δ P _{μS}	%	1.2	1.2	1.2	1.1	1.0
Coupler Δ P _{μÜK}	%	1.2	1.2	1.2	1.1	1.2
Ducts		****	****			
Inner Diameter	mm	40	45/50/55	50/55/60	55/60/65	65/70/75
Outer Diameter	mm	46	51/56/61	51/61/67	61/67/72	72/77/82
Eccentricity, 150mm²	mm	5.4	6.3/9.7/12.6	7.5/10.7/13.8	5.7/9.0/12.1	8.4/12.1/15.4
140mm²	mm	6.1	6.9/10.1/13.1	8.8/11.9/15.0	7.2/10.4/14.2	10.5/13.9/17.1
Strand Protrusion **	cm	21,5	21,5	70	71	82
Anchors (S), (F), (Fe), Couplers (FÜK),(BÜK)						
Min. Centre Distance * *****						
f _{cmj,cube} = 30 N/mm ²	mm	215 x 190	245 x 220	275 x 245	325 x 285	370 x 325
f _{cmj,cube} = 34 N/mm ²	mm	200 x 175	230 x 205	260 x 230	305 x 270	345 x 305
f _{cmj,cube} = 40 N/mm ²	mm	185 x 160	215 x 185	235 x 210	280 x 245	320 x 275
f _{cmj,cube} = 45 N/mm ²	mm	170 x 150	200 x 175	225 x 195	260 x 230	295 x 265

* Concrete cover shall be taken into account additionally (see annex B1 page 3/4). Distances can be reduced to 85 % of the given values in one direction, if increased correspondingly in the other direction

** Distance from anchor head for placing of jack

*** Based on f_{p0.1k} ≈ 1600 N/mm² (Grade Y1860)

**** Oval ducts allowed to use for:

(inner dimensions)

Wobble coefficient k to be considered for oval ducts is:

BBV L 3 – (60 x 21mm)

BBV L 4 – (80 x 21mm)

k = 0.8 °/m

Friction coefficient μ to be considered is:

BBV L 3

BBV L 4

Bending round the stiff axis:

μ = 0.23

μ = 0.26

Bending round the weak axis:

μ = 0.15

μ = 0.15

***** Min. edge distance : min. centre distance/2+20 mm (rounding up at 5 mm intervals). Concrete cover shall be taken into account additionally (see annex B1 page 3/4).

BBV-Internal Bonded Strand Post-tensioning System, type i

Description of the product

Technical Details BBV L3 – BBV L9, Steel Grade Y 1860

Annex A2
Page 3/4

TECHNICAL DETAILS BBV L 12 – BBV L 31
Steel Grade Y1860
Anchors (S), (F), (Fe), Couplers (FÜK), (BÜK)

Tendon Type		BBV L 12	BBV L 15	BBV L 19	BBV L 22	BBV L 27	BBV L 31
Strand Pattern							
Number of Strands	n	12	15	19	22	27	31
150mm² : Nominal Cross Section A_p	mm ²	1800	2250	2850	3300	4050	4650
150mm² : Nominal Mass M	kg/m	14.06	17.58	22.27	25.78	31.64	36.58
150mm² : Ultimate Force F_{pk}	kN	3348	4185	5301	6138	7533	8649
150mm² : P_{max} = 0.90 · f_{p0.1k} · A_p ***	kN	2592	3240	4104	4752	5832	6696
150mm² : P_{m0(X)} = 0.85 · f_{p0.1k} · A_p ***	kN	2448	3060	3876	4488	5508	6324
140mm² : Nominal Cross Section A_p	mm ²	1680	2100	2660	3080	3780	4340
140mm² : Nominal Mass M	kg/m	13.12	16.40	20.77	24.05	29.51	34.07
140mm² : Ultimate Force F_{pk}	kN	3125	3906	4948	5729	7031	8072
140mm² : P_{max} = 0.90 · f_{p0.1k} · A_p ***	kN	2419	3024	3830	4435	5443	6250
140mm² : P_{m0(X)} = 0.85 · f_{p0.1k} · A_p ***	kN	2285	2856	3618	4189	5141	5902
Wobble Coefficient k	°/m	0.3	0.3	0.3	0.3	0.3	0.3
at max. Support Distance	m	1.80	1.80	1.80	1.80	1.80	1.80
Friction Coefficient μ	-	0.19 / 0.19 / 0.19	0.20/0.20 / 0.19	0.21 / 0.20	0.20 / 0.19	0.20 / 0.20	0.20 / 0.20
Friction Losses							
Active Anchor Δ P _{μs}	%	0.8	0.8	0.8	0.6	0.8	0.8
Coupler Δ P _{μÜK}	%	1.2	1.1	1.0	1.2	1.2	1.2
Ducts							
Inner Diameter	mm	75/80	85/90	90/95	100/110	110/115	115/125
Outer Diameter	mm	82/87	92/97	97/102	107/117	117/125	122/135
Eccentricity, 150mm²	mm	10.3/13.9	12.4/15.8	9.9/13.1	13.3/20.1	14.1/17.3	12.1/19.6
140mm²	mm	11.7/14.9	14.0/17.7	10.2/15.8	15.9/22.1	15.7/19.0	14.2/21.5
Strand Protrusion **)	cm	93	93	125	125	141	141
Anchors (S), (F), (Fe), Couplers (FÜK), (BÜK)							
Min. Centre/Edge Distance*							
f _{cmj,cube} = 28 N/mm ²	mm	405/225	450/245	505/275	545/295	605/325	645/345
f _{cmj,cube} = 34 N/mm ²	mm	370/205	415 /230	465/255	500/270	550/295	595/320
f _{cmj,cube} = 40 N/mm ²	mm	340/190	380/210	430/235	460/250	510/275	545/295
f _{cmj,cube} = 45 N/mm ²	mm	325/185	360/200	405/225	435/240	485/265	520/280

* and ** see Annex 2

*** based on f_{p0.1k} = 1600 N/mm² (Grade Y1860)

Strand Pattern BBV L 12; 19; 22; 27; 31

Conical borings are in line,
lines result in a grid.

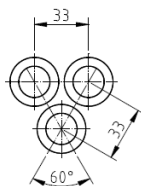

BBV L 3; 4; 5; 7; 9; 15

All conical borings are aligned on one or two circles
(e1 and e2).

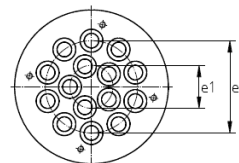

Example: BBV L15

BBV-Internal Bonded Strand Post-tensioning System, type i

Description of the product
Technical Details BBV L12 – BBV L31, Steel Grade Y 1860

Annex A2
Page 4/4

DESCRIPTION OF WEDGE ANCHORAGES

**Active Anchors (S)
Passive Anchors (F), (Fe)**

Active anchors (S) with bearing plate and anchor head
Accessible passive anchor (F) with bearing plate and anchor head

For embedded Passive Anchor (Fe) the anchor head is tack-welded to the bearing plate, the wedges are sealed and secured in their cones by a retainer plate. The area around the wedges of embedded passive anchors is to be filled with corrosion protection mass and filled sealing caps are to be applied.

L 3 – L 9

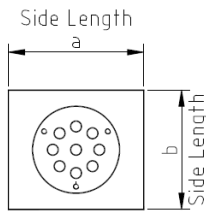

Shown BBV L 9

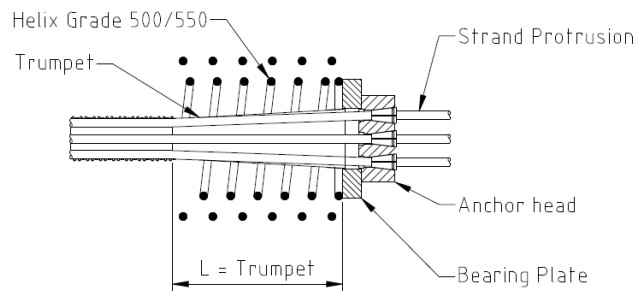

Tendon Type BBV L 3 – L9: active anchor and passive anchor with rectangular bearing plate $a \times b$ and anchor head.

L 12 – L 31

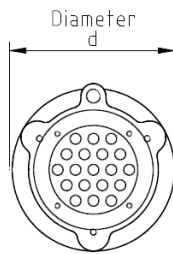

Shown BBV L 19

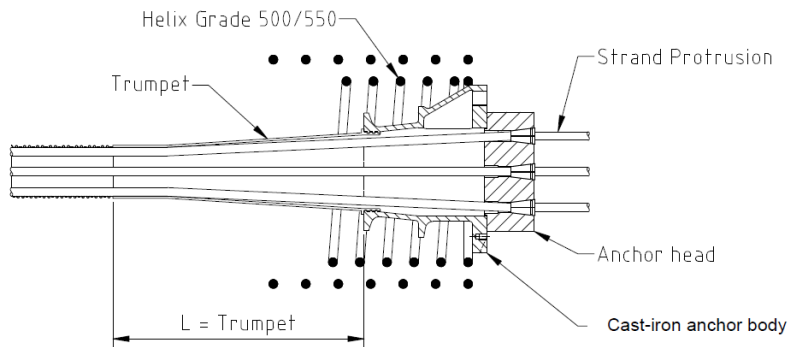

Tendon Type BBV L 12 – L 31: active anchor with cast-iron anchor body of diameter d and anchor head.

Wedges Type 30

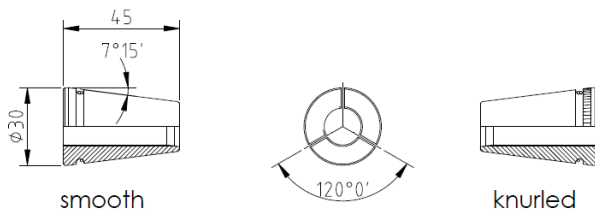

Optional knurled wedges for pre-wedged passive anchors

Wedges for 150 mm² strands are marked with "0.62" on the front face.

BBV-Internal Bonded Strand Post-tensioning System, type i

Description of the product
Wedge Anchorages

Annex A3

DIMENSIONS OF ANCHOR COMPONENTS

Tendon Type		L3	L4	L5	L7	L9	L12	L15	L19	L22	L27	L31
Bearing Plate												
Side length a	mm	160	180	195	215	250						
Side length b	mm	140	160	170	190	220						
Thickness	mm	25	25	30	35	35						
Hole diameter	mm	72	81	83	93	113						
Cast-iron anchor body												
Diameter	D mm						240	270	300	327	360	382
Height	H mm						182	203	227	248	272	294
Thickness 1 st plane	T mm						22	23	27	28	32	34
Hole - dia. top	Lo mm						131	150	163	183	199	208
Hole - dia. bottom	Lu mm						123	139	148	165	176	182
Anchor head												
Diameter	D mm	104	104	115	132	160	180	200	220	245	265	280
Thickness	T mm	65	65	70	75	75	80	82	92	105	120	125
Diameter	A mm	68	77	79	89	109	127	146	159	179	195	204
Diameter circle e1	mm	45	54	56	66	86	*grid	56	*grid	*grid	*grid	*grid
Diameter circle e2	mm							120				
Trumpet												
Max. outer diameter	mm	70	79	81	91	111	131	147	156	173	184	190
Length	mm	≥200	≥244	≥201	≥247	≥417	≥500	≥553	≥595	≥620	≥544	≥509

* Grid according to Annex A2 page 2/4

Bearing plate see Annex A3

Cast-iron anchor body

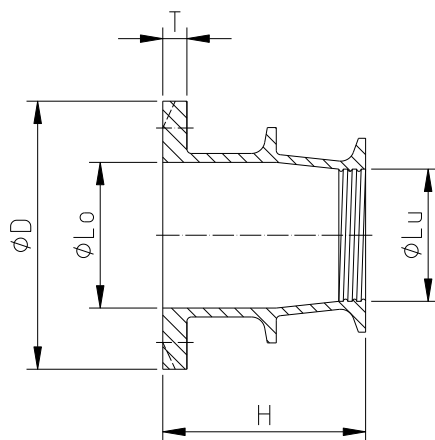

Anchor head

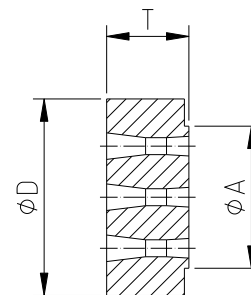

BBV-Internal Bonded Strand Post-tensioning System, type i

Description of the product
Dimensions of Anchor Components

Annex A4

HELIX AND ADDITIONAL REINFORCEMENT (STIRRUPS)

Tendon Type		L3	L4	L5	L7	L9	L12	L15	L19	L22	L27	L31
Helix												
Bar Diameter												
$f_{cmj,cube}=28/30 \text{ N/mm}^2$	mm	14	14	14	14	14	14	14	16	16	16	16
$f_{cmj,cube}=34 \text{ N/mm}^2$	mm	14	14	14	14	14	14	16	16	16	16	16
$f_{cmj,cube}=40 \text{ N/mm}^2$	mm	14	14	14	14	14	14	14	16	16	16	16
$f_{cmj,cube}=45 \text{ N/mm}^2$	mm	14	14	14	14	14	14	14	16	16	16	16
Outer Diameter												
$f_{cmj,cube}=28/30 \text{ N/mm}^2$	mm	140	160	180	200	240	300	345	390	430	490	520
$f_{cmj,cube}=34 \text{ N/mm}^2$	mm	135	150	170	190	230	300	340	380	410	450	480
$f_{cmj,cube}=40 \text{ N/mm}^2$	mm	130	135	160	190	225	285	320	360	380	430	460
$f_{cmj,cube}=45 \text{ N/mm}^2$	mm	120	120	140	180	220	270	315	340	365	410	430
Min. Length												
$f_{cmj,cube}=28/30 \text{ N/mm}^2$	mm	200	230	250	300	350	350	400	450	450	550	550
$f_{cmj,cube}=34 \text{ N/mm}^2$	mm	180	210	240	270	310	300	350	400	450	470	470
$f_{cmj,cube}=40 \text{ N/mm}^2$	mm	170	200	220	250	290	300	300	350	350	450	450
$f_{cmj,cube}=45 \text{ N/mm}^2$	mm	160	180	200	250	275	250	250	300	300	350	350
Pitch												
$f_{cmj,cube}=28/30 \text{ N/mm}^2$	mm	40	40	40	50	50	50	50	50	50	50	50
$f_{cmj,cube}=34 \text{ N/mm}^2$	mm	40	40	40	50	50	50	50	50	50	50	50
$f_{cmj,cube}=40 \text{ N/mm}^2$	mm	40	40	40	50	50	50	50	50	50	50	50
$f_{cmj,cube}=45 \text{ N/mm}^2$	mm	40	40	40	50	50	50	50	50	50	50	50
Helix Turns												
$f_{cmj,cube}=28/30 \text{ N/mm}^2$	n	6	7	7.5	7	8	8	9	10	10	12	12
$f_{cmj,cube}=34 \text{ N/mm}^2$	n	5.5	6.5	7	6.5	7	7	8	9	10	10.5	10.5
$f_{cmj,cube}=40 \text{ N/mm}^2$	n	5.5	6	6.5	6	7	7	7	8	8	10	10
$f_{cmj,cube}=45 \text{ N/mm}^2$	n	5.0	5.5	7	6	6.5	6	6	7	7	8	8
Stirrup reinforcement												
$f_{cmj,cube}=28/30 \text{ N/mm}^2$	mm	Nos x dia.	Nos x dia.	Nos x dia.	Nos x dia.	Nos x dia.	Nos x dia.	Nos x dia.	Nos x dia.	Nos x dia.	Nos x dia.	Nos x dia.
$f_{cmj,cube}=28/30 \text{ N/mm}^2$	mm	4x Ø10	4x Ø12	4x Ø14	4x Ø14	5x Ø14	6x Ø12	5x Ø14	6x Ø16	7x Ø16	11x Ø16	12x Ø16
$f_{cmj,cube}=34 \text{ N/mm}^2$	mm	4x Ø10	5x Ø10	5x Ø12	5x Ø12	5x Ø14	6x Ø14	8x Ø14	7x Ø16	8x Ø16	9x Ø20	10x Ø20
$f_{cmj,cube}=40 \text{ N/mm}^2$	mm	4x Ø8	4x Ø12	5x Ø12	5x Ø12	5x Ø14	5x Ø16	6x Ø16	7x Ø16	6x Ø20	8x Ø20	10x Ø20
$f_{cmj,cube}=45 \text{ N/mm}^2$	mm	4x Ø8	4x Ø10	4x Ø12	4x Ø12	6x Ø12	5x Ø16	6x Ø16	8x Ø16	8x Ø16	8x Ø20	9x Ø20
Position behind Bearing plate or Cast-iron anchor body												
$f_{cmj,cube}=28/30 \text{ N/mm}^2$	mm	A/B	A/B	A/B	A/B	A/B	A/B	A/B	A/B	A/B	A/B	A/B
$f_{cmj,cube}=28/30 \text{ N/mm}^2$	mm	45 / 60	45 / 70	50 / 75	55 / 95	55 / 80	50 / 70	50 / 95	50 / 90	50 / 80	60 / 60	60 / 55
$f_{cmj,cube}=34 \text{ N/mm}^2$	mm	45 / 55	45 / 50	50 / 55	55 / 65	55 / 75	50 / 65	50 / 55	50 / 70	50 / 65	60 / 65	60 / 55
$f_{cmj,cube}=40 \text{ N/mm}^2$	mm	45 / 55	45 / 60	50 / 50	55 / 60	55 / 70	50 / 70	50 / 65	50 / 60	50 / 75	60 / 65	60 / 55
$f_{cmj,cube}=45 \text{ N/mm}^2$	mm	45 / 50	45 / 55	50 / 60	55 / 75	55 / 50	50 / 65	50 / 60	50 / 55	50 / 50	60 / 60	60 / 55

L3 – L9

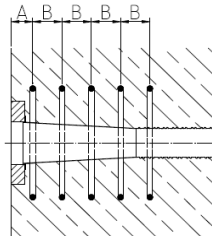

L12 – L31

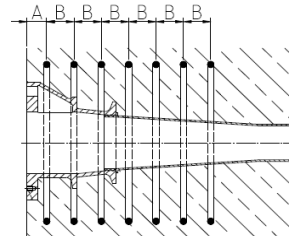

BBV-Internal Bonded Strand Post-tensioning System, type i

Description of the product
Helix and Reinforcement

Annex A5

COUPLER (ÜK)

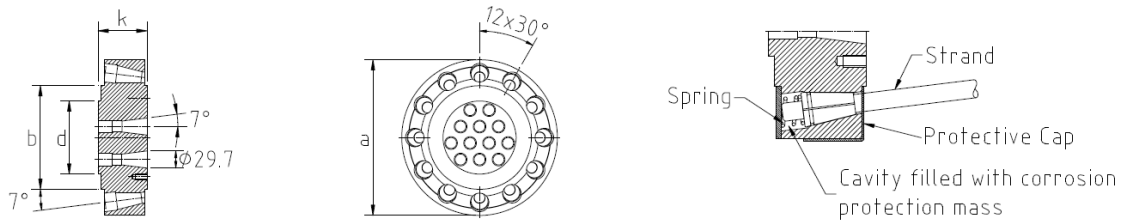

Fixed Coupler (FÜK)

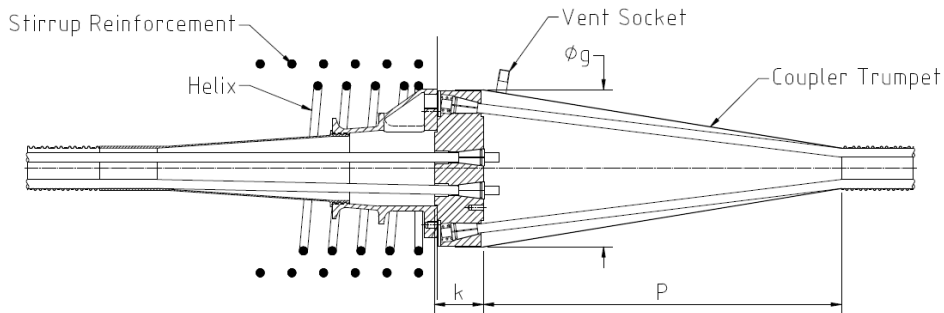

Movable Coupler (BÜK)

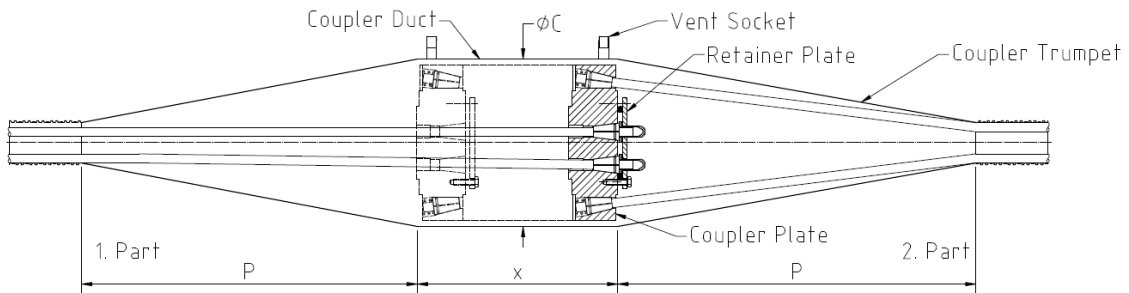

Min. length of coupler duct: for one-end stressing $x = k + 1,15 \Delta l + 30\text{mm}$
for both ends stressing $x = k + 1,15 \Delta l + 60\text{mm}$ ($\Delta l = \text{elongation}$)

Tendon type		L3	L4	L5	L7	L9	L12	L15	L19	L22	L27	L31
Coupler Plate												
Diameter a	mm	194	194	205	222	245	270	290	310	335	380	405
Thickness k	mm	85	85	85	85	85	85	90	98	110	120	130
Diameter bearing area b	mm	104	104	115	132	160	180	200	220	245	265	280
Coupler Trumpet												
Length p	mm	≥440	≥420	≥440	≥490	≥545	≥605	≥640	≥710	≥765	≥875	≥920
Diameter fixed coupler g	mm	197	197	208	225	248	273	293	313	338	383	408
Diameter movable coupler C	mm	214	214	225	242	265	290	310	330	355	400	425

Anchor plate, trumpet, helix and reinforcement see Annexes A4 and A5

BBV-Internal Bonded Strand Post-tensioning System, type i

Description of the product
Couple (ÜK)

Annex A6

DIMENSIONS AND PROPERTIES OF 7-WIRE STRANDS

Designation	Symbol	Unit	Value	
Tensile strength	R_m/F_{pk}	MPa	1770 or 1860	
Strand				
Nominal diameter	D	mm	15,3	15,7
Nominal cross section	A_p	mm ²	140	150
Nominal mass	M	g/m	1093	1172
Surface configuration	-	-	plain	
Strength at 0,1%	$f_{p0,1k}$	MPa	1520 or 1600*	
Strength at 0,2%	$f_{p0,2}$	MPa	1570 or 1660	
Modulus of elasticity	E	MPa	≈ 195.000	
Individual wires				
External wire diameter	d	mm	$5,0 \pm 0,04$	$5,2 \pm 0,04$
Core wire diameter	d'	mm	1,02 to 1,04 d	1,02 to 1,04 d

As long as EN 10138 does not exist 7-wire strands in accordance with national provisions and with the characteristics given in the table above shall be used.

- * If admissible in the place of use, strands with higher characteristic yield stresses might be used, but not more than $f_{p0,1k} = 1560 \text{ N/mm}^2$ (Y1770 S7) or 1640 N/mm^2 (Y1860 S7).

BBV-Internal Bonded Strand Post-tensioning System, type i

Description of the product
7-wire strands

Annex A7

1 Intended use

The Post-Tensioning System is assumed to be used for internal bonded tendons for normal-weight concrete structures or elements.

No optional use category is intended. The structural members used to be designed in accordance with national regulations.

2 Methods of verification

2.1 General

The structural members prestressed by means of the BBV-Internal Bonded Strand Post-Tensioning System used to be designed in accordance with national regulations.

2.2 Tendons

Prestressing and over-tensioning forces are specified in the respective national provisions.

The maximum force P_{max} applied to a tendon shall not exceed the force $P_{max} = 0.9 A_p f_{p0,1k}$ (see Table B 1 (140 mm²) or Table B 2 (150 mm²) for $f_{p0,1k} = 1520$ N/mm² or 1600 N/mm²). The value of the prestressing initial prestress force $P_{m0}(x)$ applied to the concrete after tensioning and anchoring shall not exceed the force $P_{m0}(x) = 0.85 A_p f_{p0,1k}$ (see Table B 1 (140 mm²) or Table B 2 (150 mm²) for $f_{p0,1k} = 1520$ N/mm² or 1600 N/mm²).

Table B 1: Maximal prestressing forces¹ for tendons with $A_p = 140$ mm²

Tendon Designation	Number of strands	Cross section A_p [mm ²]	Prestressing force Y1770 S7 $f_{p0,1k} = 1520$ N/mm ²		Prestressing force Y1860 S7 $f_{p0,1k} = 1600$ N/mm ²	
			$P_{m0}(x)$ [kN]	P_{max} [kN]	$P_{m0}(x)$ [kN]	P_{max} [kN]
BBV L3	3	420	543	575	571	605
BBV L4	4	560	724	766	762	806
BBV L5	5	700	904	958	952	1008
BBV L7	7	980	1266	1341	1333	1411
BBV L9	9	1260	1628	1724	1714	1814
BBV L12	12	1680	2171	2298	2285	2419
BBV L15	15	2100	2713	2873	2856	3024
BBV L19	19	2660	3437	3639	3618	3830
BBV L22	22	3080	3979	4213	4189	4435
BBV L27	27	3780	4884	5171	5141	5443
BBV L31	31	4340	5607	5937	5902	6250

¹ The forces stated in Tables B 1 to B 3 are maximum values referring on $f_{p0,1k} = 1520$ N/mm² or 1600 N/mm². The actual prestressing forces are to be found in national regulations valid in the place of use. If admissible in the place of use, strands with higher characteristic yield stresses might be used, but not more than $f_{p0,1k} = 1560$ N/mm² (Y1770 S7) or 1640 N/mm² (Y1860 S7). In this case the prestressing forces of Tables B 1 to B 3 can be linearly increased by multiplying them with the factor $(f_{p0,1k} / 1520)$ or $(f_{p0,1k} / 1600)$.

Compliance with the stabilisation and crack width criteria in the load transfer test was verified to a load level of $0,80 \cdot F_{pk}$.

BBV-Internal Bonded Strand Post-tensioning System, type i

Intended Use
Methods of verification

Annex B1
Page 1/4

Table B 2: Maximal prestressing forces¹ for tendons with $A_p = 150 \text{ mm}^2$

Tendon Designation	Number of strands	Cross section A_p [mm ²]	Prestressing force Y1770 S7 $f_{p0,1k} = 1520 \text{ N/mm}^2$		Prestressing force Y1860 S7 $f_{p0,1k} = 1600 \text{ N/mm}^2$	
			$P_{m0}(x)$ [kN]	P_{max} [kN]	$P_{m0}(x)$ [kN]	P_{max} [kN]
			BBV L3	3	450	581
BBV L4	4	600	775	821	816	864
BBV L5	5	750	969	1026	1020	1080
BBV L7	7	1050	1357	1436	1428	1512
BBV L9	9	1350	1744	1847	1836	1944
BBV L12	12	1800	2326	2462	2448	2592
BBV L15	15	2250	2907	3078	3060	3240
BBV L19	19	2850	3682	3899	3876	4104
BBV L22	22	3300	4264	4514	4488	4752
BBV L27	27	4050	5233	5540	5508	5832
BBV L31	31	4650	6008	6361	6324	6696

The number of strands in a tendon may be reduced by leaving out strands lying radial-symmetrically in the anchor head (not more than four strands). The provisions for tendons with anchors (basic types) completely filled also apply to tendons with anchor heads only partly filled. Into the free drills in the anchor head the short pieces of strands with wedges have to be pressed to prevent slipping out. The admissible prestressing force is reduced per strand left out as shown in Table B 3.

Table B 3: Reduction of the prestressing force¹ when leaving out a strand

A_p	Y1770 S7		Y1860 S7	
	$\Delta P_{m0}(x)$ [kN]	ΔP_{max} [kN]	$\Delta P_{m0}(x)$ [kN]	ΔP_{max} [kN]
140 mm ²	181	192	190	201
150 mm ²	194	205	204	216

Further characteristic values of the tendons (mass per meter, ultimate stressing force F_{pk}) see Annex A2.

2.3 Radius of curvature of the tendons in the structure

The smallest admissible radii of curvature are given in Annex B3, section 4.2.

2.4 Concrete strength

Concrete complying with EN 206-1:2000, EN 206-1/A1:2004 and EN 206-1/A2:2005 shall be used.

At the time of transmission of the full prestressing force the mean concrete strength of the normal weight concrete in the anchor zone shall be at least $f_{cmj,cube}$ or $f_{cmj,cyl}$ according to Table B 4. The mean concrete strength shall be verified by means of at least three specimens (cylinder or cube with the edge length of 150 mm), which shall to be stored under the same conditions as the concrete member, with the individual values of specimen not differ more than 5 %.

BBV-Internal Bonded Strand Post-tensioning System, type i

Intended Use
Methods of verification

Annex B1
Page 2/4

Table B 4: Necessary mean concrete strength f_{cmj} of the specimens at time of prestressing

$f_{cmj,cube}$ [N/mm ²]	$f_{cmj,cyl}$ [N/mm ²]
28 ^{*)} /30 ^{**)}	23 ^{*)} /25 ^{**)}
34	28
40	32
45	35

*) 12 to 31 strands

***) 3 to 9 strands

For partial prestressing with 30 % of the full prestressing the minimum value of the concrete compressive strength to be proved is $0.5 f_{cmj,cube}$ or $0.5 f_{cmj,cyl}$; intermediate values can be interpolated lineally.

2.5 Centre and edge distances of the tendon anchorages, concrete cover

The centre and edge distances of the tendon anchorages must not be smaller than the values given in the Annexes depending on the minimum concrete strength. In case of anchorages BBV L3 to BBV L9 the large side of the bearing plate (side length a according to Annex A4) shall be installed parallel to the large concrete side (the maximum spacing of concrete axis).

The values of the centre or edge distances of the anchors given in the Annexes may be reduced in one direction up to 15 %, however, not to a smaller value than the external dimensions of the additional reinforcement (stirrups or the outer diameter of the helix, Annex A5). In this case the centre and the edge distances in the other direction shall be increased for keeping the same concrete area in the anchor zone.

All centre and edge distances have only been specified with a view to load transfer to the structure; therefore, the concrete cover given in national standards and provisions shall be taken into account additionally.

2.6 Reinforcement in the anchorage zone

The anchorages (including reinforcement) for the transfer of the prestressing forces to the structural concrete are verified by means of tests. The resistance to the forces occurring in the structural concrete in the anchorage zone outside (behind) the helix shall be verified. An adequate transverse reinforcement shall be provided here in particular for the occurring transverse tension forces (not shown in the attached drawings).

The steel grades and dimensions of the additional reinforcement (stirrups) shall follow the values given in the Annexes. This reinforcement must not be taken into account as part of the statically required reinforcement. However, existing reinforcement in a corresponding position more than the statically required reinforcement may be taken into account for the additional reinforcement. The given reinforcement consists of closed stirrups (stirrups closed by means of bends or hooks or an equivalent method). The stirrup locks (bends or hooks) shall be placed staggered.

In the anchorage zone vertically led gaps for concreting shall be provided for concreting properly. If in exceptional case² - due to an increased amount of reinforcement - the helix or the concrete cannot be properly placed, the helix can be replaced by different equivalent reinforcement.

² This requires the approval for individual case according to the national regulations and administrative provisions.

BBV-Internal Bonded Strand Post-tensioning System, type i

Intended Use
Methods of verification

Annex B1
Page 3/4

2.7 Slip at the anchorages

The slip at the anchorages (see Annex B2, section 3.1.5) shall be taken into account in the static calculation and the determination of the tendon elongation.

2.8 Resistance to fatigue of the anchorages and couplers

With the fatigue tests carried out in accordance with ETAG 013, the stress range of 80 N/mm² of the strands at the maximum stress of 0.65 f_{pk} at 2×10^6 load cycles was demonstrated.

2.9 Increased tension losses at couplers

For verification of crack control and stress ranges increased tension losses of prestressing forces shall be taken into account at the couplers due to creep and shrinkage of the concrete. The losses in prestressing force of the tendons, determined without the influence of the couplers, shall be multiplied in the coupling zone by the factor 1.5. No increase need be taken into account for the movable couplers.

2.10 Couplers

The couplers shall only be used if the calculated stressing force at the coupler is at least 0.7 $P_{m0}(x)$ (see Annex B2, section 2.2). Couplers shall be positioned in straight tendon sections with straight length of at least 1.0 m to each side. For movable couplers the position and length of the coupler duct shall ensure that a movement is possible over the length of at least $1.15 \Delta\ell + 30$ mm, where $\Delta\ell$ is the maximum elongation length at the time of prestressing.

For movable couplers BÜK it shall be ensured that the final position of the coupler plate after prestressing corresponds to that shown in the lower figure of Annex A6.

The prestressing force in the 2nd construction stage of fixed couplers shall be lower than in the 1st construction stage.

electronic copy of the eta by dibt: eta-05/0202

BBV-Internal Bonded Strand Post-tensioning System, type i	Annex B1 Page 4/4
Intended Use Methods of verification	

3 Assumptions under which the performance of the product for the intended use was favourably assessed

3.1 Installation

3.1.1 General

Assembly and installation of the tendons shall only be performed by qualified post-tensioning specialist companies which have the required technical skills and experiences with this BBV-Post-tensioning System. The company's site manager shall have a certificate of the ETA holder certifying that he is instructed by the ETA holder and has the required knowledge and experience with this post-tensioning system. Standards and regulations valid on site shall be considered.

The ETA holder is responsible to inform anyone concerned about the use of this BBV-Post-tensioning System. Additional information as listed in ETAG 013, Section 9.2 shall be held available at the ETA holder and shall be distributed as needed.

The tendons and the components shall be handled carefully.

3.1.2 Welding

Welding at the anchorages is only permitted at the following points:

- a) Welding of the end of the helix to a closed ring.
- b) For ensuring of the central position the helix may be attached to the bearing plate or anchor body by tack-welding.

After placing the strands in the ducts, no more welding shall be performed at the anchorages.

3.1.3 Installation of the tendon

The central position of the helix or stirrups shall be ensured by tack-welding to the bearing plate or the anchor body or by means of mounting brackets. The bearing plate or anchor body and the anchor head shall be in direction vertical to the axis of the tendon.

The tendon shall be placed straightforward the first meter at the anchorage.

PE pipes shall be fixed in the right position and the length of the trumpets shall ensure the right deflection angle of the strands (see section 1.8 of European Technical Assessment).

The connection between trumpet and duct shall be sealed carefully by tape in order to prevent the penetrating of concrete.

3.1.4 Coupler

The outer strands shall be colour-marked for showing the necessary depth of putting in.

3.1.5 Wedging force, slip at anchorages, wedge securing and corrosion protection mass

If the calculated prestressing force is less than $0.7 P_{m0}(x)$ or if knurled wedges type 30 are used, the wedges of fixed anchorages shall be pre-wedged with $1.1 P_{m0}(x)$ (see Annex B1, section 2.2).

The wedges of movable couplers in the parallel drills shall be pre-wedged with $1.1 P_{m0}(x)$ (see Annex B1, section 2.2), if knurled wedges type 30 are used.

Without pre-wedging the slip within the anchorage to be taken into account for the determination of the elongations is 4 mm at the fixed anchorages and 8 mm at the movable couplers. In the case of hydraulic pre-wedging with $1.1 P_{m0}(x)$ no slip shall be taken into account for the determination of the elongations, except for couplers (4 mm).

BBV-Internal Bonded Strand Post-tensioning System, type i

Intended Use
Installation

Annex B2
Page 1/2

The wedges of all anchorages (fixed anchors and couplers) which are no more accessible during tensioning shall be secured by means of securing plates and bolts. The wedging area of fixed anchors to be cast in concrete and of inner part of movable couplers shall be filled with corrosion protection mass (Denso-Jet, Vaseline FC 284 or Nontribos MP-2) and provided with a sealing cap filled with corrosion protection mass (see Annexes A3 and A6). Compositions of the different types of these masses have been deposited with the Deutsches Institut für Bautechnik by the manufacturer. In the case of couplers the voids of the outer coupler tendon (see Annex A6) shall be filled with corrosion protection mass.

The wedges of the stressing anchors shall be pre-wedged after tensioning with at least $0.1 P_{m0}(x)$. In this case the slip is 3 mm. If the wedges are not compressed, the slip shall be about 6 mm (a reset plate shall be used to fix the wedges).

3.1.6 Tensioning

Before tensioning the minimum mean concrete strength shall comply with the values given in Annex B1, section 2.4.

It is admissible to restress the tendons by releasing and re-using the wedges. After restressing and anchoring, wedge marks on the strands resulting from first stressing shall be moved to the outside by at least 15 mm.

The minimum straight length for tensioning behind the anchorages (strand protrusion) is given in Annexes 2 to 5. All strands of a tendon shall be stressed simultaneously. This can be done by centrally controlled individual jacks or by a collective jack.

3.1.7 Grouting

3.1.7.1 Grout and Grouting procedures

Grout according section 2.1.9 shall be used. Grouting procedures shall be carried out in accordance with EN 446:2008.

3.1.7.2 Water rinse

Normally, tendons shall not be rinsed with water.

3.1.7.3 Grouting speed

The grouting speed shall be in the range between 3m/min and 12m/min.

3.1.7.4 Grouted section and re-grouting

The length of a grouted section shall not exceed 120 m for tendons BBV L3 to L22, 95 m for tendons BBV L27 and 80 m for BBV L31. When exceeding these tendon lengths, additional grouting openings shall be provided. Where the tendon is led via distinct high points, re-groutings shall be performed in order to avoid voids. For re-groutings corresponding measures shall be taken into account already in design.

3.1.7.5 Surveillance

Surveillance according to EN 446:2008 shall be carried out.

3.1.8 Packaging, transport and storage

The components and the tendons shall be protected against moisture and staining.

The tendons shall be kept away from areas where welding procedures are performed.

During transport the smallest admissible diameter of curvature of tendons with duct up to 22 strands is 1.65 m and exceeding 22 strands is 2.0 m. For tendons without duct the smallest diameter of curvature during transport is 1.65 m.

electronic copy of the eta by dibt: eta-05/0202

BBV-Internal Bonded Strand Post-tensioning System, type i	Annex B2 Page 2/2
Intended Use Installation	

4 Description of the BBV Internal Bonded strand post-tensioning system

4.1 Tendons

The tendons consist of 7-wire strands with a nominal diameter of 0.60" (15,3 mm) and a nominal cross section of 140 mm² or with a nominal diameter of 0.62" (15,7 mm) and a nominal cross section of 150 mm². Steel grades Y1770 S7 or Y1860 S7 are allowed. Anchorages depending on the tendon sizes are identically for both steel grades.

Table B 5: The strands are bundled to the following tendons and stressing forces:

Steel Grade		Y1770	Y1770	Y1860	Y1860
Nominal Diameter		0.60"	0.62"	0.60"	0.62"
Tendon Designation	No. of strands	P _{m0(x)} [kN]	P _{m0(x)} [kN]	P _{m0(x)} [kN]	P _{m0(x)} [kN]
BBV L 3	3	543	581	571	612
BBV L 4	4	724	775	762	816
BBV L 5	5	904	969	952	1020
BBV L 7	7	1266	1357	1333	1428
BBV L 9	9	1628	1744	1714	1836
BBV L 12	12	2171	2326	2285	2448
BBV L 15	15	2713	2907	2856	3060
BBV L 19	19	3437	3682	3618	3876
BBV L 22	22	3979	4264	4189	4488
BBV L 27	27	4884	5233	5141	5508
BBV L 31	31	5607	6008	5902	6324

Based on $f_{p0,1k} = 1520 \text{ N/mm}^2$ (Sorte Y 1770) and 1600 N/mm^2 (Grade Y 1860)

$$P_{m0(x)} = 0,85 \times f_{p0,1k} \times A_p$$

The number of strands in a tendon can be reduced by omitting single strands always maintaining a symmetrical pattern.

Table B 6: Reduction of stressing force if one strand is omitted

Ø	Steel Grade Y1770 S7		Steel Grade Y1860 S7	
	ΔP _{m0(x)} [kN]	ΔP _{max} [kN]	ΔP _{m0(x)} [kN]	ΔP _{max} [kN]
0.60"	181	192	190	201
0.62"	194	205	204	216

The strands of tendons are combined in a duct without spacer. They are stressed simultaneously and anchored individually in the anchor head by means of wedges.

Round profiled corrugated ducts are used according to EN 523 and connected by threaded couplers. For tendons BBV L 3 and BBV L 4 oval ducts can also be used. All duct connections are sealed carefully by PVC tape.

BBV-Internal Bonded Strand Post-tensioning System, type i

Intended Use
Description of Prestressing System

Annex B3
Page 1/5

4.2 Radius of curvature of the tendons in the structure

The smallest admissible radius of curvature of the tendons with circular duct depending on the strand strength, the cross section of the strand and the diameter of the duct is given in Table B 7 to B 10.

Table B 7: Smallest radius of curvature³ (circular duct) for strands
Y1770 S7 with $A_p = 140 \text{ mm}^2$

Tendon	Radius of curvature [m] (Inner diameter of the duct [mm])		
BBV L 3	3.50 (40)		
BBV L 4	4.20 (45)	4.10 (50)	3.90 (55)
BBV L 5	4.70 (50)	4.40 (55)	4.20 (60)
BBV L 7	4.80 (55)	4.50 (60)	4.40 (65)
BBV L 9	5.30 (65)	5.10 (70)	4.90 (75)
BBV L 12	6.10 (75)	5.90 (80)	5.90 (90)
BBV L 15	7.00 (80)	6.70 (85)	6.50 (90)
BBV L 19	7.90 (90)	7.60 (95)	
BBV L 22	8.20 (100)	7.80 (110)	
BBV L 27	9.20 (110)	8.90 (115)	
BBV L 31	10.00 (115)	9.50 (125)	

Table B 8: Smallest radius of curvature³ (circular duct) for strands
Y1770 S7 with $A_p = 150 \text{ mm}^2$

Tendon	Radius of curvature [m] (Inner diameter of the duct [mm])		
BBV L 3	3.70 (40)		
BBV L 4	4.50 (45)	4.40 (50)	4.20 (55)
BBV L 5	4.90 (50)	4.60 (55)	4.40 (60)
BBV L 7	5.10 (55)	4.80 (60)	4.60 (65)
BBV L 9	5.60 (65)	5.30 (70)	5.20 (75)
BBV L 12	6.50 (75)	6.10 (80)	5.80 (90)
BBV L 15	7.40 (80)	7.10 (85)	6.80 (90)
BBV L 19	8.50 (90)	8.00 (95)	
BBV L 22	8.90 (100)	8.20 (110)	
BBV L 27	9.90 (110)	9.40 (115)	
BBV L 31	10.80 (115)	10.00 (125)	

³ The given smallest admissible radii of curvature refer on the maximum prestressing forces P_{\max} according to Tables B 1 or B 3. If admissible in the place of use, and if strands with higher characteristic yield stressed will be used, the given radii of curvature shall be linearly increased by multiplying them with the factor $(f_{p0,1k} / 1520)$ or $(f_{p0,1k} / 1600)$ and rounded up in steps of 0.1 m. See also Annex B1, section 2.2.2 and footnote 1.

BBV-Internal Bonded Strand Post-tensioning System, type i

Intended Use
Description of Prestressing System

Annex B3
Page 2/5

Table B 9: Smallest radius of curvatur³ (circular duct) for strands
Y1860 S7 with $A_p = 140 \text{ mm}^2$

Tendon	Radius of curvature [m] (Inner diameter of the duct [mm])		
BBV L 3	3.70 (40)		
BBV L 4	4.40 (45)	4.30 (50)	4.10 (55)
BBV L 5	4.80 (50)	4.50 (55)	4.40 (60)
BBV L 7	5.00 (55)	4.70 (60)	4.50 (65)
BBV L 9	5.40 (65)	5.20 (70)	5.00 (75)
BBV L 12	6.30 (75)	6.00 (80)	5.70 (90)
BBV L 15	7.20 (80)	6.90 (85)	6.70 (90)
BBV L 19	8.20 (90)	7.80 (95)	
BBV L 22	8.60 (100)	8.00 (110)	
BBV L 27	9.60 (110)	9.20 (115)	
BBV L 31	10.50 (115)	9.70 (125)	

Table B 10: Smallest radius of curvatur³ (circular duct) for strands
Y1860 S7 with $A_p = 150 \text{ mm}^2$

Tendon	Radius of curvature [m] (Inner diameter of the duct [mm])		
BBV L 3	4.00 (40)		
BBV L 4	4.70 (45)	4.60 (50)	4.40 (55)
BBV L 5	5.00 (50)	4.70 (55)	4.50 (60)
BBV L 7	5.50 (55)	5.00 (60)	4.70 (65)
BBV L 9	6.00 (65)	5.50 (70)	5.30 (75)
BBV L 12	6.90 (75)	6.50 (80)	5.90 (90)
BBV L 15	7.60 (80)	7.20 (85)	7.00 (90)
BBV L 19	9.10 (90)	8.60 (95)	
BBV L 22	9.40 (100)	8.60 (110)	
BBV L 27	10.50 (110)	10,10 (115)	
BBV L 31	11.60 (115)	10.60 (125)	

According to ETAG 013 for tendons with at least five strands and circular ducts the following formula for calculation of the minimal radius of curvature can be used if admissible at the place of use:

$$R_{\min} = \frac{2 \cdot P_{m0,\max} \cdot d_{\text{strand}}}{p_{R,\max} \cdot d_{\text{duct}}}$$

with

- R_{\min} minimum admissible radius of curvature in [m]
- $P_{m0,\max}$ $P_{m0,\max} = 0.85 A_p f_{p0,1k}$ according to Annex B 1, section 2.2 in [kN]
- d_{strand} diameter of the strands in [mm]
- $p_{R,\max}$ maximum admissible pressure under a strand ($p_{R,\max} = 130$ to 150 kN/m)
- d_{duct} inner duct diameter in [mm]

R_{\min} shall be given with an accuracy of 0.1m (shall be rounded up).

BBV-Internal Bonded Strand Post-tensioning System, type i

Intended Use
Description of Prestressing System

Annex B3
Page 3/5

The smallest admissible radius of curvature of the tendons with oval duct depending on the bending axis is given in Table B 11. For oval ducts bending only is allowed around one axis (the stiff or the weak).

Table B 11: Smallest radius of curvature³ (oval duct)

Tendon	Inner duct dimensions [mm x mm]	Radius of curvature [m]	
		Bending axis	
		stiff	weak
BBV L 3	60 x 21	5.30	2.50
BBV L 4	80 x 21	7.20	2.50

5 Anchorages

The anchorage with anchor plate or anchor body and anchor head is used as active anchor or accessible passive anchor. If the anchor head is tack welded to the anchor plate/anchor body and sealed, this type can also be used as an embedded anchorage. Within the anchorage zone the corrugated duct is replaced by a trumpet (PE or steel) with a larger diameter, in which the strands are deflected by a maximum of 2.6° or 2.1° respectively (see section 1.8 of European Technical Assessment). If using a steel trumpet, this one shall be equipped with a PE-inlet. Consecutive part is the anchor plate /anchor body and anchor head with 3 to 31 conical borings – depending on the tendon size – in which the strands are anchored with round wedges, each consisting of three segments.

For anchorage of dia. 0.62” strands wedges with marking “0.62” on the front face shall be installed. The wedges of the embedded passive anchors have to be sealed and secured by a retainer plate.

The bursting forces caused by the load transfer to the concrete member shall be carried by a helix made of ribbed steel. Additional reinforcement such as straight bars or stirrups is required. At the fixed anchors without pre-wedging the slip is 4 mm.

At the stressing anchors the slip is 3 mm (see Annex B2, section 3.1.5).

6 Couplers

Tendons can be coupled with fixed or movable couplers. The coupler consists of a coupler disc in which the strands of the arriving tendon are anchored in the same way as in the active anchor. The strands of the departing tendon are held in a radial pattern of conical borings and anchored by three-segment wedges in the coupler. These wedges are retained by a spring and a lock washer in their seating. The coupler is pre-assembled and consists of a coupler plate, a lock washer and a cover cap for the conical holes which is removed prior for installation of the tendon. The cones are filled with corrosion protection mass.

The correct position of the strands within the coupler is checked by marks on the strands. During the stressing of the tendon a wedge slip of 4 mm occurs due to the seating of these wedges, if the arriving tendon is pre-wedged. Without pre-wedging the slip of a movable coupler is 8 mm (see Annex B2, section 3.1.5).

7 Stressing

A hydraulic pump unit and a special jack are used for the stressing of tendons. All strands of a tendon are stressed simultaneously. Stressing in load steps and resetting of the jacks is easily done. After stressing, the round wedges are power seated by means of a seating device within the jack. A wedge slip of approx. 3 mm remains after the wedge seating procedure.

Straight tendons strands can be stressed individually by mono jacks.

BBV-Internal Bonded Strand Post-tensioning System, type i

Intended Use
Description of Prestressing System

Annex B3
Page 4/5

8 Grouting

For bond and corrosion protection of the strands, the ducts are grouted after stressing. The grout is injected into the grouting cap or through grout pipes. The ducts are vented at the ends of the tendons by means of venting pipes or grouting caps.

Intermediate venting points are necessary in case of long tendons. Couplers are always equipped with vents. Grouting shall be executed in accordance with national regulations and standards.

BBV-Internal Bonded Strand Post-tensioning System, type i

Intended Use
Description of Prestressing System

Annex B3
Page 5/5

1 Performance of the Product

1.1 Losses due to friction and wobble effects

The losses due to friction may usually be determined in the calculation by using the friction coefficients μ and the unintentional angular displacement k (wobble coefficient) given in the Annex A2. The values μ and k depend on the given duct dimensions and distances between tendon supports.

The given values of k only apply if the strands are in the ducts at the time of concreting.

If the strands are arranged after concreting, the given values μ shall only be used in the calculation if the ducts are adequately stiffened during concreting, e.g. by means of PE and/or PVC pipes, or if reinforced ducts are used in connection with smaller distances between tendon supports.

For the determination of strains and forces of prestressing steel friction losses $\Delta P_{\mu S}$ in the stressing anchor zone and $\Delta P_{\mu \ddot{U}K}$ in the movable coupling zone (see Annex A2) shall be taken into account.

BBV-Internal Bonded Strand Post-tensioning System, type i	Annex C1
Performance of the Product	

1. Technical details of realization of the system of assessment and verification of constancy of performance and CE-marking

1.1 System of Verification and Assessment of Constancy of Performance

According to the decision 98/456/EC of the European Commission⁴ System 1+ of the attestation of conformity applies.

This system of attestation of conformity is defined as follows:

System 1+: declaration of conformity of the product by a notified body on the basis of:

- (a) Tasks for the manufacturer:
 - (1) Factory production control
 - (2) Further testing of samples taken at the factory by the manufacturer in accordance with a prescribed test plan
- (b) Tasks for the notified body:
 - (3) Initial type-testing of the product
 - (4) Initial inspection of factory and of factory production control
 - (5) Continuous surveillance, assessment and assessment of factory production control
 - (6) Audit-testing of samples taken at the factory

1.2 Responsibilities

1.2.1 Tasks of the manufacturer

1.2.1.1 Factory production control

The kit manufacturer shall keep available an updated list of all components manufacturers. The list is provided to the notified body and to the Technical Assessment Body.

The kit manufacturer shall exercise permanent internal control of production. All the elements, requirements and provisions adopted by the kit manufacturer shall be documented in a systematic manner in the form of written policies and procedures, including records of results performed. This production control system shall insure that the product is in conformity with this European Technical Assessment.

The kit manufacturer may only use initial materials stated in the technical documentation of this European Technical Assessment.

The factory production control shall be in accordance with the Control Plan of January 2016 relating to the European Technical Assessment ETA-05/0202 which is part of the technical documentation of this European Technical Assessment. The Control Plan is laid down in the context of the factory production control system operated by the manufacturer and deposited with Deutsches Institut für Bautechnik.⁵

The basic elements of the Control Plan comply with ETAG 013, Annex E1.

⁴ Official Journal of the European Communities L 201/112 of 3 July 1998

⁵ The "Control Plan" is a confidential part of the European Technical Assessment and only handed over to the notified notifizierten involved in the system of assessment and verification of constancy of performance. See section 1.2.2.

BBV-Internal Bonded Strand Post-tensioning System, type i

Technical details concerning the implementation of the system of assessment and verification of constancy of performance and CE-marking

Annex D1
Page 1/3

The records shall contain at least the following information:

- Designation of the product or of the initial material and the components
- Kind of control or testing
- Date of manufacture and of testing of product or components and of initial material
- Results of controls and tests and, where specified, comparison with the requirements
- Name and signature of person responsible for the factory production control

The records shall be kept for at least ten years and on request they shall be presented to Deutsches Institut für Bautechnik.

If the test result is not satisfactory, the kit manufacturer shall take immediate measures to eliminate the deficiency. Construction products and components which do not comply with the requirements shall be handled such that they cannot be mistaken for products complying with the requirements. After elimination of the deficiency the relevant test shall be immediately repeated as far as is technically possible and necessary for verifying the deficiency elimination.

1.2.1.2 Declaration of performance and other tasks of manufacturer

The kit manufacturer shall, on the basis of a contract, involve a body which is notified for the tasks referred to in section 1.1 in the field of Post-Tensioning Kits for prestressing of Structures in order to undertake the actions laid down in section 1.2.2. For this purpose, the control plan referred to in sections 1.2.1.1 and 1.2.2 shall be handed over to the notified body involved by the manufacturer.

The kit manufacturer shall provide a certificate of constancy of performance by the notified body, stating that the construction product is in conformity with the provisions of the European Technical Assessment ETA-05/0202.

For the product a declaration of performance shall be drawn up. The producer can draw up a declaration of performance for the essential characteristics due to section 3 of this European Technical Assessment if the acceptance criteria due to ETAG 013 are fulfilled and the the certificate of constancy of performance of a notified body is available.

Specimens shall be taken from construction works currently in progress at least once a year on which one series of single tensile element test in accordance with ETAG 013, Annex E3 shall be performed. The results of these test series shall be made available to the notified body.

At least once a year, each components manufacturer shall be audited by the kit manufacturer (see ETAG 013, 8.2.1.1).

1.2.2 Tasks of the notified Body

1.2.2.1 General

The notified body shall perform the measures according to sections 1.2.2.2 to 1.2.2.5 and in accordance with the provisions laid down in the "Control Plan of January 2016 relating to the European Technical Assessment ETA-05/0202".

The notified body shall retain the essential points of its actions referred to above and state the results obtained and conclusions drawn in written reports.

The notified body involved by the kit manufacturer shall issue a certificate of constancy of performance of the product stating that all rules for the assessment and verification of constancy of performance and the performance named in the European Technical Assessment have to be due to System 1+ and stating compliance of the construction product with all applicable requirements.

In cases where the provisions of the European Technical Assessment and its "Control Plan" are no longer fulfilled the notified body shall withdraw the declaration of conformity and inform Deutsches Institut für Bautechnik without delay.

electronic copy of the eta by dibt: eta-05/0202

BBV-Internal Bonded Strand Post-tensioning System, type i	
Technical details concerning the implementation of the system of assessment and verification of constancy of performance and CE-marking	Annex D1 Page 2/3

1.2.2.2 Initial type-testing

For initial type-testing the results of the tests performed as part of the assessment for the European Technical Assessment may be used unless there are changes in the production line or plant. In such cases the necessary initial type-testing has to be agreed between the Deutsches Institut für Bautechnik and the notified body involved.

1.2.2.3 Initial inspection of factory and of factory production control

The notified body shall ascertain that, in accordance with the "Control Plan", the factory, in particular the staff and equipment, and the factory production control are suitable to ensure a continuous and orderly manufacturing of the Post-tensioning system with the specifications mentioned in section 1 of the Specific Part of the European Technical Assessment ETA-05/0202 as well as in the Annexes to the European Technical Assessment.

1.2.2.4 Continuous surveillance, assessment and assessment of factory production control

The notified body shall visit the factory at least once a year. Each factory of the components listed in Annex D2 shall be audited at least once in five years. It has to be verified that the system of factory production control and the specified manufacturing process are maintained taking account of the "Control Plan".

Continuous surveillance and assessment of factory production control have to be performed according to the control plan.

The results of product certification and continuous surveillance shall be made available on demand by the notified body to the Deutsches Institut für Bautechnik.

1.2.2.5 Audit-testing of samples taken at the kit manufacturer

During surveillance inspections the notified body shall take samples of components of the Post-tensioning system for independent testing. For the most important components Annex D3 contains the minimum procedures which have to be performed by the notified body.

The basic elements of the Audit testing comply with ETAG 013, Annex E2 (see Annex D3).

1.3 CE marking

The CE marking shall be affixed on the delivery note. The letters "CE" shall be followed by the identification number of the notified body, if applicable, and be accompanied by the following additional information:

- The name or identifying mark of the kit manufacturer and of the production plant (legal entity responsible for the manufacture),
- The last two digits of the year in which the CE marking was affixed,
- The number of the certificate of constancy of performance for the product,
- The number of the European Technical Assessment,
- The number of the Guideline for European Technical Approval,
- The identification of the product (trade name)
- The nominal cross sectional area and the characteristic value of tensile strength of the strands

electronic copy of the eta by dibt: eta-05/0202

BBV-Internal Bonded Strand Post-tensioning System, type i	Annex D1 Page 3/3
Technical details concerning the implementation of the system of assessment and verification of constancy of performance and CE-marking	

CONTENT OF CONTROL PLAN

Component	Item	Test/Check	Traceability ⁴	Minimum frequency	Documentation
Bearing plate for 3 to 9 strands	material	check	bulk	100 %	"2.2" ¹
	detailed dimensions ⁵	test		3 % ≥ 2 specimen	yes
	visual inspection ³	check		100 %	no
Cast-iron anchor body for 12 to 31 strands	material	check	full	100 %	"3.1" ²
	detailed dimensions ⁵	test		5% ≥ 2 specimen	yes
	visual inspection ³	check		100 %	no
Anchor head	material	check	full	100 %	"3.1" ²
	detailed dimensions ⁵	test		5 % ≥ 2 specimen	yes
	visual inspection ³	check		100 %	no
Coupler	material	check	full	100 %	"3.1" ²
	detailed dimensions ⁵	test		5 % ≥ 2 specimen	yes
	visual inspection ³	check		100 %	no
Wedge	material	check	full	100 %	"3.1" ²
	treatment, hardness	test		0,5 % ≥ 2 specimen	yes
	detailed dimensions ⁵	test		5 % ≥ 2 specimen	yes
	visual inspection ³	check		100 %	no
Duct	material	check	full	100 %	"CE"
	visual inspection ³	check		100 %	no

Continuation of Control Plan and footnotes see Annex D2 page 2/2

BBV-Internal Bonded Strand Post-tensioning System, type i

Control Plan

Annex D2
Page 1/2

CONTENT OF CONTROL PLAN - CONTINUED -

Component	Item	Test/Check	Traceability ⁴	Minimum frequency	Documentation
Tensile element strand	material ⁶	check	full	100 %	yes
	diameter	test		each coil/bundle	no
	visual inspection ³	check		each coil/bundle	no
Constituents of filling material as per EN 447	cement	check	full	100 %	yes
	admixtures, additions	check	full	100 %	yes
Helix	material	check	full	100 %	yes
	visual inspection ³	check		100 %	no
Stirrups	material	check	full	100 %	yes
	visual inspection ³	check		100 %	no
Springs for couplers	material	check	full	100 %	"2.2" ¹
	visual inspection ³	check		100 %	no
Grease	material ⁷	check	full	100 %	"2.2" ¹
Wax	material ⁸	check	full	100 %	"2.2" ¹

All samples shall be randomly selected and clearly identified.

¹ "2.2" : Test report type "2.2" according to EN 10204

² "3.1" : Inspection certificate type "3.1" according to EN 10204

³ Visual inspections means e.g.: Main dimensions, gauge testing, correct marking or labelling, appropriate performance, surface, fins, kinks, smoothness, corrosion, coating, etc., as given in the Control Plan

⁴ full : Full traceability of each component to its raw material.

bulk : Traceability of each delivery of components to a defined point.

⁵ Detailed dimensions mean measuring of all dimensions and angles according to the specification as given in the Control Plan

⁶ Characteristic material properties see Annex A7

⁷ Grease according to the composition deposited by the supplier at the Deutsches Institut für Bautechnik. Characteristic material properties shall comply with ETAG 013, Annex C4.1

⁸ Wax according to the composition deposited by the supplier at the Deutsches Institut für Bautechnik. Characteristic material properties shall comply with ETAG 013, Annex C4.2

BBV-Internal Bonded Strand Post-tensioning System, type i

Control Plan

Annex D2
Page 2/2

AUDIT TESTING

Component	Item	Test/Check	Sampling - Number of components per visit
Anchor head	material according to specification	check, test	1
	detailed dimensions	test	
	visual inspection ¹	check	
Cast-iron anchor body	material according to specification	check, test	1
	detailed dimensions	test	
	visual inspection ¹	check	
Coupler	material according to specification	check, test	1
	detailed dimensions	test	
	visual inspection ¹	check	
Wedge	material according to specification	check, test	2
	treatment	test	2
	detailed dimensions	test	1
	main dimensions, surface hardness	test	5
	visual inspection ¹	check	5
Single tensile element	ETAG 013 Annex E.3	test	1 series

¹ Visual inspections means e.g.: Main dimensions, gauge testing, correct marking or labelling, appropriate performance, surface, fins, kinks, smoothness, corrosion, etc.

All samples shall be randomly selected and clearly identified.

BBV-Internal Bonded Strand Post-tensioning System, type i

Audit Testing

Annex D3

MATERIAL OF COMPONENTS AND RELATED STANDARDS

Designation	Material	Material code	Standard
Bearing plates	S235JR	1.0038	EN 10025-2:2004
Cast-iron anchor bodies	deposited at Deutsches Institut für Bautechnik		
Wedges	deposited at Deutsches Institut für Bautechnik		
Anchor heads	C45+N	1.0503	EN 10083-2:2006
Couplers	C45+N	1.0503	EN 10083-2:2006
Springs for couplers	deposited at Deutsches Institut für Bautechnik		
Helixes for S, F, Fe, FÜK ¹	$R_e = 500 \text{ MPa}$ $f_{yk} \geq 500 \text{ MPa}$, $\epsilon_{uk} \geq 50 \text{ ‰}$		The local standards and provisions at the site of use shall apply.
Additional reinforcement for S, F, Fe, FÜK (stirrups) ¹	$R_e = 500 \text{ MPa}$		EN 10080:2005-08
Securing plates for wedges	S235JR	1.0038	EN 10025-2:2004
Trumpets	steel or PE deposited at Deutsches Institut für Bautechnik		
PE pipes and caps	PE deposited at Deutsches Institut für Bautechnik		
Corrosion protection mass Nontribus MP-2 ² (grease)	deposited at Deutsches Institut für Bautechnik		
Corrosion protection mass Vaseline FC 284 ² (wax)	deposited at Deutsches Institut für Bautechnik		
Corrosion protection mass Denso - Jet ² (wax)	deposited at Deutsches Institut für Bautechnik		

The technical documentation of the components of this European Technical Approval is deposited at the Deutsches Institut für Bautechnik

¹ deposited at Deutsches Institut für Bautechnik

² corrosion protection mass (wax or grease) according to the composition deposited by the supplier at the Deutsches Institut für Bautechnik. Characteristic material properties shall comply with ETAG 013, Annex C4.1 or C4.2.

BBV-Internal Bonded Strand Post-tensioning System, type i

Material of components

Annex E1

Codes and References

- prEN 10138-3:2009 Prestressing Steels - Part 3: Strand
- EN 523:2003-11 Steel Strip Sheaths for Prestressing tendons
- EN 447:2008-01 Grout for Prestressing Tendons – Basic Requirements
- ETAG 013:2002-06 Guideline for European Technical Approval of post-tensioning kits for prestressing of structures
- EN 206-1:2001-07 Concrete – Part 1: Specification, Performance, Production an Conformity
- EN 206-1/A1:2004-10 Concrete – Part 1: Specification, Performance, Production an Conformity; German Version EN 206-1:200/A1:2004
- EN 206-1/A2:2005-09 Concrete – Part 1: Specification, Performance, Production an Conformity; German Version EN 206-1:200/A2:2005
- EN 446:2008-01 Grout for Prestressing Tendons – Grouting procedures
- EN 10204:2005-01 Metallic Products – Types of Inspection Documents
- EN 10025-2:2005-04 Holt Rolled Products of Structural Steels – Part 2: Technical Delivery Conditions for Non-Alloy Structural Steels
- EN 10083-2:2006-10 Quenched and Tempered Steels – Part 2: Technical Delivery Conditions for Unalloyed

BBV-Internal Bonded Strand Post-tensioning System, type i

Codes and References

Annex E2