

Approval body for construction products
and types of construction

Bautechnisches Prüfamt

An institution established by the Federal and
Laender Governments



European Technical Assessment

ETA-08/0307
of 27 August 2015

English translation prepared by DIBt - Original version in German language

General Part

Technical Assessment Body issuing the
European Technical Assessment:

Deutsches Institut für Bautechnik

Trade name of the construction product

Hilti screw anchor HUS

Product family
to which the construction product belongs

Concrete screw for use in concrete

Manufacturer

Hilti Aktiengesellschaft
9494 SCHAAN
FÜRSTENTUM LIECHTENSTEIN

Manufacturing plant

Hilti Werke

This European Technical Assessment
contains

15 pages including 3 annexes which form an integral part
of this assessment

This European Technical Assessment is
issued in accordance with Regulation (EU)
No 305/2011, on the basis of

Guideline for European technical approval of "Metal
anchors for use in concrete", ETAG 001 Part 3: "Undercut
anchors", April 2013,
used as European Assessment Document (EAD)
according to Article 66 Paragraph 3 of Regulation (EU)
No 305/2011.

This version replaces

ETA-08/0307 issued on 29 April 2014

The European Technical Assessment is issued by the Technical Assessment Body in its official language. Translations of this European Technical Assessment in other languages shall fully correspond to the original issued document and shall be identified as such.

Communication of this European Technical Assessment, including transmission by electronic means, shall be in full. However, partial reproduction may only be made with the written consent of the issuing Technical Assessment Body. Any partial reproduction shall be identified as such.

This European Technical Assessment may be withdrawn by the issuing Technical Assessment Body, in particular pursuant to information by the Commission in accordance with Article 25(3) of Regulation (EU) No 305/2011.

Specific Part

1 Technical description of the product

The Hilti screw anchor HUS is made of galvanised steel (HUS-A; -H; -I; -P) of sizes 6 and 10 or made of stainless steel (HUS-HR; -CR) of sizes 6, 8, 10 and 14. The anchor is screwed into a predrilled cylindrical drill hole. The special thread of the anchor cuts an internal thread into the member while setting. The anchorage is characterised by mechanical interlock in the special thread.

The product description is given in Annex A.

2 Specification of the intended use in accordance with the applicable European Assessment Document

The performances given in Section 3 are only valid if the anchor is used in compliance with the specifications and conditions given in Annex B.

The verifications and assessment methods on which this European Technical Assessment is based lead to the assumption of a working life of the anchor of at least 50 years. The indications given on the working life cannot be interpreted as a guarantee given by the producer, but are to be regarded only as a means for choosing the right products in relation to the expected economically reasonable working life of the works.

3 Performance of the product and references to the methods used for its assessment

3.1 Mechanical resistance and stability (BWR 1)

Essential characteristic	Performance
Characteristic values for resistance to tension and shear load, bending moment, edge distance and spacing, minimum thickness of member and displacements	See Annex C

3.2 Safety in case of fire (BWR 2)

Essential characteristic	Performance
Reaction to fire	Anchorage satisfy requirements for Class A1
Resistance to fire	See Annex C

3.3 Safety in use (BWR 4)

For Basic Works Requirement Safety in use the same criteria are valid as for Basic Works Requirement Mechanical resistance and stability.

4 Assessment and verification of constancy of performance (AVCP) system applied, with reference to its legal base

In accordance with guideline for European technical approval ETAG 001, April 2013, used as European Assessment Document (EAD) according to Article 66 Paragraph 3 of Regulation (EU) No 305/2011, the applicable European legal act is: [96/582/EC].

The system to be applied is: 1

English translation prepared by DIBt

5 Technical details necessary for the implementation of the AVCP system, as provided for in the applicable European Assessment Document

Technical details necessary for the implementation of the AVCP system are laid down in the control plan deposited with Deutsches Institut für Bautechnik.

Issued in Berlin on 27 August 2015 by Deutsches Institut für Bautechnik

Uwe Bender
Head of Department

beglaubigt:
Baderschneider

Product and installed condition

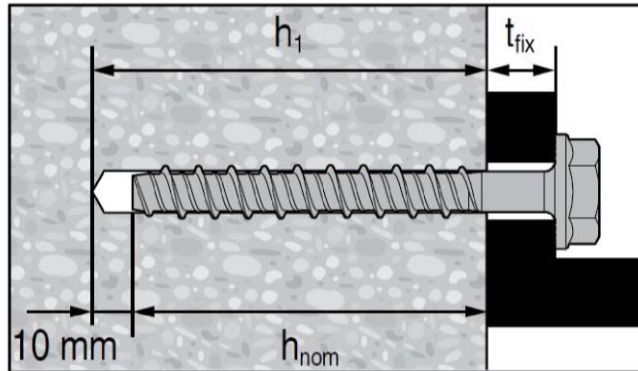

HUS-H (hexagonal head, sizes 6 and 10);
HUS-HR (hexagonal head, sizes 6, 8, 10 and 14)

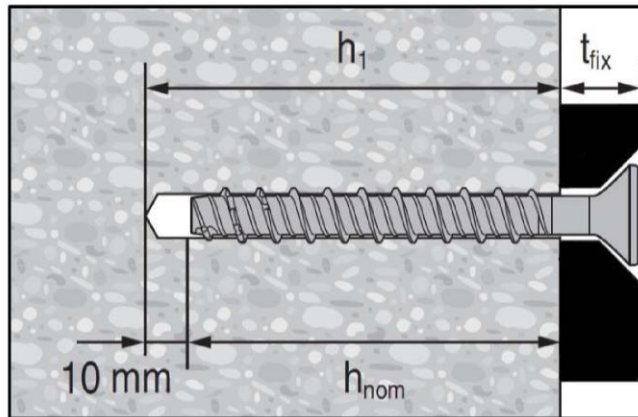

HUS-CR (countersunk head, sizes 8 and 10)

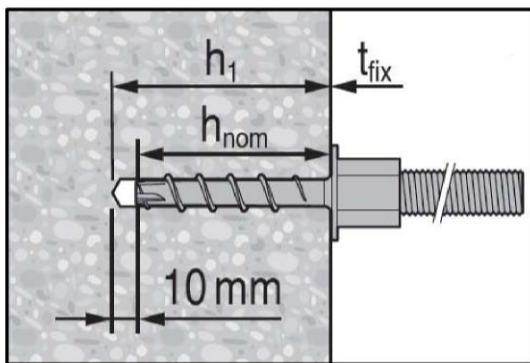

HUS-I (hexagonal head with internal metric thread,
size 6)

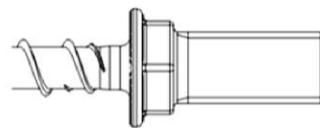

HUS-A (external thread,
size 6)



HUS-H (hexagonal head,
size 6)

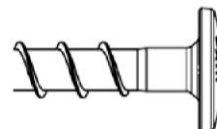

HUS-P (pan head,
size 6)

Hilti screw anchor HUS

Product description
Installed condition Example

Annex A1

Table A1: Material and screw types

Part	Designation	f_{yk}	f_{uk}	d_s	d_k	A_s	A_5	Material
		[N/mm ²]	[N/mm ²]	[mm]	[mm]	[mm ²]	[%]	
Screw anchor	HUS-A 6	745	930	7,85	5,85	26,9	≤ 8	Carbon Steel, galvanized (≥ 5 µm)
	HUS-H 6							
	HUS-I 6							
	HUS-P 6							
	HUS-H 10	860	1000	12,3	8,4	55,4	> 8	Stainless Steel (A4 grade)
	HUS-HR 6	900	1050	7,6	5,4	22,9		
	HUS-HR 8	745	870	10,1	7,05	39,0		
	HUS-CR 8	745	870	10,1	7,05	39,0		
	HUS-HR 10	815	950	12,3	8,40	55,4		
	HUS-CR 10							
HUS-HR 14	590	690	16,6	12,6	143,1			

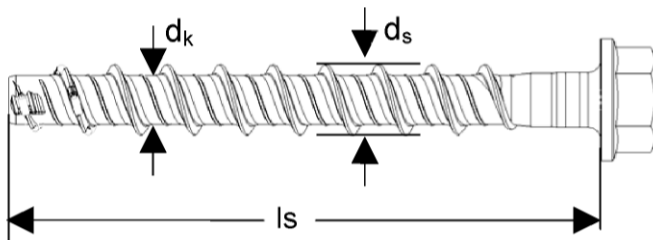

Head stamp:

e.g. Hilti HUS-HR 8 x ...
or circle marks

Hilti cutting edges:

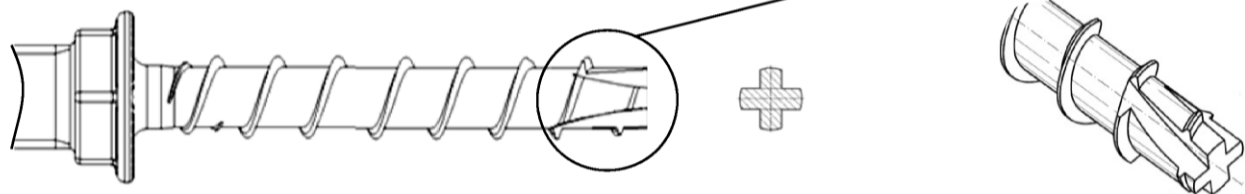

HILTI

... Manufacturer

Hilti cutting edges

... Hilti Universal Screw anchor, anchor diameter/ drill bit diameter 6 mm

HUS

... Hilti Universal Screw anchor

e.g. „H“ resp. circle marks

... Head configuration (A, H, I, P, C, R)

R

... Corrosion Resistance (stainless steel, grade A4)

8

... Nominal anchor diameter/ drill bit diameter (6...14)

...

... Nominal anchor length (l_s)/ under head length

} Type

Hilti screw anchor HUS

Product description
Material and screw types

Annex A2

Screw types

HUS-A 6

External thread
M8 or M10

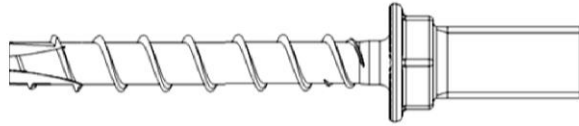

Circle mark with $d = 2,5 \text{ mm}$ for $h_{nom} = 55 \text{ mm}$

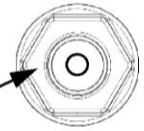

HUS-H 6

Hex head

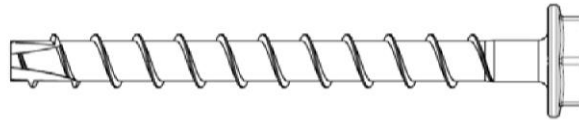

HUS-I 6

Internal threads
M8 and M10

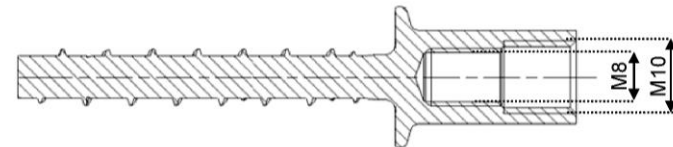
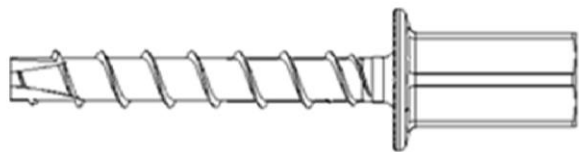

Two circle marks with $d = 0,8 \text{ mm}$ for $h_{nom} = 55 \text{ mm}$

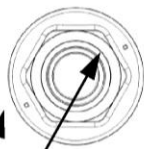

HUS-P 6

Pan head

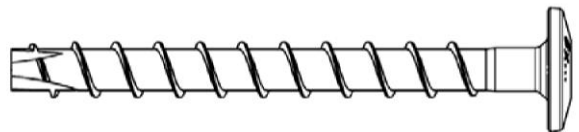

HUS-H 10

Hex head

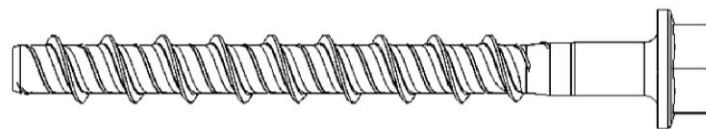

HUS-HR 6

HUS-HR 8

HUS-HR 10

HUS-HR 14

Hex head

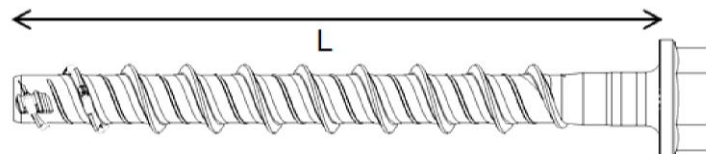

HUS-CR 8

HUS-CR 10

Countersunk head

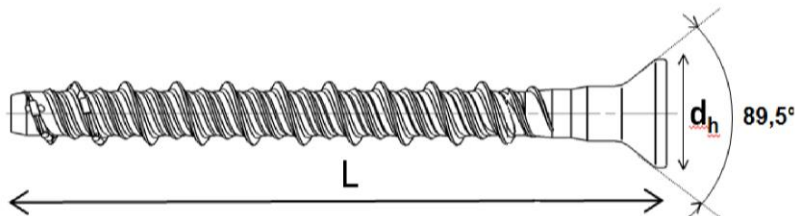

Hilti screw anchor HUS

Product description
Screw types

Annex A3

Specifications of the intended use

Anchorage subject to:

- Static and quasi-static loads: all sizes and all embedment depths.
- Seismic action for Performance Category C1: sizes 8, 10 and 14 for maximum embedment depth only.
- Fire exposure: sizes 10 and 14 only HUS-H (hex head); Size 6 all head configuration.

Base materials:

- Reinforced or unreinforced normal weight concrete according to EN 206:2013.
- Strength classes C20/25 to C50/60 according to EN 206:2013.
- Non-cracked and cracked concrete: all sizes and all embedment depths.

Use conditions (Environmental conditions)

- The anchors may only be used in dry internal conditions: All screw types
- Structures subject to external atmospheric exposure (including industrial and marine environment) and to permanently damp internal condition if no particular aggressive conditions exists: screw types made of stainless steel with marking "R"

Note: Particular aggressive conditions are e.g. permanent, alternating immersion in seawater or the splash zone of seawater, chloride atmosphere of indoor swimming pools or atmosphere with extreme chemical pollution (e.g. in desulphurization plants or road tunnels where de-icing materials are used)

Design:

- Anchorages are designed under the responsibility of an engineer experienced in anchorages and concrete work.
- Verifiable calculation notes and drawings are prepared taking account of the loads to be anchored. The position of the anchor is indicated on the design drawings (e. g. position of the anchor relative to reinforcement or to supports, etc.).
- Anchorages under static or quasi-static actions are designed in accordance with:
 - ETAG 001, Annex C, design method A, Edition August 2010 or
 - CEN/TS 1992-4:2009, design method A
- Anchorages under seismic action are designed in accordance with:
 - EOTA Technical Report TR 045, Edition February 2013 (Seismic performance category C1).
 - Anchorages shall be positions outside of critical regions (e.g. plastic hinges) of the concrete structure.
 - Fastenings in stand-off installation or with a grout layer are not allowed.
- Anchorages under fire exposure are designed in accordance with:
 - ETAG 001, Annex C, design method A, Edition August 2010 and EOTA Technical Report TR 020, Edition May 2004 or
 - CEN/TS 1992-4:2009, Annex D
 - In case of requirements to resistance to fire local spalling of the concrete cover must be avoided.

Installation:

- Hammer drilling only: all sizes and all embedment depths.
- Anchor installation carried out by appropriately qualified personnel and under the supervision of the person responsible for technical matters of the site.
- In case of aborted hole: new drilling at a minimum distance away of twice the depth of the aborted hole or smaller distance if the aborted hole is filled with high strength mortar and if under shear or oblique tension load it is not the direction of the load application.
- After installation further turning of the anchor is not possible. The head of the anchor is supported on the fixture and is not damaged.

Hilti screw anchor HUS

Intended use
Specifications

Annex B1

Table B1: Installation parameters

Nominal anchor diameter		6					8		10				14	
Type	HUS-	A	H	I	P	HR	HR CR ¹⁾		H		HR CR ¹⁾		HR	
Nominal anchorage depth	h_{nom} [mm]	55					60	80	70	85	70	90	70	110
Nominal diameter of drill bit	d_0 [mm]	6					8		10				14	
Cutting diameter of drill bit	$d_{cut} \leq$ [mm]	6,4					8,45		10,45				14,50	
Clearance hole diameter	d_f [mm]	9					12		14				18	
Wrench size	SW [mm]	13	13	13	-	13	13		15				21	
TORX (H, P and CR types)		-	T30	-	T30	-	T45		-	-	T50		-	
Diameter of countersunk head (CR)	d_h [mm]	-					-	-	-	-	21		-	-
Installation torque	T_{inst} [Nm]	25					- ¹⁾	- ¹⁾	45	55	45 ³⁾		65	35
Setting tool		Impact screw driver, e.g. Hilti SIW 14-A or 22-A ²⁾					Impact screw driver, e.g. Hilti SIW 22T-A ²⁾							
Depth of drill hole in floor/ wall position	$h_1 \geq$ [mm]	$h_{nom}+10$ mm					$h_{nom}+10$ mm		$h_{nom}+10$ mm				$h_{nom}+10$ mm	
Depth of drill hole in ceiling position	$h_1 \geq$ [mm]	$h_{nom}+3$ mm												

¹⁾ Hand setting in concrete base material not allowed (machine setting only)

²⁾ Hilti recommended electrical impact screw drivers are listed in the instruction for use included in the sales box.

³⁾ Installation torque refer to HUS-HR only

Table B2: Minimum thickness of concrete member, minimum edge distance and spacing

Nominal anchor diameter		6					8		10				14	
Type	HUS-	A	H	I	P	HR	HR CR		H		HR CR		HR	
Nominal anchorage depth	h_{nom} [mm]	55					60	80	70	85	70	90	70	110
Minimum member thickness	h_{min} [mm]	100					100	120	110	130	120	140	140	160
Cracked concrete	Minimum edge distance	35					45	50	50	50	50	50	50	60
	Minimum spacing													
Non-cracked concrete	Minimum edge distance	35					45	50	65	65	50	50	50	60
	Minimum spacing													

Hilti screw anchor HUS

Intended use

Installation parameters, Minimum thickness of concrete member, minimum edge distance and spacing

Annex B2

Table B3: Screw length and maximum thickness of fixture for HUS size 6

Anchor size	6				
	A	H	I	P	HR
embedment depth [mm]	h _{nom} 55				
Length of screw [mm]	Thickness of fixture [mm]				
55	0		0		
60		5		5	5
70					15
80		25		25	
100		45			
120		65			

Table B4: Screw length and maximum thickness of fixture for HUS sizes 8, 10, 14

Anchor size type	8				10				14			
	CR		HR		H		HR		CR		HR	
embedment depth [mm]	h _{nom1} 60	h _{nom2} 80	h _{nom1} 60	h _{nom2} 80	h _{nom1} 70	h _{nom2} 85	h _{nom1} 70	h _{nom2} 90	h _{nom1} 70	h _{nom2} 90	h _{nom1} 70	h _{nom2} 110
Length of screw [mm]	Thickness of fixture [mm]											
	t _{fix1}	t _{fix2}	t _{fix1}	t _{fix2}	t _{fix1}	t _{fix2}	t _{fix1}	t _{fix2}	t _{fix1}	t _{fix2}	t _{fix1}	t _{fix2}
65			5									
75	15		15				5				10	
80												
85			25	5			15		15			
90												
95	35	15	35	15			25	5				
100												
105			45	25			35	15	35	15		
110												
115							45	25				
120											50	10
130												
135											65	25
140							60	40				
150												
160												
200					130	115						
240					170	155						
280					210	195						

Hilti screw anchor HUS

Intended use
Screw length and maximum thickness of fixture

Annex B3

Installation instruction

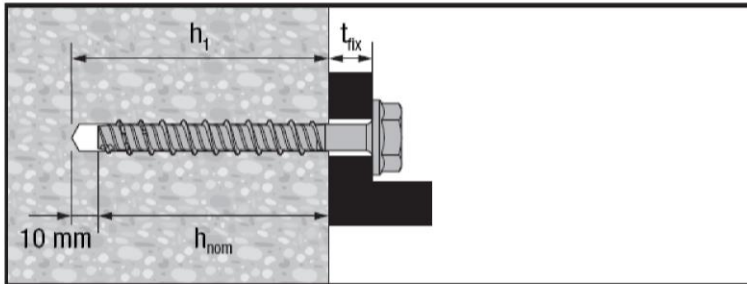

Anchor after installation

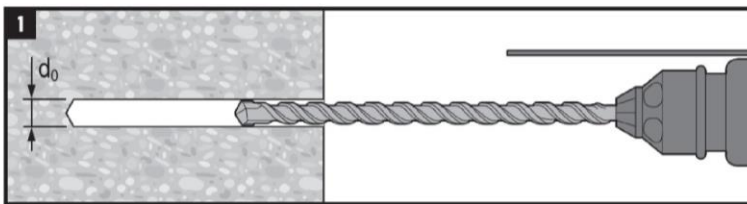

1
Make a cylindrical hole

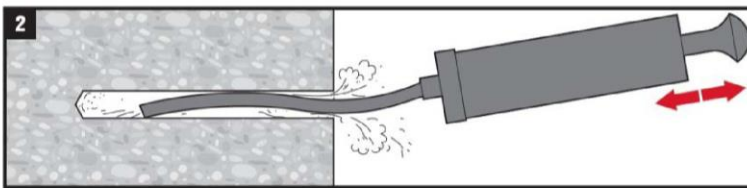

2
Clean the hole

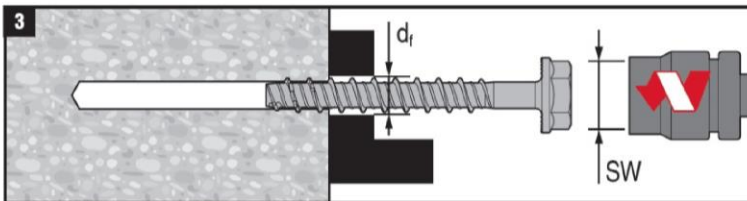

3
Install the screw anchor by torque wrench or impact screw driver
according to Annex B2, Table B1

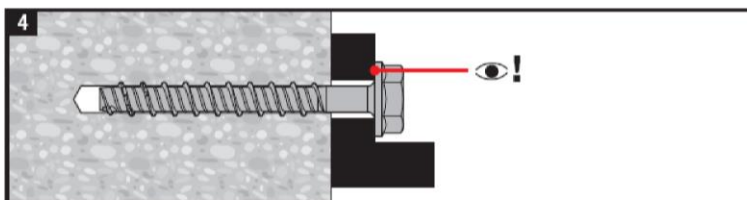

4
Ensure that the head of the anchor is fully supported on the fixture and
it is not damaged.

Hilti screw anchor HUS

Intended use
Installation instruction

Annex B4

Table C1: Characteristic values for static and quasi-static action

Nominal anchor diameter			6			8		10				14	
Type	HUS-	A H I	P	HR	HR CR		H		HR CR		HR		
					60	80	70	85	70	90	70	110	
Nominal anchorage depth	h_{nom}	[mm]	55			60	80	70	85	70	90	70	110
Steel failure for tension and shear load													
Characteristic resistance	$N_{RK,s}$	[kN]	25	24	34,0	55,4	52,6	102,2					
	$V_{RK,s}$	[kN]	12,5	17	26	23,8	33	55	77				
	$k_2^{2)}$	[-]	0,8	1,0	1,0	0,8	1,0	1,0					
	$M^0_{RK,s}$	[Nm]	21	19	36	70	66	193					
Pull-out failure													
Characteristic resistance in cracked concrete C20/25	$N_{RK,p}$	[kN]	6	5	6	12	7,5	16	9	16	12	25	
Characteristic resistance in non-cracked concrete C20/25	$N_{RK,p}$	[kN]	9	7,5	9	12	16	12	20	16	25	- ¹⁾ - ¹⁾	
Increasing factors for $N_{RK,p}$ in cracked and non-cracked concrete	ψ_c	C30/37	1,22		1,22	1,17	1,22		1,22				
		C40/50	1,41		1,41	1,32	1,41		1,41				
		C50/60	1,55		1,55	1,42	1,55		1,55				
Concrete cone and splitting failure													
Effective anchorage depth	h_{ef}	[mm]	42	45	47	64	54	67	54	71	52	86	
Factor for	Cracked	$k_{cr}^{2)}$	7,2										
	Non-cracked	$k_{ucr}^{2)}$	10,1										
Concrete cone failure	Edge distance	$c_{cr,N}$	1,5 h_{ef}		1,5 h_{ef}	1,5 h_{ef}		1,5 h_{ef}		1,5 h_{ef}			
	Spacing	$s_{cr,N}$	3 h_{ef}		3 h_{ef}	3 h_{ef}		3 h_{ef}		3 h_{ef}			
Splitting failure	Edge distance	$c_{cr,sp}$	1,5 h_{ef}		1,5 h_{ef}	1,5 h_{ef}	1,8 h_{ef}	1,8 h_{ef}		1,8 h_{ef}			
	Spacing	$s_{cr,sp}$	3 h_{ef}		3 h_{ef}	3 h_{ef}	3,6 h_{ef}	3,6 h_{ef}		3,6 h_{ef}			
Installation safety factor	$\gamma_2^{3)} = \gamma_{inst}^{2)}$		1,2	1,4	1,2	1,2	1,4	1,2	1,2		1,2		
Concrete pry-out failure													
k factor	$k^{3)} = k_3^{2)}$	[mm]	1,5		2	2		2		2			
Concrete edge failure													
Effective length of anchor	l_f	[mm]	42	45	47	64	54	67	54	71	52	86	
Effective diameter of anchor	d	[mm]	6			8	10		14				

¹⁾ Pull-out is not decisive

²⁾ Parameter relevant only for design according to CEN/TS 1992-4: 2009.

³⁾ Parameter relevant only for design according to ETAG 001 Annex C.

Hilti screw anchor HUS

Performances

Characteristic values for static and quasi-static action

Annex C1

Table C2: Characteristic values for seismic category C1

Nominal anchor diameter			8	10		14		
Type	HUS-		HR CR	H	HR CR	HR		
Nominal anchorage depth	h_{nom}	[mm]	80	85	90	110		
Steel failure								
Characteristic resistance	$N_{Rk,s,seis}$	[kN]	34,0	55,4	52,6	102,2		
	$V_{Rk,s,seis}$	[kN]	11,1	17,9		53,9		
Pull-out failure								
Characteristic resistance in cracked concrete	$N_{Rk,p,seis}$	[kN]	7,7	12,5		17,5		
Concrete cone failure								
Effective embedment depth			64	67	71	86		
Concrete cone failure	Edge distance	$c_{cr,N}$	1,5 h_{ef}					
	Spacing	$s_{cr,N}$	3,0 h_{ef}					
Installation safety factor			γ_2	[-]	1,2	1,4	1,2	1,2
Concrete pry-out failure								
k factor			k	[-]	2,0			
Concrete edge failure								
Effective length of anchor			l_f	[mm]	64	67	71	86
Effective diameter of anchor			d	[mm]	8	10		14

Hilti screw anchor HUS

Performances
Characteristic values for seismic category C1

Annex C2

Table C3: Characteristic values for resistance to fire

Nominal anchor diameter			6		8		10				14		
Type	HUS-	A H I P	HR	HR	H	HR	H	HR	HR	HR	HR		
Nominal anchorage depth	h_{nom}	[mm]	55		60	80	70	85	70	90	70	110	
Steel Failure for tension and shear load ($F_{R,k,s,fi} = N_{R,k,s,fi} = V_{R,k,s,fi}$)													
Characteristic resistance	R30	$F_{Rk,s,fi}$	[kN]	1,6	4,9	9,3	5,0	18,5	41,7				
	R60	$F_{Rk,s,fi}$	[kN]	1,2	3,3	6,3	3,6	12,0	26,9				
	R90	$F_{Rk,s,fi}$	[kN]	0,8	1,8	3,2	2,2	5,4	12,2				
	R120	$F_{Rk,s,fi}$	[kN]	0,7	1,0	1,7	1,5	2,4	5,4				
	R30	$M^0_{Rk,s,fi}$	[Nm]	1,4	4,0	8,2	6,3	19,4	65,6				
	R60	$M^0_{Rk,s,fi}$	[Nm]	1,1	2,7	5,5	4,6	12,6	42,4				
	R90	$M^0_{Rk,s,fi}$	[Nm]	0,7	1,4	2,8	2,8	5,7	19,2				
	R120	$M^0_{Rk,s,fi}$	[Nm]	0,6	0,8	1,5	1,9	2,5	8,5				
Concrete pull-out failure													
Characteristic resistance	R30	$N_{Rk,p,fi}$	[kN]	1,5	1,3	1,5	3,0	1,9	4,0	2,3	4,0	3,0	6,3
	R60												
	R90												
	R120	$N_{Rk,p,fi}$	[kN]	1,2	1,0	1,2	2,4	1,5	3,2	1,8	3,2	2,4	5,0
Edge distance													
	R30 to R120	$c_{cr,N}$	[mm]	2 h_{ef}									
Anchor spacing													
	R30 to R120	$s_{cr,N}$	[mm]	4 h_{ef}									
Concrete pry-out failure													
	R30 to R120	k	[-]	1,5	2	2				2			

Hilti screw anchor HUS

Performances
Characteristic values for resistance to fire

Annex C3

Table C4: Displacement under tension load

Nominal anchor diameter				6			8		10				14	
Type		HUS-	A H I	P	HR	HR CR		H		HR CR		HR		
Nominal anchorage depth		h_{nom}	55			60	80	70	85	70	90	70	110	
Cracked concrete C20/25 to C50/60	Tension load	N	[kN]	2,4	1,7	2,4	4,8	3,0	4,1	3,6	6,3	4,8	9,9	
	Displacement	δ_{N0}	[mm]	0,1	0,4	0,5	0,7	0,2	0,3	0,3	0,6	0,9	1,4	
		$\delta_{N\infty}$	[mm]	0,6	0,5	0,7	1,1	0,3	0,7	0,6	1,1	1,1	1,4	
		$\delta_{N,seis}$	[mm]	-	-	-	1,2	-	1,2	-	1,2	-	0,4	
Non-cracked concrete C20/25 to C50/60	Tension load	N	[kN]	3,6	3,0	3,1	4,8	6,3	4,8	6,8	6,3	9,9	7,5	16,0
	Displacement	δ_{N0}	[mm]	0,2	0,8	0,7	1,6	0,2	0,3	0,3	1,3	0,7	1,0	
		$\delta_{N\infty}$	[mm]	0,3	0,8	0,7	1,6	0,3	0,7	0,3	1,3	0,7	1,0	

Table C5: Displacement under shear load

Nominal anchor diameter				6			8		10				14		
Type		HUS-	A H I	P	HR	H		HR CR		H		HR CR		HR	
Nominal anchorage depth		h_{nom}	55			60	75	60	80	70	85	70	90	70	110
Cracked and Non- cracked concrete C20/25 to C50/60	Shear load	V	[kN]	6,0	7,8	6,9	6,9	11,0	12,4	10,3	10,3	13,6	15,7	12,9	27,3
	Displacement	δ_{V0}	[mm]	1,9	0,4	1,5	1,5	2,0	2,3	1,5	1,5	1,1	1,7	3,5	3,9
		$\delta_{V\infty}$	[mm]	2,8	0,5	2,3	2,3	2,4	2,9	2,3	2,3	1,5	2,4	3,9	4,3
		$\delta_{V,seis}$	[mm]	-	-	-	4,8	-	4,8	-	5,3	-	5,3	-	7,6

Hilti screw anchor HUS

Performances
Displacements

Annex C4