

Approval body for construction products
and types of construction

Bautechnisches Prüfamt

An institution established by the Federal and
Laender Governments



European Technical Assessment

ETA-09/0313
of 28 August 2015

English translation prepared by DIBt - Original version in German language

General Part

Technical Assessment Body issuing the
European Technical Assessment:

Deutsches Institut für Bautechnik

Trade name of the construction product

SMK Nail anchor MND 6

Product family
to which the construction product belongs

Metal anchor made of galvanised steel and stainless steel
of size 6x45, 6x50 and 6x72 for multiple use for non-
structural applications in concrete

Manufacturer

SMK Meister GmbH u. Co. KG
Lombacher Straße 53
72293 Glatten

Manufacturing plant

SMK Meister GmbH u. Co. KG
Lombacher Straße 53
72293 Glatten

This European Technical Assessment
contains

8 pages including 3 annexes which form an integral part
of this assessment

This European Technical Assessment is
issued in accordance with Regulation (EU)
No 305/2011, on the basis of

Guideline for European technical approval of "Metal
anchors for use in concrete", ETAG 001 Part 6: "Anchors
for multiple use for non-structural applications", Edition
August 2010,
used as European Assessment Document (EAD)
according to Article 66 Paragraph 3 of Regulation (EU)
No 305/2011.

The European Technical Assessment is issued by the Technical Assessment Body in its official language. Translations of this European Technical Assessment in other languages shall fully correspond to the original issued document and shall be identified as such.

Communication of this European Technical Assessment, including transmission by electronic means, shall be in full. However, partial reproduction may only be made with the written consent of the issuing Technical Assessment Body. Any partial reproduction shall be identified as such.

This European Technical Assessment may be withdrawn by the issuing Technical Assessment Body, in particular pursuant to information by the Commission in accordance with Article 25(3) of Regulation (EU) No 305/2011.

Specific part

1 Technical description of the product

The SMK Nail anchor MND 6 of size 6x45, 6x50 and 6x72 is an anchor made of zinc-plated steel or stainless steel which is placed into a drilled hole and anchored by load-controlled expansion.

Product and product description is given in Annex A.

2 Specification of the intended use in accordance with the applicable European Assessment Document

The performances given in Section 3 are only valid if the anchor is used in compliance with the specifications and conditions given in Annex B.

The verifications and assessment methods on which this European Technical Assessment is based lead to the assumption of a working life of the anchor of at least 50 years. The indications given on the working life cannot be interpreted as a guarantee given by the producer, but are to be regarded only as a means for choosing the right products in relation to the expected economically reasonable working life of the works.

3 Performance of the product and references to the methods used for its assessment

3.1 Mechanical resistance and stability (BWR 1)

The essential characteristics regarding mechanical resistance and stability are included under the Basic Works Requirement Safety in use.

3.2 Safety in case of fire (BWR 2)

Essential characteristic	Performance
Reaction to fire	Anchorage satisfy requirements for Class A1
Resistance to fire	See Annex C 1

3.3 Safety in use (BWR 4)

Essential characteristic	Performance
Characteristic resistance in concrete	See Annex C 1
Edge distances and spacing	See Annex C 1

4 Assessment and verification of constancy of performance (AVCP) system applied, with reference to its legal base

In accordance with guideline for European technical approval ETAG 001, April 2013 used as European Assessment Document (EAD) according to Article 66 Paragraph 3 of Regulation (EU) No 305/2011 the applicable European legal act is: [97/161/EC].

The system to be applied is: 2+

English translation prepared by DIBt

5 Technical details necessary for the implementation of the AVCP system, as provided for in the applicable EAD

Technical details necessary for the implementation of the AVCP system are laid down in the control plan deposited with Deutsches Institut für Bautechnik.

Issued in Berlin on 28 August 2015 by Deutsches Institut für Bautechnik

Uwe Bender
Head of Department

beglaubigt:
Tempel

Installed condition for MND 6

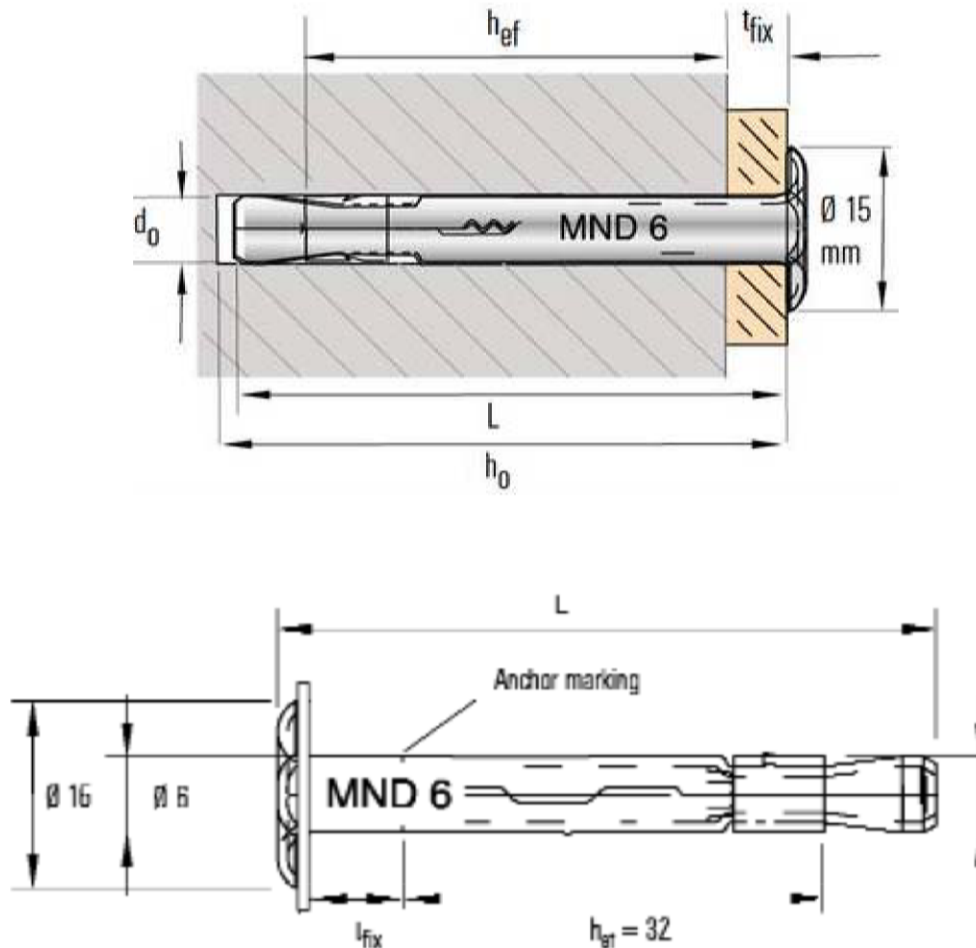

Table A1: Anchor dimension, marking and material

Nail Anchor MND 6			MND 6 x 45	MND 6 x 50	MND 6 x 72
Marking / embossing			MND 6/5	MND 6/10	MND 6/32
Anchor length	L	[mm]	45	50	72
Material steel galvanized			H340LAD Z100 / HX420LAD Z100		
Material stainless steel			1.4404 / 1.4571		
Material high corrosion resistant steel			1.4529		

SMK Nail Anchor MND 6

Product description
Installed condition, anchor types, dimensions and materials

Annex A 1

Specifications of intended use

Anchorage subject to:

- Static and quasi-static loads,
- Used only for multiple use for non-structural applications according to ETAG 001, Part 6,
- Used for anchorages with requirements related to resistance of fire.

Base materials:

- Reinforced or unreinforced normal weight concrete according to EN 206-1:2000-12
- Strength classes C20/25 to C50/60 according to EN 206-1:2000-12
- Non-cracked and cracked concrete

Use conditions (environmental conditions):

- Structures subject to dry internal conditions (all anchor types),
- Structures subject to external atmospheric exposure (including industrial and marine environment) and to permanently damp internal condition, if no particular aggressive conditions exist (anchors of stainless and high corrosion resistant steel),
- Structures subject to particular aggressive conditions (only anchors of high corrosion resistant steel).
Particular aggressive conditions are e.g. permanent, alternating immersion in seawater or the splash zone of seawater, chloride atmosphere of indoor swimming pools or atmosphere with extreme chemical pollution (e.g. in desulphurization plants or road tunnels where de-icing materials are used).

Design:

- The anchorages are to be designed under the responsibility of an engineer experienced in anchorages and concrete work.
- Verifiable calculation notes and drawings shall be prepared taking account of the loads to be anchored, the nature and strength of the base materials and the dimensions of the anchorage members as well as of the relevant tolerances. The position of the anchor shall be indicated on the design drawings (e. g. position of the anchor relative to reinforcement or to supports, etc.).
- Anchorages under static or quasi-static actions are designed in accordance with:
 - ETAG 001, Annex C, design method C, Edition August 2010.
- Anchorages under fire exposure are designed in accordance with:
 - EOTA Technical Report TR 020, Edition May 2004.

Installation:

- Hole drilling by hammer drilling,
- Anchor installation has to be carried out by appropriately qualified personnel and under the supervision of the person responsible for technical matters of the site,
- The anchor may only be set once.

SMK Nail Anchor MND 6

**Intended use
Specifications**

Annex B 1

Table B1: Installation parameters

Nail Anchor MND 6			MND 6 x 45	MND 6 x 50	MND 6 x 72
Nominal drill hole diameter	d_o	[mm]	6	6	6
Drill hole depth	$h_o \geq$	[mm]	$48 - t_{fix}$	$53 - t_{fix}$	$75 - t_{fix}$
Effective anchorage depth	$h_{ef} \geq$	[mm]	32	32	32
Minimum thickness of concrete member	for $t_{fix} > 20\text{mm}$	h_{min}	-	-	80
	for $t_{fix} \leq 20\text{mm}$				100
Maximum thickness of fixture	$\max t_{fix}$	[mm]	5	10	32
Diameter of clearance hole in the fixture	$d_f \leq$	[mm]	7,5		

Installation instructions:

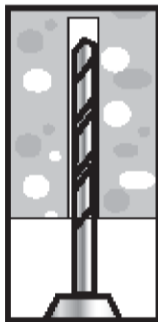

drilling of hole

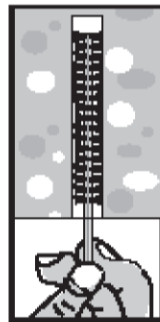

cleaning of drill hole

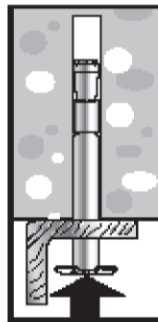

setting anchor through fixture

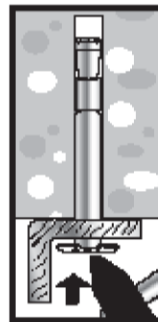

driving in with a hammer

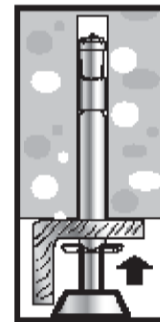

or driving in with a setting tool

SMK Nail Anchor MND 6

Intended use

Installation parameters, edge distance and spacing
Installation instructions

Annex B 2

Table C1: Characteristic values of resistance in concrete in all load directions without lever arm (Design according to ETAG 001, Annex C, design method C)

Nail anchor MND 6			MND 6 x 45 MND 6 x 50 MND 6 x 72	
			Steel galvanized	Stainless and high corrosion resistant steel
All load directions				
Characteristic resistance in concrete C20/25 to C50/60	F_{Rk}	[kN]	3,0	4,0
Partial safety factor	γ_M	[-]	1,5	2,25
Spacing	s_{cr}	[mm]	200	
Edge distance	c_{cr}	[mm]	100	

Table C2: Characteristic values under fire exposure in concrete C20/25 to C50/60 for all load directions without lever arm (Design according to EOTA TR 020)

Fire resistance class	Nail Anchor MND 6			Steel galvanized	Stainless and high corrosion resistant steel
	Characteristic resistance	$F_{Rk,fi}$	[kN]		
R 30	Characteristic resistance	$F_{Rk,fi}$	[kN]	0,35	1,0
R 60				0,25	1,0
R 90				0,15	0,6
R 120				0,1	0,3
R 30 - R 120	Spacing	$s_{cr,fi}$	[mm]	200	
	Edge distance ¹⁾	$c_{cr,fi}$	[mm]	100	

¹⁾ The edge distance shall be ≥ 300 mm if there is a fire to more than one side of the concrete member

SMK Nail Anchor MND 6

Performances

Characteristic resistances in concrete
Design method C according to ETAG 001, Annex C

Annex C 1