

Approval body for construction products  
and types of construction

Bautechnisches Prüfamt

An institution established by the Federal and  
Laender Governments



## European Technical Assessment

**ETA-14/0470**  
**of 1 January 2015**

English translation prepared by DIBt - Original version in German language

### General Part

Technical Assessment Body issuing the  
European Technical Assessment:

Deutsches Institut für Bautechnik

Trade name of the construction product

KEIL undercut anchor KH for porcelain stoneware  
"Casalgrande Padana"

Product family  
to which the construction product belongs

Fastener for the rear fixing of façade panels made of  
ceramic plates (stoneware) according to EN 14411:2012

Manufacturer

Casalgrande Padana spa  
Via Statale 467N 73  
42013 CASALGRANDE (RE)  
ITALIEN

Manufacturing plant

Plant 1

This European Technical Assessment  
contains

17 pages including 3 annexes which form an integral part  
of this assessment

This European Technical Assessment is  
issued in accordance with Regulation (EU)  
No 305/2011, on the basis of

European Assessment Document (EAD) 330030-00-0601  
"Fastener of external wall claddings ",  
Edition November 2014

The European Technical Assessment is issued by the Technical Assessment Body in its official language. Translations of this European Technical Assessment in other languages shall fully correspond to the original issued document and shall be identified as such.

Communication of this European Technical Assessment, including transmission by electronic means, shall be in full. However, partial reproduction may only be made with the written consent of the issuing Technical Assessment Body. Any partial reproduction has to be identified as such.

This European Technical Assessment may be withdrawn by the issuing Technical Assessment Body, in particular pursuant to information by the Commission according to Article 25 Paragraph 3 of Regulation (EU) No 305/2011.

## Specific Part

### Technical description of the product

- 1** The "KEIL undercut anchor KH" is a special anchor consisting of a crosswise slotted anchor sleeve with an M6 internal thread, at the upper edge of which a hexagon is formed to it and a respective hexagon screw with a tooth lock washer formed to it. The anchor sleeve and the hexagon screw with a tooth lock washer formed to it are made of stainless steel. Instead of the hexagon screw a grub screw or threaded rod made of stainless steel may also be used. The anchor is put into an undercut drill hole and by driving-in the screw it is placed form-fitted and deformation-controlled.

The product description is given in Annex A.

- 2** **Specification of the intended use in accordance with the applicable European Assessment Document**

The performances given in Section 3 are only valid if the anchor is used in compliance with the specifications and conditions given in Annex B.

The verifications and assessment methods on which this European Technical Assessment is based lead to the assumption of a working life of the anchors of at least 50 years. The indications given on the working life cannot be interpreted as a guarantee given by the producer, but are to be regarded only as a means for choosing the right products in relation to the expected economically reasonable working life of the works.

- 3** **Performance of the product and references to the methods used for its assessment**

**3.1** **Mechanical resistance and stability (BWR 1)**

Essential characteristic	Performance
Characteristic resistance for tension and shear loads	See Annex C 1
Anchor distances and dimensions of members	See Annex C 1

**3.2** **Safety in case of fire (BWR 2)**

Essential characteristic	Performance
Reaction to fire	Fasteners satisfy requirements for Class A 1
Resistance to fire	No performance determined (NPD)

**3.3** **Hygiene, health and the environment (BWR 3)**

Not applicable

**3.4** **Safety and accessibility (BWR 4)**

Not applicable

English translation prepared by DIBt

**3.5 Protection against noise (BWR 5)**

Not applicable

**3.6 Energy economy and heat retention (BWR 6)**

Not applicable

**3.7 Sustainable use of natural resources (BWR 7)**

Not applicable

**3.8 General aspects**

The verification of durability is part of testing the essential characteristics. Durability is only ensured if the specifications of intended use according to Annex B are taken into account.

**4 Assessment and verification of constancy of performance (AVCP) system applied, with reference to its legal base**

According to Decision of the Commission of 17 February 1997 (97/161/EC) (OJ L 062 of 04.03.97 p. 41-42), the system of assessment and verification of constancy of performance (see Annex V and Article 65 Paragraph 2 to Regulation (EU) No 305/2011) given in the following table applies.

Product	Intended use	Level or class	System
Metal anchors for use in concrete (light-duty type)	For use in redundant systems for fixing and/or supporting to concrete elements such as lightweight suspended ceilings, as well as installations	—	2+

**5 Technical details necessary for the implementation of the AVCP system, as provided for in the applicable European Assessment Document**

Technical details necessary for the implementation of the AVCP system are laid down in the control plan deposited at Deutsches Institut für Bautechnik.

Issued in Berlin on 1 January 2015 by Deutsches Institut für Bautechnik

Uwe Bender  
Head of Department

*beglaubigt:*  
Aksünger

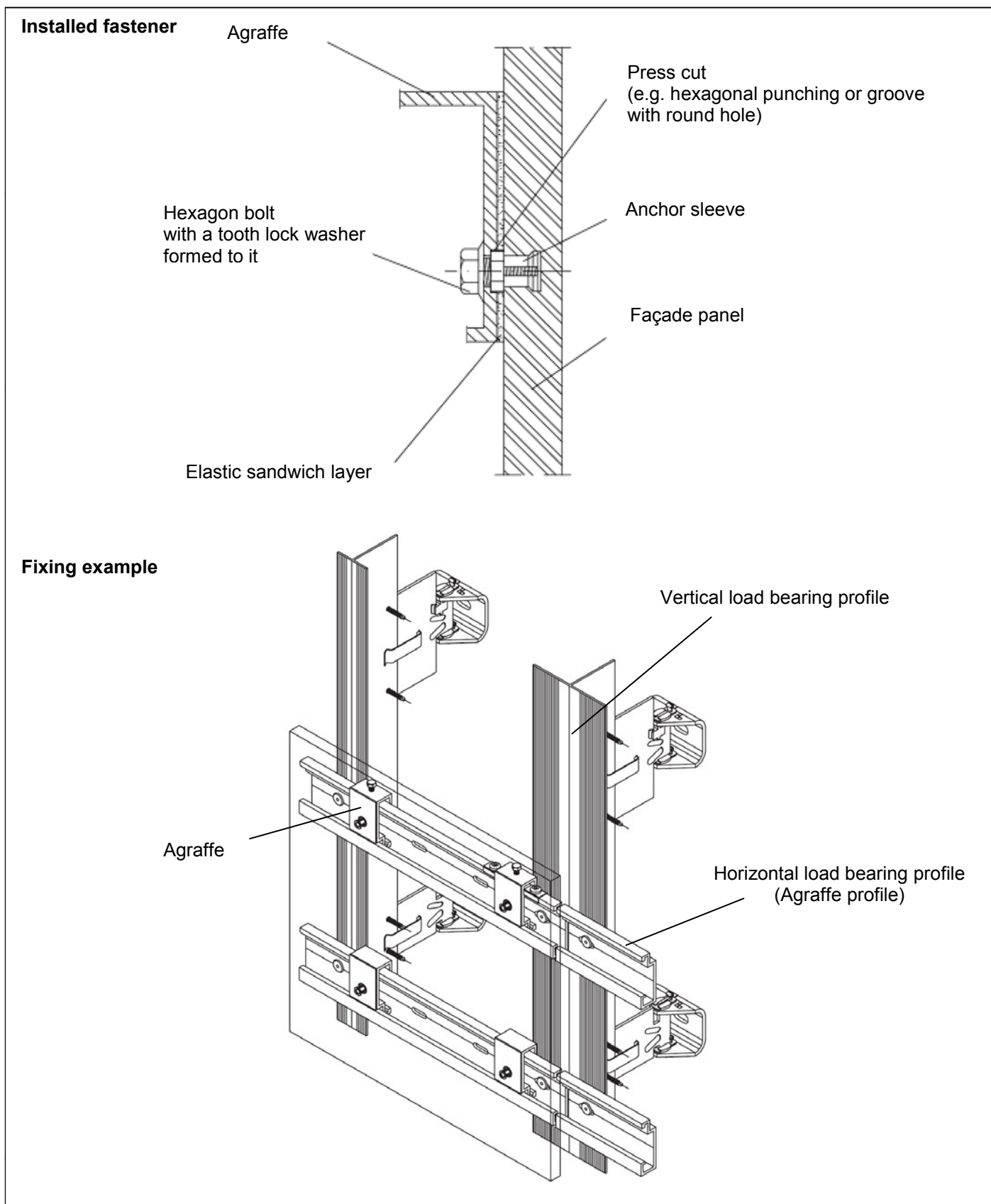

KEIL undercut anchor KH for porcelain stoneware "Casalgrande Padana"

**Product description**  
Installed fastener and fixing example

Annex A 1

**Anchor sleeve (dimension in mm)**

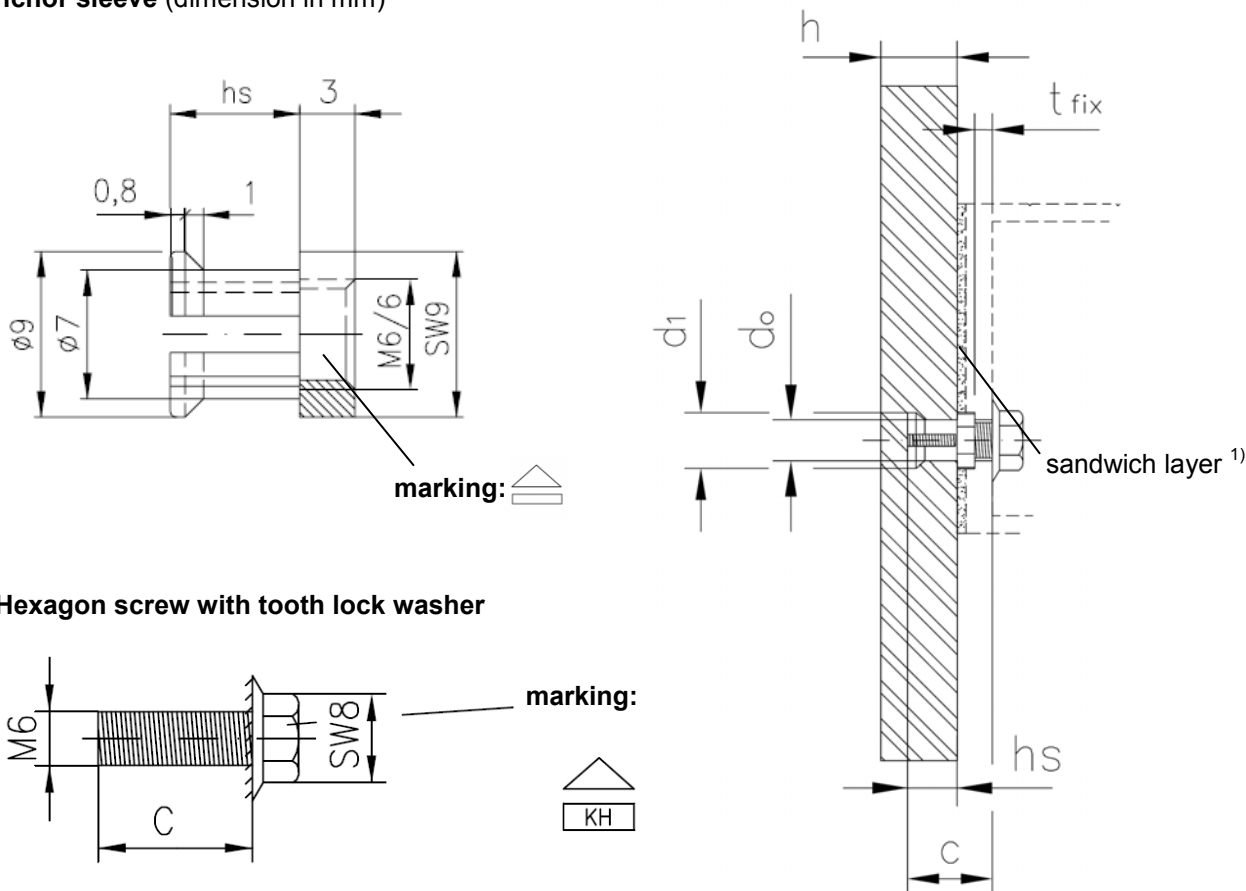

<sup>1)</sup> elastic sandwich layer (e.g. EPDM) - thickness 1.0 to 3.0 mm

**Table A1: Dimensions and Materials**

Anchor type		KH 5,5	KH 7,0	KH 8,5
anchorage depth	$h_s =$ [mm]	5,5	7,0	8,5
panel thickness	$h \geq$ [mm]	8,0	9,5	11,0
diameter of drill hole	$d_o =$ [mm]	7,0		
Diameter of undercut	$d_1 =$ [mm]	9,0		
screw length	$c =$ [mm]	$h_s + 3\text{mm} + t_{\text{fix}}$		
installation torque moment	$T_{\text{inst}}$ [Nm]	$2,5 \leq T_{\text{inst}} \leq 4,0$		
Materials		KH 5,5	KH 7,0	KH 8,5
anchor sleeve		Stainless steel 1.4404 according to EN 10 088:2014		
hexagon screw with tooth lock washer		Stainless steel 1.4401, 1.4404 or 1.4578 according to EN 10 088:2014		

KEIL undercut anchor KH for porcelain stoneware "Casalgrande Padana"

**Product description**  
Dimensions and Materials

Annex A 2

## Specifications of intended use

### Anchorage subject to:

- Static and quasi-static loads.

### Base materials:

- the "Casalgrande Padana" porcelain stoneware façade panels shall correspond to the group AI<sub>a</sub>, AI<sub>b</sub>, BI<sub>a</sub> or BI<sub>b</sub> according to EN 14411:2012 and to the specifications given in Annex B 6.

### Use conditions (Environmental conditions):

- Structures subject to dry internal conditions.
- Structures subject to external atmospheric exposure (including industrial and marine environment) and to permanently damp internal condition, if no particular aggressive conditions exist.

Note: Particular aggressive conditions are e.g. permanent, alternating immersion in seawater or the splash zone of seawater, chloride atmosphere of indoor swimming pools or atmosphere with extreme chemical pollution (e.g. in desulphurization plants or road tunnels where de-icing materials are used).

### Design:

- The design of the façade panels and their fixing is carried out according to the conditions given in Annex B 2 to Annex B 5.

### Installation:

- During transport and storage on site the façade panels are protected from damages; the façade panels are not be hung up jerkily (if need be lifters shall be used for hanging up the façade panels); façade panels and reveal panels respectively with incipient cracks are not be installed.
- The drillings are done at the factory or on site under workshop conditions; when making the drillings on site the execution is supervised by the responsible project supervisor or a skilled representative of the project supervisor.
- Making of the undercut drilling is done with the drill bit according to Annex B 7 and a special drilling device in accordance with the information deposited with Deutsches Institut für Bautechnik.
- In case of aborted hole: new drilling at a minimum distance away of twice the depth of the aborted hole.
- the geometry of the drill hole is checked on 1 % of all drillings. The following dimensions shall be checked and documented according to manufacturer's information and testing instructions by means of a measuring device according to Annex B 7:
  - Volume of the undercut drill hole.
  - Depth position of the undercut; the distance between the lower edge of the measuring device and the façade panel is between 0,0 and 0,3 mm (see Annex B 7).

If the tolerances given in Annex A 2, Table A1 are exceeded, the geometry of the drill hole shall be checked on 25% of the drillings performed. No further drill hole may exceed the tolerances otherwise all the drill holes shall be controlled. Drilling holes falling below or exceeding the tolerances shall be rejected.

Note: Checking the geometry of the drill hole on 1 % of all drillings means that on one of the 25 panels (this corresponds to 100 drillings in façade panels with four anchors) one drilling shall be checked. If the tolerances given in Annex A 2, Table A1 are exceeded the extent of the control shall be increase to 25 % of the drillings, i.e. one drilling each shall be checked on all the 25 panels.

- The façade are installed by skilled specialists and the laying instructions of the manufacturer shall be paid attention to.
- Between agraffe and façade panel an elastic sandwich layer may be placed. (see Annex A 1)

KEIL undercut anchor KH for porcelain stoneware "Casalgrande Padana"

**Intended use**  
Specifications

Annex B 1

## Design method

### General

The design values of the actions shall be calculated on basis of EN 1990 in consideration of the existing loads. The combinations of actions shall be equal to EN 1990. The actions shall be specified according to EN 1991-1-1 to EN 1991-1-7. Corresponding national regulations shall be taken into consideration. The unfavourable combination is decisive. Where necessary for the design of the anchor and the façade panel several combinations shall be analysed separately.

The typical fundamental combination for façade panels considers actions from dead load  $F_{Sk,G}$  (permanent action) and wind  $F_{Sk,w}$  (leading variable action).

According to EN 1990 the following fundamental combination depending on the load direction results for a vertical façade panel:

Fundamental combination for loads parallel to the panel:

$$F_{Sd||} = F_{Sk,G} \cdot \gamma_G$$

Fundamental combination for loads perpendicular to the panel:

$$F_{Sd\perp} = F_{Sk,w} \cdot \gamma_Q + F_{Sk,Zw} \cdot \gamma_G$$

$$\text{with } \gamma_G = 1,35; \gamma_Q = 1,50$$

For hanging panels (over head mounting) or reveals respectively the load direction shall be taken into consideration and the combinations of actions shall be based on EN 1990.

The calculation shall be carried out in a linear elastic manner. The stiffness of the substructure shall be considered for the respective case of application.

- Each façade panel is fixed with at least four anchors in a rectangular arrangement via single agraffes on the substructure (for small panels or small fitted pieces, differential or fill- in pieces the number and position of the anchors shall be chosen constructively).
- The façade panels are aranged in a "reclined" or "uprighth" position, they also may be fixed at façade soffits.
- The substructure is constructed such that the façade panels are fixed according to Annex B 8 technically strain-free via skids (loose bearings) and one fixed point (fixed bearing) - the fixed point may be placed at the panel edge or in the panel field - and that there are no additional loads acting on the panels and their fixings due to excentric load application / laod transfer (symmetrical bearing of the panels).
- Two fixing points of the façade panel are designed such that they are able to carry the dead load of the façade panel.
- When using agraffes on horizontal load-bearing profiles the fixing points of a façade panel situated horizontally at the same height are fastened in each case to the same load-bearing profile.
- Joint construction between the façade panels is done by a joint filler or are kept open; it is ensured that additional stresses (e.g. by temperature) do not lead to important additional loadings.
- Verifiable calculation notes and drawings shall be prepared taking account of the loads to be anchored, the nature and strength of the base materials and the dimensions of the anchorage members as well as of the relevant tolerances. The position of the anchor is indicated on the design drawings.
- The façade panels, their fixings as well as the substructure including its connection to wall brackets and their connection to the construction works are designed for the respective case of application under the responsibility of an engineer skilled in the field of façade construction.

KEIL undercut anchor KH for porcelain stoneware "Casalgrande Padana"

**Intended use**  
Design method

Annex B 2



**Guideline for structural calculation by means of FE - method**

For structural calculation by means of the Finite-Element-Method the façade panels are to be idealized with their effective dimensions (size and thickness) as panel elements; the system chosen shall have the capacity to sufficiently precise represent the tension and the deformation state as well as the support reactions of the façade panels. The mesh size at fixing range shall not exceed 10 mm.

The modelling of the façade panel is to be calibrated on the basis of the following points:

- modelling a panel section of 580 mm x 300 mm with a panel thickness of 13,3 mm
- support at the short sides with rotatable restraint
- loading at centre with a single load of 1,33 kN
- determination of a factor  $f_{cal,FE} = 41,8 / \sigma_{FE}$
- the determined bending stresses shall be multiplied with factor  $f_{cal,FE}$  ( $\sigma_{Sk} = \sigma_{FE} \cdot f_{cal,FE}$ ); the factor  $f_{cal,FE}$  shall only be considered for stresses due to support moments

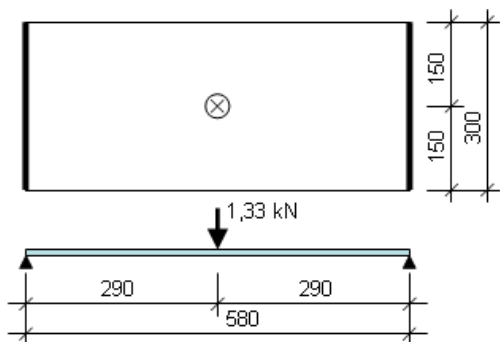

$\sigma_{FE}$  = maximum main tensile stress [N/mm<sup>2</sup>]

KEIL undercut anchor KH for porcelain stoneware "Casalgrande Padana"	Annex B 3
<b>Intended use</b> Design method	

**Verification of the anchor loads**

In addition to the actions from dead load and wind load the following actions shall be considered as permanent loads in direction to the anchor axes:

- due to mounting restraint a load  $N_{Sk,Zw} = 0,05 \text{ kN}$  shall be considered (in absence of no other national regulations)
- in case of flush fixing of the anchor and when using horizontal load-bearing profiles: due to torsion of the load-bearing profile resulting from dead load of the façade panel the following load  $N_{Sk,V}$  shall be considered:

$$N_{Sk,V} = V_{Sk} \cdot 2e/c_H$$

with  $V_{Sk}$  = shear load due to dead load of the façade panel;  $e$  und  $c_H$  [mm] (see Figure 2)

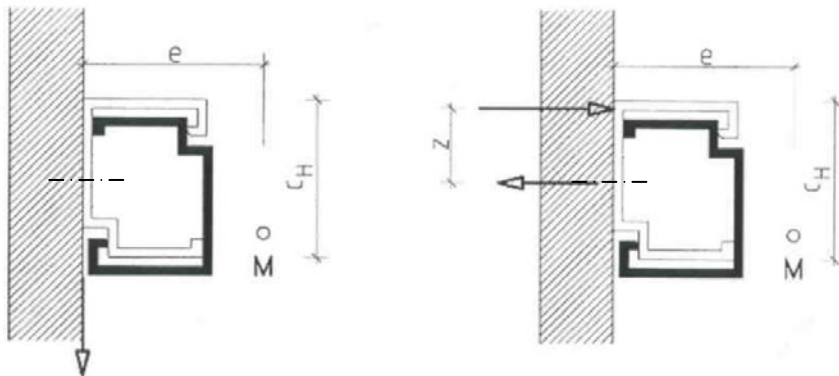

Figure 2: torsion of horizontal load-bearing profiles resulting from dead load of the façade panels

For the determined anchor forces it shall be verified, that the following equation are met:

Equation 1:  $\frac{N_{Sd}}{N_{Rd}} \leq 1$

Equation 2:  $\frac{V_{Sd}}{V_{Rd}} \leq 1$

Equation 3:  $\frac{N_{Sd}}{N_{Rd}} + \frac{V_{Sd}}{V_{Rd}} \leq 1$

With:

$N_{Sd}$  = design value of existing anchor tension load

$V_{Sd}$  = design value of existing anchor shear load

$N_{Rd}$  = design value of anchor load-bearing capacity for tension load:  $N_{Rd} = N_{Rk} / \gamma_M$  (with  $N_{Rk}$  and  $\gamma_M$  according to Annex C 1)

$V_{Rd}$  = design value of anchor load-bearing capacity for shear load:  $V_{Rd} = V_{Rk} / \gamma_M$  (with  $V_{Rk}$  and  $\gamma_M$  according to Annex C 1)

KEIL undercut anchor KH for porcelain stoneware "Casalgrande Padana"

**Intended use**  
Design method

Annex B 4

### Verification of the bending stresses

For the determined bending stresses it shall be verified, that the following equation is met:

Equation 4:  $\sigma_{Sd} \leq \sigma_{Rd}$

With

$\sigma_{Sd}$  = design value of existing bending stress in the façade panel

$\sigma_{Rd}$  = design value of bending strength:  $\sigma_{Rd} = \sigma_{Rk} / \gamma_M$  with  $\sigma_{Rk}$ ;  $\gamma_M$  according to Annex C 1, Table C1

In case of flush fixing of the anchor and when using horizontal load-bearing profiles: due to torsion of the load-bearing profile resulting from dead load of the façade panel the design value of the bending stress due to support moment shall be increased by the factor  $f_{cal,V}$  :

Equation 5: 
$$f_{cal,V} = \frac{N_{Sd,W} + N_{Sd,Zw} + N_{Sd,V}}{N_{Sd,W} + N_{Sd,Zw}}$$

With:

$N_{Sd,W}$  = design value of the existing anchor tension load due to wind load

$N_{Sd,Zw}$  = design value of the existing anchor tension load due to mounting restraint

$N_{Sd,V}$  = design value of the existing anchor tension load due to shear load (see Annex B 4)

### Characteristic resistance to wind loads for selective panel sizes and bearing conditions

For the panel sizes and bearing conditions given in Table B1 depending on the strength class, panel thickness, setting depth and edge distance the verification of structural stability is deemed to be verified, if the following condition is met:

$W_{Sd} \leq W_{Rk} / \gamma_M$

With:

$W_{Sd}$  = design value of the existing wind load

$W_{Rk}$  = characteristic resistance to wind loads according to Table B1

$\gamma_M$  = partial safety factor according to Table B1

**Table B1: characteristic resistance  $w_{Rk}$  to wind loads for selective panel sizes and bearing conditions depending on property class, panel thickness, setting depth and edge distance**

Klasse	d	h <sub>s</sub>	a <sub>rx</sub>	a <sub>ry</sub>	panel sizes	bearing condition <sup>1)</sup>	W <sub>Rk</sub>	γ <sub>M</sub>
[-]	[mm]	[mm]	[mm]	[mm]	[mm]	[-]	[kN/m <sup>2</sup> ]	[-]
B	≥ 11,5	≥ 7	60-120	100-200	600 × 1200	4 Agraffen	5,4	1,8
B	≥ 11,5	≥ 7	60-120	75-150	600 × 900	4 Agraffen	8,1	
B	≥ 9,5	≥ 7	60-120	60-120	600 × 600	4 Agraffen	10,8	
A	≥ 13	≥ 8,5	123	240-350	900 × 1200	4 Agraffen	2,2	
A	≥ 13	≥ 8,5	123	240-350	900 × 1200	6 Agraffen	2,7	
A	≥ 13	≥ 8,5	123	240-350	900 × 1200	8 Agraffen	4,3	
C	≥ 13	≥ 7	100	100	900 × 900	4 Agraffen	4,3	

<sup>1)</sup> maximum size of agraffe: width = 30 mm, height = 60 mm

KEIL undercut anchor KH for porcelain stoneware "Casalgrande Padana"

**Intended use**  
Design method

Annex B 5

**Requirements to "Casalgrande Padana" porcelain stoneware- façade panels**

Classification test (Initial type test)

The "Casalgrande Padana" porcelain stoneware façade panels shall be classified according to EN 14411:2012 "Ceramic tiles". The "Casalgrande Padana" porcelain stoneware façade panels shall correspond to the group Al<sub>a</sub>, Al<sub>b</sub>, Bl<sub>a</sub> or Bl<sub>b</sub> according to EN 14411:2012.

The following values shall be checked on at least 10 samples:

- bending strength - determined according to EN ISO 10545-4:2014-11 with the "visible face" on top; deviating from EN ISO 10 545-4:2014-11 the dimension of the test specimen is l/b = 400/200 mm and the support span is l<sub>s</sub> = 300 mm
- axial tension load – determined on test specimens with dimensions of l/b = 200/200 mm, an edge distance of 100 mm and a support diameter of ∅ = 70 mm
- shear load – determined on test specimens with dimensions of l/b = 400/200 mm and an edge distance of 100 mm

Acceptance Test (Verification of constancy of performance)

For each construction project the following values shall be checked on at least 10 samples independent of the scope of delivery:

- axial tension load – determined on test specimens with dimensions of l/b = 200/200 mm, an edge distance of 100 mm and a support diameter of ∅ = 70 mm

From the test results (Classification and Acceptance tests) the 5%-Fractile (confidence level of 75%, unknown standard deviation and lognormal distribution) shall be determined.

With the determined values of the 5%-Fractile the façade panels are to be classified according to the respective property class corresponding to Table B2.

**Table B2: characteristic values of façade panels –mechanical properties**

strength class of façade panels		A	B	C
Bending strength ("visible face" on top)	$\sigma_{u5\%} \geq$ [N/mm <sup>2</sup> ]	35	40	45
pull-out load tension load	$N_{u5\%} \geq$ [kN]	1,0	1,1	1,2
	$N_{u5\%} \geq$ [kN]	1,5	1,6	1,7
	$N_{u5\%} \geq$ [kN]	2,7	2,8	3,0
pull-out load shear load	$V_{u5\%} \geq$ [kN]	2,0	2,1	2,2
	$V_{u5\%} \geq$ [kN]	2,2	2,3	2,4
	$V_{u5\%} \geq$ [kN]	2,4	2,5	2,6

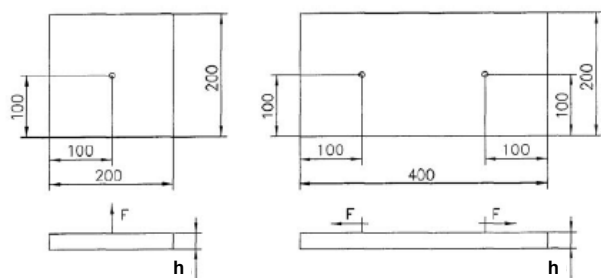
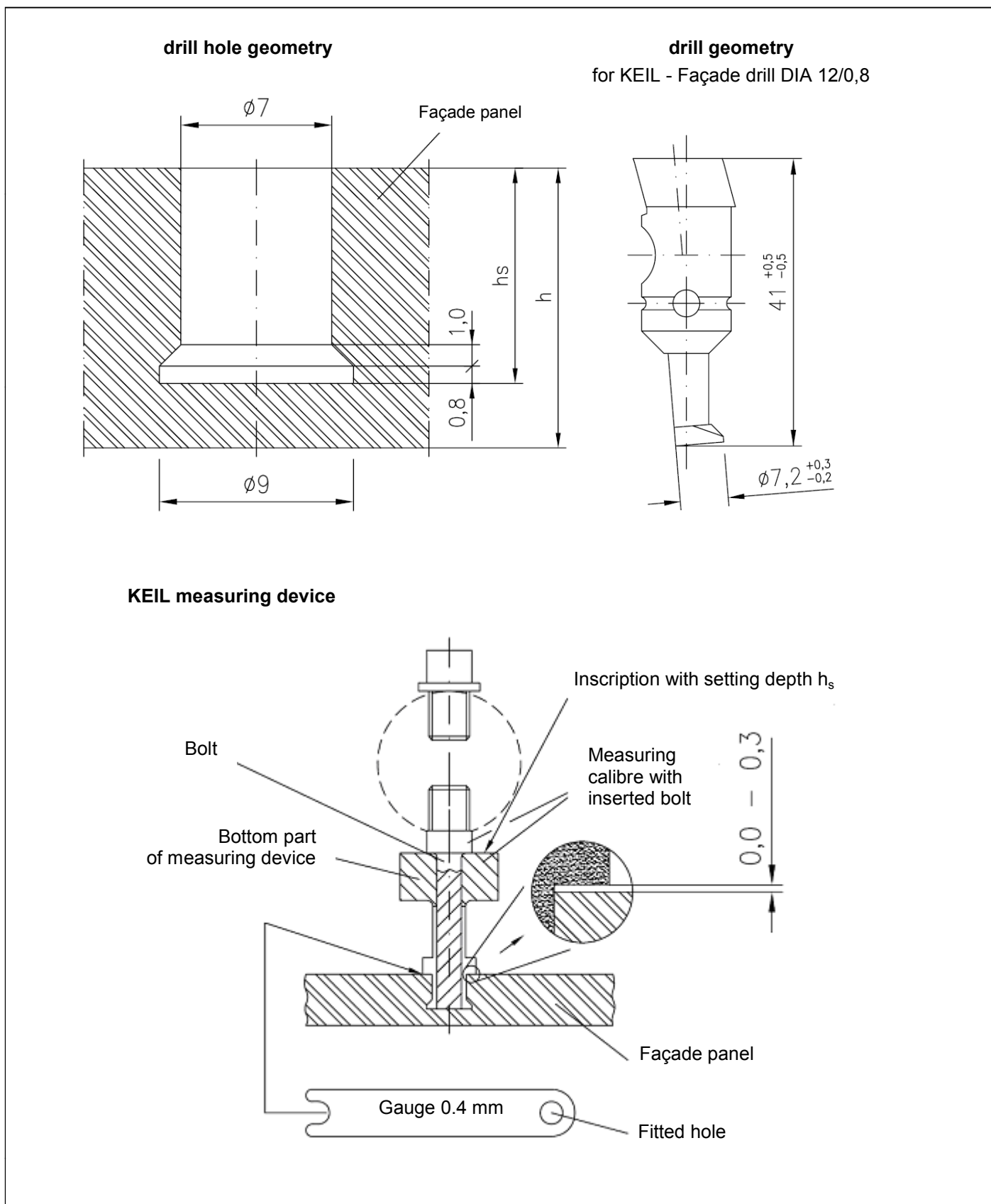

Figure 1: test specimen for tension test and shear test

KEIL undercut anchor KH for porcelain stoneware "Casalgrande Padana"	Annex B 6
<b>Intended use</b> Requirements to porcelain stoneware- façade panels	



Electronic copy of the ETA by DIBt: ETA-14/0470

KEIL undercut anchor KH for porcelain stoneware "Casalgrande Padana"

**Intended use**  
Drill hole dimensions  
Setting tools and testing equipment

Annex B 7

### Definition of edge distance and spacing

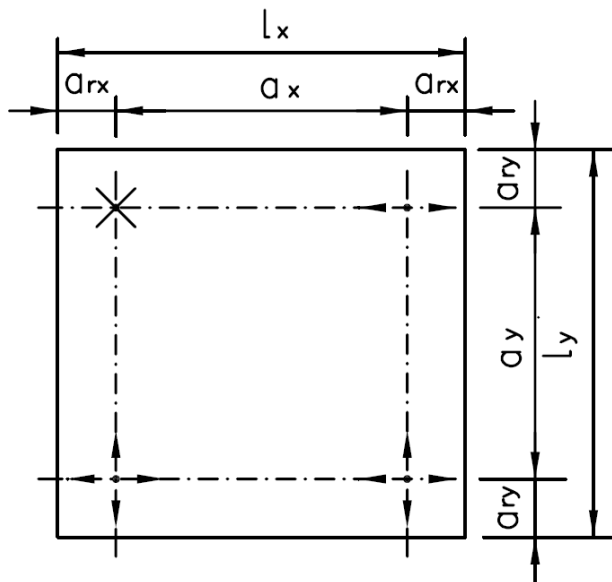

#### Legend:

- $a_{rx,y}$  = edge distance – distance of an anchor to the panel edge
- $a_{x,y}$  = spacing – distance between anchors
- $L_x$  = greater length of the façade panel
- $L_y$  = smaller length of the façade panel
- × = fixed point (fixed bearing)
- ⊕ = horizontal skid (loose bearing)
- ⊕⊕ = horizontal and vertical skid (loose bearing)

### Example for fixed point and loose bearing

fixed bearing (fixed point)

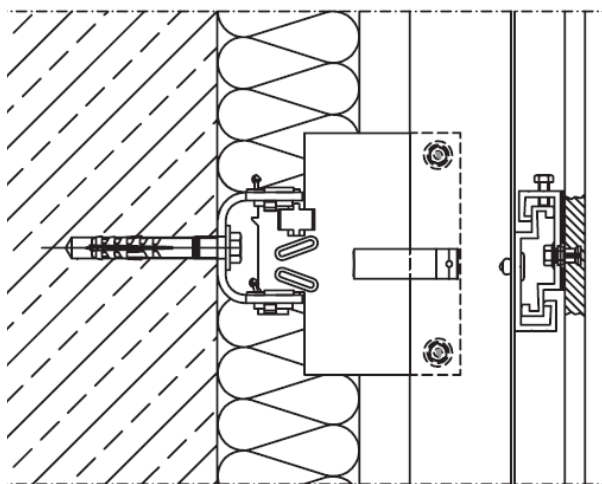

loose bearing (skid)

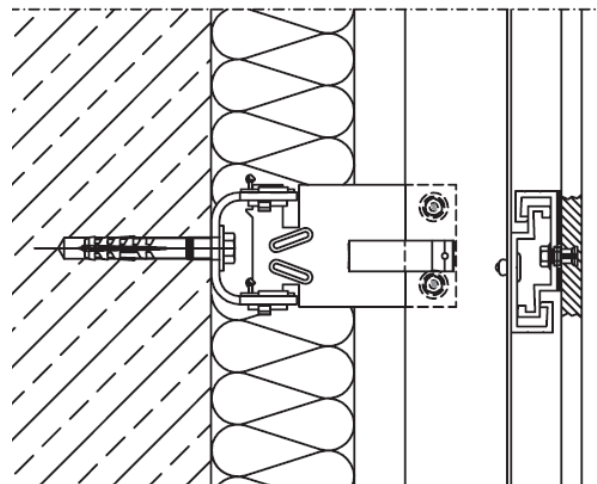

KEIL undercut anchor KH for porcelain stoneware "Casalgrande Padana"

#### Intended use

Definition of edge distance and spacing,  
Example for fixed point and loose bearing

Annex B 8

## Installation instructions

### 1. Drilling the undercut hole

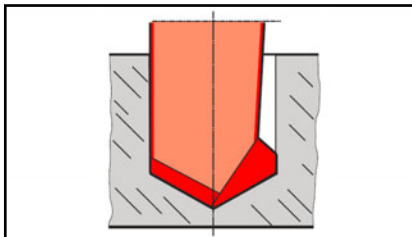

a) Cylindrical drilling

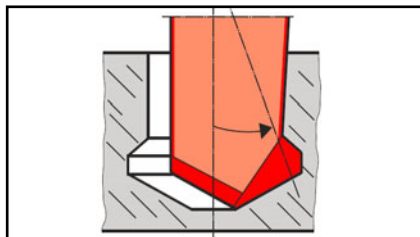

b) Undercutting

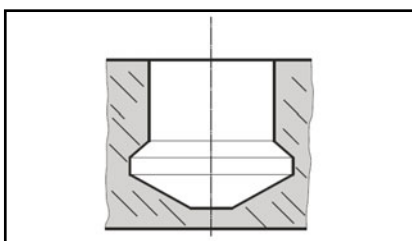

c) Finished undercut hole

### 2. Checking the undercut hole

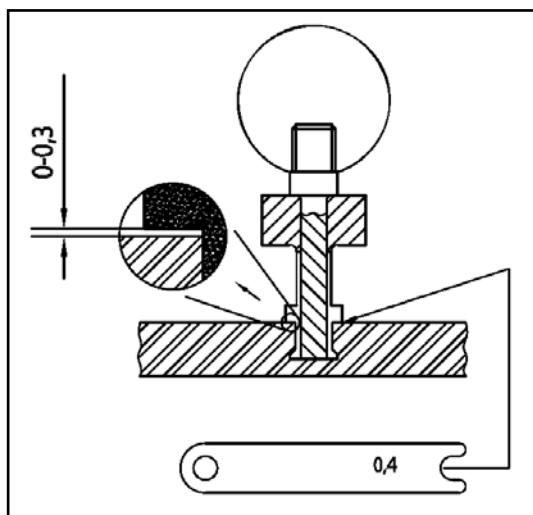

With KEIL depth control guide

KEIL undercut anchor KH for porcelain stoneware "Casalgrande Padana"

**Intended use**  
Installation instructions

Annex B 9

**3. Installation of anchor (sleeve and screw)**

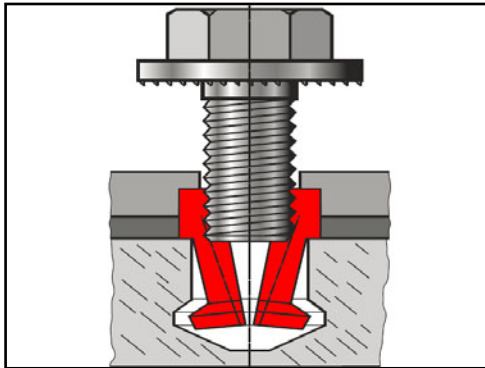

a) Insert the sleeve in the undercut hole and drill the screw in the sleeve

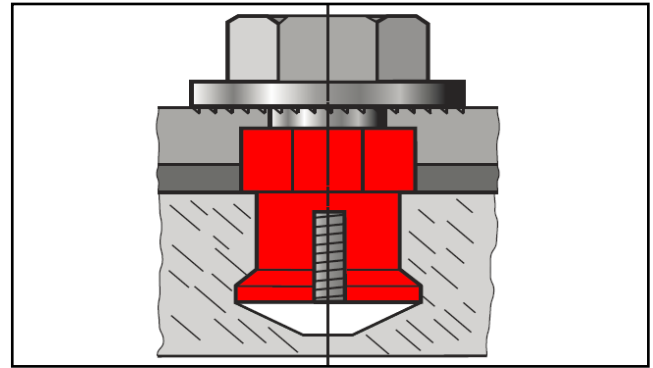

b) Installed anchor

**3. Installation of anchor (sleeve and grub screw)**

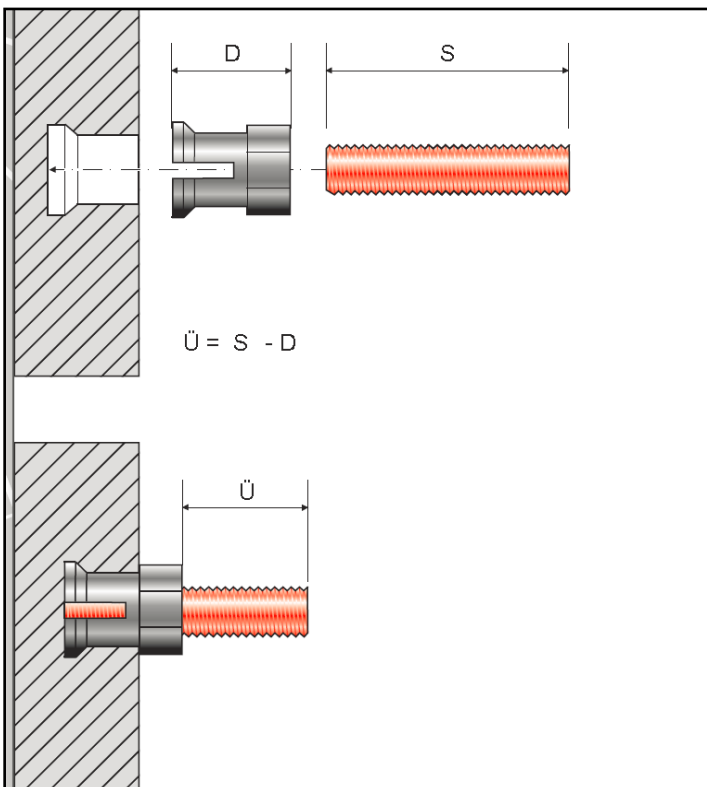

a) Insert the sleeve in the undercut hole

b) Drill the grub screw in the sleeve

c) Installed anchor

KEIL undercut anchor KH for porcelain stoneware "Casalgrande Padana"

**Intended use**  
Installation instructions

Annex B 10



Table C1: Characteristic values for the design of the anchor and façade panel

characteristic values of façade panel	strength class			Class A	Class B	Class C	
	char. resistance to bending stress	$\sigma_{Rk} =$	[N/mm <sup>2</sup> ]	35,0	40,0	45,0	
partial safety factor <sup>1)</sup>	$\gamma_M =$	[-]	1,8				
modulus of elasticity	$E =$	[N/mm <sup>2</sup> ]	30000				
poisson's ratio	$\nu =$	[-]	0,2				
specific weight	$\gamma =$	[kN/m <sup>3</sup> ]	25,0				
characteristic values of anchor	anchorage depth	$h_s =$	[mm]	5,5	7,0	8,5	
	panel thickness	$h \geq$	[mm]	8,0	9,5	11,0	
	Characteristic resistance to tension load <sup>2)</sup>	Class A	$N_{Rk} =$	[kN]	1,0	1,5	2,7
		Class B			1,1	1,6	2,8
		Class C			1,2	1,7	3,0
	characteristic resistance to shear load <sup>2)</sup>	Class A	$V_{Rk} =$	[kN]	2,0	2,2	2,4
		Class B			2,1	2,3	2,5
		Class C			2,2	2,4	2,6
	edge distance <sup>3) 4)</sup>	$a_r \geq$	[mm]	100			
	spacing	$a \geq$	[mm]	200			
partial safety factor <sup>1)</sup>	$\gamma_M =$	[-]	1,8				

<sup>1)</sup> In absence of other national regulations.

<sup>2)</sup> in case of coincident stress of an anchor due to tension and shear load the equation according to Annex B 4 shall be observed

<sup>3)</sup> The edge distance may be reduced to 50 mm. For edge distances  $50 \text{ mm} \leq a_r \leq 100 \text{ mm}$  the characteristic values of resistance for shear loads shall be reduced by the factor  $a_r/100$  [ $a_r$  in mm]; in case of different edge distances the smaller value is decisive

<sup>4)</sup> For small fitted pieces, differential and fill-in pieces the edge distance and spacing shall be chosen constructively

KEIL undercut anchor KH for porcelain stoneware "Casalgrande Padana"

**Performances**  
Characteristic values for the design of the anchor and façade panel

Annex C 1