

Approval body for construction products
and types of construction

Bautechnisches Prüfamt

An institution established by the Federal and
Laender Governments



European Technical Assessment

ETA-15/0027
of 30 January 2015

English translation prepared by DIBt - Original version in German language

General Part

Technical Assessment Body issuing the
European Technical Assessment:

Deutsches Institut für Bautechnik

Trade name of the construction product

SDF-S-14A and SDF-KB-14A

Product family
to which the construction product belongs

Plastic anchor for multiple use in concrete, masonry and
autoclaved aerated concrete for non-structural
applications

Manufacturer

EJOT Baubefestigungen GmbH
In der Stockwiese 35
57334 Bad Laasphe
DEUTSCHLAND

Manufacturing plant

EJOT Herstellwerk 1, 2, 3 und 4
manufacturing plant EJOT 1, 2, 3 und 4

This European Technical Assessment
contains

15 pages including 3 annexes which form an integral part
of this assessment

This European Technical Assessment is
issued in accordance with Regulation (EU)
No 305/2011, on the basis of

Guideline for European technical approval of "Plastic
Anchors for Multiple Use in Concrete and Masonry for
Non", ETAG 020 structural Applications - Part 1:
"General", Edition March 2012,
used as European Assessment Document (EAD)
according to Article 66 Paragraph 3 of Regulation (EU)
No 305/2011.

The European Technical Assessment is issued by the Technical Assessment Body in its official language. Translations of this European Technical Assessment in other languages shall fully correspond to the original issued document and shall be identified as such.

Communication of this European Technical Assessment, including transmission by electronic means, shall be in full. However, partial reproduction may only be made with the written consent of the issuing Technical Assessment Body. Any partial reproduction has to be identified as such.

This European Technical Assessment may be withdrawn by the issuing Technical Assessment Body, in particular pursuant to information by the Commission according to Article 25 Paragraph 3 of Regulation (EU) No 305/2011.

Specific Part

Technical description of the product

- 1** The EJOT frame fixing SDF-S-14A and SDF-KB-14A is a plastic anchor consisting of a plastic sleeve made of polyamide and an accompanying specific screw of galvanised steel with an additional coating or of stainless steel.
- The plastic sleeve is expanded by screwing in the specific screw which presses the sleeve against the wall of the drilled hole.
- The product description is given in Annex A.

2 **Specification of the intended use in accordance with the applicable European Assessment Document**

The performances given in Section 3 are only valid if the anchor is used in compliance with the specifications and conditions given in Annex B.

The verifications and assessment methods on which this European Technical Assessment is based lead to the assumption of a working life of the anchors of at least 50 years. The indications given on the working life cannot be interpreted as a guarantee given by the producer, but are to be regarded only as a means for choosing the right products in relation to the expected economically reasonable working life of the works.

3 **Performance of the product and references to the methods used for its assessment**

3.1 **Mechanical resistance and stability (BWR 1)**

The essential characteristics regarding mechanical resistance and stability are included under the Basic Works Requirement Safety in use.

3.2 **Safety in case of fire (BWR 2)**

Essential characteristic	Performance
Reaction to fire	Anchorage satisfy requirements for Class A 1
Resistance to fire	See Annex C

3.3 **Hygiene, health and the environment (BWR 3)**

Not applicable

3.4 **Safety and accessibility (BWR 4)**

Essential characteristic	Performance
Characteristic resistance for tension and shear loads	See Annex C
Characteristic resistance for bending moments	See Annex C
Displacements under shear and tension loads	See Annex C
Anchor distances and dimensions of members	See Annex B

English translation prepared by DIBt

3.5 Protection against noise (BWR 5)

Not applicable

3.6 Energy economy and heat retention (BWR 6)

Not applicable

3.7 Sustainable use of natural resources (BWR 7)

The sustainable use of natural resources was not investigated.

3.8 General aspects

The verification of durability is part of testing the essential characteristics. Durability is only ensured if the specifications of intended use according to Annex B are taken into account.

4 Assessment and verification of constancy of performance (AVCP) system applied, with reference to its legal base

According to Decision 97/463/EC of the Commission of 27 June 1997 (Official Journal of the European Communities L 198 of 25.07.1997, p. 31–32) the system of assessment and verification of constancy of performance (AVCP) (see Annex V and Article 65 Paragraph 2 to Regulation (EU) No 305/2011) given in the following table applies.

Product	Intended use	Level or class	System
Plastic anchors for use in concrete and masonry	For use in systems, such as façade systems, for fixing or supporting elements which contribute to the stability of the systems	—	2+

5 Technical details necessary for the implementation of the AVCP system, as provided for in the applicable European Assessment Document

Technical details necessary for the implementation of the AVCP system are laid down in the control plan deposited at Deutsches Institut für Bautechnik.

Issued in Berlin on 30 January 2015 by Deutsches Institut für Bautechnik

Andreas Kummerow
p. p. Head of Department

beglaubigt:
Ziegler

EJOT SDF-14A

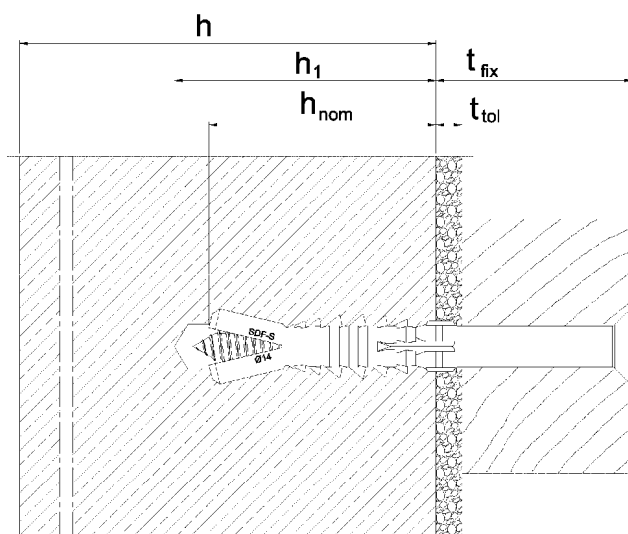

Intended use: screw head-type: countersunk (S)

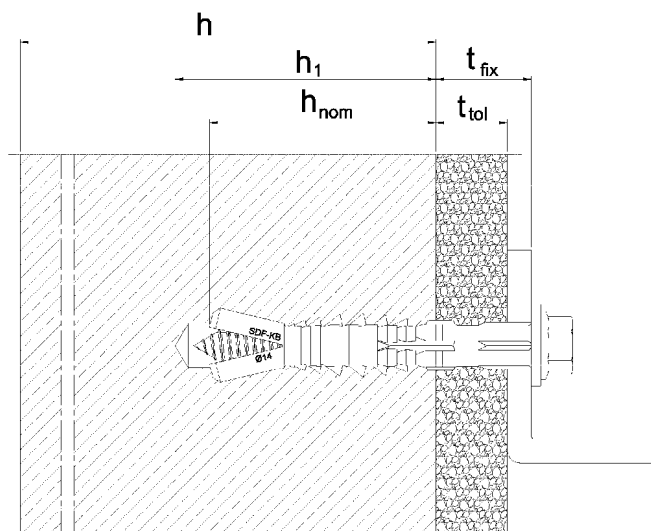

Intended use: screw head-type: hexagon head with collar (KB)

Legend

- h = Thickness of member
- h_1 = Depth of drilled hole to deepest point
- h_{nom} = Overall plastic anchor embedment depth in base material
- t_{tol} = Thickness of equalizing layer or non-load bearing coating
- t_{fix} = t_{tol} + Thickness of fixture

SDF-S-14A and SDF-KB-14A

Product description
Installed anchor

Annex A 1

Anchor sleeve

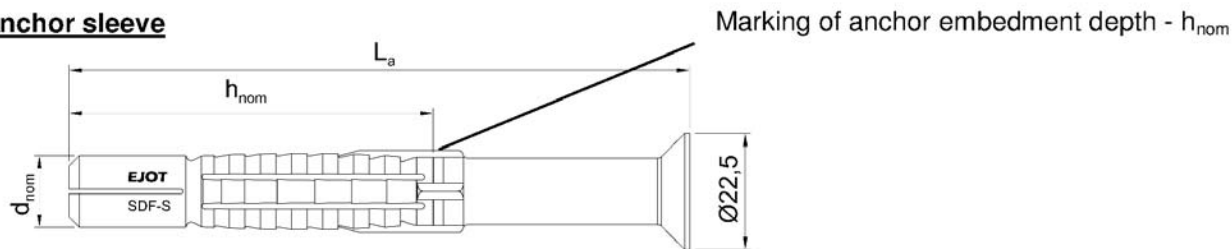

Special screw

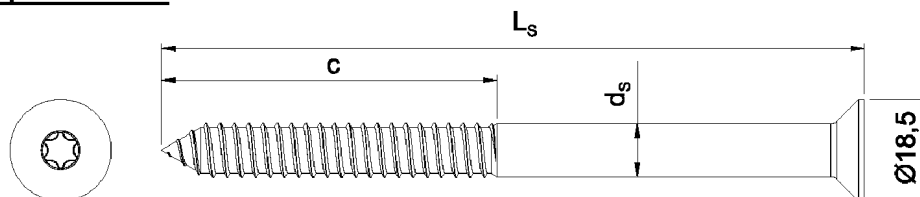

Type of anchor: countersunk (S)

Anchor marking:

manufacturer, anchor type incl. head type, diameter, length (at the anchor tip)

example: EJOT SDF-S-14A x 100

Screw marking:

length of anchor (e.g. 100)

Anchor sleeve

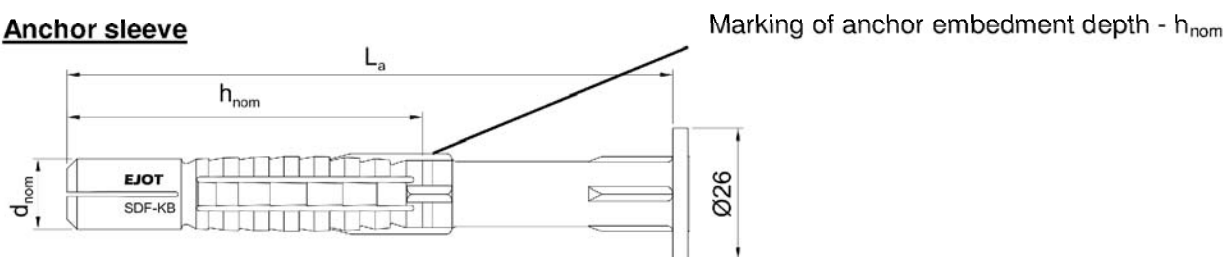

Special screw

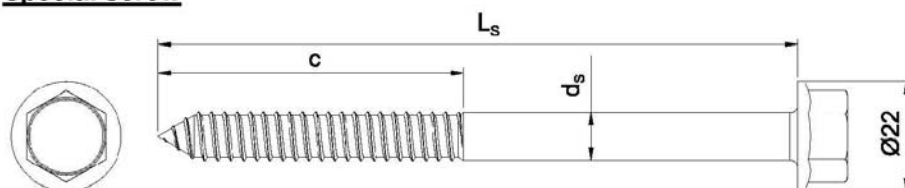

Type of anchor: collar with flange (KB)

Marking of the anchor:

manufacturer, anchor type incl. head type, diameter, length (at the anchor tip)

example: EJOT SDF-KB-14A x 100

Marking of the screw:

length of anchor (e.g. 100)

SDF-S-14A and SDF-KB-14A

Product description
Anchor types / specific screw

Annex A 2

Example of product identification

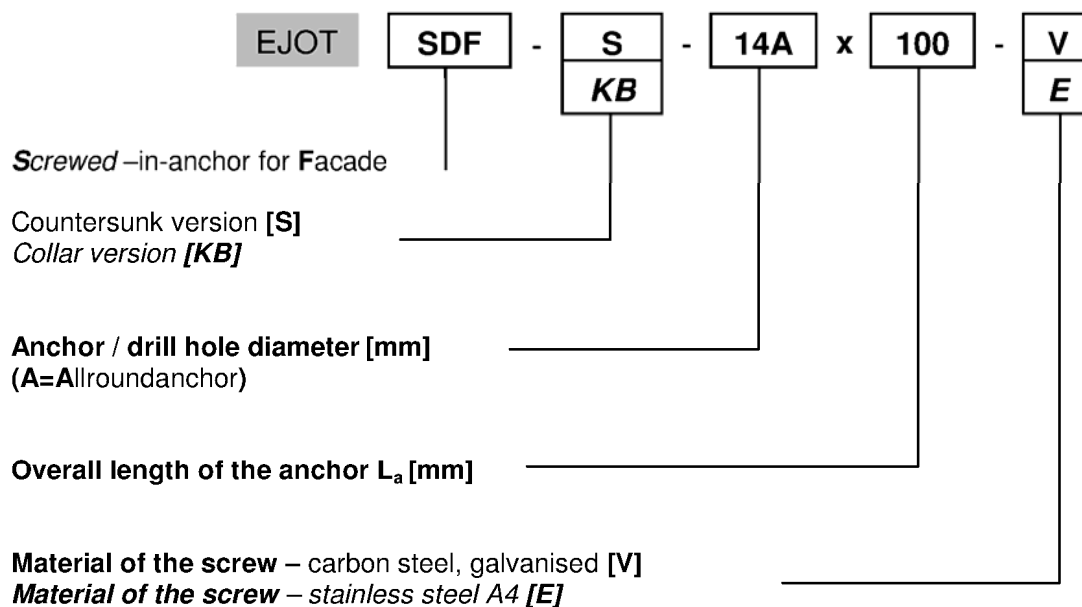

Table A3.1: Dimensions [mm]

Anchor type	Anchor sleeve					Specific screw		
	colour	d_{nom}	h_{nom}	min L_a	max L_a	L_s	d_s	c
SDF – KB - $\phi 14$	red	14	70	80	220	$L_a + 8,0$	9.6	60
SDF – S - $\phi 14$	red	14	70	80	360	$L_a + 8,0$	9.6	60

Designations: Annex A 2

Table A3.2: Materials

Element	Material
Anchor sleeve	Polyamide PA6, colour red
Special screw	steel, galvanized zinc plated > 5 μm acc. EN ISO 4042:2001-01 strength class 6.8
	Stainless steel acc. EN 10088-3:2012 strength class \geq A4-70

SDF-S-14A and SDF-KB-14A

Product description
Dimensions and materials

Annex A 3

Specifications of intended use

Anchorage subject to:

- Static and quasi-static loads.
- Multiple fixing of non-structural applications

Base materials:

- Reinforced or unreinforced normal weight concrete with strength classes $\geq C12/15$ (use category a), according to EN 206-1:2000, Annex C 1.
- Solid brick masonry (use category b), according to Annex C 2.
Note: The characteristic resistance is also valid for larger brick sizes and larger compressive strength of the masonry unit.
- Hollow brick masonry (use category c), according to Annex C 2.
- Autoclaved aerated concrete (use category d), according to Annex C 3.
- Mortar strength class of the masonry $\geq M2,5$ at minimum according to EN 998-2:2010.
- For other base materials of the use categories a, b, c and d the characteristic resistance of the anchor may be determined by job site tests according to ETAG 020, Annex B Edition March 2012.

Temperature Range:

- c: -20°C to 50°C (max. short term temperature $+50^{\circ}\text{C}$ and max long term temperature $+30^{\circ}\text{C}$)
- b: -20°C to 80°C (max. short term temperature $+80^{\circ}\text{C}$ and max long term temperature $+50^{\circ}\text{C}$)

Use conditions (Environmental conditions):

- Structures subject to dry internal conditions (zinc coated steel, stainless steel).
- The specific screw made of galvanised steel or galvanised steel may also be used in structures subject to external atmospheric exposure, if the area of the head of the screw is protected against moisture and driving rain after mounting of the fixing unit in this way, that intrusion of moisture into the anchor shaft is prevented. Therefore there shall be an external cladding or a ventilated rainscreen mounted in front of the head of the screw and the head of the screw itself shall be coated with a soft plastic, permanently elastic bitumen-oil-combination coating (e. g. undercoating or body cavity protection for cars).
- Structures subject to external atmospheric exposure (including industrial and marine environment and to permanently damp internal condition, if no particular aggressive conditions exist (stainless steel).
Note: Particular aggressive conditions are e.g. permanent, alternating immersion in seawater or the splash zone of seawater, chloride atmosphere of indoor swimming pools or atmosphere with extreme chemical pollution (e.g. in desulphurization plants or road tunnels where de-icing materials are used).

Design:

- The anchorages are designed in accordance with the ETAG 020, Annex C Edition March 2012 under the responsibility of an engineer experienced in anchorages and masonry work.
- Verifiable calculation notes and drawings shall be prepared taking account of the loads to be anchored, the nature and strength of the base materials and the dimensions of the anchorage members as well as of the relevant tolerances. The position of the anchor is indicated on the design drawings
- Fasteners are only to be used for multiple use for non-structural application, according to ETAG 020 Edition March 2012.

Installation:

- Hole drilling by the drill modes according to Annex C 1, C 2 and C 3 for use category a, b,c and d.
- Anchor installation carried out by appropriately qualified personnel and under the supervision of the person responsible for technical matters of the site.
- Installation temperature from -20°C to $+40^{\circ}\text{C}$
- Exposure to UV due to solar radiation of the anchor not protected ≤ 6 weeks

SDF-S-14A and SDF-KB-14A

Intended Use
Specifications

Annex B 1

Table B2.1: Installation parameters

Anchor type		SDF-KB-14A SDF-S-14A
Use categorie		a,b,c,d
Drill hole diameter	d_0 [mm] =	14
Cutting diameter of drill bit	d_{cut} [mm] ≤	14.45
Depth of the drill hole to deepest point	h_1 [mm] ≥	85
Embedment depth of the anchor in the base material ¹⁾	h_{nom} [mm] ≥	70
Diameter of the clearance hole in the fixture	d_f [mm] ≤	15.4
Thickness of fixture	t_{fix} [mm] ≥	10
minimum temperature during installation process	[°C]	-20
Temperature range (c)	[°C]	30 - 50
Temperature range (b)	[°C]	50 - 80

¹⁾ If the embedment depth is higher than h_{nom} given in Table B2.1 (only for hollow and perforated masonry), job site tests have to be carried out according to ETAG 020, Annex B.

Table B2.2: Minimum thickness of member, edge distance and spacing in concrete

Compressive strength	h_{min} [mm]	$c_{cr,N}$ [mm]	a [mm]	c_{min} [mm]	s_{min} [mm]
≥ C12/15	130	140	135	140	110
≥ C16/20	130	100	120	100	80

Fixing points with a spacing $\leq a$ are considered as a group with max. characteristic resistance $N_{Rk,p}$ according to Table C1.3. For a spacing $> a$ the anchors are always considered as single anchors, each with a characteristic resistance $N_{Rk,p}$ according to Table C1.3.

- h_{min} = Minimum thickness of member
- $c_{cr,N}$ = Characteristic edge distance
- a = Characteristic spacing
- c_{min} = minimum edge distance
- s_{min} = minimum spacing

Scheme of distances and spacings in concrete

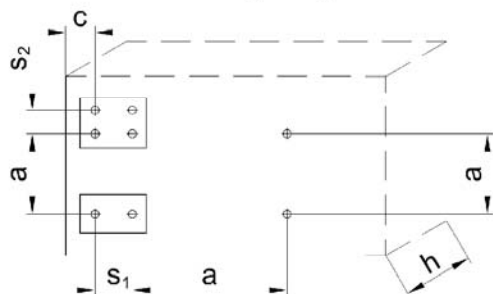

SDF-S-14A and SDF-KB-14A

Intended Use

Installation parameters, edge distances and spacings for use in concrete

Annex B 2

Table B3.1: Minimum distances and dimensions in masonry

Base Material	h_{min} [mm]	Single Anchor		Anchor Group			
		c_{min} [mm]	a [mm]	$c_{1,min}$ [mm]	$c_{2,min}$ [mm]	$s_{1,min}$ [mm]	$s_{2,min}$ [mm]
solid masonry							
771 1-001 Mz	115	120	250	120	150	120	120
771 2-009 KS	115	120	250	120	150	120	120
771 2-002 KS	240	125	250	125	150	120	120
771 3-006 V	175	120	250	120	150	120	120
hollow masonry							
771 1-002 Hlz	115	120	250	120	150	120	120
771 2-003 KSL	239	100	250	100	150	80	80
771 3-005 Hbl	175	100	250	100	150	80	250

Scheme of distances and spacings in masonry

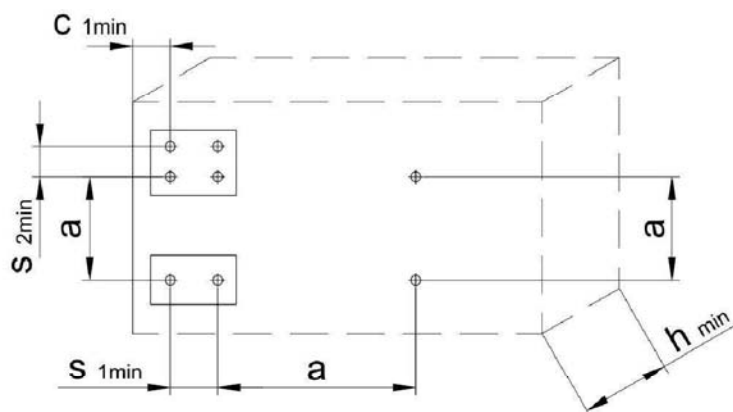

- h_{min} = Minimum thickness of member
- a = Characteristic spacing
- $c_{1,min}$ = minimum edge distance
- $c_{2,min}$ = minimum edge distance (perpendicular to c_1)
- $s_{1,min}$ = minimum spacing (perpendicular to free edge)
- $s_{2,min}$ = minimum spacing (parallel to free edge)

SDF-S-14A and SDF-KB-14A

Intended Use
Edge distances and spacings for use in masonry

Annex B 3

Table B4.1: Minimum distances and dimensions in autoclaved aerated concrete (AAC)

		AAC	$f_b \geq 2 \text{ N/mm}^2$ (AAC 2)	$f_b \geq 4 \text{ N/mm}^2$ (AAC 4)
Nominal embedment depth	h_{nom}	[mm]	70	70
Single anchor				
Minimum thickness of member	h_{min}	[mm]	175	300
Minimum edge distance	c_{min}	[mm]	100	100
Minimum spacing	a_{min}	[mm]	250	250
Anchor Group				
Minimum thickness of member	h_{min}	[mm]	300	300
Minimum edge distance	$c_{1,\text{min}}$	[mm]	100	120
Minimum edge distance (perpendicular to $c_{1,\text{min}}$)	$c_{2,\text{min}}$	[mm]	120	150
Minimum spacing perpendicular to free edge	$s_{1,\text{min}}$	[mm]	80	100
Minimum spacing parallel to free edge	$s_{2,\text{min}}$	[mm]	100	120

Scheme of spacings and edge distances

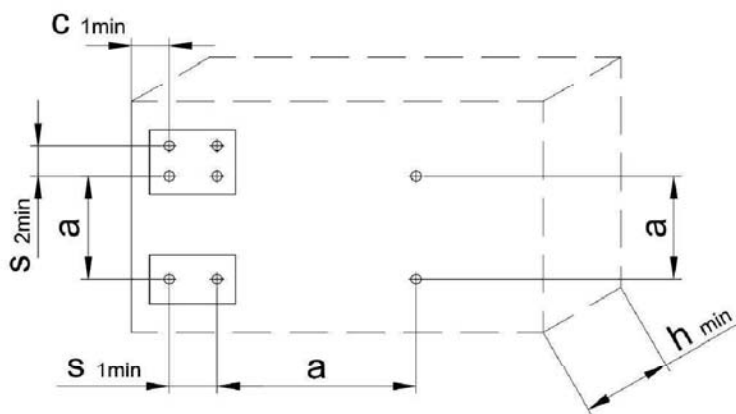

SDF-S-14A and SDF-KB-14A

Intended Use
Edge distances and spacings for use in autoclaved aerated concrete

Annex B 4

Installation instructions

(the following pictures show fixing through metal growing part exemplary)

1. Drill the bore hole \varnothing 14 mm using the drill method given in Annex C

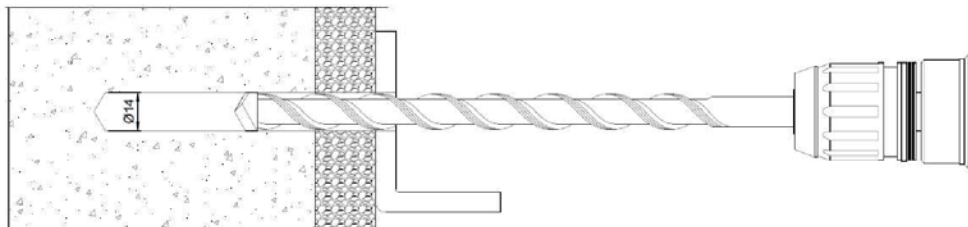

2. Clean the bore hole.
Insert assembly group of anchor (screw and sleeve) using a hammer, until the plastic sleeve is flush with surface of fixture

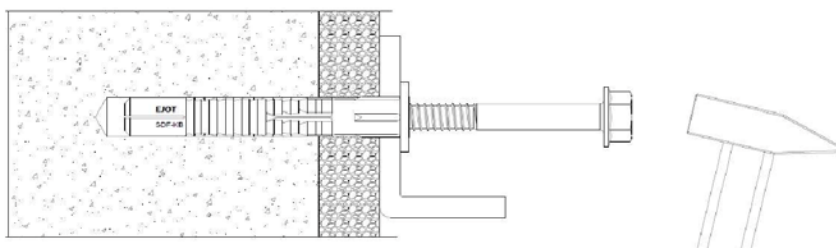

3. The screw is screwed-in until the head of the screw touches the plastic sleeve.

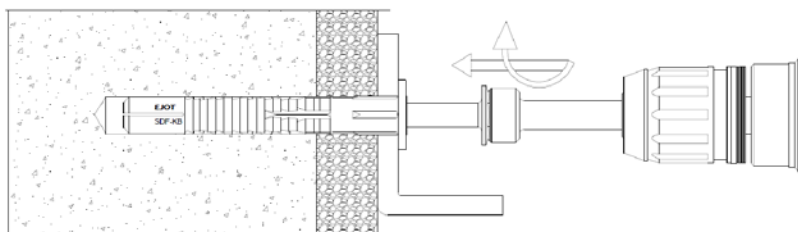

4. Correctly installed anchor

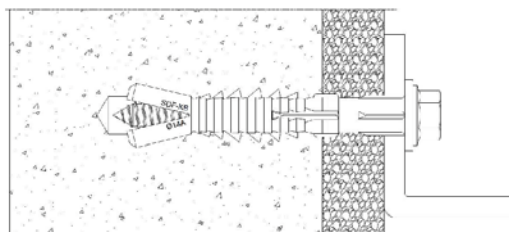

SDF-S-14A and SDF-KB-14A

Intended Use
Installation instructions

Annex B 5

Table C1.1: Characteristic resistance of the screw

Failure of expansion element (special screw)		SDF-14A	
Material		Galvanized steel	Stainless steel
Characteristic tension resistance	$N_{Rk,s}$ [kN]	43.3	50.7
Characteristic shear resistance	$V_{Rk,s}$ [kN]	21.7	25.3
Characteristic bending resistance	$M_{Rk,s}$ [Nm]	62.5	72.9

Table C1.2: Displacements¹⁾²⁾ under tension and shear loading in concrete, solid- and hollow masonry

Anchor Type	Tension or shear load	Displacements under tension load		Displacements under shear load	
		δ_{N0} [mm]	$\delta_{N\infty}$ [mm]	δ_{V0} [mm]	$\delta_{V\infty}$ [mm]
SDF-14A	F [kN]				
	3.4	0.71	0.84	2.42	3.63

¹⁾ Valid for all ranges of temperatures (b and c)

²⁾ Intermediate values by linear interpolation

Table C1.3: Characteristic resistance for use in concrete

Pull-out failure	Characteristic resistance
Concrete \geq C12/15	
Characteristic resistance	$N_{Rk,p}$ ¹⁾²⁾ [kN] 8.5

¹⁾ Valid for all ranges of temperatures (b and c)

²⁾ Drill hole with hammer drilling

Table C1.4: Characteristic values under fire exposure in concrete C 20/25 to C 50/60 in any load direction, no permanent centric tension load and without lever arm

Fire resistance class	F_{Rk}
R 90	≤ 0.8 kN

SDF-S-14A and SDF-KB-14A

Performances

Displacements under tension and shear loading in concrete and masonry
Characteristic resistance in concrete

Annex C 1

Table C2.1: Characteristic resistance F_{Rk} in solid and hollow masonry

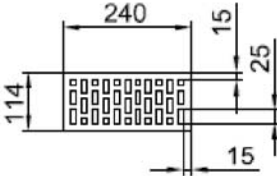
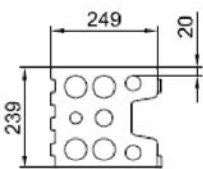
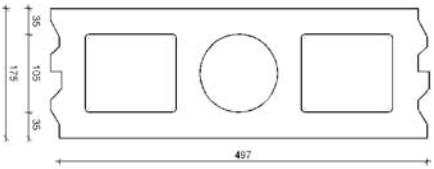
Base material	Size of stone [LxWxH] (min. Format)	Drilling method	min. Compressive strength f_b [N/mm ²]	c_{min} [mm]	F_{Rk} ²⁾ [kN]
Solid masonry					
Clay brick Mz 2DF 20-1.8 (EN 771-1:2011)	240x115x113	H ¹⁾	20	120	5.0 (5.5) ³⁾
			10		3.5
Calcium silicate solid brick KS 2DF 20-2.0 (EN 771-2:2011)	240x115x113	H ¹⁾	20	250	8.5 (12.0) ³⁾
			10		6.0 (9.0) ³⁾
			20	120	2.0
			10		1.5
Calcium silicate solid brick KS 8DF 20-1.8 (EN 771-2:2011)	249x240x238	H ¹⁾	20	125	7.0
			10		5.0
Lightweight solid brick V 3DF 8-1.2 (EN 771-3:2011)	240x175x113	H ¹⁾	8	120	3.0 (4.0) ³⁾
			6		2.0 (3.0) ³⁾
			4		1.5 (2.0) ³⁾
			2		0.75 (0.9) ³⁾
Hollow masonry					
Vertically perforated clay brick - Hlz 2DF 28-1.2 (EN 771-1:2011) (picture 1)	240x115x113	R ¹⁾	28	120	2.0
			20		1.5
			10		0.75 (0.9) ³⁾
Hollow calc. silicate brick KSL 8DF 16-1.4 (EN 771-2:2011) (picture 2)	249x239x238	H ¹⁾	20	100	2.5
			10		1.2
Hollow brick lightweight concrete - Hbl 12DF 4-1.2 (EN 771-3:2011) (picture 3)	490x175x239	R ¹⁾	6	100	2.5
			4		1.5
			2		0.9
Picture 1	Picture 2	Picture 3			
					

- 1) H = Hammerdrilling R = Rotary Drilling
- 2) Temperature range b and c
- 3) Valid only for temperature range c

SDF-S-14A and SDF-KB-14A

Performances

Characteristic resistance under tension and shear loading in masonry

Annex C 2

Table C3.1: Displacements¹⁾ under tension and shear loading in autoclaved aerated concrete (AAC)

SDF-14A	Tension or shear load	Displacements under tension load ²⁾		Displacements under shear load ²⁾	
		AAC EN 771-4	F [kN]	δ_{N0} [mm]	$\delta_{N\infty}$ [mm]
$f_b \geq 2 \text{ N/mm}^2$	0.43	0.35	0.70	0.86	1.29
$f_b \geq 3 \text{ N/mm}^2$	0.78	0.40	0.81	1.45	2.17
$f_b \geq 4 \text{ N/mm}^2$	1.02	0.46	0.93	2.04	3.06
$f_b \geq 5 \text{ N/mm}^2$	1.31	0.52	1.04	2.63	3.94
$f_b \geq 6 \text{ N/mm}^2$	1.61	0.58	1.16	3.22	4.83

¹⁾ Valid for all ranges of temperatures

²⁾ Intermediate values by linear interpolation

Table C3.2: Characteristic resistance F_{Rk} ²⁾ in autoclaved aerated concrete (AAC)

Autoclaved aerated concrete EN 771-4	Minimum compressive strength f_{ck} [N/mm ²]	F_{Rk} ¹⁾ [kN]	F_{Rk} ¹⁾ [kN]
		Temp. Range „c“ (30°C – 50°C)	Temp. Range „b“ (50°C – 80°C)
$f_b \geq 2 \text{ N/mm}^2$	2	1.2	0.9
$f_b \geq 3 \text{ N/mm}^2$	3	2.0	1.5
$f_b \geq 4 \text{ N/mm}^2$	4	2.5	2.5
$f_b \geq 5 \text{ N/mm}^2$	5	3.0	3.0
$f_b \geq 6 \text{ N/mm}^2$	6	3.5	3.5

¹⁾ Drill hole with hammer drilling

²⁾ Characteristic resistance for tension, shear or combined tension and shear loading.

SDF-S-14A and SDF-KB-14A

Performances

Displacements and characteristic resistance under tension and shear loading in autoclaved aerated concrete

Annex C 3