

Approval body for construction products
and types of construction

Bautechnisches Prüfamt

An institution established by the Federal and
Laender Governments



European Technical Assessment

ETA-15/0167
of 7 May 2015

English translation prepared by DIBt - Original version in German language

General Part

Technical Assessment Body issuing the
European Technical Assessment:

Deutsches Institut für Bautechnik

Trade name of the construction product

Ter Laare Wedge Anchor DX FAST ETA 1 and
DX-I FAST ETA 1

Product family
to which the construction product belongs

Torque controlled expansion anchor for use
in concrete

Manufacturer

TER LAARE VERANKERINGSTECHNIEKEN BV.
ZWARTE ZEE 20
3140 MAASSLUIS
NIEDERLANDE

Manufacturing plant

Ter Laare Verankeringsstechnieken BV
Herstellwerk 3

This European Technical Assessment
contains

32 pages including 3 annexes which form an integral part
of this assessment

This European Technical Assessment is
issued in accordance with Regulation (EU)
No 305/2011, on the basis of

Guideline for European technical approval of "Metal
anchors for use in concrete", ETAG 001 Part 2: "Torque
controlled expansion anchors", April 2013,
used as European Assessment Document (EAD)
according to Article 66 Paragraph 3 of Regulation (EU)
No 305/2011.

The European Technical Assessment is issued by the Technical Assessment Body in its official language. Translations of this European Technical Assessment in other languages shall fully correspond to the original issued document and shall be identified as such.

Communication of this European Technical Assessment, including transmission by electronic means, shall be in full. However, partial reproduction may only be made with the written consent of the issuing Technical Assessment Body. Any partial reproduction has to be identified as such.

This European Technical Assessment may be withdrawn by the issuing Technical Assessment Body, in particular pursuant to information by the Commission according to Article 25 Paragraph 3 of Regulation (EU) No 305/2011.

Specific Part

1 Technical description of the product

The Ter Laare Wedge anchor DX FAST ETA 1 and DX-I FAST ETA 1 is an anchor made of galvanised steel or made of stainless steel or high corrosion resistant steel which is placed into a drilled hole and anchored by torque-controlled expansion. The following anchor types are covered:

- Anchor type DX FAST ETA 1 with external thread, washer and hexagon nut, sizes M8 to M27,
- Anchor type DX-I FAST ETA 1 + DIN 933 with internal thread, hexagon head nut and washer DIN 933, sizes M6 to M12,
- Anchor type DX-I FAST ETA 1 + DIN 7991 with internal thread, countersunk head screw and countersunk washer DIN 7991, sizes M6 to M12,
- Anchor type DX-I FAST ETA 1 + DIN 976 with internal thread, hexagon nut and washer DIN 976, sizes M6 to M12.

The product description is given in Annex A.

2 Specification of the intended use in accordance with the applicable European Assessment Document

The performances given in Section 3 are only valid if the anchor is used in compliance with the specifications and conditions given in Annex B.

The verifications and assessment methods on which this European Technical Assessment is based lead to the assumption of a working life of the anchor of at least 50 years. The indications given on the working life cannot be interpreted as a guarantee given by the producer, but are to be regarded only as a means for choosing the right products in relation to the expected economically reasonable working life of the works.

3 Performance of the product and references to the methods used for its assessment

3.1 Mechanical resistance and stability (BWR 1)

| Essential characteristic | Performance |
|--|------------------------|
| Characteristic resistance for static and quasi static action for DX FAST ETA 1 | See Annex C 1 to C 5 |
| Characteristic resistance for seismic performance categories C1 and C2 for DX FAST ETA 1 | See Annex C 6 |
| Characteristic resistance for static and quasi static action for DX-I FAST ETA 1 | See Annex C 10 to C 12 |
| Displacements under tension loads for DX FAST ETA 1 | See Annex C 8 |
| Displacements under shear loads for DX FAST ETA 1 | See Annex C 9 |
| Displacements under tension and shear loads for DX-I FAST ETA 1 | See Annex C 14 |

English translation prepared by DIBt

3.2 Safety in case of fire (BWR 2)

| Essential characteristic | Performance |
|--|---|
| Reaction to fire | Anchorage satisfy requirements for Class A1 |
| Resistance to fire for DX FAST ETA 1 | See Annex C 7 |
| Resistance to fire for DX-I FAST ETA 1 | See Annex C 13 |

3.3 Hygiene, health and the environment (BWR 3)

Not applicable.

3.4 Safety in use (BWR 4)

The essential characteristics regarding Safety in use are included under the Basic Works Requirement Mechanical resistance and stability.

3.5 Protection against noise (BWR 5)

Not applicable.

3.6 Energy economy and heat retention (BWR 6)

Not applicable.

3.7 Sustainable use of natural resources (BWR 7)

The sustainable use of natural resources was not investigated.

3.8 General aspects

The verification of durability is part of testing the essential characteristics. Durability is only ensured if the specifications of intended use according to Annex B are taken into account.

4 Assessment and verification of constancy of performance (AVCP) system applied, with reference to its legal base

According to Decision of the Commission of 24 June 1996 (96/582/EC) (OJ L 254 of 08.10.96 p. 62-65), the system of assessment and verification of constancy of performance (see Annex V and Article 65 Paragraph 2 to Regulation (EU) No 305/2011) given in the following table applies.

| Product | Intended use | Level or class | System |
|---|--|----------------|--------|
| Metal anchors for use in concrete (heavy-duty type) | For fixing and/or supporting concrete structural elements or heavy units such as cladding and suspended ceilings | — | 1 |

5 Technical details necessary for the implementation of the AVCP system, as provided for in the applicable European Assessment Document

Technical details necessary for the implementation of the AVCP system are laid down in the control plan deposited at Deutsches Institut für Bautechnik.

Issued in Berlin on 7 May 2015 by Deutsches Institut für Bautechnik

Uwe Bender
Head of Department

beglaubigt:
Baderschneider

Wedge anchor DX FAST ETA 1

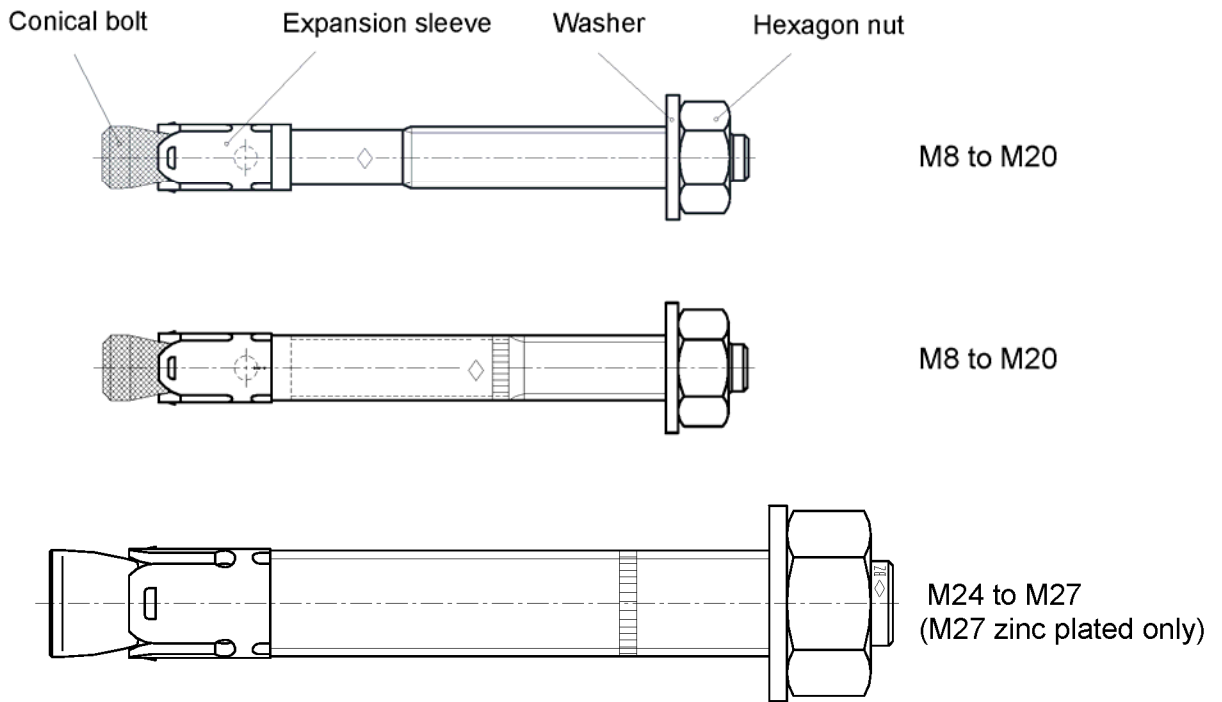

Wedge anchor **DX-I FAST ETA 1** M6 to M12

Anchor system

| | | | |
|---|------------------|--------------------|-------------------------|
| DX-I V FAST ETA 1 + DIN 933 | | Washer | Hexagon head screw |
| DX-I V FAST ETA 1 + DIN 7991 | Conical bolt | Countersunk washer | Countersunk head screw |
| DX-I V FAST ETA 1 + DIN 976 | Expansion sleeve | Washer Hexagon nut | Commercial standard rod |

| Anchor version | Product description | Intended use | Performance |
|------------------------|--|---------------------------------|-----------------------|
| DX FAST ETA 1 | Annex A1 – Annex A4 | Annex B1 – Annex B4 | Annex C1 – Annex C9 |
| DX-I FAST ETA 1 | Annex A1 – Annex A2 Annex A5 – Annex A6 | Annex B1 Annex B5 – Annex B7 | Annex C10 – Annex C14 |

| | |
|---|-----------------|
| Ter Laare Wedge Anchor DX FAST ETA 1 and DX-I FAST ETA 1 | Annex A1 |
| Product description Anchor types | |

Intended use Wedge Anchor DX FAST ETA 1

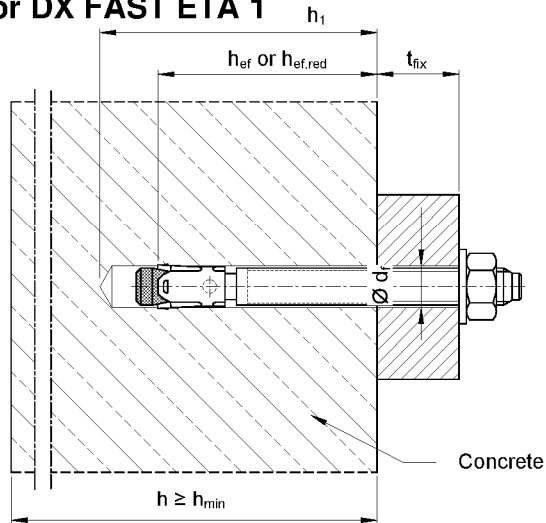

Intended use Wedge anchor DX-I FAST ETA 1

**Installation type V
pre-setting installation**

pre-set anchor body DX-I V FAST ETA 1, the fixture bears on the screw or thread rod only

DX-I V FAST ETA 1 + DIN 933

consisting of DX-I V FAST ETA 1 and DIN 933

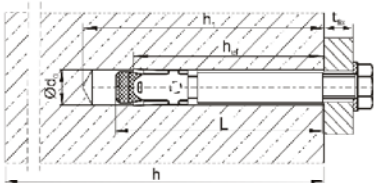

DX-I V FAST ETA 1 + DIN 7991

consisting of DX-I V FAST ETA 1 and DIN 7991

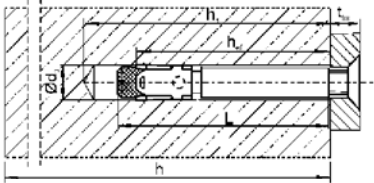

DX-I V FAST ETA 1 + DIN 976

consisting of DX-I V FAST ETA 1 and DIN 976

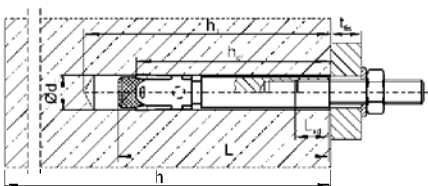

**Installation type D
through-setting installation**

the anchor is set through the fixture, the fixture bears on the conical bolt DX-I D FAST ETA 1

DX-I D FAST ETA 1 + DIN 933

consisting of DX-I D FAST ETA 1 and DIN 933

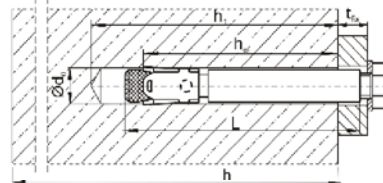

DX-I D FAST ETA 1 + DIN 7991

consisting of DX-I D FAST ETA 1 and DIN 7991

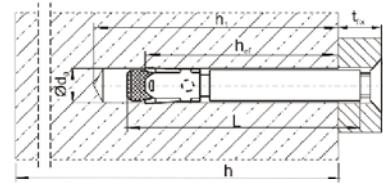

DX-I D FAST ETA 1 + DIN 976

consisting of DX-I D FAST ETA 1 and DIN 976

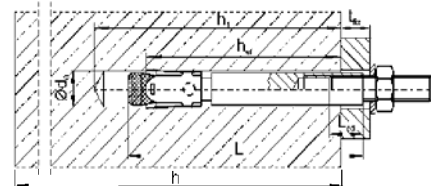

Ter Laare Wedge Anchor DX FAST ETA 1 and DX-I FAST ETA 1

Product description
Installation situation

Annex A2

Anchor size DX FAST ETA 1 M8 to M20:

Marking 1 e.g.: \diamond BZ 15/35

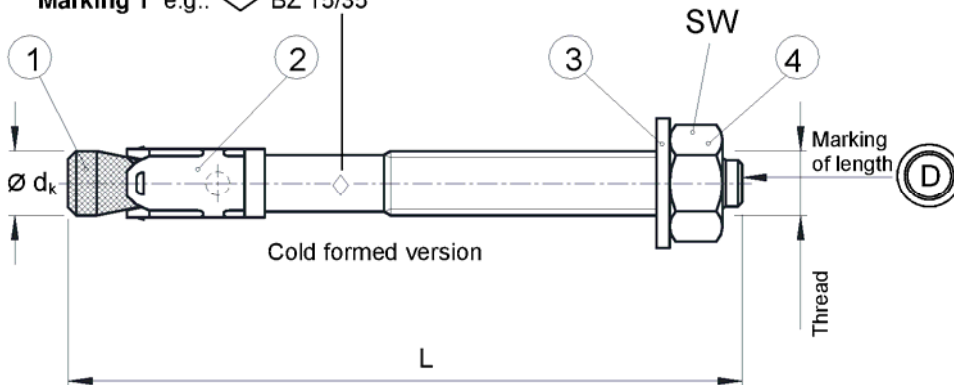

Marking 1: e.g.: \diamond BZ 15/35

- \diamond Identifying mark of manufacturing plant
- BZ Trade name
- 15 maximum thickness of fixture for h_{ef}
- 35 max. thickness of fixture for $h_{ef,red}$
- A4 additional marking of stainless steel A4
- HCR additional marking of high corrosion resistant steel HCR

Marking 2 e.g.: \diamond BZ 15

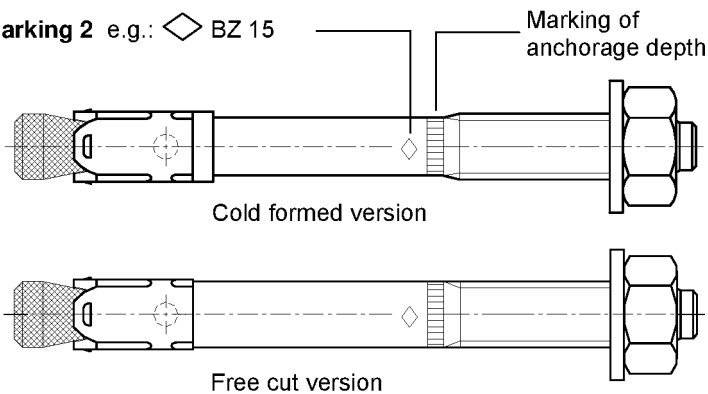

Marking 2: e.g.: \diamond BZ 15

- \diamond Identifying mark of manufacturing plant
- BZ Trade name
- 15 maximum thickness of fixture for h_{ef}
- A4 additional marking of stainless steel A4
- HCR additional marking of high corrosion resistant steel HCR

Anchor size DX FAST ETA 1 M24 and M27:

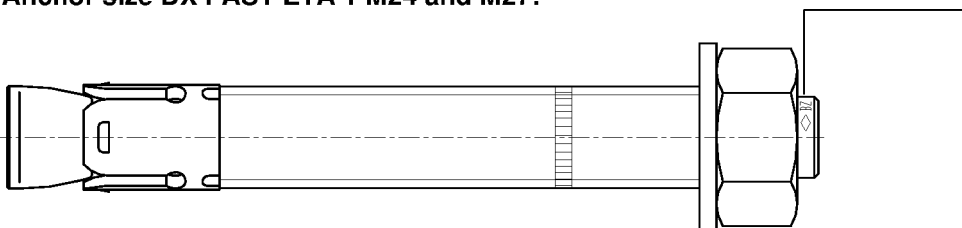

Marking 3: e.g.: \diamond BZ M24-30

- \diamond Identifying mark of manufacturing plant
- BZ Trade name
- M24 Thread diameter
- 30 maximum thickness of fixture
- A4 additional marking of stainless steel A4

| Marking of length | C (c) | D (d) | E (e) | F (f) | G (g) | H (h) | I (i) | J (j) | K (k) | L (l) | M (m) | N (n) |
|-----------------------------|-------|-------|-------|-------|-------|-------|-------|-------|-------|-------|-------|-------|
| Length of anchor min \geq | 63,5 | 76,2 | 88,9 | 101,6 | 114,3 | 127,0 | 139,7 | 152,4 | 165,1 | 177,8 | 190,5 | 203,2 |
| Length of anchor max $<$ | 76,2 | 88,9 | 101,6 | 114,3 | 127,0 | 139,7 | 152,4 | 165,1 | 177,8 | 190,5 | 203,2 | 215,9 |

| Marking of length | O (o) | P (p) | Q (q) | R (r) | S (s) | T (t) | U (u) | V (v) | W (w) | X (x) | Y (y) | Z (z) |
|-----------------------------|-------|-------|-------|-------|-------|-------|-------|-------|-------|-------|-------|-------|
| Length of anchor min \geq | 215,9 | 228,6 | 241,3 | 254,0 | 279,4 | 304,8 | 330,2 | 355,6 | 381,0 | 406,4 | 431,8 | 457,2 |
| Length of anchor max $<$ | 228,6 | 241,3 | 254,0 | 279,4 | 304,8 | 330,2 | 355,6 | 381,0 | 406,4 | 431,8 | 457,2 | 483,0 |

Ter Laare Wedge Anchor DX FAST ETA 1

Product description
Anchor sizes and marking

Annex A3

Table A1: Anchor dimensions DX FAST ETA 1

| Anchor size | | | M8 | M10 | M12 | M16 | M20 | M24 | M27 | |
|-------------|----------------------|---------------------|----------------|----------------|------------------|------------------|-----------------|-----------------|-----------------|-----------------|
| 1 | Conical bolt | Thread | M8 | M10 | M12 | M16 | M20 | M24 | M27 | |
| | | $\varnothing d_k =$ | 7,9 | 9,8 | 12,0 | 15,7 | 19,7 | 24 | 28 | |
| | Length of anchor | Steel, zinc plated | L | $65 + t_{fix}$ | $80 + t_{fix}$ | $96,5 + t_{fix}$ | $118 + t_{fix}$ | $137 + t_{fix}$ | $161 + t_{fix}$ | $178 + t_{fix}$ |
| | | A4, HCR | L | $65 + t_{fix}$ | $80 + t_{fix}$ | $96,5 + t_{fix}$ | $118 + t_{fix}$ | $137 + t_{fix}$ | $168 + t_{fix}$ | |
| | red. anchorage depth | $L_{hef,red}$ | $54 + t_{fix}$ | $60 + t_{fix}$ | $76,5 + t_{fix}$ | $98 + t_{fix}$ | | | | |
| 2 | Expansion sleeve | | see Table A2 | | | | | | | |
| 3 | Washer | | see Table A2 | | | | | | | |
| 4 | Hexagon nut | SW | 13 | 17 | 19 | 24 | 30 | 36 | 41 | |

Dimensions in mm

Table A2: Materials DX FAST ETA 1

| No. | Part | Steel, zinc plated M8 to M20 | Steel, zinc plated M24 and M27 | Stainless steel A4 | High corrosion resistant steel (HCR) |
|-----|------------------|---|--|---|--|
| 1 | Conical bolt | Cold formed or machined steel, Cone plastic coated (M8 to M20) | Threaded bolt and threaded cone, steel | Stainless steel 1.4401, 1.4404, 1.4571 or 1.4578, EN 10088:2005, Cone plastic coated | High corrosion resistant steel 1.4529 or 1.4565, EN 10088:2005, Cone plastic coated |
| 2 | Expansion sleeve | Steel acc. to EN 10088:2005, material No. 1.4301 or 1.4401 | Steel acc. to EN 10139-12:1997 | Stainless steel 1.4401 or 1.4571, EN 10088:2005 | Stainless steel 1.4401 or 1.4571, EN 10088:2005 |
| 3 | Washer | Steel, galvanised | | Stainless steel 1.4401 or 1.4571, EN 10088:2005 | High corrosion resistant steel 1.4529 or 1.4565, EN 10088:2005 |
| 4 | Hexagon nut | Steel, galvanised, coated | | stainless steel 1.4401 or 1.4571, EN 10088:2005, coated | high corrosion resistant steel 1.4529 or 1.4565, EN 10088:2005, coated |

Ter Laare Wedge Anchor DX FAST ETA 1

Product description
Dimensions and materials

Annex A4

Marking: \diamond Identifying mark of manufacturing plant
 BZ Trade name
 M6 Size of internal thread
 10 max. thickness of fixture
 (only installation type D)
 A4 additionally for stainless steel
 HCR additionally for high corrosion resistant
 steel

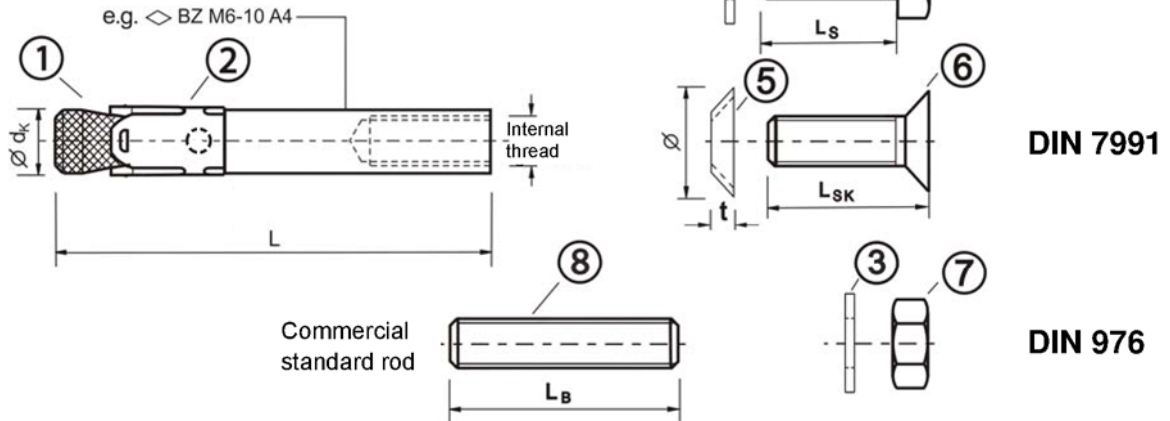

Table A3: Anchor dimensions DX-I FAST ETA 1

| No. | Anchor size | | M6 | M8 | M10 | M12 | |
|-----|--|---------------------------|-------------------------------|---|-------------------------------|-------------------------------|-----------------------|
| 1 | Conical bolt with Internal thread Installation type V Installation type D | $\varnothing d_k$ | 7,9 | 9,8 | 11,8 | 15,7 | |
| | | L | 50 | 62 | 70 | 86 | |
| | | L | 50 + t _{fix} | 62 + t _{fix} | 70 + t _{fix} | 86 + t _{fix} | |
| 2 | Expansion sleeve | see table A4 | | | | | |
| 3 | Washer | see table A4 | | | | | |
| 4 | Hexagon head screw Installation type V Installation type D | width across flats | 10 | 13 | 17 | 19 | |
| | | L _S | t _{fix} + (13 to 21) | t _{fix} + (17 to 23) | t _{fix} + (21 to 25) | t _{fix} + (24 to 29) | |
| | | L _S | 14 to 20 | 18 to 22 | 20 to 22 | 25 to 28 | |
| 5 | Countersunk washer | \varnothing countersink | 17,3 | 21,5 | 25,9 | 30,9 | |
| | | t | 3,9 | 5,0 | 5,7 | 6,7 | |
| 6 | Countersunk head screw | bit size | Torx T30 | Torx T45 (Steel, zinc plated) T40 (Stainless steel A4, HCR) | Hexagon socket 6 mm | Hexagon socket 8 mm | |
| | | L _{SK} | t _{fix} + (11 to 19) | t _{fix} + (15 to 21) | t _{fix} + (19 to 23) | t _{fix} + (21 to 27) | |
| | | L _{SK} | 16 to 20 | 20 to 25 | 25 | 30 | |
| 7 | Hexagon nut | width across flats | 10 | 13 | 17 | 19 | |
| 8 | Commercial standard rod ¹⁾ | type V | L _B ≥ | t _{fix} + 21 | t _{fix} + 28 | t _{fix} + 34 | t _{fix} + 41 |
| | | type D | L _B ≥ | 21 | 28 | 34 | 41 |

¹⁾ acc. to specifications (Table A4)

Dimensions in mm

Ter Laare Wedge Anchor DX-I FAST ETA 1

Product description
Anchor parts, marking and dimensions

Annex A5

Table A4: Materials **DX-I FAST ETA 1**

| No. | Part | Steel, zinc plated ≥ 5 µm acc. to EN ISO 4042:1999 | Stainless steel A4 | High corrosion resistant steel HCR |
|-----|---|---|---|---|
| 1 | Conical bolt DX-I FAST ETA 1 with internal thread | Machined steel, Cone plastic coated | Stainless steel, 1.4401, 1.4404, 1.4571, 1.4362, EN 10088:2005, Cone plastic coated | High corrosion resistant steel, 1.4529, 1.4565, EN 10088:2005, Cone plastic coated |
| 2 | Expansion sleeve DX-I FAST ETA 1 | Stainless steel, 1.4301, 1.4401, EN 10088:2005 | Stainless steel, 1.4401, 1.4571, EN 10088:2005 | Stainless steel, 1.4401, 1.4571, EN 10088:2005 |
| 3 | Washer DIN 125A | Steel, galvanised | Stainless steel, 1.4401, 1.4571, EN 10088:2005 | High corrosion resistant steel, 1.4529, 1.4565, EN 10088:2005 |
| 4 | Hexagon head screw DIN 933 | Steel, galvanised, coated | Stainless steel, 1.4401, 1.4571, EN 10088:2005, coated | High corrosion resistant steel, 1.4529, 1.4565, EN 10088:2005, coated |
| 5 | Countersunk washer DIN 7991 | Steel, galvanised | Stainless steel, 1.4401, 1.4404, 1.4571, EN 10088:2005, zinc plated, coated | High corrosion resistant steel, 1.4529, 1.4565, EN 10088:2005, zinc plated, coated |
| 6 | Countersunk head screw DIN 7991 | Steel, galvanised coated | Stainless steel, 1.4401, 1.4571, EN 10088:2005, coated | High corrosion resistant steel, 1.4529, 1.4565, EN 10088:2005, coated |
| 7 | Hexagon nut DIN 934 | Steel, galvanised coated | Stainless steel, 1.4401, 1.4571, EN 10088: 2005, coated | High corrosion resistant steel, 1.4529, 1.4565, EN 10088:2005, coated |
| 8 | Commercial standard rod | Property class 8.8, EN ISO 898-1:2013-05 A ₅ > 8 % ductile | Stainless steel, 1.4401, 1.4571, EN 10088:2005, property class 70, EN ISO 3506:2009 | High corrosion resistant steel, 1.4529, 1.4565, EN 10088:2005, property class 70, EN ISO 3506:2009 |

Ter Laare Wedge Anchor DX-I FAST ETA 1

Product description
Materials

Annex A6

Specifications of intended use

| Wedge Anchor DX FAST ETA 1 | M8 | M10 | M12 | M16 | M20 | M24 | M27 |
|---|----|-----|-----|-----|-----|-----|-----|
| Static or quasi-static action | | | | ✓ | | | |
| Seismic action (Categorie C1 + C2) ^{1) 2)} | | ✓ | ✓ | ✓ | ✓ | | |
| Reduced anchorage depth ²⁾ | ✓ | ✓ | ✓ | ✓ | | | |
| Fire exposure ¹⁾ | | | | ✓ | | | |
| Cracked and non-cracked | | | | ✓ | | | |

| Wedge Anchor DX-I FAST ETA 1 | M6 | M8 | M10 | M12 |
|---------------------------------|----|----|-----|-----|
| Static or quasi-static action | | ✓ | | |
| Seismic action | | | | |
| Fire exposure | | ✓ | | |
| Cracked and non-cracked | | ✓ | | |

¹⁾ only for standard anchorage depth

²⁾ only cold formed anchors acc. to Annex A3

Base materials:

- Reinforced or unreinforced normal weight concrete according to EN 206-1: 2000
- Strength classes C20/25 to C50/60 according to EN 206-1: 2000

Use conditions (Environmental conditions):

- Structures subject to dry internal conditions (zinc plated steel, stainless steel or high corrosion resistant steel).
- Structures subject to external atmospheric exposure (including industrial and marine environment) and to permanently damp internal condition, if no particular aggressive conditions exist (stainless steel or high corrosion resistant steel).
- Structures subject to external atmospheric exposure and to permanently damp internal condition, if other particular aggressive conditions (high corrosion resistant steel)

Note: Particular aggressive conditions are e.g. permanent, alternating immersion in seawater or the splash zone of seawater, chloride atmosphere of indoor pools or atmosphere with extreme chemical pollution (e.g. in desulphurization plants or road tunnels where de-icing materials are used.)

Design:

- Anchorages are designed under the responsibility of an engineer experienced in anchorages and concrete work.
- Verifiable calculation notes and drawings are prepared taking account of the loads to be anchored. The position of the anchor is indicated on the design drawings (e.g. position of the anchor relative to reinforcement or to supports, etc.).
- Anchorages under static or quasi-static actions are designed in accordance with:
 - ETAG 001, Annex C, design method A, Edition August 2010 or
 - CEN/TS 1992-4: 2009, design method A
- Anchorages under seismic actions (cracked concrete) are designed in accordance with:
 - EOTA Technical Report TR 045, Edition February 2013
 - Anchorages shall be positioned outside of critical regions (e.g. plastic hinges) of the concrete structure
 - Fastenings in stand-off installation or with a grout layer are not allowed
- Anchorages under fire exposure are designed in accordance with:
 - EOTA Technical Report TR 020, Edition May 2004
 - CEN/TS 1992-4: 2009, Annex D
 (It must be ensured that local spalling of the concrete cover does not occur)

Ter Laare Wedge Anchor DX FAST ETA 1 and DX-I FAST ETA 1

Intended use
Specifications

Annex B1

Table B1: Installation parameters DX FAST ETA 1

| Anchor size | | | M8 | M10 | M12 | M16 | M20 | M24 | M27 | |
|---|--------------------|------------|------|-------|------|------|-------|-------|-------|-----|
| Nominal drill hole diameter | d_0 | [mm] | 8 | 10 | 12 | 16 | 20 | 24 | 28 | |
| Cutting diameter of drill bit | $d_{cut} \leq$ | [mm] | 8,45 | 10,45 | 12,5 | 16,5 | 20,55 | 24,55 | 28,55 | |
| Installation torque | Steel, zinc plated | T_{inst} | 20 | 25 | 45 | 90 | 160 | 200 | 300 | |
| | A4, HCR | T_{inst} | 20 | 35 | 50 | 110 | 200 | 290 | | |
| Diameter of clearance hole in the fixture | $d_f \leq$ | [mm] | 9 | 12 | 14 | 18 | 22 | 26 | 30 | |
| Standard anchorage depth | | | | | | | | | | |
| Depth of drill hole | Steel, zinc plated | $h_1 \geq$ | [mm] | 60 | 75 | 90 | 110 | 125 | 145 | 160 |
| | A4, HCR | $h_1 \geq$ | [mm] | 60 | 75 | 90 | 110 | 125 | 155 | |
| Effective anchorage depth | Steel, zinc plated | h_{ef} | [mm] | 46 | 60 | 70 | 85 | 100 | 115 | 125 |
| | A4, HCR | h_{ef} | [mm] | 46 | 60 | 70 | 85 | 100 | 125 | |
| Reduced anchorage depth | | | | | | | | | | |
| Depth of drill hole | $h_{1,red} \geq$ | [mm] | 49 | 55 | 70 | 90 | | | | |
| Reduced effective anchorage depth | $h_{ef,red}$ | [mm] | 35 | 40 | 50 | 65 | | | | |

Table B2: Min. spacings and edge distances, reduced anchorage depth, DX FAST ETA 1

| Anchor size | | | M8 | M10 | M12 | M16 |
|--------------------------------------|--------------|------|-----|-----|-----|-----|
| Minimum thickness of concrete member | $h_{min,3}$ | [mm] | 80 | 80 | 100 | 140 |
| Cracked concrete | | | | | | |
| Minimum spacing | s_{min} | [mm] | 50 | 50 | 50 | 65 |
| | for $c \geq$ | [mm] | 60 | 100 | 160 | 170 |
| Minimum edge distance | c_{min} | [mm] | 40 | 65 | 65 | 100 |
| | for $s \geq$ | [mm] | 185 | 180 | 250 | 250 |
| Non-cracked concrete | | | | | | |
| Minimum spacing | s_{min} | [mm] | 50 | 50 | 50 | 65 |
| | for $c \geq$ | [mm] | 60 | 100 | 160 | 170 |
| Minimum edge distance | c_{min} | [mm] | 40 | 65 | 100 | 170 |
| | for $s \geq$ | [mm] | 185 | 180 | 185 | 65 |

Ter Laare Wedge Anchor DX FAST ETA 1

Intended use
Installation parameters,
Minimum spacings and edge distances for reduced anchorage depth

Annex B2

Table B3: Min. spacings and edge distances, standard anchorage depth, DX FAST ETA 1

| Anchor size | | | M8 | M10 | M12 | M16 | M20 | M24 | M27 |
|--|--------------|------|--------------------------------|-----|-----|-----|-----|-----|-----|
| Standard thickness of concrete member | | | | | | | | | |
| Steel zinc plated | | | | | | | | | |
| Standard thickness of member | $h_{min,1}$ | [mm] | 100 | 120 | 140 | 170 | 200 | 230 | 250 |
| Cracked concrete | | | | | | | | | |
| Minimum spacing | s_{min} | [mm] | 40 | 45 | 60 | 60 | 95 | 100 | 125 |
| | for $c \geq$ | [mm] | 70 | 70 | 100 | 100 | 150 | 180 | 300 |
| Minimum edge distance | c_{min} | [mm] | 40 | 45 | 60 | 60 | 95 | 100 | 180 |
| | for $s \geq$ | [mm] | 80 | 90 | 140 | 180 | 200 | 220 | 540 |
| Non-cracked concrete | | | | | | | | | |
| Minimum spacing | s_{min} | [mm] | 40 | 45 | 60 | 65 | 90 | 100 | 125 |
| | for $c \geq$ | [mm] | 80 | 70 | 120 | 120 | 180 | 180 | 300 |
| Minimum edge distance | c_{min} | [mm] | 50 | 50 | 75 | 80 | 130 | 100 | 180 |
| | for $s \geq$ | [mm] | 100 | 100 | 150 | 150 | 240 | 220 | 540 |
| Stainless steel A4, HCR | | | | | | | | | |
| Standard thickness of member | $h_{min,1}$ | [mm] | 100 | 120 | 140 | 160 | 200 | 250 | |
| Cracked concrete | | | | | | | | | |
| Minimum spacing | s_{min} | [mm] | 40 | 50 | 60 | 60 | 95 | 125 | |
| | for $c \geq$ | [mm] | 70 | 75 | 100 | 100 | 150 | 125 | |
| Minimum edge distance | c_{min} | [mm] | 40 | 55 | 60 | 60 | 95 | 125 | |
| | for $s \geq$ | [mm] | 80 | 90 | 140 | 180 | 200 | 125 | |
| Non-cracked concrete | | | | | | | | | |
| Minimum spacing | s_{min} | [mm] | 40 | 50 | 60 | 65 | 90 | 125 | |
| | for $c \geq$ | [mm] | 80 | 75 | 120 | 120 | 180 | 125 | |
| Minimum edge distance | c_{min} | [mm] | 50 | 60 | 75 | 80 | 130 | 125 | |
| | for $s \geq$ | [mm] | 100 | 120 | 150 | 150 | 240 | 125 | |
| Minimum thickness of concrete member | | | | | | | | | |
| Steel zinc plated and stainless steel A4, HCR | | | | | | | | | |
| Minimum thickness of member | $h_{min,2}$ | [mm] | 80 | 100 | 120 | 140 | | | |
| Cracked concrete | | | | | | | | | |
| Minimum spacing | s_{min} | [mm] | 40 | 45 | 60 | 70 | | | |
| | for $c \geq$ | [mm] | 70 | 90 | 100 | 160 | | | |
| Minimum edge distance | c_{min} | [mm] | 40 | 50 | 60 | 80 | | | |
| | for $s \geq$ | [mm] | 80 | 115 | 140 | 180 | | | |
| Non-cracked concrete | | | | | | | | | |
| Minimum spacing | s_{min} | [mm] | 40 | 60 | 60 | 80 | | | |
| | for $c \geq$ | [mm] | 80 | 140 | 120 | 180 | | | |
| Minimum edge distance | c_{min} | [mm] | 50 | 90 | 75 | 90 | | | |
| | for $s \geq$ | [mm] | 100 | 140 | 150 | 200 | | | |
| Fire exposure from one side | | | | | | | | | |
| Minimum spacing | $s_{min,fi}$ | [mm] | See normal ambient temperature | | | | | | |
| Minimum edge distance | $c_{min,fi}$ | [mm] | See normal ambient temperature | | | | | | |
| Fire exposure from more than one side | | | | | | | | | |
| Minimum spacing | $s_{min,fi}$ | [mm] | See normal ambient temperature | | | | | | |
| Minimum edge distance | $c_{min,fi}$ | [mm] | ≥ 300 mm | | | | | | |

Intermediate values by linear interpolation.

Ter Laare Wedge Anchor DX FAST ETA 1

Intended use
Minimum spacings and edge distances for standard anchorage depth

Annex B3

Installation instructions DX FAST ETA 1

The fitness for use of the anchor can only be assumed if the anchor is installed as follows:

- Anchor installation carried out by appropriately qualified personnel and under the supervision of the person responsible for technical matters of the site,
- Use of the anchor only as supplied by the manufacturer without exchanging the components of the anchor.
- Checks before placing the anchor to ensure that the strength class of the concrete in which the anchor is to be placed is in the range given and is not lower than that of the concrete to which the characteristic loads apply
- Check of concrete being well compacted, e.g. without significant voids,
- Edge distances and spacing not less than the specified values without minus tolerances.

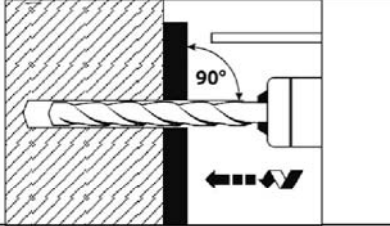
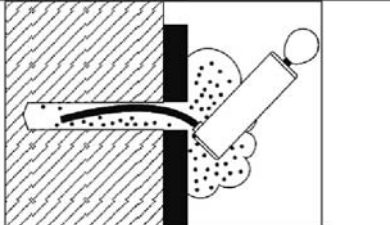
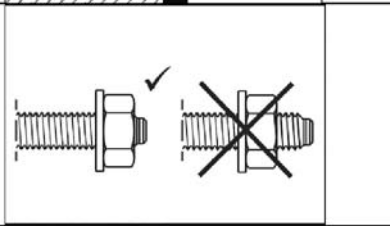
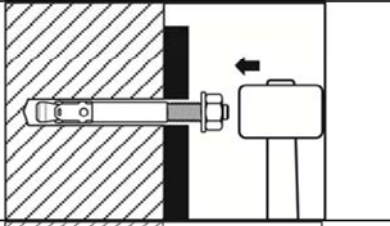
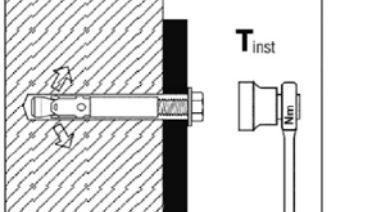
| | | |
|---|---|--|
| 1 |  | <p>Drill hole perpendicular to concrete surface, positioning without damaging the reinforcement.</p> <p>In case of aborted hole: new drilling at a minimum distance away of twice the depth of the aborted hole or smaller distance if the aborted drill hole is filled with high strength mortar and if under shear or oblique tension load it is not in the direction of load application.</p> |
| 2 |  | <p>Blow out dust. Alternatively vacuum clean down to the bottom of the hole.</p> |
| 3 |  | <p>Check position of nut.</p> |
| 4 |  | <p>Drive in anchor, such that h_{ef} or $h_{ef,red}$ depth is met. This compliance is ensured, if the thickness of fixture is not greater than the maximum thickness of fixture marked on the anchor in accordance with Annex A3.</p> |
| 5 |  | <p>Max. tightening torque T_{inst} shall be applied by using calibrated torque wrench.</p> |

Ter Laare Wedge Anchor DX FAST ETA 1

Intended Use
Installation instructions

Annex B4

Table B4: Installation parameters DX-I FAST ETA 1

| Anchor size | | | M6 | M8 | M10 | M12 |
|---|--------------------|------|------|-------|------|------|
| Effective anchorage depth | h_{ef} | [mm] | 45 | 58 | 65 | 80 |
| Drill hole diameter | d_0 | [mm] | 8 | 10 | 12 | 16 |
| Cutting diameter of drill bit | $d_{cut} \leq$ | [mm] | 8,45 | 10,45 | 12,5 | 16,5 |
| Depth of drill hole | $h_1 \geq$ | [mm] | 60 | 75 | 90 | 105 |
| Screwing depth of threaded rod | $L_{sd}^{2)} \geq$ | [mm] | 9 | 12 | 15 | 18 |
| Installation moment, zinc plated steel | S | [Nm] | 10 | 30 | 30 | 55 |
| | SK | [Nm] | 10 | 25 | 40 | 50 |
| | B | [Nm] | 8 | 25 | 30 | 45 |
| Installation moment, stainless steel A4, HCR | S | [Nm] | 15 | 40 | 50 | 100 |
| | SK | [Nm] | 12 | 25 | 45 | 60 |
| | B | [Nm] | 8 | 25 | 40 | 80 |
| Installation type V (Pre-setting installation) | | | | | | |
| Diameter of clearance hole in the fixture | $d_f \leq$ | [mm] | 7 | 9 | 12 | 14 |
| Minimum thickness of fixture | S | [mm] | 1 | 1 | 1 | 1 |
| | SK | [mm] | 5 | 7 | 8 | 9 |
| | B | [mm] | 1 | 1 | 1 | 1 |
| Installation type D (Through-setting installation) | | | | | | |
| Diameter of clearance hole in the fixture | $d_f \leq$ | [mm] | 9 | 12 | 14 | 18 |
| Minimum thickness of fixture ¹⁾ | S | [mm] | 5 | 7 | 8 | 9 |
| | SK | [mm] | 9 | 12 | 14 | 16 |
| | B | [mm] | 5 | 7 | 8 | 9 |

¹⁾ The minimum thickness of fixture can be reduced to the value of installation type V, if the shear load at steel failure is designed with lever arm.

²⁾ see Annex A2

Table B5: Minimum spacings and edge distances DX-I FAST ETA 1

| Anchor size | | | M6 | M8 | M10 | M12 |
|--|--------------|------|------------------------|-----|-----|-----|
| Minimum thickness of concrete member | h_{min} | [mm] | 100 | 120 | 130 | 160 |
| Cracked concrete | | | | | | |
| Minimum spacing | s_{min} | [mm] | 50 | 60 | 70 | 80 |
| | for $c \geq$ | [mm] | 60 | 80 | 100 | 120 |
| Minimum edge distance | c_{min} | [mm] | 50 | 60 | 70 | 80 |
| | for $s \geq$ | [mm] | 75 | 100 | 100 | 120 |
| Non-cracked concrete | | | | | | |
| Minimum spacing | s_{min} | [mm] | 50 | 60 | 65 | 80 |
| | for $c \geq$ | [mm] | 80 | 100 | 120 | 160 |
| Minimum edge distance | c_{min} | [mm] | 50 | 60 | 70 | 100 |
| | for $s \geq$ | [mm] | 115 | 155 | 170 | 210 |
| Fire exposure from one side | | | | | | |
| Minimum spacing | $s_{min,fi}$ | [mm] | See normal temperature | | | |
| Minimum edge distance | $c_{min,fi}$ | [mm] | See normal temperature | | | |
| Fire exposure from more than one side | | | | | | |
| Minimum spacing | $s_{min,fi}$ | [mm] | See normal temperature | | | |
| Minimum edge distance | $c_{min,fi}$ | [mm] | ≥ 300 mm | | | |

Ter Laare Wedge Anchor DX-I FAST ETA 1

Intended use
Installation parameters, minimum spacings and edge distances

Annex B5

Installation instructions **DX-I V FAST ETA 1**

The fitness for use of the anchor can only be assumed if the anchor is installed as follows:

- Anchor installation carried out by appropriately qualified personnel and under the supervision of the person responsible for technical matters of the site,
- Use of the anchor only as supplied by the manufacturer without exchanging the components of an anchor.
- Checks before placing the anchor to ensure that the strength class of the concrete in which the anchor is to be placed is in the range given and is not lower than that of the concrete to which the characteristic loads apply
- Check of concrete being well compacted, e.g. without significant voids,
- Edge distances and spacing not less than the specified values without minus tolerances.

Pre-setting installation

| | | |
|----------|--|--|
| 1 | | Drill hole perpendicular to concrete surface, positioning without damaging the reinforcement. In case of aborted hole: new drilling at a minimum distance away twice the depth of the aborted hole or smaller distance if the aborted drill hole is filled with high strength mortar and if under shear or oblique tension load it is not in the direction of load application. |
| 2 | | Blow out dust. Alternatively vacuum clean down to the bottom of the hole. |
| 3 | | Setting tool for pre-setting installation insert in anchor. |
| 4 | | Drive in anchor with setting tool. |
| 5 | | Drive in screw. |
| 6 | | Max. tightening torque T_{inst} may be applied by using calibrated torque wrench. |

Ter Laare Wedge Anchor DX-I FAST ETA 1

Intended Use
Installation instructions for pre-setting installation

Annex B6

Installation instructions **DX-I D FAST ETA 1**

Through-setting installation





| | | |
|---|--|--|
| 1 | | <p>Drill hole perpendicular to concrete surface, positioning without damaging the reinforcement.</p> <p>In case of aborted hole: new drilling at a minimum distance away of twice the depth of the aborted hole or smaller distance if the aborted drill hole is filled with high strength mortar and if under shear or oblique tension load it is not in the direction of load application.</p> |
| 2 | | <p>Blow out dust. Alternatively vacuum clean down to the bottom of the hole.</p> |
| 3 | | <p>Setting tool for through-setting installation insert in anchor.</p>  |
| 4 | | <p>Drive in anchor with setting tool.</p> |
| 5 | | <p>Drive in screw.</p> |
| 6 | | <p>Max. tightening torque T_{inst} may be applied by using calibrated torque wrench.</p> |

Ter Laare Wedge Anchor DX-I FAST ETA 1

Intended Use
Installation instructions for through-setting installation

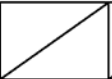
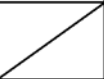
Annex B7

Table C1: Characteristic values for **tension loads**, DX FAST ETA 1 zinc plated, **cracked concrete**, static and quasi-static action, design method A according to ETAG 001, Annex C or CEN/TS 1992-4

| Anchor size | | | M8 | M10 | M12 | M16 | M20 | M24 | M27 |
|---|----------------------------|------|---|-----|-----|-----|---|---|---|
| Installation safety factor | $\gamma_2 = \gamma_{inst}$ | [-] | 1,0 | | | | | | |
| Steel failure | | | | | | | | | |
| Characteristic tension resistance | $N_{Rk,s}$ | [kN] | 16 | 27 | 40 | 60 | 86 | 126 | 196 |
| Partial safety factor | γ_{Ms} | [-] | 1,53 | | 1,5 | | 1,6 | 1,5 | |
| Pull-out | | | | | | | | | |
| Standard anchorage depth | | | | | | | | | |
| Characteristic resistance in concrete C20/25 | $N_{Rk,p}$ | [kN] | 5 | 9 | 16 | 25 | 1) | 1) | 1) |
| Reduced anchorage depth | | | | | | | | | |
| Characteristic resistance in concrete C20/25 | $N_{Rk,p,red}$ | [kN] | 5 | 7,5 | 1) | 1) |  |  |  |
| Increasing factor for $N_{Rk,p}$ and $N_{Rk,p,red}$ | ψ_c | [-] | $\left(\frac{f_{ck,cube}}{25}\right)^{0,5}$ | | | | | | |
| Concrete cone failure | | | | | | | | | |
| Effective anchorage depth | h_{ef} | [mm] | 46 | 60 | 70 | 85 | 100 | 115 | 125 |
| Reduced anchorage depth | $h_{ef,red}$ | [mm] | 35 ²⁾ | 40 | 50 | 65 |  |  |  |
| Factor according to CEN/TS 1992-4 | k_{cr} | [-] | 7,2 | | | | | | |

¹⁾ Pull-out is not decisive.

²⁾ Use restricted to anchoring of structural components statically indeterminate.

Ter Laare Wedge Anchor DX FAST ETA 1

Performance

Characteristic values for **tension loads**, DX FAST ETA 1 zinc plated **cracked concrete**, static and quasi-static action, design method A according to ETAG 001, Annex C or CEN/TS 1992-4

Annex C1

Table C2: Characteristic values for **tension loads, DX FAST ETA 1 A4 / HCR, cracked concrete**, static and quasi-static action, design method A according to ETAG 001, Annex C or CEN/TS 1992-4

| Anchor size | | | M8 | M10 | M12 | M16 | M20 | M24 |
|---|----------------------------|------|---|-----|-----|-----|------|-----|
| Installation safety factor | $\gamma_2 = \gamma_{inst}$ | [-] | 1,0 | | | | | |
| Steel failure | | | | | | | | |
| Characteristic tension resistance | $N_{Rk,s}$ | [kN] | 16 | 27 | 40 | 64 | 108 | 110 |
| Partial safety factor | γ_{Ms} | [-] | 1,5 | | | | 1,68 | 1,5 |
| Pull-out | | | | | | | | |
| Standard anchorage depth | | | | | | | | |
| Characteristic resistance in concrete C20/25 | $N_{Rk,p}$ | [kN] | 5 | 9 | 16 | 25 | 1) | 40 |
| Reduced anchorage depth | | | | | | | | |
| Characteristic resistance in concrete C20/25 | $N_{Rk,p,red}$ | [kN] | 5 | 7,5 | 1) | 1) | | |
| Increasing factor for $N_{Rk,p}$ and $N_{Rk,p,red}$ | ψ_c | [-] | $\left(\frac{f_{ck,cube}}{25}\right)^{0,5}$ | | | | | |
| Concrete cone failure | | | | | | | | |
| Effective anchorage depth | h_{ef} | [mm] | 46 | 60 | 70 | 85 | 100 | 125 |
| Reduced anchorage depth | $h_{ef,red}$ | [mm] | 35 ²⁾ | 40 | 50 | 65 | | |
| Factor according to CEN/TS 1992-4 | k_{cr} | [-] | 7,2 | | | | | |

¹⁾ Pull-out is not decisive.

²⁾ Use restricted to anchoring of structural components statically indeterminate.

Ter Laare Wedge Anchor DX FAST ETA 1

Performance

Characteristic values for **tension loads, DX FAST ETA 1 A4 / HCR, cracked concrete**, static and quasi-static action, design method A according to ETAG 001, Annex C or CEN/TS 1992-4

Annex C2

Table C3: Characteristic values for **tension loads**, DX FAST ETA 1 zinc plated, **non-cracked concrete**, static and quasi-static action, design method A according to ETAG 001, Annex C or CEN/TS 1992-4

| Anchor size | | M8 | M10 | M12 | M16 | M20 | M24 | M27 |
|---|----------------------------------|---|-----|-----|-----|--------------|------------|------------|
| Installation safety factor | $\gamma_2 = \gamma_{inst}$ [-] | 1,0 | | | | | | |
| Steel failure | | | | | | | | |
| Characteristic tension resistance | $N_{Rk,s}$ [kN] | 16 | 27 | 40 | 60 | 86 | 126 | 196 |
| Partial safety factor | γ_{Ms} [-] | 1,53 | | 1,5 | | 1,6 | 1,5 | |
| Pull-out | | | | | | | | |
| Standard anchorage depth | | | | | | | | |
| Characteristic resistance in non-cracked concrete C20/25 | $N_{Rk,p}$ [kN] | 12 | 16 | 25 | 35 | 1) | 1) | 1) |
| Reduced anchorage depth | | | | | | | | |
| Characteristic resistance in non-cracked concrete C20/25 | $N_{Rk,p,red}$ [kN] | 7,5 | 9 | 1) | 1) | / | / | / |
| Splitting For the proof against splitting failure $N_{Rk,c}^0$ has to be replaced by $N_{Rk,sp}^0$ with consideration of the member thickness | | | | | | | | |
| Standard anchorage depth | | | | | | | | |
| Splitting for standard thickness of concrete member (The higher resistance of case 1 and case 2 may be applied; the values $s_{cr,sp}$ and $c_{cr,sp}$ may be linearly interpolated for the member thickness $h_{min} < h < h_{std}$ (Case 2); $\psi_{h,sp} = 1,0$) | | | | | | | | |
| Standard thickness of concrete | $h_{min,1} \geq$ [mm] | 100 | 120 | 140 | 170 | 200 | 230 | 250 |
| Case 1 | | | | | | | | |
| Characteristic resistance in non-cracked concrete C20/25 | $N_{Rk,sp}^0$ [kN] | 9 | 12 | 20 | 30 | 40 | 1) | 50 |
| Spacing (edge distance) | $s_{cr,sp} (= 2 c_{cr,sp})$ [mm] | 3 h_{ef} | | | | | | |
| Case 2 | | | | | | | | |
| Characteristic resistance in non-cracked concrete C20/25 | $N_{Rk,sp}^0$ [kN] | 12 | 16 | 25 | 35 | 1) | 1) | 1) |
| Spacing (edge distance) | $s_{cr,sp} (= 2 c_{cr,sp})$ [mm] | 4 h_{ef} | | | | 4,4 h_{ef} | 3 h_{ef} | 5 h_{ef} |
| Splitting for minimum thickness of concrete member | | | | | | | | |
| Minimum thickness of concrete | $h_{min,2} \geq$ [mm] | 80 | 100 | 120 | 140 | / | / | / |
| Characteristic resistance in non-cracked concrete C20/25 | $N_{Rk,sp}^0$ [kN] | 12 | 16 | 25 | 35 | / | / | / |
| Spacing (edge distance) | $s_{cr,sp} (= 2 c_{cr,sp})$ [mm] | 5 h_{ef} | | | | / | / | / |
| Reduced anchorage depth | | | | | | | | |
| Minimum thickness of concrete | $h_{min,3} \geq$ [mm] | 80 | 80 | 100 | 140 | / | / | / |
| Characteristic resistance in non-cracked concrete C20/25 | $N_{Rk,sp}^0$ [kN] | 7,5 | 9 | 1) | 1) | / | / | / |
| Spacing (edge distance) | $s_{cr,sp} (= 2 c_{cr,sp})$ [mm] | 200 | 200 | 250 | 300 | / | / | / |
| Increasing factor for $N_{Rk,p(red)}$ and $N_{Rk,sp}^0$ | ψ_c [-] | $\left(\frac{f_{ck,cube}}{25}\right)^{0,5}$ | | | | | | |
| Concrete cone failure | | | | | | | | |
| Effective anchorage depth | h_{ef} [mm] | 46 | 60 | 70 | 85 | 100 | 115 | 125 |
| Reduced anchorage depth | $h_{ef,red}$ [mm] | 35 ²⁾ | 40 | 50 | 65 | / | / | / |
| Factor according to CEN/TS 1992-4 | k_{ucr} [-] | 10,1 | | | | | | |

1) Pull-out is not decisive.

2) Use restricted to anchoring of structural components statically indeterminate.

Ter Laare Wedge Anchor DX FAST ETA 1

Performance

Characteristic values for **tension loads**, DX FAST ETA 1 zinc plated, **non-cracked concrete**, static and quasi-static action, design method A according to ETAG 001, Annex C or CEN/TS 1992-4

Annex C3

Table C4: Characteristic values for **tension loads**, DX FAST ETA 1 A4 / HCR, **non-cracked concrete**, static and quasi-static action, design method A according to ETAG 001, Annex C or CEN/TS 1992-4

| Anchor size | | | M8 | M10 | M12 | M16 | M20 | M24 |
|---|-----------------------------|------|---|-----|-----|-----|------|-----|
| Installation safety factor | $\gamma_2 = \gamma_{inst}$ | [-] | 1,0 | | | | | |
| Steel failure | | | | | | | | |
| Characteristic tension resistance | $N_{Rk,s}$ | [kN] | 16 | 27 | 40 | 64 | 108 | 110 |
| Partial safety factor | γ_{Ms} | [-] | 1,5 | | | | 1,68 | 1,5 |
| Pull-out | | | | | | | | |
| Standard anchorage depth | | | | | | | | |
| Characteristic resistance in non-cracked concrete C20/25 | $N_{Rk,p}$ | [kN] | 12 | 16 | 25 | 35 | 1) | 1) |
| Reduced anchorage depth | | | | | | | | |
| Characteristic resistance in non-cracked concrete C20/25 | $N_{Rk,p,red}$ | [kN] | 7,5 | 9 | 1) | 1) | | |
| Splitting For the proof against splitting failure $N_{Rk,c}^0$ has to be replaced by $N_{Rk,sp}^0$ with consideration of the member thickness | | | | | | | | |
| Standard anchorage depth | | | | | | | | |
| Splitting for standard thickness of concrete member (The higher resistance of case 1 and case 2 may be applied; the values $s_{cr,sp}$ and $c_{cr,sp}$ may be linearly interpolated for the member thickness $h_{min} < h < h_{std}$ (Case 2); $\psi_{h,sp} = 1,0$) | | | | | | | | |
| Standard thickness of concrete | $h_{min,1} \geq$ | [mm] | 100 | 120 | 140 | 160 | 200 | 250 |
| Case 1 | | | | | | | | |
| Characteristic resistance in non-cracked concrete C20/25 | $N_{Rk,sp}^0$ | [kN] | 9 | 12 | 20 | 30 | 40 | |
| Spacing (edge distance) | $s_{cr,sp} (= 2 c_{cr,sp})$ | [mm] | 3 h_{ef} | | | | | |
| Case 2 | | | | | | | | |
| Characteristic resistance in non-cracked concrete C20/25 | $N_{Rk,sp}^0$ | [kN] | 12 | 16 | 25 | 35 | 1) | 1) |
| Spacing (edge distance) | $s_{cr,sp} (= 2 c_{cr,sp})$ | [mm] | 230 | 250 | 280 | 400 | 440 | 500 |
| Splitting for minimum thickness of concrete member | | | | | | | | |
| Minimum thickness of concrete | $h_{min,2} \geq$ | [mm] | 80 | 100 | 120 | 140 | | |
| Characteristic resistance in non-cracked concrete C20/25 | $N_{Rk,sp}^0$ | [kN] | 12 | 16 | 25 | 35 | | |
| Spacing (edge distance) | $s_{cr,sp} (= 2 c_{cr,sp})$ | [mm] | 5 h_{ef} | | | | | |
| Reduced anchorage depth | | | | | | | | |
| Minimum thickness of concrete | $h_{min,3} \geq$ | [mm] | 80 | 80 | 100 | 140 | | |
| Characteristic resistance in non-cracked concrete C20/25 | $N_{Rk,sp}^0$ | [kN] | 7,5 | 9 | 1) | 1) | | |
| Spacing (edge distance) | $s_{cr,sp} (= 2 c_{cr,sp})$ | [mm] | 200 | 200 | 250 | 300 | | |
| Increasing factor for $N_{Rk,p(red)}$ and $N_{Rk,sp}^0$ | ψ_c | [-] | $\left(\frac{f_{ck,cube}}{25}\right)^{0,5}$ | | | | | |
| Concrete cone failure | | | | | | | | |
| Effective anchorage depth | h_{ef} | [mm] | 46 | 60 | 70 | 85 | 100 | 125 |
| Reduced anchorage depth | $h_{ef,red}$ | [mm] | 35 ²⁾ | 40 | 50 | 65 | | |
| Factor according to CEN/TS 1992-4 | k_{ucr} | [-] | 10,1 | | | | | |

¹⁾ Pull-out is not decisive.

²⁾ Use restricted to anchoring of structural components statically indeterminate.

Ter Laare Wedge Anchor DX FAST ETA 1

Performance

Characteristic values for **tension loads**, DX FAST ETA 1 A4 / HCR, **non-cracked concrete**, static and quasi-static action, design method A according to ETAG 001, Annex C or CEN/TS 1992-4

Annex C4

English translation prepared by DIBt

Table C5: Characteristic values for **shear loads**, DX FAST ETA 1, **cracked** and **non-cracked concrete**, static or quasi static action, design method A according to ETAG 001, Annex C or CEN/TS 1992-4

| Anchor size | | M8 | M10 | M12 | M16 | M20 | M24 | M27 | |
|---|--------------------------------|------------------|------|-----|------|-----|-------|--------|------|
| Installation safety factor | $\gamma_2 = \gamma_{inst}$ [-] | 1,0 | | | | | | | |
| Steel failure without lever arm, Steel zinc plated | | | | | | | | | |
| Characteristic shear resistance | $V_{Rk,s}$ [kN] | 12,2 | 20,1 | 30 | 55 | 69 | 114 | 169,4 | |
| Factor for ductility | k_2 [-] | 1,0 | | | | | | | |
| Partial safety factor | γ_{Ms} [-] | 1,25 | | | 1,33 | | | 1,25 | 1,25 |
| Steel failure without lever arm, Stainless steel A4, HCR | | | | | | | | | |
| Characteristic shear resistance | $V_{Rk,s}$ [kN] | 13 | 20 | 30 | 55 | 86 | 123,6 | / | |
| Factor for ductility | k_2 [-] | 1,0 | | | | | | | |
| Partial safety factor | γ_{Ms} [-] | 1,25 | | | 1,4 | | 1,25 | | |
| Steel failure with lever arm, Steel zinc plated | | | | | | | | | |
| Characteristic bending resistance | $M^0_{Rk,s}$ [Nm] | 23 | 47 | 82 | 216 | 363 | 898 | 1331,5 | |
| Partial safety factor | γ_{Ms} [-] | 1,25 | | | 1,33 | | 1,25 | 1,25 | |
| Steel failure with lever arm, Stainless steel A4, HCR | | | | | | | | | |
| Characteristic bending resistance | $M^0_{Rk,s}$ [Nm] | 26 | 52 | 92 | 200 | 454 | 785,4 | / | |
| Partial safety factor | γ_{Ms} [-] | 1,25 | | | 1,4 | | 1,25 | | |
| Concrete pry-out failure | | | | | | | | | |
| Factor k acc. ETAG 001, Annex C or k_3 acc. CEN/TS 1992-4 | $k_{(3)}$ [-] | 2,4 | | | 2,8 | | | | |
| Concrete edge failure | | | | | | | | | |
| Effective length of anchor in shear loading with h_{ef} | Steel zinc plated | l_f [mm] | 46 | 60 | 70 | 85 | 100 | 115 | 125 |
| | Stainless steel A4, HCR | l_f [mm] | 46 | 60 | 70 | 85 | 100 | 125 | / |
| Effective length of anchor in shear loading with $h_{ef,red}$ | Steel zinc plated | $l_{f,red}$ [mm] | 35 | 40 | 50 | 65 | / | / | |
| | Stainless steel A4, HCR | $l_{f,red}$ [mm] | 35 | 40 | 50 | 65 | | | |
| Outside diameter of anchor | d_{nom} [mm] | 8 | 10 | 12 | 16 | 20 | 24 | 27 | |

Ter Laare Wedge Anchor DX FAST ETA 1

Performance

Characteristic values for **shear loads**, DX FAST ETA 1, **cracked** and **non-cracked concrete**, static or quasi static action, design method A according to ETAG 001, Annex C or CEN/TS 1992-4

Annex C5

Table C6: Characteristic resistance for **seismic loading**, DX FAST ETA 1, **standard anchorage depth**, performance category **C1** and **C2**, design according to TR045

| Tension loads | | | | | | |
|---|-------------------------|--|------|------|------|------|
| Anchor size | | | M10 | M12 | M16 | M20 |
| Installation safety factor $\gamma_2 = \gamma_{inst}$ [-] | | | 1,0 | | | |
| Steel failure, steel zinc plated | | | | | | |
| Characteristic resistance C1 | $N_{Rk,s,seis,C1}$ [kN] | | 27 | 40 | 60 | 86 |
| Characteristic resistance C2 | $N_{Rk,s,seis,C2}$ [kN] | | 27 | 40 | 60 | 86 |
| Partial safety factor $\gamma_{Ms,seis}$ [-] | | | 1,53 | 1,5 | | 1,6 |
| Steel failure, stainless steel A4, HCR | | | | | | |
| Characteristic resistance C1 | $N_{Rk,s,seis,C1}$ [kN] | | 27 | 40 | 64 | 108 |
| Characteristic resistance C2 | $N_{Rk,s,seis,C2}$ [kN] | | 27 | 40 | 64 | 108 |
| Partial safety factor $\gamma_{Ms,seis}$ [-] | | | 1,5 | | 1,68 | |
| Pull-out | | | | | | |
| Characteristic resistance C1 | $N_{Rk,p,seis,C1}$ [kN] | | 9 | 16 | 25 | 36 |
| Characteristic resistance C2 | $N_{Rk,p,seis,C2}$ [kN] | | 3,6 | 10,2 | 13,8 | 22,4 |
| Shear loads | | | | | | |
| Steel failure without lever arm, Steel zinc plated | | | | | | |
| Characteristic resistance C1 | $V_{Rk,s,seis,C1}$ [kN] | | 20 | 27 | 44 | 69 |
| Characteristic resistance C2 | $V_{Rk,s,seis,C2}$ [kN] | | 14 | 16,2 | 35,7 | 55,2 |
| Partial safety factor $\gamma_{Ms,seis}$ [-] | | | 1,25 | | 1,33 | |
| Steel failure without lever arm, Stainless steel A4, HCR | | | | | | |
| Characteristic resistance C1 | $V_{Rk,s,seis,C1}$ [kN] | | 20 | 27 | 44 | 69 |
| Characteristic resistance C2 | $V_{Rk,s,seis,C2}$ [kN] | | 14 | 16,2 | 35,7 | 55,2 |
| Partial safety factor $\gamma_{Ms,seis}$ [-] | | | 1,25 | | 1,4 | |

Ter Laare Wedge Anchor DX FAST ETA 1

Performance
Characteristic resistance for **seismic loading**, DX FAST ETA 1, **standard anchorage depth**, performance category **C1** and **C2**, design according to TR045

Annex C6

Table C7: Characteristic values for tension and shear load under fire exposure, DX FAST ETA 1, standard anchorage depth, cracked and non-cracked concrete C20/25 to C50/60, design acc. to TR 020 or CEN/TS 1992-4, Annex D

| Anchor size | | M8 | M10 | M12 | M16 | M20 | M24 | M27 | | |
|--|------|-----------------|------|-----|-----|------|------|------|-------|------|
| Tension load | | | | | | | | | | |
| Steel failure | | | | | | | | | | |
| Steel zinc plated | | | | | | | | | | |
| Characteristic resistance | R30 | $N_{Rk,s,fi}$ | [kN] | 1,4 | 2,2 | 3,2 | 6,0 | 9,4 | 13,6 | 17,6 |
| | R60 | | | 1,1 | 1,8 | 2,8 | 5,2 | 8,2 | 11,8 | 15,3 |
| | R90 | | | 0,8 | 1,4 | 2,4 | 4,4 | 6,9 | 10,0 | 13,0 |
| | R120 | | | 0,7 | 1,2 | 2,2 | 4,0 | 6,3 | 9,1 | 11,8 |
| Stainless steel A4, HCR | | | | | | | | | | |
| Characteristic resistance | R30 | $N_{Rk,s,fi}$ | [kN] | 3,8 | 6,9 | 11,5 | 21,5 | 33,5 | 48,2 | |
| | R60 | | | 2,9 | 5,2 | 8,6 | 16 | 25,0 | 35,9 | |
| | R90 | | | 2,0 | 3,5 | 5,6 | 10,5 | 16,4 | 23,6 | |
| | R120 | | | 1,6 | 2,7 | 4,2 | 7,8 | 12,1 | 17,4 | |
| Shear load | | | | | | | | | | |
| Steel failure without lever arm | | | | | | | | | | |
| Steel zinc plated | | | | | | | | | | |
| Characteristic resistance | R30 | $V_{Rk,s,fi}$ | [kN] | 1,6 | 2,6 | 3,8 | 7,0 | 11 | 16 | 20,6 |
| | R60 | | | 1,5 | 2,5 | 3,6 | 6,8 | 11 | 15 | 19,8 |
| | R90 | | | 1,2 | 2,1 | 3,5 | 6,5 | 10 | 15 | 19,0 |
| | R120 | | | 1,0 | 2,0 | 3,4 | 6,4 | 10 | 14 | 18,6 |
| Stainless steel A4, HCR | | | | | | | | | | |
| Characteristic resistance | R30 | $V_{Rk,s,fi}$ | [kN] | 3,8 | 6,9 | 11,5 | 21,5 | 33,5 | 48,2 | |
| | R60 | | | 2,9 | 5,2 | 8,6 | 16 | 25,0 | 35,9 | |
| | R90 | | | 2,0 | 3,5 | 5,6 | 10,5 | 16,4 | 23,6 | |
| | R120 | | | 1,6 | 2,7 | 4,2 | 7,8 | 12,1 | 17,4 | |
| Steel failure with lever arm | | | | | | | | | | |
| Steel zinc plated | | | | | | | | | | |
| Characteristic resistance | R30 | $M^0_{Rk,s,fi}$ | [Nm] | 1,7 | 3,3 | 5,9 | 15 | 29 | 50 | 75 |
| | R60 | | | 1,6 | 3,2 | 5,6 | 14 | 28 | 48 | 72 |
| | R90 | | | 1,2 | 2,7 | 5,4 | 14 | 27 | 47 | 69 |
| | R120 | | | 1,1 | 2,5 | 5,3 | 13 | 26 | 46 | 68 |
| Stainless steel A4, HCR | | | | | | | | | | |
| Characteristic resistance | R30 | $M^0_{Rk,s,fi}$ | [Nm] | 3,8 | 9,0 | 17,9 | 45,5 | 88,8 | 153,5 | |
| | R60 | | | 2,9 | 6,8 | 13,3 | 33,9 | 66,1 | 114,3 | |
| | R90 | | | 2,1 | 4,5 | 8,8 | 22,2 | 43,4 | 75,1 | |
| | R120 | | | 1,6 | 3,4 | 6,5 | 16,4 | 32,1 | 55,5 | |

The characteristic resistance for pull-out failure, concrete cone failure, concrete pry-out and concrete edge failure can be calculated according to TR020 / CEN/TS 1992-4. If pull-out is not decisive $N_{Rk,p}$ in Eq. 2.4 and Eq. 2.5, TR 020 must be replaced by $N^0_{Rk,c}$.

Ter Laare Wedge Anchor DX FAST ETA 1

Performance

Characteristic values for tension and shear load under fire exposure, DX FAST ETA 1, standard anchorage depth, cracked and non-cracked concrete C20/25 to C50/60, design acc. to TR 020 or CEN/TS 1992-4, Annex D

Annex C7

Table C8: Displacements under tension load, DX FAST ETA 1

| Anchor size | | | M8 | M10 | M12 | M16 | M20 | M24 | M27 |
|---|---------------------------|------|-----|------|------|------|------|------|-----|
| Standard anchorage depth | | | | | | | | | |
| Steel zinc plated | | | | | | | | | |
| Tension load in cracked concrete | N | [kN] | 2,4 | 4,3 | 7,6 | 11,9 | 17,1 | 21,1 | 24 |
| Displacement | δ_{N0} | [mm] | 0,6 | 1,0 | 0,4 | 1,0 | 0,9 | 0,7 | 0,9 |
| | $\delta_{N\infty}$ | [mm] | 1,4 | 1,2 | 1,4 | 1,3 | 1,0 | 1,2 | 1,4 |
| Tension load in non-cracked concrete | N | [kN] | 5,7 | 7,6 | 11,9 | 16,7 | 23,8 | 29,6 | 34 |
| Displacement | δ_{N0} | [mm] | 0,4 | 0,5 | 0,7 | 0,3 | 0,4 | 0,5 | 0,3 |
| | $\delta_{N\infty}$ | [mm] | 0,8 | | 1,4 | 0,8 | | 1,4 | |
| Displacements under seismic tension loads C2 | | | | | | | | | |
| Displacements for DLS | $\delta_{N,seis,C2(DLS)}$ | [mm] | / | 4,1 | 4,9 | 3,6 | 5,1 | / | / |
| Displacements for ULS | $\delta_{N,seis,C2(ULS)}$ | [mm] | / | 13,8 | 15,7 | 9,5 | 15,2 | / | / |
| Stainless steel A4, HCR | | | | | | | | | |
| Tension load in cracked concrete | N | [kN] | 2,4 | 4,3 | 7,6 | 11,9 | 17,1 | 19,0 | / |
| Displacement | δ_{N0} | [mm] | 0,7 | 1,8 | 0,4 | 0,7 | 0,9 | 0,5 | / |
| | $\delta_{N\infty}$ | [mm] | 1,2 | 1,4 | 1,4 | 1,4 | 1,0 | 1,8 | / |
| Tension load in non-cracked concrete | N | [kN] | 5,8 | 7,6 | 11,9 | 16,7 | 23,8 | 33,5 | / |
| Displacement | δ_{N0} | [mm] | 0,6 | 0,5 | 0,7 | 0,2 | 0,4 | 0,5 | / |
| | $\delta_{N\infty}$ | [mm] | 1,2 | 1,0 | 1,4 | 0,4 | 0,8 | 1,1 | / |
| Displacements under seismic tension loads C2 | | | | | | | | | |
| Displacements for DLS | $\delta_{N,seis,C2(DLS)}$ | [mm] | / | 4,1 | 4,9 | 3,6 | 5,1 | / | / |
| Displacements for ULS | $\delta_{N,seis,C2(ULS)}$ | [mm] | / | 13,8 | 15,7 | 9,5 | 15,2 | / | / |
| Reduced anchorage depth | | | | | | | | | |
| Tension load in cracked concrete | N | [kN] | 2,4 | 3,6 | 6,1 | 9,0 | / | / | / |
| Displacement | δ_{N0} | [mm] | 0,8 | 0,7 | 0,5 | 1,0 | / | / | / |
| | $\delta_{N\infty}$ | [mm] | 1,2 | 1,0 | 0,8 | 1,1 | / | / | / |
| Tension load in non-cracked concrete | N | [kN] | 3,7 | 4,3 | 8,5 | 12,6 | / | / | / |
| Displacement | δ_{N0} | [mm] | 0,1 | 0,2 | 0,2 | 0,2 | / | / | / |
| | $\delta_{N\infty}$ | [mm] | 0,7 | 0,7 | 0,7 | 0,7 | / | / | / |

Ter Laare Wedge Anchor DX FAST ETA 1

Performance
Displacements under tension load

Annex C8

Table C9: Displacements under shear load, DX FAST ETA 1

| Anchor size | | | M8 | M10 | M12 | M16 | M20 | M24 | M27 |
|---|---------------------------|------|-----|------|------|------|------|------|------|
| Standard anchorage depth | | | | | | | | | |
| Steel zinc plated | | | | | | | | | |
| Shear load in cracked and non-cracked concrete | V | [kN] | 6,9 | 11,4 | 17,1 | 31,4 | 36,8 | 64,9 | 96,8 |
| Displacement | δ_{V0} | [mm] | 2,0 | 3,2 | 3,6 | 3,5 | 1,8 | 3,5 | 3,6 |
| | $\delta_{V\infty}$ | [mm] | 3,0 | 4,7 | 5,5 | 5,3 | 2,7 | 5,3 | 5,4 |
| Displacements under seismic shear loads C2 | | | | | | | | | |
| Displacements for DLS | $\delta_{V,seis,C2(DLS)}$ | [mm] | / | 2,7 | 3,5 | 4,3 | 4,7 | / | / |
| Displacements for ULS | $\delta_{V,seis,C2(ULS)}$ | [mm] | / | 5,3 | 9,5 | 9,6 | 10,1 | / | / |
| Stainless steel A4, HCR | | | | | | | | | |
| Shear load in cracked and non-cracked concrete | V | [kN] | 7,3 | 11,4 | 17,1 | 31,4 | 43,8 | 70,6 | / |
| Displacement | δ_{V0} | [mm] | 1,9 | 2,4 | 4,0 | 4,3 | 2,9 | 2,8 | / |
| | $\delta_{V\infty}$ | [mm] | 2,9 | 3,6 | 5,9 | 6,4 | 4,3 | 4,2 | / |
| Displacements under seismic shear loads C2 | | | | | | | | | |
| Displacements for DLS | $\delta_{V,seis,C2(DLS)}$ | [mm] | / | 2,7 | 3,5 | 4,3 | 4,7 | / | / |
| Displacements for ULS | $\delta_{V,seis,C2(ULS)}$ | [mm] | / | 5,3 | 9,5 | 9,6 | 10,1 | / | / |
| Reduced anchorage depth | | | | | | | | | |
| Steel zinc plated | | | | | | | | | |
| Shear load in cracked and non-cracked concrete | V | [kN] | 6,9 | 11,4 | 17,1 | 31,4 | / | / | / |
| Displacement | δ_{V0} | [mm] | 2,0 | 3,2 | 3,6 | 3,5 | / | / | / |
| | $\delta_{V\infty}$ | [mm] | 3,0 | 4,7 | 5,5 | 5,3 | / | / | / |
| Stainless steel A4, HCR | | | | | | | | | |
| Shear load in cracked and non-cracked concrete | V | [kN] | 7,3 | 11,4 | 17,1 | 31,4 | / | / | / |
| Displacement | δ_{V0} | [mm] | 1,9 | 2,4 | 4,0 | 4,3 | / | / | / |
| | $\delta_{V\infty}$ | [mm] | 2,9 | 3,6 | 5,9 | 6,4 | / | / | / |

Ter Laare Wedge Anchor DX FAST ETA 1

Performance
Displacements under shear load

Annex C9

Table C10: Characteristic values for **tension loads, DX-I FAST ETA 1, cracked concrete**, static and quasi-static action, design method A according to ETAG 001, Annex C or CEN/TS 1992-4

| Anchor size | | | M6 | M8 | M10 | M12 |
|--|----------------------------|------|---|------|------|------|
| Installation safety factor | $\gamma_2 = \gamma_{inst}$ | [-] | 1,2 | | | |
| Steel failure | | | | | | |
| Characteristic tension resistance, steel zinc plated | $N_{Rk,s}$ | [kN] | 16,1 | 22,6 | 26,0 | 56,6 |
| Partial safety factor | γ_{Ms} | [-] | 1,5 | | | |
| Characteristic tension resistance, stainless steel A4, HCR | $N_{Rk,s}$ | [kN] | 14,1 | 25,6 | 35,8 | 59,0 |
| Partial safety factor | γ_{Ms} | [-] | 1,87 | | | |
| Pull-out failure | | | | | | |
| Characteristic resistance in cracked concrete C20/25 | $N_{Rk,p}$ | [kN] | 5 | 9 | 12 | 20 |
| Increasing factor | ψ_c | [-] | $\left(\frac{f_{ck,cube}}{25}\right)^{0,5}$ | | | |
| Concrete cone failure | | | | | | |
| Effective anchorage depth | h_{ef} | [mm] | 45 | 58 | 65 | 80 |
| Factor according to CEN/TS 1992-4 | k_{cr} | [-] | 7,2 | | | |

Ter Laare Wedge Anchor DX-I FAST ETA 1

Performance

Characteristic values for **tension loads, DX-I FAST ETA 1, cracked concrete**, static and quasi-static action, design method A according to ETAG 001, Annex C or CEN/TS 1992-4

Annex C10

Table C11: Characteristic values for **tension loads, DX-I FAST ETA 1, non-cracked concrete**, static and quasi-static action, design method A according to ETAG 001, Annex C or CEN/TS 1992-4

| Anchor size | | | M6 | M8 | M10 | M12 |
|---|-----------------------------|------|---|------|------|------|
| Installation safety factor | $\gamma_2 = \gamma_{inst}$ | [-] | 1,2 | | | |
| Steel failure | | | | | | |
| Characteristic tension resistance, steel zinc plated | $N_{Rk,s}$ | [kN] | 16,1 | 22,6 | 26,0 | 56,6 |
| Partial safety factor | γ_{Ms} | [-] | 1,5 | | | |
| Characteristic tension resistance, stainless steel A4, HCR | $N_{Rk,s}$ | [kN] | 14,1 | 25,6 | 35,8 | 59,0 |
| Partial safety factor | γ_{Ms} | [-] | 1,87 | | | |
| Pull-out | | | | | | |
| Characteristic resistance in non-cracked concrete C20/25 | $N_{Rk,p}$ | [kN] | 12 | 16 | 20 | 30 |
| Splitting ($N_{Rk,c}^0$ has to be replaced by $N_{Rk,sp}^0$. The higher resistance of Case 1 and Case 2 may be applied.) | | | | | | |
| Minimum thickness of concrete member | h_{min} | [mm] | 100 | 120 | 130 | 160 |
| Case 1 | | | | | | |
| Characteristic resistance in non-cracked concrete C20/25 | $N_{Rk,sp}^0$ | [kN] | 9 | 12 | 16 | 25 |
| Spacing (edge distance) | $s_{cr,sp} (= 2 c_{cr,sp})$ | [mm] | 3 h_{ef} | | | |
| Case 2 | | | | | | |
| Characteristic resistance in non-cracked concrete C20/25 | $N_{Rk,sp}^0$ | [kN] | 12 | 16 | 20 | 30 |
| Spacing (edge distance) | $s_{cr,sp} (= 2 c_{cr,sp})$ | [mm] | 5 h_{ef} | | | |
| Increasing factor for $N_{Rk,p}$ and $N_{Rk,sp}^0$ | ψ_c | [-] | $\left(\frac{f_{ck,cube}}{25}\right)^{0,5}$ | | | |
| Concrete cone failure | | | | | | |
| Effective anchorage depth | h_{ef} | [mm] | 45 | 58 | 65 | 80 |
| Factor according to CEN/TS 1992-4 | k_{ucr} | [-] | 10,1 | | | |

Ter Laare Wedge Anchor DX-I FAST ETA 1

Performance

Characteristic values for **tension loads, DX-I FAST ETA 1, non-cracked concrete**, static and quasi-static action, design method A according to ETAG 001, Annex C or CEN/TS 1992-4

Annex C11

Table C12: Characteristic values for shear loads, **DX-I FAST ETA 1, cracked and non-cracked concrete, static and quasi-static action, design method A according to ETAG 001, Annex C or CEN/TS 1992-4**

| Anchor size | | | M6 | M8 | M10 | M12 |
|---|----------------------------|------|------|------|------|-------|
| Installation safety factor | $\gamma_2 = \gamma_{inst}$ | [-] | 1,0 | | | |
| DX-I FAST ETA 1, steel zinc plated | | | | | | |
| Steel failure without lever arm, Installation type V | | | | | | |
| Characteristic shear resistance | $V_{Rk,s}$ | [kN] | 5,8 | 6,9 | 10,4 | 25,8 |
| Steel failure without lever arm, Installation type D | | | | | | |
| Characteristic shear resistance | $V_{Rk,s}$ | [kN] | 5,1 | 7,6 | 10,8 | 24,3 |
| Steel failure with lever arm, Installation type V | | | | | | |
| Characteristic bending resistance | $M^0_{Rk,s}$ | [Nm] | 12,2 | 30,0 | 59,8 | 104,6 |
| Steel failure with lever arm, Installation type D | | | | | | |
| Characteristic bending resistance | $M^0_{Rk,s}$ | [Nm] | 36,0 | 53,2 | 76,0 | 207 |
| Partial safety factor for $V_{Rk,s}$ and $M^0_{Rk,s}$ | γ_{Ms} | [-] | 1,25 | | | |
| Factor of ductility | k_2 | [-] | 1,0 | | | |
| DX-I FAST ETA 1, stainless steel A4, HCR | | | | | | |
| Steel failure without lever arm, Installation type V | | | | | | |
| Characteristic shear resistance | $V_{Rk,s}$ | [kN] | 5,7 | 9,2 | 10,6 | 23,6 |
| Partial safety factor | γ_{Ms} | [-] | 1,25 | | | |
| Steel failure without lever arm, Installation type D | | | | | | |
| Characteristic shear resistance | $V_{Rk,s}$ | [kN] | 7,3 | 7,6 | 9,7 | 29,6 |
| Partial safety factor | γ_{Ms} | [-] | 1,25 | | | |
| Steel failure with lever arm, Installation type V | | | | | | |
| Characteristic bending resistance | $M^0_{Rk,s}$ | [Nm] | 10,7 | 26,2 | 52,3 | 91,6 |
| Partial safety factor | γ_{Ms} | [-] | 1,56 | | | |
| Steel failure with lever arm, Installation type D | | | | | | |
| Characteristic bending resistance | $M^0_{Rk,s}$ | [Nm] | 28,2 | 44,3 | 69,9 | 191,2 |
| Partial safety factor | γ_{Ms} | [-] | 1,25 | | | |
| Factor of ductility | k_2 | [-] | 1,0 | | | |
| Concrete pry-out failure | | | | | | |
| Factor k acc. ETAG 001, Annex C or k_3 acc. CEN/TS 1992-4 | $k_{(3)}$ | [-] | 1,5 | 1,5 | 2,0 | 2,0 |
| Concrete edge failure | | | | | | |
| Effective length of anchor in shear loading | l_f | [mm] | 45 | 58 | 65 | 80 |
| Effective diameter of anchor | d_{nom} | [mm] | 8 | 10 | 12 | 16 |

Ter Laare Wedge Anchor DX-I FAST ETA 1

Performance

Characteristic values for shear loads, **DX-I FAST ETA 1**, cracked and non-cracked concrete, static and quasi-static action, design method A according to ETAG 001, Annex C or CEN/TS 1992-4

Annex C12

Table C13: Characteristic values for tension and shear load under fire exposure, DX-I FAST ETA 1, cracked and non-cracked concrete C20/25 to C50/60, design acc. to TR 020 or CEN/TS 1992-4, Annex D

| Anchor size | | M6 | M8 | M10 | M12 | | |
|--|------|-----------------|------|-----|-----|------|------|
| Tension load | | | | | | | |
| Steel failure | | | | | | | |
| Steel zinc plated | | | | | | | |
| Characteristic resistance | R30 | $N_{Rk,s,fi}$ | [kN] | 0,7 | 1,4 | 2,5 | 3,7 |
| | R60 | | | 0,6 | 1,2 | 2,0 | 2,9 |
| | R90 | | | 0,5 | 0,9 | 1,5 | 2,2 |
| | R120 | | | 0,4 | 0,8 | 1,3 | 1,8 |
| Stainless steel A4, HCR | | | | | | | |
| Characteristic resistance | R30 | $N_{Rk,s,fi}$ | [kN] | 2,9 | 5,4 | 8,7 | 12,6 |
| | R60 | | | 1,9 | 3,8 | 6,3 | 9,2 |
| | R90 | | | 1,0 | 2,1 | 3,9 | 5,7 |
| | R120 | | | 0,5 | 1,3 | 2,7 | 4,0 |
| Shear load | | | | | | | |
| Steel failure without lever arm | | | | | | | |
| Steel zinc plated | | | | | | | |
| Characteristic resistance | R30 | $V_{Rk,s,fi}$ | [kN] | 0,7 | 1,4 | 2,5 | 3,7 |
| | R60 | | | 0,6 | 1,2 | 2,0 | 2,9 |
| | R90 | | | 0,5 | 0,9 | 1,5 | 2,2 |
| | R120 | | | 0,4 | 0,8 | 1,3 | 1,8 |
| Stainless steel A4, HCR | | | | | | | |
| Characteristic resistance | R30 | $V_{Rk,s,fi}$ | [kN] | 2,9 | 5,4 | 8,7 | 12,6 |
| | R60 | | | 1,9 | 3,8 | 6,3 | 9,2 |
| | R90 | | | 1,0 | 2,1 | 3,9 | 5,7 |
| | R120 | | | 0,5 | 1,3 | 2,7 | 4,0 |
| Steel failure with lever arm | | | | | | | |
| Steel zinc plated | | | | | | | |
| Characteristic resistance | R30 | $M^0_{Rk,s,fi}$ | [Nm] | 0,5 | 1,4 | 3,3 | 5,7 |
| | R60 | | | 0,4 | 1,2 | 2,6 | 4,6 |
| | R90 | | | 0,4 | 0,9 | 2,0 | 3,4 |
| | R120 | | | 0,3 | 0,8 | 1,6 | 2,8 |
| Stainless steel A4, HCR | | | | | | | |
| Characteristic resistance | R30 | $M^0_{Rk,s,fi}$ | [Nm] | 2,2 | 5,5 | 11,2 | 19,6 |
| | R60 | | | 1,5 | 3,9 | 8,1 | 14,3 |
| | R90 | | | 0,7 | 2,2 | 5,1 | 8,9 |
| | R120 | | | 0,4 | 1,3 | 3,5 | 6,2 |

The characteristic resistance for pull-out failure, concrete cone failure, concrete pry-out failure and concrete edge failure can be designed according to TR020 / CEN/TS 1992-4.

Ter Laare Wedge Anchor DX-I FAST ETA 1

Performance

Characteristic values for tension and shear loads under fire exposure, **DX-I FAST ETA 1**, cracked and non-cracked concrete C20/25 to C50/60, design acc. to TR 020 or CEN/TS 1992-4, Annex D

Annex C13

Table C14: Displacements under tension load, DX-I FAST ETA 1

| Anchor size | | M6 | M8 | M10 | M12 |
|--------------------------------------|-------------------------|-----|-----|-----|------|
| Tension load in cracked concrete | N [kN] | 2,0 | 3,6 | 4,8 | 8,0 |
| Displacements | δ_{N0} [mm] | 0,6 | 0,6 | 0,8 | 1,0 |
| | $\delta_{N\infty}$ [mm] | 0,8 | 0,8 | 1,2 | 1,4 |
| Tension load in non-cracked concrete | N [kN] | 4,8 | 6,4 | 8,0 | 12,0 |
| Displacements | δ_{N0} [mm] | 0,4 | 0,5 | 0,7 | 0,8 |
| | $\delta_{N\infty}$ [mm] | 0,8 | 0,8 | 1,2 | 1,4 |

Table C15: Displacements under shear load, DX-I FAST ETA 1

| Anchor size | | M6 | M8 | M10 | M12 |
|--|-------------------------|-----|-----|-----|------|
| Shear load in cracked and non-cracked concrete | V [kN] | 4,2 | 5,3 | 6,2 | 16,9 |
| Displacements | δ_{V0} [mm] | 2,8 | 2,9 | 2,5 | 3,6 |
| | $\delta_{V\infty}$ [mm] | 4,2 | 4,4 | 3,8 | 5,3 |

Ter Laare Wedge Anchor DX-I FAST ETA 1

Performance
Displacements under tension load and under shear load

Annex C14