

Approval body for construction products  
and types of construction

Bautechnisches Prüfamt

An institution established by the Federal and  
Laender Governments



## European Technical Assessment

ETA-07/0025  
of 9 December 2016

English translation prepared by DIBt - Original version in German language

### General Part

Technical Assessment Body issuing the  
European Technical Assessment:

Deutsches Institut für Bautechnik

Trade name of the construction product

fischer High-Performance Anchor FH II, FH II-I

Product family  
to which the construction product belongs

Torque-controlled expansion anchor  
for use in concrete

Manufacturer

fischerwerke GmbH & Co. KG  
Klaus-Fischer-Straße 1  
72178 Waldachtal  
DEUTSCHLAND

Manufacturing plant

fischerwerke

This European Technical Assessment  
contains

22 pages including 3 annexes which form an integral part  
of this assessment

This European Technical Assessment is  
issued in accordance with Regulation (EU)  
No 305/2011, on the basis of

Guideline for European technical approval of "Metal  
anchors for use in concrete", ETAG 001 Part 2: "Torque  
controlled expansion anchors", April 2013,  
used as European Assessment Document (EAD)  
according to Article 66 Paragraph 3 of Regulation (EU)  
No 305/2011.

The European Technical Assessment is issued by the Technical Assessment Body in its official language. Translations of this European Technical Assessment in other languages shall fully correspond to the original issued document and shall be identified as such.

Communication of this European Technical Assessment, including transmission by electronic means, shall be in full. However, partial reproduction may only be made with the written consent of the issuing Technical Assessment Body. Any partial reproduction shall be identified as such.

This European Technical Assessment may be withdrawn by the issuing Technical Assessment Body, in particular pursuant to information by the Commission in accordance with Article 25(3) of Regulation (EU) No 305/2011.

## Specific Part

### 1 Technical description of the product

The Fischer High-Performance Anchor FH II, FH II-I is an anchor made of galvanised steel (sizes with external diameter 10, 12, 15, 18, 24, 28 and 32, sizes with internal thread 12/M6 I, 12/M8 I, 15/M10 I and 15/M12 I) or stainless steel (sizes with external diameter 10, 12, 15, 18 and 24, sizes with internal thread 12/M6 I, 12/M8 I, 15/M10 I and 15/M12 I) which is placed into a drilled hole and anchored by torque-controlled expansion.

The product description is given in Annex A.

### 2 Specification of the intended use in accordance with the applicable European Assessment Document

The performances given in Section 3 are only valid if the anchor is used in compliance with the specifications and conditions given in Annex B.

The verifications and assessment methods on which this European Technical Assessment is based lead to the assumption of a working life of the anchor of at least 50 years. The indications given on the working life cannot be interpreted as a guarantee given by the producer, but are to be regarded only as a means for choosing the right products in relation to the expected economically reasonable working life of the works.

### 3 Performance of the product and references to the methods used for its assessment

#### 3.1 Mechanical resistance and stability (BWR 1)

Essential characteristic	Performance
Characteristic resistance for static and quasi static	See Annex C 1 to C 4
Characteristic resistance for seismic performance categories C1	See Annex C 7
Displacements under tension and shear loads	See Annex C 7 and C 8

#### 3.2 Safety in case of fire (BWR 2)

Essential characteristic	Performance
Reaction to fire	Anchorage satisfy requirements for Class A1
Resistance to fire	See Annex C 5 and C 6

#### 3.3 Safety in use (BWR 4)

The essential characteristics regarding Safety in use are included under the Basic Works Requirement Mechanical resistance and stability.

English translation prepared by DIBt

**4 Assessment and verification of constancy of performance (AVCP) system applied, with reference to its legal base**

In accordance with guideline for European technical approval ETAG 001, April 2013, used as European Assessment Document (EAD) according to Article 66 Paragraph 3 of Regulation (EU) No 305/2011, the applicable European legal act is: [96/582/EC].

The system to be applied is: 1

**5 Technical details necessary for the implementation of the AVCP system, as provided for in the applicable European Assessment Document**

Technical details necessary for the implementation of the AVCP system are laid down in the control plan deposited at Deutsches Institut für Bautechnik.

Issued in Berlin on 9 December 2016 by Deutsches Institut für Bautechnik

Andreas Kummerow  
p.p. Head of Department

*beglaubigt:*  
Baderschneider

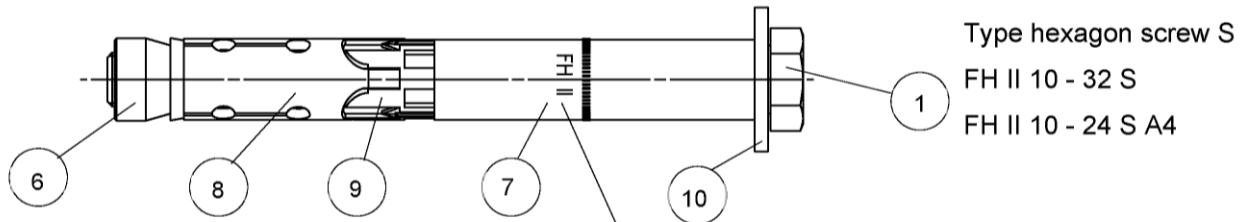

Marking: Identifying mark of the producer, anchor identity nominal drill hole diameter / max. thickness of fixture e. g.  FH II 15/25 A4

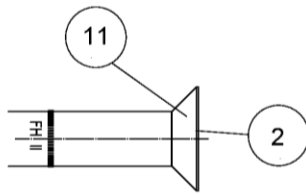

Type countersunk screw **SK**  
FH II 10 - 18 SK  
FH II 10 - 18 SK A4

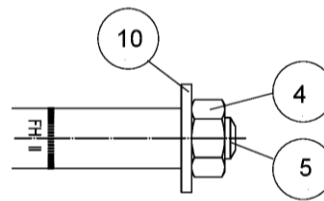

Type hexagon nut **B**  
FH II 10 - 32 B  
FH II 10 - 24 B A4

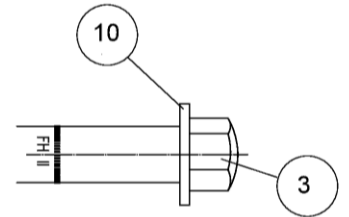

Type cap nut **H**  
FH II 10 - 24 H  
FH II 10 - 24 H A4

- 1 Hexagon screw
- 2 Countersunk screw
- 3 Cap nut
- 4 Hexagon nut

- 5 Threaded rod
- 6 Cone nut
- 7 Distance sleeve
- 8 Expansion sleeve

- 9 Plastic sleeve
- 10 Washer
- 11 Conical washer

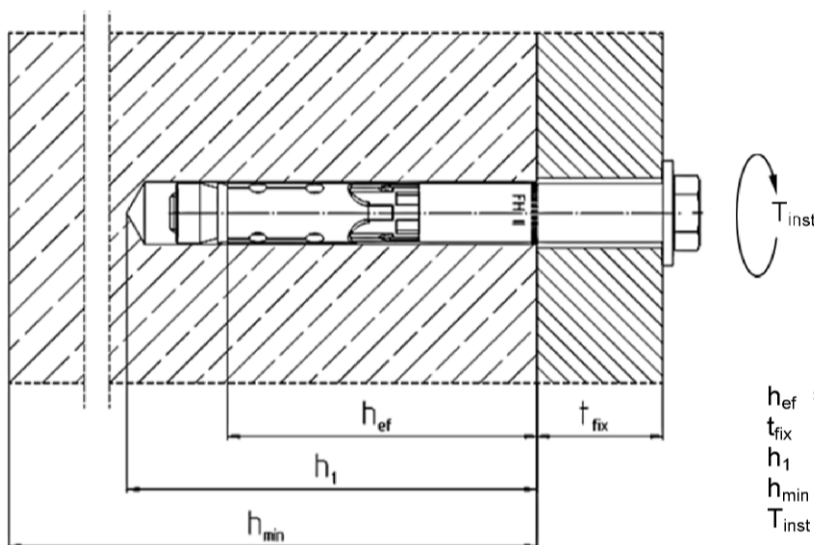

$h_{ef}$  = Effective anchorage depth  
 $t_{fix}$  = Thickness of fixture  
 $h_1$  = Drill hole depth  
 $h_{min}$  = Minimal member thickness  
 $T_{inst}$  = Installation torque

fischer High-Performance Anchor FH II, FH II-I

**Product description**  
Installed condition and Anchor types FH II, FH II A4

**Annex A 1**

FH II 12 M6 I (A4)  
FH II 12 M8 I (A4)  
FH II 15 M10 I (A4)  
FH II 15 M12 I (A4)

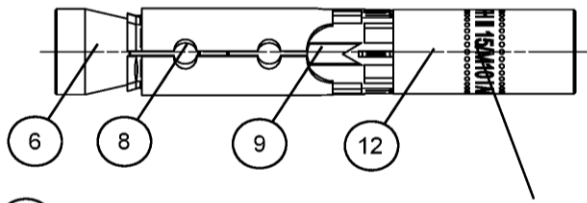

- 6 Cone nut
- 8 Expansion sleeve
- 9 Plastic sleeve
- 12 Internal thread bolt

Marking: Identifying mark of the producer, anchor identity  
nominal drill hole diameter / size of internal thread  
e. g. FH II 15/M12 I A4

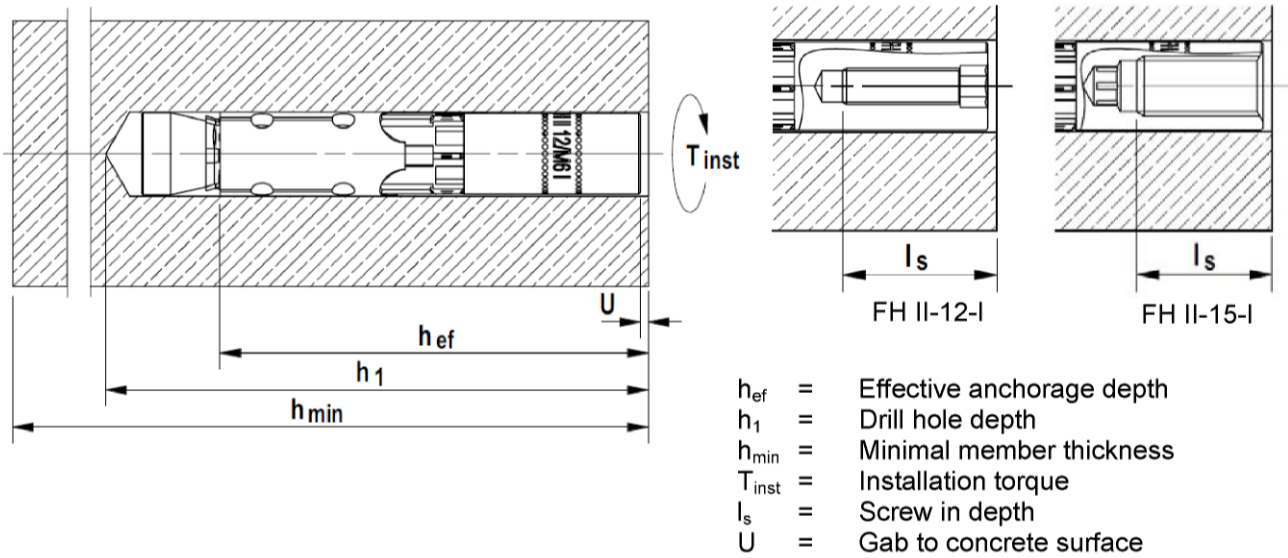

Example of possible Applications FH II-I and FH II-I A4

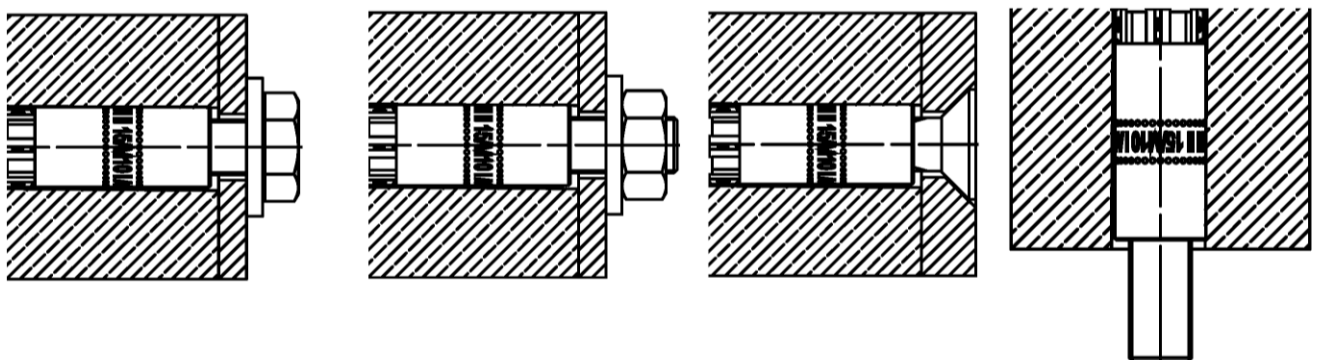

fischer High-Performance Anchor FH II, FH II-I

**Product description**  
Installed condition and Anchor types FH II-I, FH II-I A4

**Annex A 2**

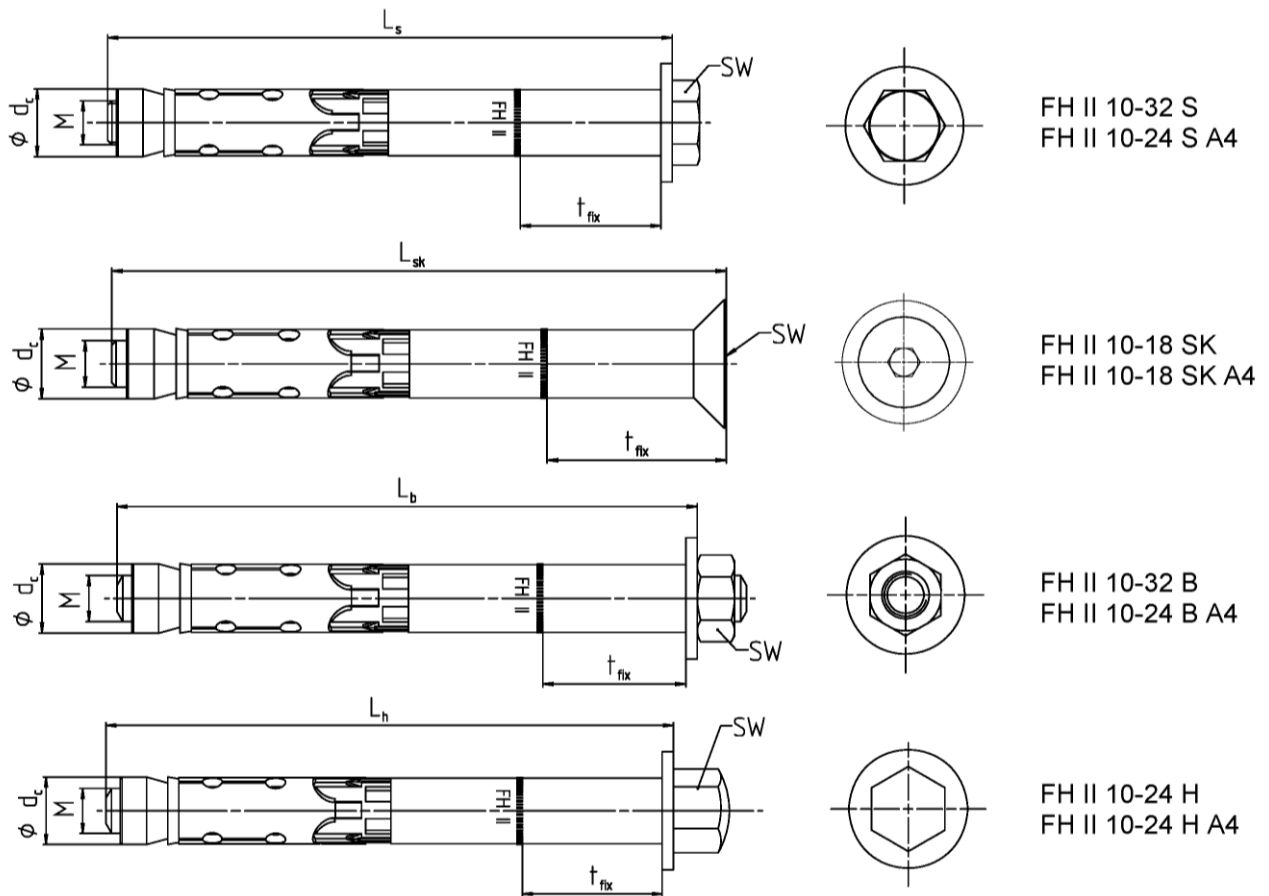

**Table A1:** Anchor Dimensions [mm] FH II and FH II A4

Anchor type FH II S, SK, B, H and FH II S, SK, B, H A4			FH II 10	FH II 12	FH II 15	FH II 18	FH II 24	FH II 28	FH II 32
Thread	M	=	6	8	10	12	16	20	24
Diameter conical nut	d <sub>c</sub>	=	10	12	14,8	17,8	23,7	27,5	31,5
Wrench size SW FH II	FH II S, B	=	10	13	17	19	24	30	36
	FH II SK <sup>1)</sup>		4	5	6	8	-	-	-
	FH II H		13	17	17	19	24	-	-
Wrench size SW FH II A4	FH II S, B, H A4	=	10	13	17	19	24	-	-
	FH II SK A4 <sup>1)</sup>		4	5	6	8	-	-	-
t <sub>fix</sub> FH II + FH II A4 S, B, H	min		0	0	0	0	0	0	0
t <sub>fix, red</sub> FH II SK + FH II SK A4 <sup>2)</sup>	min	=	5	6	6	8	-	-	-
t <sub>fix</sub> FH II + FH II A4	max		250	250	300	350	400	500	500
Length of screw / bolt	L <sub>s</sub> , L <sub>h</sub> , L <sub>b</sub> (- t <sub>fix</sub> )	≥	49	74	89	99	124	149	174
Length of countersunk screw	L <sub>sk</sub> (- t <sub>fix</sub> )	≥	54	79	95	107	-	-	-

<sup>1)</sup> Internal hexagon

<sup>2)</sup> The influence of the thickness of fixture to the characteristic resistance for shear loads, steel failure without lever arm is taken into account, see tables C3 and C4

fischer High-Performance Anchor FH II, FH II-I

**Product description**  
Anchor types and dimensions FH II, FH II A4

**Annex A 3**



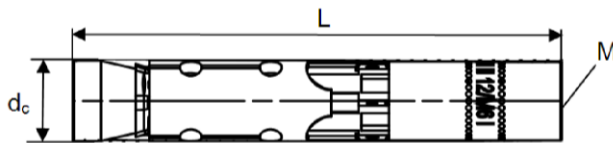

**Table A2:** Anchor Dimensions [mm] FH II-I and FH II-I A4

Anchor type FH II-I and FH II-I A4			FH II 12/M6 I	FH II 12/M8 I	FH II 15/M10 I	FH II 15/M12 I
Thread	M	=	6	8	10	12
Diameter conical nut	d <sub>c</sub>	=	12	12	14,8	14,8
Wrench size internal hexagon		=	6	8	6	8
Anchor length	L	=	77,5	77,5	90	90

**Table A3:** Material FH II and FH II A4

Nb.	Designation	FH II	FH II A4
1	Hexagon screw	Steel class 8.8; EN ISO 898-1:2013 <sup>1)</sup>	Strength class ≥ 70 EN ISO 3506:2010
2	Countersunk screw	Steel class 8.8; EN ISO 898-1:2013 <sup>1)</sup>	
3	Cap nut	Steel class 8 <sup>1)</sup>	
4	Hexagon nut	Steel class 8 <sup>1)</sup>	
5	Threaded rod	Steel f <sub>uk</sub> ≥ 800 N/mm <sup>2</sup> ; f <sub>yk</sub> ≥ 640 N/mm <sup>2</sup> <sup>1)</sup>	
6	Cone nut	Steel EN 10277:2008 <sup>1)</sup>	
7	Distance sleeve	Steel EN 10305:2016 <sup>1)</sup>	EN 10088:2014
8	Expansion sleeve	Steel EN 10139:2016/ EN 10277:2008 <sup>1)</sup>	EN 10088:2014
9	Plastic sleeve	ABS (plastic)	
10	Washer	Steel EN 10139:2016 <sup>1)</sup>	EN 10088:2014
11	Conical washer	Steel EN 10277:2008 <sup>1)</sup>	EN 10088:2014

<sup>1)</sup> Galvanised according to EN ISO 4042:2001, ≥ 5 µm

**Table A4:** Material FH II-I and FH II-I A4

Nb.	Designation	FH II-I	FH II-I A4
6	Cone nut	Steel EN 10277:2008 <sup>1)</sup>	Strength class ≥ 70 EN ISO 3506:2010
8	Expansion sleeve	Steel EN 10139:2016 / EN 10277:2008 <sup>1)</sup>	EN 10088:2014
9	Plastic sleeve	ABS (plastic)	
12	Internal thread bolt	Steel EN 10277:2008 <sup>1)</sup> f <sub>uk</sub> ≥ 750 N/mm <sup>2</sup> , f <sub>yk</sub> ≥ 600 N/mm <sup>2</sup>	EN 10088:2014 f <sub>uk</sub> ≥ 750 N/mm <sup>2</sup> , f <sub>yk</sub> ≥ 600 N/mm <sup>2</sup>
	Requirements for fixing elements	Steel strength class 5.8, 6.8 or 8.8 EN ISO 898-1:2013 <sup>1)</sup>	Steel strength class A50, A70 or A80 EN ISO 3506:2010 1.4362, 1.4401, 1.4404, 1.4571, 1.4529

<sup>1)</sup> Galvanised according to EN ISO 4042:2001, ≥ 5 µm

fischer High-Performance Anchor FH II, FH II-I

**Product description**  
Anchor types and dimensions FH II-I, FH II I-A4  
Materials

**Annex A 4**



### Specifications of intended use

#### Anchorage subject to:

Standard anchorage depth	✓						
High Performance Anchor FH II, FH II A4	10	12	15	18	24	28	32
High Performance Anchor FH II-I, FH II-I A4	-	12	15	-			
Static and quasi-static action load	✓						
Cracked and uncracked concrete	✓						
Fire exposure	✓						
Seismic action for Performance Category C1	-	S, B, H, SK	S, B, H, SK	S, B, H, SK	S, B, H	S, B	S, B

#### Base materials:

- Reinforced and unreinforced normal weight concrete (cracked and uncracked) according to EN 206-1:2000
- Strength classes C20/25 to C50/60 according to EN 206-1:2000

#### Use conditions (Environmental conditions):

- Structures subject to dry internal conditions (FH II, FH II A4, FH II-I, FH II-I A4)
- Structures subject to external atmospheric exposure (including industrial and marine environment) and to permanently damp internal condition, if no particular aggressive conditions exist (FH II A4, FH II-I A4)

Note: Particular aggressive conditions are e.g. permanent, alternating immersion in seawater or the splash zone of seawater, chloride atmosphere of indoor swimming pools or atmosphere with extreme chemical pollution (e.g. in desulphurization plants or road tunnels where de-icing materials are used)

#### Design:

- Anchorages are to be designed under the responsibility of an engineer experienced in anchorages and concrete work
- Verifiable calculation notes and drawings are to be prepared taking account of the loads to be anchored. The position of the anchor is indicated on the design drawings (e.g. position of the anchor relative to reinforcement or to supports, etc.)
- Anchorages under static or quasi-static actions are to be designed in accordance with (please choose the relevant design method):
  - ETAG 001, Annex C, design method A, Edition August 2010 or
  - CEN/TS 1992-4:2009, design method A
- Anchorages under seismic actions (cracked concrete) are to be designed in accordance with:
  - EOTA Technical Report TR 045, Edition February 2013
  - Anchorages shall be positioned outside of critical regions (e.g. plastic hinges) of the concrete structure
  - Fastenings in stand-off installation or with a grout layer under seismic action are not allowed
- Anchorages under fire exposure are to be designed in accordance with:
  - EOTA Technical Report TR 020, Edition May 2004
  - CEN/TS 1992-4:2009, Annex D
  - It must be ensured that local spalling of the concrete cover does not occur

#### Installation:

- Anchor installation carried out by appropriately qualified personnel and under the supervision of the person responsible for technical matters of the site
- Hammer or hollow drilling according to Annex B5 and B6
- In case of aborted hole: New hole must be drilled at a minimum distance of twice the depth of the aborted hole or closer, if the hole is filled with a high strength mortar and only if the hole is not in the direction of the oblique tensile or shear load

fischer High-Performance Anchor FH II, FH II-I

**Intended use**  
Specifications

**Annex B 1**

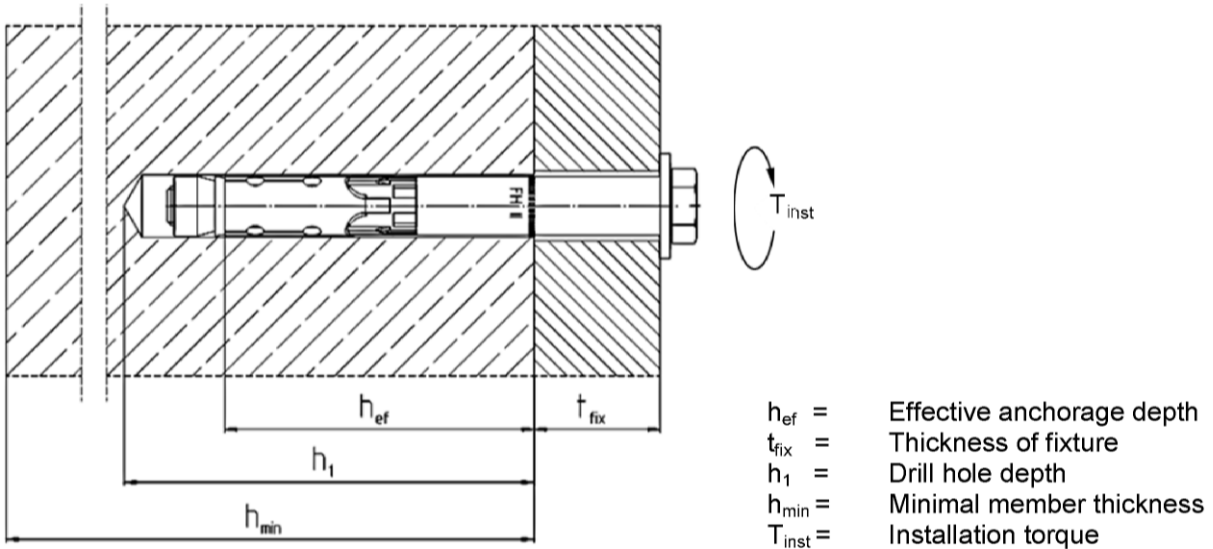

**Table B1:** Installation parameters FH II and FH II A4

Anchor type FH II S, SK, B, H and FH II S, SK, B, H A4		FH II 10	FH II 12	FH II 15	FH II 18	FH II 24	FH II 28	FH II 32	
Nominal drill hole Diameter	$d_0 = [mm]$	10	12	15	18	24	28	32	
Maximum diameter of drill bit	$d_{cut} \leq [mm]$	10,45	12,50	15,50	18,50	24,55	28,55	32,70	
Depth of drill hole	$h_1 \geq [mm]$	55	80	90	105	125	155	180	
Diameter of clearance hole	$d_f \leq [mm]$	12	14	17	20	26	31	35	
Diameter of counter sunk	FH II SK	18	22	25	32	-	-	-	
Depth of counter sunk, 90°	FH II SK A4	5,0	5,8	5,8	8,0	-	-	-	
Required installation torque	FH II S	$T_{inst} = [Nm]$	10	22,5	40	80	160	180	200
	FH II B		10	17,5	38	80	120	180	200
	FH II H		10	22,5	40	80	90	-	-
	FH II SK		10	22,5	40	80	-	-	-
	FH II S, B, H A4		15	25	40	100	160	-	-
	FH II SK A4		10	25	40	100	-	-	-

fischer High-Performance Anchor FH II, FH II-I

**Intended Use**  
Installation instructions FH II, FH II A4

**Annex B 2**

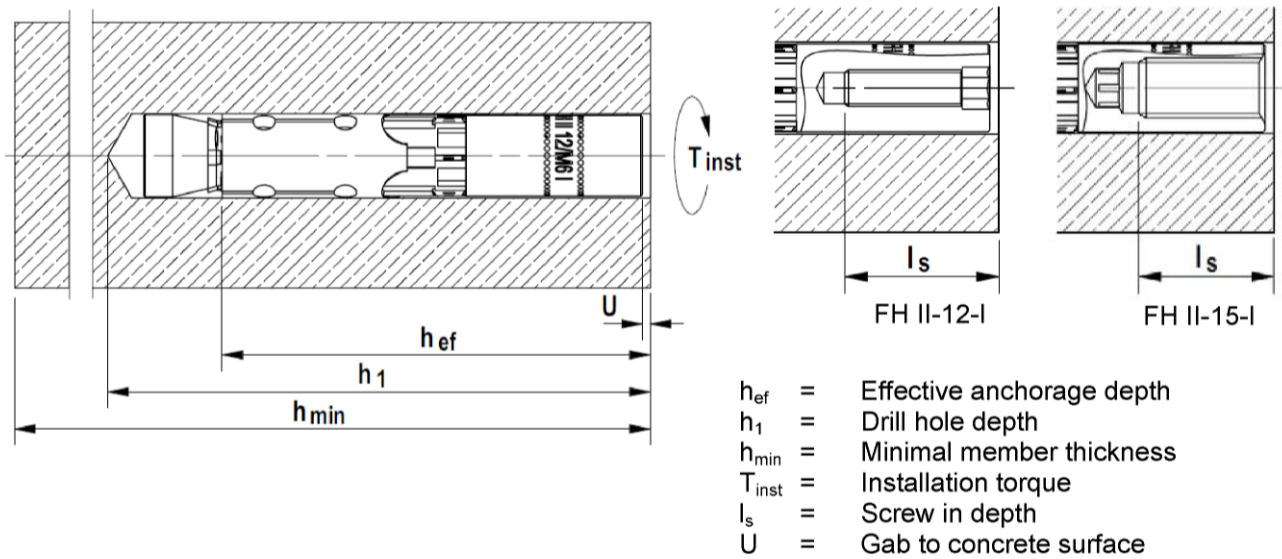

**Table B2:** Installation parameters FH II-I and FH II-I A4

Anchor type FH II-I and FH II-I A4	FH II 12/M6 I	FH II 12/M8 I	FH II 15/M10 I	FH II 15/M12 I
Nominal drill hole diameter $d_0 =$ [mm]	12		15	
Maximum diameter of drill bit $d_{cut} \leq$ [mm]	12,50		15,50	
Depth of drill hole $h_1 \geq$ [mm]	85		95	
Diameter of clearance hole $d_f \leq$ [mm]	7	9	12	14
Required gap after torquing <sup>1)</sup> $U =$ [mm]	3-5 mm			
Required installation torque <sup>1)</sup> $T_{inst} =$ [Nm]	15		25	
Minimum screw in length $l_s \geq$ [mm]	11+U	13+U	10+U	12+U
Maximum screw in length $l_s \leq$ [mm]	20+U			
Maximum torque on fixture in combination with screws and threaded rods strength class $\geq 5.8$ and $\geq A50$ $T_{max} \leq$ [Nm]	3	8	15	20

<sup>1)</sup> Only one of both requirements has to be fulfilled

fischer High-Performance Anchor FH II, FH II-I

**Intended Use**  
Installation instructions FH II-I, FH II-I A4

**Annex B 3**

**Table B3:** Minimum thickness of concrete member, minimum spacing and minimum edge distances FH II, FH II A4

Anchor type FH II S, SK, B, H and FH II S, SK, B, H A4		FH II 10	FH II 12	FH II 15	FH II 18	FH II 24	FH II 28	FH II 32
Min. member thickness	$h_{min}$ [mm]	80	120	140	160	200	250	300
Minimum spacing, cracked concrete	$s_{min}$ [mm]	40	50	60	70	80	100	120
	for $c \geq$ [mm]	40	80	120	140	180	200	260
Minimum edge distance, cracked concrete	$c_{min}$ [mm]	40	50	60	70	80	100	120
	for $s \geq$ [mm]	40	80	120	160	200	220	280
Minimum spacing, uncracked concrete	$s_{min}$ [mm]	40	60	70	80	100	120	160
	for $c \geq$ [mm]	70	100	100	160	200	220	360
Minimum edge distance, uncracked concrete	$c_{min}$ [mm]	40	60	70	80	100	120	180
	for $s \geq$ [mm]	70	100	140	200	220	240	380

Intermediate values may be calculated by linear interpolation.

**Table B4:** Minimum thickness of concrete member, min. spacing and min. edge distances FH II-I, FH II-I A4

Anchor type FH II-I and FH II-I A4		FH II 12/M6 I FH II 12/M8 I	FH II 15/M10 I FH II 15/M12 I
Min. member thickness	$h_{min}$ [mm]	125	150
Minimum spacing, cracked concrete	$s_{min}$ [mm]	50	60
	for $c \geq$ [mm]	80	120
Minimum edge distance, cracked concrete	$c_{min}$ [mm]	50	60
	for $s \geq$ [mm]	80	120
Minimum spacing, uncracked concrete	$s_{min}$ [mm]	60	70
	for $c \geq$ [mm]	100	100
Minimum edge distance, uncracked concrete	$c_{min}$ [mm]	60	70
	for $s \geq$ [mm]	100	140

Intermediate values may be calculated by linear interpolation.

**Table B5:** Minimum spacings and minimum edge distances of anchors according to **TR 020 and ETAG 001, Annex C** under fire exposure and according to **CEN/TS 1992-4: 2009, Annex D** under fire exposure

Anchor type	FH II 10	FH II 12 FH II 12-I	FH II 15 FH II 15-I	FH II 18	FH II 24	FH II 28	FH II 32
Spacing	$s_{cr,N}$ [mm]	$4 \times h_{ef}$					
	$s_{min}$ [mm]	40	60	70	80	100	125
Edge distance	$c_{cr,n}$ [mm]	$2 \times h_{ef}$					
	$c_{min}$ [mm]	$c_{min} = 2 \times h_{ef}$ , for fire exposure from more than one side $c_{min} \geq 300$ mm					

fischer High-Performance Anchor FH II, FH II-I

**Intended Use**  
Minimum thickness of member, minimum spacings and edge distances  
Minimum spacings and minimum edge distances of anchors



**Annex B 4**

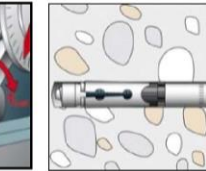
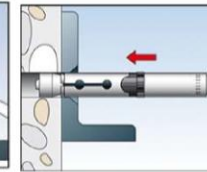
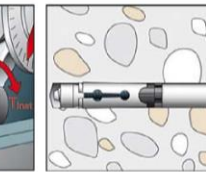
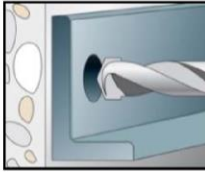
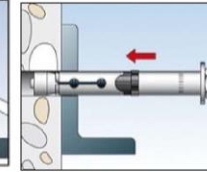
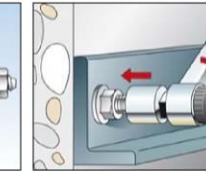
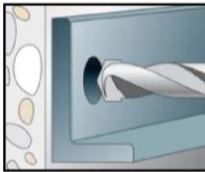
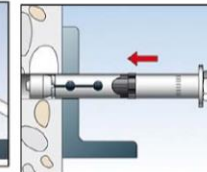
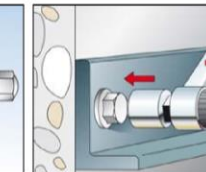

Installation instruction for the fischer high performance anchor  
FH II 10 - FH II 32 and FH II 10 A4 - FH II 24 A4

<b>Hollow drilling</b>		Continue with step 3, 4 and 5			
					
<b>Hammer drilling</b>	Installation instruction FH II 10 - 32 S and FH II 10-24 S A4				
					
	Installation instruction FH II 10 - 18 SK and FH II 10-18 SK A4				
					
	Installation instruction FH II 10 - 32 B and FH II 10-24 B A4				
					
Installation instruction FH II 10 - 24 H and FH II 10-24 H A4					
Step	1	2	3	4	5

Step	Description	
1	Create drill hole with hammer drill	Create drill hole with hollow drill and vacuum cleaner
2	Clean bore hole	-
3	Set anchor	
4	Expand anchor with prescribed installation torque $T_{inst}$	
5	Finished installation	

Types of drills	
Hammer drill	
Hollow drill	

fischer High-Performance Anchor FH II, FH II-I

**Intended Use**  
Installation instructions FH II, FH II A4

**Annex B 5**

Installation instruction for the fischer high performance anchor internal thread  
**FH II-I and FH II-I A4**

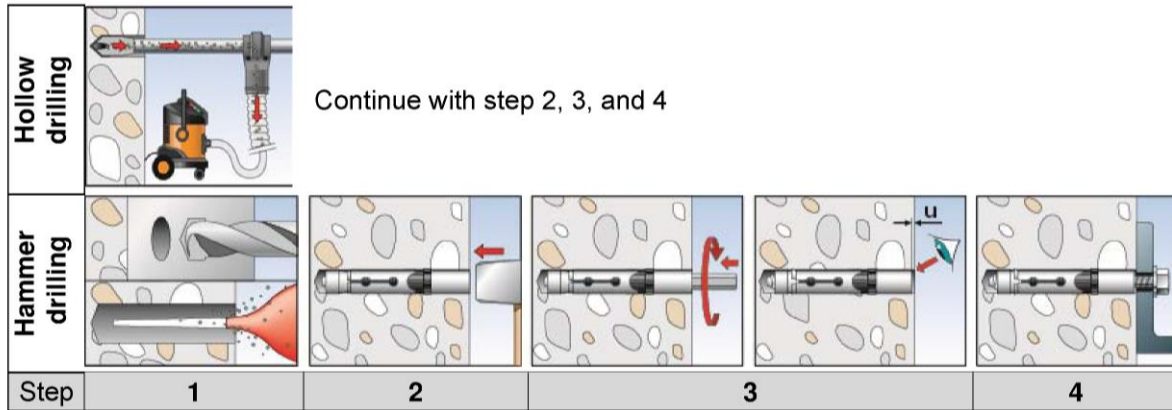

Step	Description	
1	Create drill hole with hammer drill Clean drill hole	Create drill hole with hollow drill and vacuum cleaner
2	Hammering in the anchor flushed with the surface of the concrete	
3	Tightening the anchor. Tightening with the included hexagon in the package is preferred. Other tightening methods are allowed. Tighten the anchor into the concrete until the gap U is 3-5 mm or the installation torque is reached. Only one requirement has to be fulfilled.	
4	Connecting the fixing and the anchor with a fitting fastener. The length of the fastener should be determined depending on the thickness of fixture $t_{fix}$ , admissible tolerances, and available thread length $l_{s,max}$ and $l_{s,min}$ including the gap U. Tightening the screw with the torque $\leq T_{max}$ .	

Types of drills	
Hammer drill	
Hollow drill	

electronic copy of the eta by dibt: eta-07/0025

fischer High-Performance Anchor FH II, FH II-I

**Intended Use**  
Installation instructions FH II-I, FH II I A4

**Annex B 6**

**Table C1:** Characteristic values of **tension** resistance under static and quasi-static action for FH II and FH II A4 (Design method A, according to ETAG 001, Annex C or CEN/TS1992-4:2009)

Anchor type FH II S, SK, B, H and FH II S, SK, B, H A4			FH II 10	FH II 12	FH II 15	FH II 18	FH II 24	FH II 28	FH II 32
<b>Steel failure</b>									
FH II	$N_{Rk,s}$	[kN]	16,1	29,3	46,4	67,4	125,3	195,8	282,0
FH II A4	$N_{Rk,s}$	[kN]	14,1	25,6	40,6	59,0	109,7	-	-
Partial safety factor	$\gamma_{Ms}$	<sup>1)</sup>	1,5						
<b>Pullout failure</b>									
cracked concrete FH II and FH II A4	$N_{Rk,p}$	[kN] C20/25	7,5	12	16	25	2)		
uncracked concrete FH II	$N_{Rk,p}$	[kN] C20/25	2)						
uncracked concrete FH II A4	$N_{Rk,p}$	[kN] C20/25	2)	20	2)			-	
Increasing factors for $N_{Rk,p}$ for cracked and uncracked concrete	$\psi_c$	C25/30	1,10						
		C30/37	1,22						
		C35/45	1,34						
		C40/50	1,41						
		C45/55	1,48						
		C50/60	1,55						
Installation safety factor	$\gamma_2$	<sup>3)</sup> = $\gamma_{inst}$ <sup>4)</sup>	1,0						
<b>Concrete cone failure and splitting failure</b>									
Effective anchorage depth	$h_{ef}$	[mm]	40	60	70	80	100	125	150
Factor for uncracked concrete	$k_{ucr}$	<sup>4)</sup> [-]	10,1						
Factor for cracked concrete	$k_{cr}$	<sup>4)</sup> [-]	7,2						
Spacing	$s_{cr,N}$	[mm]	120	180	210	240	300	375	450
Edge distance	$c_{cr,N}$	[mm]	60	90	105	120	150	187,5	225
Spacing (splitting)	$s_{cr,sp}$	[mm]	190	300	320	340	380	480	570
Edge distance (splitting)	$c_{cr,sp}$	[mm]	95	150	160	170	190	240	285
Installation safety factor	$\gamma_2$	<sup>3)</sup> = $\gamma_{inst}$ <sup>4)</sup>	1,0						

<sup>1)</sup> In absence of other national regulations

<sup>2)</sup> Pullout failure not relevant

<sup>3)</sup> Parameter relevant for design according to ETAG 001, Annex C

<sup>4)</sup> Parameter relevant for design according to CEN/TS 1992-4:2009

fischer High-Performance Anchor FH II, FH II-I

**Performances**

Characteristic values of resistance under tension loads for FH II and FH II A4

**Annex C 1**



**Table C2:** Characteristic values of **tension** resistance under static and quasi-static action for FH II-I and FH II-I A4 (Design method A, according to **ETAG 001, Annex C** or **CEN/TS 1992-4:2009**)

Anchor type FH II-I and FH II-I A4		FH II 12/M6 I	FH II 12/M8 I	FH II 15/M10 I	FH II 15/M12 I
<b>Steel failure</b>					
<b>Anchor in combination with screw / threaded rod of galvanised steel complying with DIN EN ISO 898</b>					
Strength class 5.8	$N_{Rk,s}$ [kN]	10	19	29	43
Strength class 6.8	$N_{Rk,s}$ [kN]	12	23	35	44
Strength class 8.8	$N_{Rk,s}$ [kN]	16	27	44	44
Partial safety factor	$\gamma_{Ms}^{1)}$	1,5			
<b>Anchor in combination with screw / threaded rod of stainless steel complying with DIN EN ISO 3506</b>					
Screw/thread strength class A50	$N_{Rk,s}$ [kN]	10	19	29	43
Partial safety factor	$\gamma_{Ms}^{1)}$	2,86			
Screw/thread strength class A70	$N_{Rk,s}$ [kN]	14	26	41	54
Partial safety factor	$\gamma_{Ms}^{1)}$	1,87			
Screw/thread strength class A80	$N_{Rk,s}$ [kN]	16	29	46	46
Partial safety factor	$\gamma_{Ms}^{1)}$	1,60			
<b>Pullout failure</b>					
cracked concrete	$N_{Rk,p}$ [kN] C20/25	9		12	
uncracked concrete	$N_{Rk,p}$ [kN] C20/25	20		2)	
Increasing factors for $N_{Rk,p}$ for cracked and uncracked concrete	$\psi_c$ C25/30			1,10	
	C30/37			1,22	
	C35/45			1,34	
	C40/50			1,41	
	C45/55			1,48	
	C50/60			1,55	
Installation safety factor	$\gamma_2^{3)} = \gamma_{inst}^{4)}$	1,0			
<b>Concrete cone failure and splitting failure</b>					
Effective anchorage depth	$h_{ef}$ [mm]	60		70	
Factor for uncracked concrete	$k_{ucr}^{4)}$ [-]			10,1	
Factor for cracked concrete	$k_{cr}^{4)}$ [-]			7,2	
Spacing	$s_{cr,N}$ [mm]	180		210	
Edge distance	$c_{cr,N}$ [mm]	90		105	
Spacing (splitting)	$s_{cr,sp}$ [mm]	300		320	
Edge distance (splitting)	$c_{cr,sp}$ [mm]	150		160	
Installation safety factor	$\gamma_2^{3)} = \gamma_{inst}^{4)}$	1,0			

<sup>1)</sup> In absence of other national regulations

<sup>2)</sup> Pullout failure is not decisive

<sup>3)</sup> Parameter relevant for design according to ETAG 001, Annex C

<sup>4)</sup> Parameter relevant for design according to CEN/TS 1992-4:2009

fischer High-Performance Anchor FH II, FH II-I

**Performances**

Characteristic values of resistance under tension loads for FH II-I and FH II-I A4

**Annex C 2**

**Table C3:** Characteristic values of **shear** resistance for **FH II** and **FH II A4** under static and quasi-static action (Design method A, according to **ETAG 001, Annex C** or **CEN/TS 1992-4:2009**)

Anchor type FH II S, SK, B, H and FH II S, SK, B, H A4		FH II 10	FH II 12	FH II 15	FH II 18	FH II 24	FH II 28	FH II 32
<b>Steel failure without lever arm</b>								
FH II S	$V_{Rk,s}$ [kN]	18	33	59	76	146	174	217
FH II B + FH II H	$V_{Rk,s}$ [kN]	16	27	41	62	119	146	169
FH II S A4, FH II B A4, FH II H A4	$V_{Rk,s}$ [kN]	18	28	43	66	119	-	-
FH II SK for $t_{fix}$ standard	$V_{Rk,s}$ [kN]	18	33	59	76	-	-	-
FH II SK A4 for $t_{fix}$ standard	$V_{Rk,s}$ [kN]	18	28	43	66	-	-	-
$t_{fix}$ standard for FH II SK	$t_{fix}$ [mm]	≥10	≥10	≥15	≥15	-	-	-
FH II SK for $t_{fix}$ reduced	$V_{Rk,s}$ [kN]	8	14	23	34	-	-	-
FH II SK A4 for $t_{fix}$ reduced	$V_{Rk,s}$ [kN]	7	13	20	30	-	-	-
$t_{fix}$ reduced for FH II SK	$t_{fix}$ [mm]	<10	<10	<15	<15	-	-	-
Partial safety factor	$\gamma_{Ms}$ <sup>1)</sup>	1,25						
Factor for ductility	$k_2$ <sup>2)</sup>	1,0						
<b>Steel failure with lever arm</b>								
Bending FH II	$M^0_{Rk,s}$ [Nm]	12	30	60	105	266	518	896
Bending FH II A4	$M^0_{Rk,s}$ [Nm]	11	26	52	92	232	-	-
Partial safety factor	$\gamma_{Ms}$ <sup>1)</sup>	1,25						
<b>Concrete pryout failure</b>								
Factor k according to ETAG 001, Annex C or $k_3$ according to CEN/TS 1992-4	$k^{2)}=k_3^{3)}$	1,0	2,0					
<b>Concrete edge failure</b>								
Effective length of anchor	$l_f$ [mm]	40	60	70	80	100	125	150
Effective diameter of anchor	$d_{nom}$ [mm]	10	12	15	18	24	28	32
Installation safety factor	$\gamma_2^{2)} = \gamma_{inst}^{3)}$	1,0						

<sup>1)</sup> In absence of other national regulations

<sup>2)</sup> Parameter relevant for design according to ETAG 001, Annex C

<sup>3)</sup> Parameter relevant for design according to CEN/TS 1992-4:2009

fischer High-Performance Anchor FH II, FH II-I

**Performances**  
Characteristic values of resistance under **shear** loads for FH II and FH II A4

**Annex C 3**

**Table C4:** Characteristic values of **shear** resistance for **FH II-I** and **FH II-I A4** under static and quasi-static action (Design method A, according to **ETAG 001, Annex C** or **CEN/TS 1992-4:2009**)

Anchor type FH II-I and FH II-I A4		FH II 12/M6 I	FH II 12/M8 I	FH II 15/M10 I	FH II 15/M12 I
<b>Steel failure without lever arm</b>					
<b>Anchor in combination with screw / threaded rod of galvanised steel complying with DIN EN ISO 898</b>					
Strength class 5.8	$V_{Rk,s}$ [kN]	5	9	15	21
Strength class 6.8	$V_{Rk,s}$ [kN]	6	11	18	24
Strength class 8.8	$V_{Rk,s}$ [kN]	8	14	23	24
Partial safety factor	$\gamma_{Ms}^{1)}$	1,25			
Factor for ductility	$k_2^{2)}$	1,0			
<b>Anchor in combination with screw / threaded rod of stainless steel complying with DIN EN ISO 3506</b>					
Strength class A50	$V_{Rk,s}$ [kN]	5	9	15	21
Partial safety factor	$\gamma_{Ms}^{1)}$	2,38			
Strength class A70	$V_{Rk,s}$ [kN]	7	13	20	30
Partial safety factor	$\gamma_{Ms}^{1)}$	1,56			
Strength class A80	$V_{Rk,s}$ [kN]	8	15	23	32
Partial safety factor	$\gamma_{Ms}^{1)}$	1,33			
Factor for ductility	$k_2^{2)}$	1,0			
<b>Steel failure with lever arm</b>					
<b>Anchor in combination with screw / threaded rod of galvanised steel complying with DIN EN ISO 898</b>					
Strength class 5.8	$M_{Rk,s}^0$ [Nm]	8	19	37	65
Strength class 6.8	$M_{Rk,s}^0$ [Nm]	9	23	44	78
Strength class 8.8	$M_{Rk,s}^0$ [Nm]	12	30	60	105
Partial safety factor	$\gamma_{Ms}^{1)}$	1,25			
Factor for ductility	$k_2^{2)}$	1,0			
<b>Anchor in combination with screw / threaded rod of stainless steel complying with DIN EN ISO 3506</b>					
Strength class A50	$M_{Rk,s}^0$ [Nm]	8	19	37	65
Partial safety factor	$\gamma_{Ms}^{1)}$	2,38			
Strength class A70	$M_{Rk,s}^0$ [Nm]	11	26	52	92
Partial safety factor	$\gamma_{Ms}^{1)}$	1,56			
Strength class A80	$M_{Rk,s}^0$ [Nm]	12	30	60	105
Partial safety factor	$\gamma_{Ms}^{1)}$	1,33			
Factor for ductility	$k_2^{2)}$	1,0			
<b>Concrete pryout failure</b>					
Factor k according to ETAG 001, Annex C or $k_3$ according to CEN/TS 1992-4	$k^{2)} = k_3^{3)}$	2,0			
<b>Concrete edge failure</b>					
Effective length of anchor under	$l_f$ [mm]	60		70	
Effective diameter of anchor	$d_{nom}$ [mm]	12		15	
Installation safety factor	$\gamma_2^{2)} = \gamma_{inst}^{3)}$	1,0			

<sup>1)</sup> In absence of other national regulations

<sup>2)</sup> Parameter relevant for design according to ETAG 001, Annex C

<sup>3)</sup> Parameter relevant for design according to CEN/TS 1992-4:2009

fischer High-Performance Anchor FH II, FH II-I

**Performances**  
Characteristic values of resistance under **shear** loads for FH II-I and FH II-I A4

**Annex C 4**

**Table C5:** Characteristic values of **tension** resistance under **fire exposure** in cracked and uncracked concrete (Design according to **TR 020** and **ETAG 001**, **Annex C** or **CEN/TS 1992-4: 2009, Annex D**)

Anchor type	R30			R60		
	$N_{Rk,s,fi,30}$ [kN]	$N_{Rk,p,fi,30}$ [kN]	$N_{Rk,c,fi,30}^0$ [kN]	$N_{Rk,s,fi,60}$ [kN]	$N_{Rk,p,fi,60}$ [kN]	$N_{Rk,c,fi,60}^0$ [kN]
FH II 10 (A4)	0,2	1,8	1,8	0,2	1,8	1,8
FH II 12 (A4)	2,0	3,0	5,0	1,3	3,0	5,0
FH II 15 (A4)	3,2	4,0	7,4	2,3	4,0	7,4
FH II 18 (A4)	4,8	6,3	10,3	3,9	6,3	10,3
FH II 24 (A4)	8,9	9,0	18,0	7,3	9,0	18,0
FH II 28	13,9	12,6	31,4	11,3	12,6	31,4
FH II 32	20,0	16,5	49,6	16,3	16,5	49,6
FH II 12/M6 I (A4) 5.8/A50 <sup>1)</sup>	0,1	2,3	5,0	0,1	2,3	5,0
8.8, A70, A80 <sup>1) 2)</sup>	0,2			0,2		
FH II 12/M8 I (A4) 5.8/A50 <sup>1)</sup>	1,3			0,8		
8.8, A70, A80 <sup>1) 2)</sup>	2,0			1,3		
FH II 15/M10 I (A4) 5.8/A50 <sup>1)</sup>	2,0	3,0	7,4	1,4	3,0	7,4
8.8, A70, A80 <sup>1) 2)</sup>	3,2			2,3		
FH II 15/M12 I (A4) 5.8/A50 <sup>1)</sup>	3,0			2,4		
8.8, A70, A80 <sup>1) 2)</sup>	4,8			3,9		
	R90			R120		
	$N_{Rk,s,fi,90}$ [kN]	$N_{Rk,p,fi,90}$ [kN]	$N_{Rk,c,fi,90}^0$ [kN]	$N_{Rk,s,fi,120}$ [kN]	$N_{Rk,p,fi,120}$ [kN]	$N_{Rk,c,fi,120}^0$ [kN]
FH II 10 (A4)	0,1	1,8	1,8	0,1	1,5	1,5
FH II 12 (A4)	0,6	3,0	5,0	0,2	2,4	4,0
FH II 15 (A4)	1,4	4,0	7,4	1,0	3,2	5,9
FH II 18 (A4)	3,0	6,3	10,3	2,6	5,0	8,2
FH II 24 (A4)	5,6	9,0	18,0	4,8	7,2	14,4
FH II 28	8,8	12,6	31,4	7,5	10,1	25,2
FH II 32	12,6	16,5	49,6	10,8	13,2	39,7
FH II 12/M6 I (A4) 5.8/A50 <sup>1)</sup>	0,1	2,3	5,0	0,1	1,8	4,0
8.8, A70, A80 <sup>1) 2)</sup>	0,1			0,1		
FH II 12/M8 I (A4) 5.8/A50 <sup>1)</sup>	0,4			0,1		
8.8, A70, A80 <sup>1) 2)</sup>	0,6			0,2		
FH II 15/M10 I (A4) 5.8/A50 <sup>1)</sup>	0,9	3,0	7,4	0,6	2,4	5,9
8.8, A70, A80 <sup>1) 2)</sup>	1,4			1,0		
FH II 15/M12 I (A4) 5.8/A50 <sup>1)</sup>	1,9			1,6		
8.8, A70, A80 <sup>1) 2)</sup>	3,0			2,6		

<sup>1)</sup> Intermediate values by linear interpolation

<sup>2)</sup> In combination with screw / threaded rod strength class 8.8, A70, A80

In absence of other national regulations the partial safety factor for resistance under fire exposure

$\gamma_{M,fi} = 1,0$  is recommended.

fischer High-Performance Anchor FH II, FH II-I

**Performances**

Characteristic values of **tension** resistance under **fire exposure** in cracked and uncracked concrete

**Annex C 5**

**Table C6:** Characteristic values of **shear resistance** under **fire exposure** in cracked and uncracked concrete (Design according to **TR 020** and **ETAG 001, Annex C** or **CEN/TS 1992-4:2009, Anhang D**)

Anchor type	R30		R60	
	Fire resistance 30 minutes		Fire resistance 60 minutes	
	$V_{Rk,s,fi,30}$ [kN]	$M_{Rk,s,fi,30}^0$ [Nm]	$V_{Rk,s,fi,60}$ [kN]	$M_{Rk,s,fi,60}^0$ [Nm]
FH II 10 (A4)	0,3	0	0,3	0
FH II 12 (A4)	2,0	2	1,3	1
FH II 15 (A4)	3,2	4	2,3	3
FH II 18 (A4)	4,8	7	3,9	6
FH II 24 (A4)	8,9	19	7,3	15
FH II 28	13,9	37	11,3	30
FH II 32	20,0	64	16,3	52
FH II 12/M6 I (A4) 5.8/A50	0,2	0	0,2	0
8.8, A70, A80 <sup>1)</sup>	0,3	0	0,3	0
FH II 12/M8 I (A4) 5.8/A50	1,3	1	0,8	1
8.8, A70, A80 <sup>1)</sup>	2,0	2	1,3	1
FH II 15/M10 I (A4) 5.8/A50	2,0	3	1,4	2
8.8, A70, A80 <sup>1)</sup>	3,2	4	2,3	3
FH II 15/M12 I (A4) 5.8/A50	3,0	4	2,4	4
8.8, A70, A80 <sup>1)</sup>	4,8	7	3,9	6
	R90		R120	
	Fire resistance 90 minutes		Fire resistance 120 minutes	
	$V_{Rk,s,fi,90}$ [kN]	$M_{Rk,s,fi,90}^0$ [Nm]	$V_{Rk,s,fi,120}$ [kN]	$M_{Rk,s,fi,120}^0$ [Nm]
FH II 10 (A4)	0,2	0	0,1	0
FH II 12 (A4)	0,6	1	0,2	0
FH II 15 (A4)	1,4	2	1,0	1
FH II 18 (A4)	3,0	5	2,6	4
FH II 24 (A4)	5,6	12	4,8	10
FH II 28	8,8	23	7,5	20
FH II 32	12,6	40	10,8	34
FH II 12/M6 I (A4) 5.8/A50	0,1	0	0,1	0
8.8, A70, A80 <sup>1)</sup>	0,2	0	0,1	0
FH II 12/M8 I (A4) 5.8/A50	0,4	1	0,1	0
8.8, A70, A80 <sup>1)</sup>	0,6	1	0,2	0
FH II 15/M10 I (A4) 5.8/A50	0,9	2	0,6	1
8.8, A70, A80 <sup>1)</sup>	1,4	3	1,0	1
FH II 15/M12 I (A4) 5.8/A50	1,9	4	1,6	3
8.8, A70, A80 <sup>1)</sup>	3,0	6	2,6	4

<sup>1)</sup> In combination with screw / threaded rod strength class 8.8, A70, A80

**Concrete pryout failure:** In Equation (5.6) of ETAG 001, Annex C, 5.2.3.3, the k-factor for FH II 12-32 is 2,0, respectively 1,0 for FH II 10 and the relevant values of  $N_{Rk,c,fi}^0$  of Table C5 have to be considered in the design.

**Concrete edge failure:** The characteristic resistance  $V_{0Rk,c,fi}$  in concrete C20/25 to C50/60 is determined by:  $V_{0Rk,c,fi} = 0,25 \times V_{0Rk,c}^0$  (R30, R60, R90),  $V_{0Rk,c,fi} = 0,20 \times V_{0Rk,c}^0$  (R120) with  $V_{0Rk,c}^0$  as initial value of the characteristic resistance in cracked concrete C20/25 under normal temperature according to ETAG 001, Annex C, 5.2.3.4.

In absence of other national regulations the partial safety factor for resistance under fire exposure  $\gamma_{M,fi} = 1,0$  is recommended.

fischer High-Performance Anchor FH II, FH II-I

**Performances**

Characteristic values of shear resistance under **fire exposure** in cracked and uncracked concrete

**Annex C 6**



**Table C7:** Characteristic values for seismic action valid for performance category C1 for FH II

		FH II 12	FH II 15	FH II 18	FH II 24	FH II 28	FH II 32
<b>Steel failure</b>							
Anchor type FH II S, SK, B, H	$N_{Rk,s,seis}^0$ [kN]	29,3	46,4	67,4	125,3	195,8	282,0
Anchor type FH II S, SK, B, H	$\gamma_{Ms,seis}^1$ [-]	1,5					
<b>Pullout failure</b>							
Anchor type FH II S, SK, B, H	$N_{Rk,p,seis}^0$ [kN]	12,0	16,0	25,0	36,0	50,3	66,1
Anchor type FH II S, SK, B, H	$\gamma_{Mp,seis}^1$ [-]	1,5					
<b>Steel failure without lever arm</b>							
Anchor type FH II S, SK	$V_{Rk,s,seis}^0$ [kN]	25	41	60	123	141	200
Anchor type FH II B, H	$V_{Rk,s,seis}^0$ [kN]	17	30	46	103	117	169
Anchor type FH II S, SK, B, H	$\gamma_{Ms,seis}^1$ [-]	1,25					

<sup>1)</sup> In absence of other national regulations

**Table C8:** Displacements due to tension loads for FH II and FH II A4

Anchor type FH II S, SK, B, H and FH II S, SK, B, H A4		FH II 10	FH II 12	FH II 15	FH II 18	FH II 24	FH II 28	FH II 32
Tension load cracked concrete	N [kN]	3,6	5,7	7,6	11,9	17,1	24,0	31,5
Corresponding displacements	$\delta_{N0}$ [mm]	1,0	1,0	1,0	1,0	1,0	0,7	0,7
	$\delta_{N\infty}$ [mm]	1,7	1,6	1,6	1,6	1,8	1,3	1,1
Tension load uncracked concrete	N [kN]	6,0	11,2	14,1	17,2	24,0	33,6	44,2
Corresponding displacements	$\delta_{N0}$ [mm]	0,6	1,0	1,0	1,0	1,0	0,3	0,3
	$\delta_{N\infty}$ [mm]	1,7	1,6	1,6	1,6	1,8	1,3	1,1

**Table C9:** Displacements due to tension loads for FH II-I and FH II-I A4

Anchor type FH II-I and FH II-I A4		FH II 12/M6 I FH II 12/M8 I	FH II 15/M10 I FH II 15/M12 I
Tension load cracked concrete	N [kN]	4,3	5,7
Tension load uncracked concrete	N [kN]	9,5	14,1
Corresponding displacements	$\delta_{N0}$ [mm]	1,7	1,9
	$\delta_{N\infty}$ [mm]	2,2	2,9

fischer High-Performance Anchor FH II, FH II-I

**Performances**  
Characteristic values for seismic action valid for performance category C1  
Displacements under tension loads

**Annex C 7**

**Table C10:** Displacements due to shear loads for FH II S and SK <sup>1)</sup>

Anchor type FH II S and FH II SK			FH II 10	FH II 12	FH II 15	FH II 18	FH II 24	FH II 28	FH II 32
Shear load in cracked and uncracked concrete	V	[kN]	10,3	18,9	33,7	43,4	83,4	99,4	124,0
Corresponding displacements	$\delta_{V0}$	[mm]	2,4	2,7	4,4	5,0	7,0	6,0	8,0
	$\delta_{V\infty}$	[mm]	3,6	4,1	6,6	7,5	10,5	9,0	12,0

<sup>1)</sup> Tolerance of clearance hole not included in the displacements

**Table C11:** Displacements due to shear loads for FH II B and H <sup>1)</sup>

Anchor type: FH II B and FH II H			FH II 10	FH II 12	FH II 15	FH II 18	FH II 24	FH II 28	FH II 32
Shear load in cracked and uncracked concrete	V	[kN]	8,9	15,4	23,4	35,4	68,0	83,4	96,6
Corresponding displacements	$\delta_{V0}$	[mm]	2,2	2,3	3,0	5,0	7,0	5,0	5,0
	$\delta_{V\infty}$	[mm]	3,3	3,5	4,5	7,5	10,5	7,5	7,5

<sup>1)</sup> Tolerance of clearance hole not included in the displacements

**Table C12:** Displacements due to shear loads for FH II S A4, FH II SK A4, FH II B A4 and FH II H A4 <sup>1)</sup>

Anchor type: FH II S A4, FH II SK A4, FH II B A4, FH II H A4			FH II 10	FH II 12	FH II 15	FH II 18	FH II 24
Shear load in cracked and uncracked concrete	V	[kN]	10,3	16,0	24,6	37,7	68,0
Corresponding displacements	$\delta_{V0}$	[mm]	3,5	3,5	3,7	5,7	9,0
	$\delta_{V\infty}$	[mm]	5,3	5,3	5,6	8,6	13,5

<sup>1)</sup> Tolerance of clearance hole not included in the displacements

**Table C13:** Displacements due to shear loads for FH II-I and FH II-I A4 <sup>1)</sup>

Anchor type FH II-I and FH II-I A4			FH II 12/M6 I	FH II 12/M8 I	FH II 15/M10 I	FH II 15/M12 I
Shear load in cracked and uncracked concrete	V	[kN]	4,6	8,3	13,3	13,7
Corresponding displacements	$\delta_{V0}$	[mm]	2,6	2,6	2,2	2,2
	$\delta_{V\infty}$	[mm]	3,9	3,9	3,3	3,3

<sup>1)</sup> Tolerance of clearance hole not included in the displacements

fischer High-Performance Anchor FH II, FH II-I

**Performances**  
Displacements under shear loads

**Annex C 8**