

Approval body for construction products
and types of construction

Bautechnisches Prüfamt

An institution established by the Federal and
Laender Governments



European Technical Assessment

ETA-10/0358
of 17 October 2016

English translation prepared by DIBt - Original version in German language

General Part

Technical Assessment Body issuing the
European Technical Assessment:

Deutsches Institut für Bautechnik

Trade name of the construction product

Carl Stahl Wire Ropes I-SYS

Product family
to which the construction product belongs

Prefabricated stainless steel wire ropes with end
connectors

Manufacturer

Carl Stahl ARC GmbH
Siemensstraße 2
73079 Süssen
DEUTSCHLAND

Manufacturing plant

Carl Stahl ARC GmbH
Siemensstraße 2
73079 Süssen
DEUTSCHLAND

This European Technical Assessment
contains

13 pages including 9 annexes which form an integral part
of this assessment

This European Technical Assessment is
issued in accordance with Regulation (EU)
No 305/2011, on the basis of

European Assessment Document (EAD)
200001-00-0602

This version replaces

ETA-10/0358 issued on 8 September 2016

The European Technical Assessment is issued by the Technical Assessment Body in its official language. Translations of this European Technical Assessment in other languages shall fully correspond to the original issued document and shall be identified as such.

Communication of this European Technical Assessment, including transmission by electronic means, shall be in full. However, partial reproduction may only be made with the written consent of the issuing Technical Assessment Body. Any partial reproduction shall be identified as such.

This European Technical Assessment may be withdrawn by the issuing Technical Assessment Body, in particular pursuant to information by the Commission in accordance with Article 25(3) of Regulation (EU) No 305/2011.

Specific part

1 Technical description of the product

The construction products are prefabricated high-strength stainless steel wire ropes with appropriate end connectors and the trade name "Carl Stahl Wire Ropes I SYS".

Drawings of the wire ropes with end connectors as well as their essential dimensions are given in the Annexes to this European technical assessment.

2 Specification of the intended use in accordance with the applicable European Assessment Document

The intended use comprises all typical structural applications of stainless steel wire ropes taking into account the national provisions of the Member State applicable for the location where the product is incorporated in the works.

The wire ropes with end connectors are intended for the use in structures with static or quasi-static loads according to EN 1990:2002, where no verification of fatigue relating to EN 1993-1-9:2005 is necessary.

The installed wire ropes with end connectors shall be accessible (in order) to facilitate replacement of individual components at any time.

The performances given in Section 3 are only valid if the prefabricated high-strength stainless steel wire ropes with appropriate end connectors are used in compliance with the specifications and conditions given in Annex A and Annexes B1 to B7.

The verifications and assessment methods on which this European Technical Assessment is based lead to the assumption of a working life of the prefabricated high-strength stainless steel wire ropes with appropriate end connectors of at least 25 years. The indications given on the working life cannot be interpreted as a guarantee given by the producer, but are to be regarded only as a means for choosing the right products in relation to the expected economically reasonable working life of the works.

3 Performance of the product and references to the methods used for its assessment

3.1 Mechanical resistance and stability (BWR 1)

3.1.1 Characteristics of the product

3.1.1.1 Wire ropes

The wire ropes mentioned in section 1 shall correspond to EN 10264-4:2002 as well as to the series of the standards EN 12385. In addition the indications in section 3.1.1.2 as well as Annexes B2 to B7 shall be taken into account.

3.1.1.2 End connectors (Fork end connectors and threaded end connectors, turnbuckles)

For the product characteristics of the end connectors the indications in Annex B3 apply.

The dimensions shall correspond to the indications in Annexes B4 to B7. The threads shown in Annexes B4, B6 and B7 are metric ISO threads M 10 to M 36. The dimensions and tolerances not indicated in Annexes B4 to B7 shall correspond to the indications laid down in the technical documentation¹ to this European technical assessment.

The end connectors shown in Annexes B4 to B7 may be used for open spiral strands and strand ropes according to the indications given in Annexes B2 to B7.

¹ The technical documentation to this European technical approval is deposited with Deutsches Institut für Bautechnik and, as far as relevant for the tasks of the approved bodies involved in the attestation of conformity procedure is handed over to the approved bodies.

English translation prepared by DIBt

3.1.1.3 Pins for fork end connectors

The indications given in Annexes B3, B5 and B7 apply.

3.1.1.4 Durability

The rules given in EN 1993-1-11:2006, section 4 and EN 1090-2:2008 shall be taken into account.

3.1.2 Performance

Essential characteristic	Performance
Breaking strength	See Annexes B2 and B3
Modulus of deformation / elasticity	

3.2 Safety in case of fire (BWR 2)

Essential characteristic	Performance
Reaction to fire	Class A1 according to EN 13501-1:2007+A1:2009

The components of the tension rod system satisfy the requirements for performance class A1 of the characteristic reaction to fire, in accordance with the provisions of EC decision 96/603/EC (as amended).

4 Assessment and verification of constancy of performance (AVCP) system applied, with reference to its legal base

In accordance with EAD No. 200001-00-0602 the applicable European legal act is: Decision 1998/214/EC.

The system to be applied is: 2+

5 Technical details necessary for the implementation of the AVCP system, as provided for in the applicable EAD

Technical details necessary for the implementation of the AVCP system are laid down in the control plan deposited with Deutsches Institut für Bautechnik.

Issued in Berlin on 8 September 2016 by Deutsches Institut für Bautechnik

Uwe Bender
Head of Department

beglaubigt:
Stöhr

Annex A

A.1 Assumptions concerning design

The design is carried out according to EN 1993-1-11:2006.

The design values of resistance given below are used for design.

The loading is static or quasi-static according to EN 1990:2002 without need of verification of fatigue relating to EN 1993-1-9:2005.

The dimensions, tolerances, material properties and thread engagements stated in this European technical assessment are observed.

The design is carried out by a designer of the structure experienced in the field of steel structures.

Design tension resistance of the wire ropes with end connectors

The design value of the tension resistance F_{Rd} of the wire ropes including the end connectors shall be determined as follows:

$$F_{Rd} = F_{uk} / (1.5 \cdot \gamma_R)$$

Where:

$$F_{uk} = F_{min} \cdot k_e$$

characteristic value of the breaking strength of the wire ropes

F_{min} : minimum breaking force according to Annex B2

k_e : loss factor according to Annex B2

$$\gamma_R = 1.0$$

The value given for the partial safety factor γ_R is a recommended value. It should be used in cases where no values are given in national regulations of the Member State where the wire ropes with end connectors are used or in the respective National Annex to Eurocode 3.

Resistance of pins

The resistance of the pins of the fork end connectors is already covered by the tension resistance F_{Rd} of the wire ropes with end connectors (as before) if the thickness of the gusset plate is according to the indications in Annexes B5 and B7.

A.2 Assumptions concerning Installation

The installation is carried out such that the wire ropes with end connectors are accessible for repair or maintenance at any time.

The installation is only carried out according to the manufacturer's instructions. The manufacturer hands over the assembly instructions to the assembler. From the assembly instructions it is followed that, prior to installation, all components of the wire ropes with end connectors shall be checked for their perfect condition and that damaged components shall not be used.

By using end connectors consisting of threaded end connector, turnbuckle and fork end connector with thread (see Annex B1) the threaded end connectors as well as the fork end connectors with thread are screwed in to the turnbuckles with a minimum thread engagement corresponding to the dimension "c" according to Annex B6.

The responsible assembler attests by notation that all connections with threads were checked concerning the keeping of the minimum thread engagements.

The conformity of the gusset plates and the installed wire ropes with end connectors with the provisions of the European technical approval is attested by the executing assembler.

A.3 Indications to the manufacturer

The manufacturer shall ensure that the information on the specific conditions is given to those who are concerned. This information may be given by reproduction of the European technical assessment.

In addition all essential installation data shall be shown clearly on the package or on an enclosed instruction sheet, preferably using illustration(s).

The wire ropes with end connectors shall be packaged and delivered as a complete unit only.

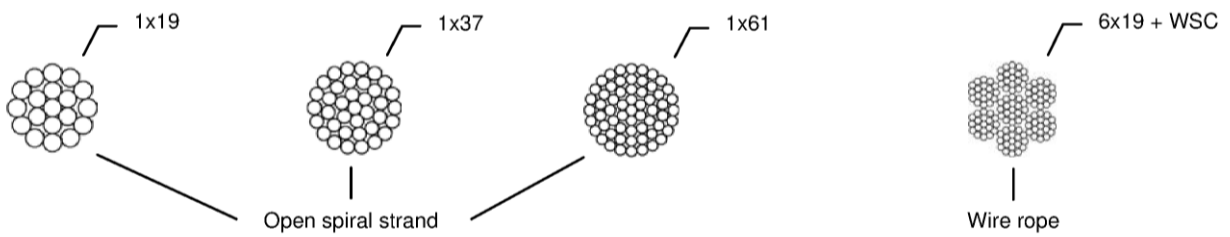
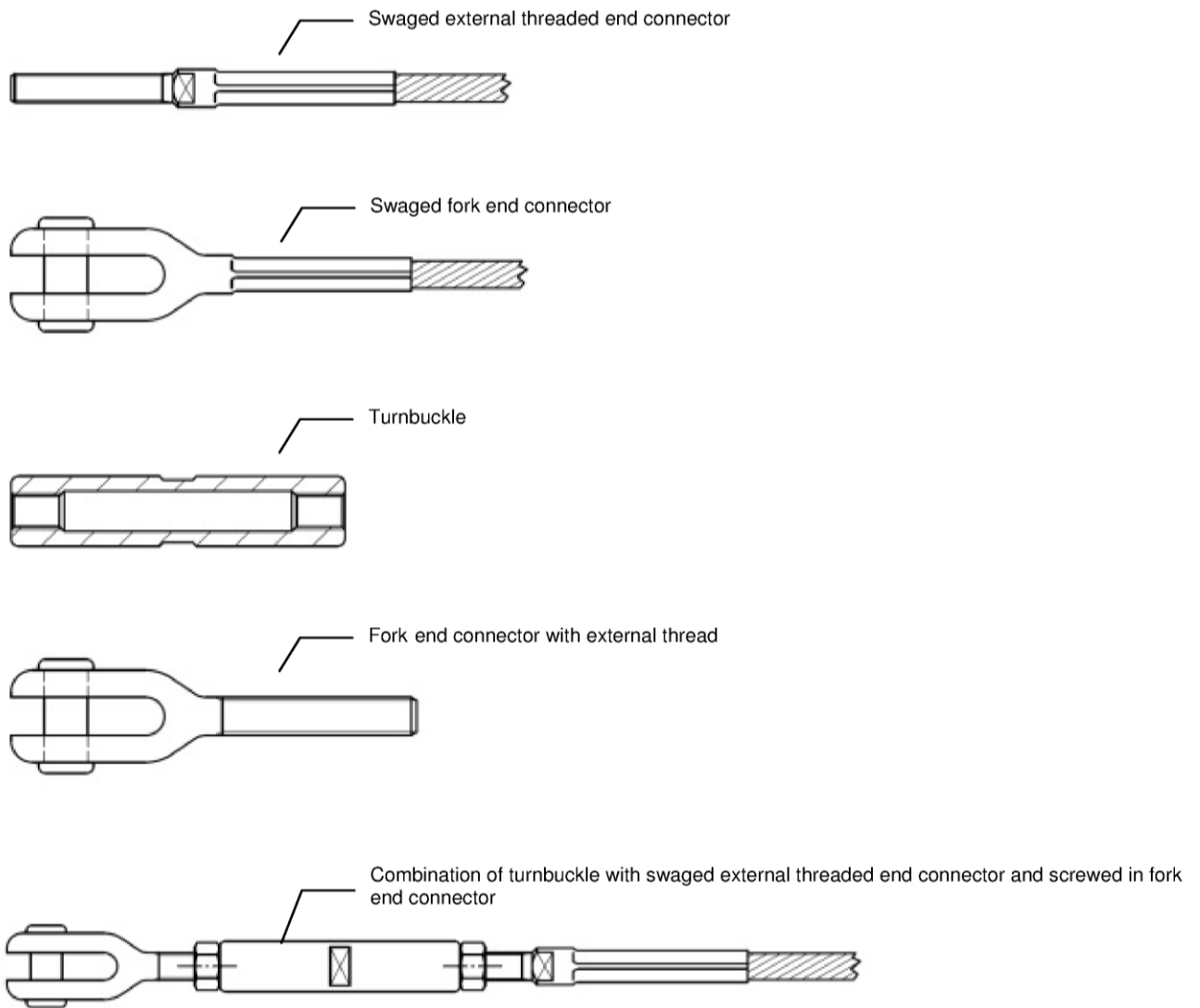

Carl Stahl Wire Ropes I-SYS

System, components

Annex B1

Table 1: Modulus of elasticity E_Q according to EN 1993-1-11:2006
Minimum breaking force F_{min}
Loss factor k_e

Structure		Seil Ø [mm]	E_Q [kN/mm ²]	F_{min} [kN]	k_e [-]
Open spiral strand	1 x 19	6	130	29.7	0.9
	1 x 19	8	130	52.8	0.9
	1 x 19	10	130	82.5	0.83
	1 x 19	12	130	118.7	0.78
	1 x 19	14	130	161.6	0.82
	1 x 37	16	130	192.9	0.88
	1 x 37	18	130	244.0	0.88
	1 x 61	22	130	364.6	0.78
	1 x 61	26	130	509.3	0.78
Strand rope	6 x 19+WSC	6	90	20.5	0.9
	6 x 19+WSC	8	90	36.4	0.9
	6 x 19+WSC	10	90	56.8	0.85
	6 x 19+WSC	12	90	81.8	0.9
	6 x 19+WSC	14	90	111.4	0.9

Carl Stahl Wire Ropes I-SYS

Characteristics of product

Annex B2

Table 2: Mechanical properties for components after cold work hardening (min. values),
Coefficient of thermal expansion

Components	Material- no.:	Mechanical properties ¹⁾		Coefficient of thermal expansion
		R _{p0,2} [N/mm ²]	R _m [N/mm ²]	α _T [K ⁻¹]
Wire of rope 6x19 - WSC	1.4401	-	1570	16x10 ⁻⁶
Wire of rope 1x19	1.4401	-	1570	16x10 ⁻⁶
Wire of rope 1x37	1.4401	-	1470	16x10 ⁻⁶
Wire of rope 1x61	1.4401	-	1470	16x10 ⁻⁶
Swaged external threaded end connector	1.4401/1.4404	210	560	16x10 ⁻⁶
Swaged fork end connector (incl. pin)	1.4401/1.4404	210	560	16x10 ⁻⁶
Fork end connector with external thread (incl. pin)	1.4401/1.4404	210	560	16x10 ⁻⁶
Turnbuckle	1.4401/1.4404	210	560	16x10 ⁻⁶

¹⁾ See also EN 10264-4:2002

Carl Stahl Wire Ropes I-SYS

Characteristics of product

Annex B3

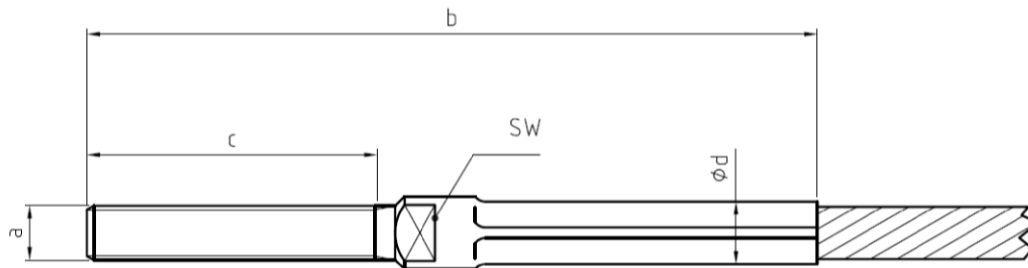

Swaged external threaded end connector					
Rope Ø [mm]	Thread size a ¹⁾	b ²⁾ [mm]	c ³⁾ [mm]	Ød [mm]	SW [mm]
6	M10	117	45	11.11	10
8	M12	156	60	14.03	12
10	M14	193	76	15.75	14
12	M16	232	90	19.03	17
14	M20	259	110	22.24	20
16	M24	313	130	25.25	24
18	M27	357	140	30.46	27
22	M30	430	170	36.40	30
26	M36	475	170	41.18	36

1) Also possible in left or right hand side

2) Depending on c

3) Thread length variable, but max. 500mm and min. see Annex B6

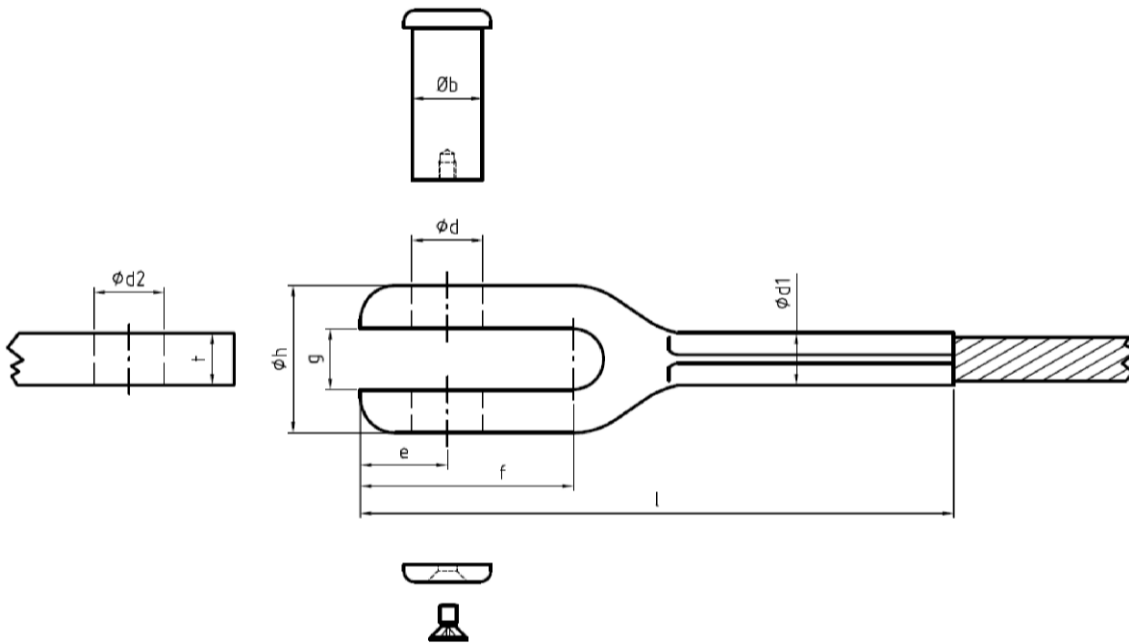

Swaged fork end connector incl. pin									Gusset plate	
Rope Ø [mm]	l [mm]	Øh [mm]	g [mm]	e [mm]	f [mm]	Ød [mm]	Ød1 [mm]	Øb [mm]	Ød2 [mm]	t [mm]
6	116	22	10	14	32	10	11.07	9.9	10	8
8	151	28	12	16	40	12	14.03	11.9	12	10
10	185	34	14	20	49	16	15.70	15.9	16	12
12	220	41	17	25	60	20	18.88	19.9	20	15
14	238	48	20	28	69	23	22.24	22.9	23	18
16	286	54.5	22	33	81	26	25.20	25.9	26	20
18	335	69.5	28	38	91	29	30.46	28.9	29	25
22	379	72	30	40	101	33	36.48	32.9	33	25
26	445	83	33	45	116	36	41.18	35.9	36	30

Carl Stahl Wire Ropes I-SYS

Swaged fork end connector, pin, gusset plate

Annex B5

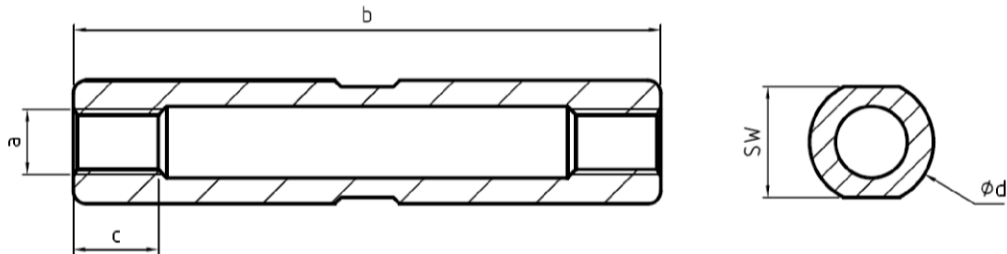

Turnbuckle				
Thread size a	b [mm]	c ¹⁾ [mm]	Ød [mm]	SW [mm]
M10	90	13	19	17
M12	104	15	20	18
M14	136	17	25	22
M16	158	20	28	24
M20	196	24	32	28
M24	230	29	40	36
M27	244	33	48	41
M30	302	36	54	46
M36	302	44	60	55

¹⁾ Minimum thread engagement

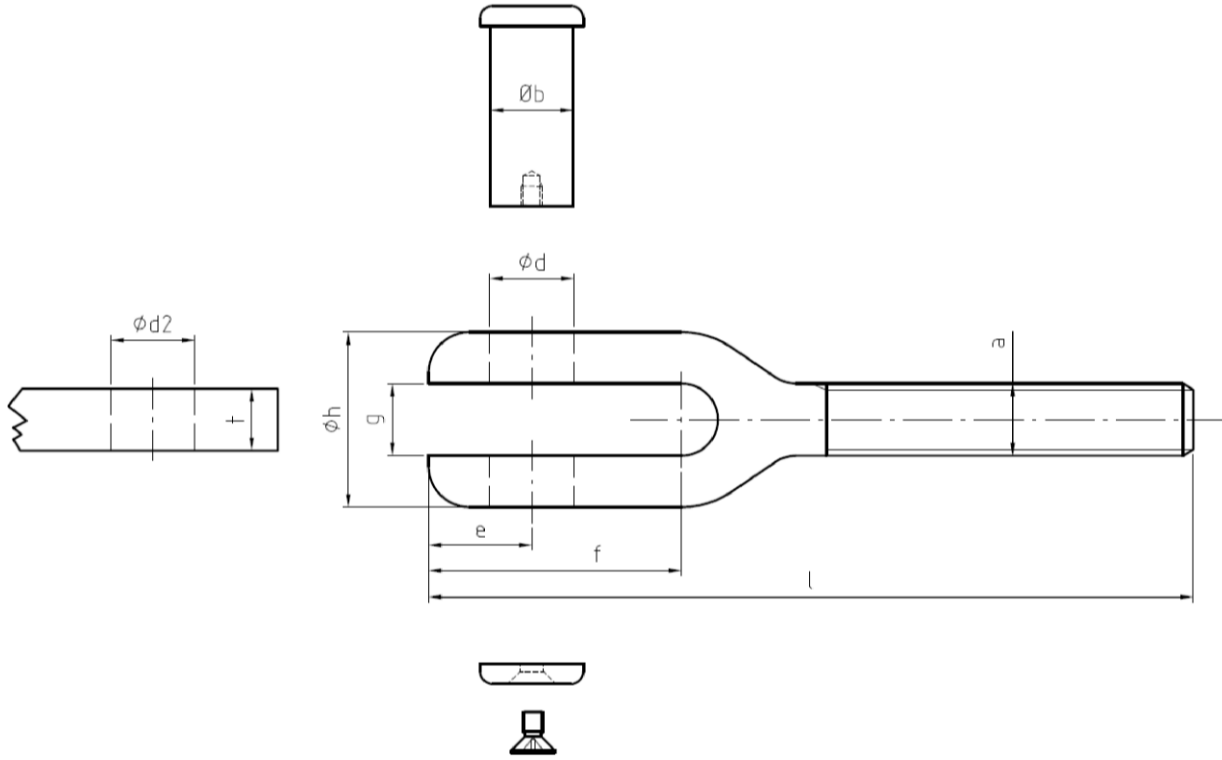

Fork end connector with external thread incl. pin									Gusset plate	
Rope Ø [mm]	Thread size a ¹⁾	l ²⁾ [mm]	Øh [mm]	g [mm]	e [mm]	f [mm]	Ød [mm]	Øb [mm]	Ød2 [mm]	t [mm]
6	M10	93	22	10	14	32	10	9.9	10	8
8	M12	121	28	12	16	40	12	11.9	12	10
10	M14	148	34	14	20	49	16	15.9	16	12
12	M16	180	41	17	25	60	20	19.9	20	15
14	M20	214	48	20	28	69	23	22.9	23	18
16	M24	260	54.5	22	33	81	26	25.9	26	20
18	M27	284	69.5	28	38	91	29	28.9	29	25
22	M30	322	72	30	40	101	33	32.9	33	25
26	M36	346	83	33	45	116	36	35.9	36	30

¹⁾ Also possible in left or right hand side

²⁾ Depending on thread length, but max. l +500mm and min. see Annex B6

Carl Stahl Wire Ropes I-SYS

Fork end connector with external thread, pin, gusset plate

Annex B7