

Approval body for construction products
and types of construction

Bautechnisches Prüfamt

An institution established by the Federal and
Laender Governments



European Technical Assessment

ETA-14/0426
of 21 December 2016

English translation prepared by DIBt - Original version in German language

General Part

Technical Assessment Body issuing the
European Technical Assessment:

Deutsches Institut für Bautechnik

Trade name of the construction product

Powder-actuated fastener X-CR52 P8 S15 and X-CR48
P8 S15

Product family
to which the construction product belongs

Power-actuated fastener for multiple use in concrete for
non-structural applications

Manufacturer

Hilti AG
Feldkircherstraße 100
9494 Schaan
FÜRSTENTUM LIECHTENSTEIN

Manufacturing plant

Hilti AG
Werk 1

This European Technical Assessment
contains

13 pages including 3 annexes which form an integral part
of this assessment

This European Technical Assessment is
issued in accordance with Regulation (EU)
No 305/2011, on the basis of

European Assessment Document (EAD)
330083-00-0601

This version replaces

ETA-14/0426 issued on 15 December 2014

The European Technical Assessment is issued by the Technical Assessment Body in its official language. Translations of this European Technical Assessment in other languages shall fully correspond to the original issued document and shall be identified as such.

Communication of this European Technical Assessment, including transmission by electronic means, shall be in full. However, partial reproduction may only be made with the written consent of the issuing Technical Assessment Body. Any partial reproduction shall be identified as such.

This European Technical Assessment may be withdrawn by the issuing Technical Assessment Body, in particular pursuant to information by the Commission in accordance with Article 25(3) of Regulation (EU) No 305/2011.

English translation prepared by DIBt

Specific part

1 Technical description of the product

The powder-actuated fasteners Hilti X-CR48 P8 S15 and X-CR52 P8 S15 made of stainless steel are driven in a pre-drilled hole in the concrete by using a powder-actuated fastening tool and a cartridge as propellant charge. They are anchored in the concrete by sintering and mechanical interlock.

The product description is given in Annex A.

The characteristic material values, dimensions and tolerances of the fastener not given in Annex A correspond to the respective values laid down in the technical documentation of this ETA. The technical documentation of this ETA is deposited at the Deutsches Institut für Bautechnik.

2 Specification of the intended use in accordance with the applicable European assessment Document

The performances given in Section 3 are only valid if the fastener is used in compliance with the specifications and conditions given in Annex B.

The verifications and assessment methods on which this European Technical Assessment is based lead to the assumption of a working life of the fastener of at least 50 years. The indications given on the working life cannot be interpreted as a guarantee given by the producer, but are to be regarded only as a means for choosing the right products in relation to the expected economically reasonable working life of the works.

3 Performance of the product and references to the methods used for its assessment

3.1 Mechanical resistance and stability (BWR 1)

Essential characteristic	Performance
Characteristic and design values of resistance and displacements in non-cracked and cracked concrete	See Annex C1 and C2
Durability	Durability is ensured if the specifications of intended use according to Annex B are taken into account.

3.2 Safety in case of fire (BWR 2)

Essential characteristic	Performance
Reaction to fire	Anchorage satisfy requirements for Class A1
Resistance to fire	See Annex C3

4 Assessment and verification of constancy of performance (AVCP) system applied, with reference to its legal base

In accordance with EAD No. 330083-00-0601, the applicable European legal act is: 1997/463/EC.

The system to be applied is: 2+

electronic copy of the eta by dibt: eta-14/0426

5 Technical details necessary for the implementation of the AVCP system, as provided for in the applicable European Assessment Document

Technical details necessary for the implementation of the AVCP system are laid down in the control plan deposited at Deutsches Institut für Bautechnik.

Issued in Berlin on 21 December 2016 by Deutsches Institut für Bautechnik

Andreas Kummerow
p. p. Head of Department

beglaubigt:
Wittstock

Powder-actuated fasteners X-CR48 P8 S15 and X-CR52 P8 S15

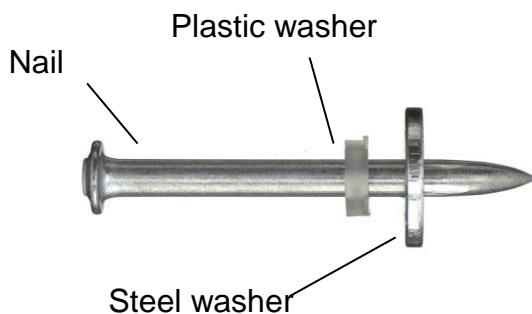

Installed condition

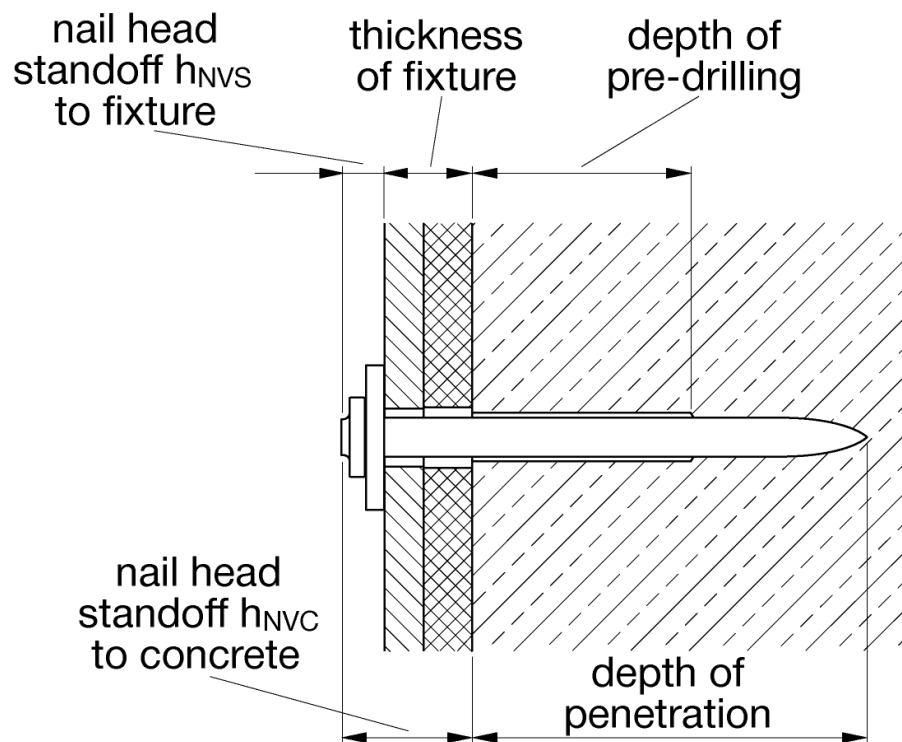

electronic copy of the eta by dibt: eta-14/0426

<p>Powder-actuated fasteners X-CR52 P8 S15 and X-CR48 P8 S15</p>	<p>Annex A1</p>
<p>Product and intended use</p>	

Powder-actuated fasteners: dimensions and identification (stamping of steel washer)

X-CR48 P8 S15 (L = 50 mm)	X-CR52 P8 S15 (L = 54 mm)
<p>or</p>	

Table 1: Dimensions and materials

Powder-actuated fastener		X-CR48 P8 S15	X-CR52 P8 S15
Shank length	[mm]	48	52
Total length	[mm]	50	54
Shank diameter	[mm]	4	4
Head diameter	[mm]	8	8
Material of nail	[-]	Austenitic stainless Cr-Ni-steel (A4), $f_{uk} = 1800 \text{ N/mm}^2$	
Material of steel washer	[-]	Austenitic stainless steel, material No. 1.4435, EN 10088	
Material of plastic washer	[-]	Propylene	

Powder-actuated fasteners X-CR52 P8 S15 and X-CR48 P8 S15

Dimensions, identification and materials

Annex A2

Specification of intended use

Anchorage subject to:

- Static and quasi-static loads.

Base material:

- Reinforced or unreinforced normal weight concrete according to EN 206-1:2000.
- Strength classes C20/25 to C50/60 according to EN 206-1:2000.
- Cracked and non-cracked concrete.

Use conditions (Environmental conditions):

- Structures subject to dry conditions.
- Structures subject to external atmospheric exposure (including industrial and marine environment) and to permanently damp internal condition, if no particular aggressive conditions exist.

Note: Particular aggressive conditions are e.g. permanent, alternating immersion in seawater or the splash zone of seawater, chloride atmosphere of indoor swimming pools or atmosphere with extreme chemical pollution (e.g. in desulphurization plants or road tunnels where de-icing materials are used).

Design:

- Verifiable calculation notes and drawings shall be prepared taking account of the loads to be anchored. The position of the anchor is indicated on the drawings (e.g. position of the fastener relative to reinforcement or to supports etc.).
- The anchorages are designed under the responsibility of an engineer experienced in anchorages and concrete work.
- The anchorages are designed in accordance with ETAG 001, Annex C, Method C, August 2010.
- The fastener is to be used only for multiple use for non-structural applications with following definition:
 - Number of fixing points $n_1 \geq 4$, number of fasteners per fixing point $n_2 \geq 1$ and design value of actions F_{sd} per fixing point $n_3 \leq 3.0$ kN or
 - Number of fixing points $n_1 \geq 3$, number of fasteners per fixing point $n_2 \geq 1$ and design value of actions F_{sd} per fixing point $n_3 \leq 2.0$ kN.
- The design of the fixture is such that in the case of excessive slip or failure of one fastener the load can be transmitted to neighboring fasteners without significantly violating the requirements on the fixture in the serviceability and ultimate limit state.
- The value n_3 can be increased, if it is shown in the design that the requirements for strength and stiffness of the fixture at the serviceability and ultimate limit state is met after failure of one fastener.

Installation:

- Fastener installation carried out by appropriately qualified personnel and under the supervision of the person responsible for technical matters of the site.

Powder-actuated fasteners X-CR52 P8 S15 and X-CR48 P8 S15

Annex B1

Specification of intended use

Table 2: Concrete strength classes and installation parameters

Powder-actuated fastener		X-CR48 P8 S15	X-CR52 P8 S15
Minimum concrete strength class	[-]	C20/25	
Maximum concrete strength class	[-]	C50/60	
Nominal diameter of drill bit	[mm]	5	
Cutting diameter of drill bit	[mm]	5.4	
Depth of pre-drilling	[mm]	23	
Depth of penetration (see Annex A1)	[mm]	40 – 45	
Maximum diameter of clearance hole or slot width in the fixture	[mm]	5.0 ¹⁾	
Total thickness of fixture t_{fix}	[-]	1 – 5 ²⁾	5 – 9 ³⁾
Maximum nail head standoff h_{NVS} according to Annex C2	[mm]	5	
Minimum thickness of concrete member	[mm]	100	

¹⁾ An increase up to 6.5 mm is allowed for single and double fastenings, i.e. for maximum 2 powder-actuated fasteners per fixing point ($n_2 \leq 2$). In that case the displacement in shear direction needs to be increased with 0.75 mm (Annex C1).

²⁾ Maximum 6 mm in case of supplemental washers according to Annex C2

³⁾ Maximum 10 mm in case of supplemental washers according to Annex C2

Predrilling

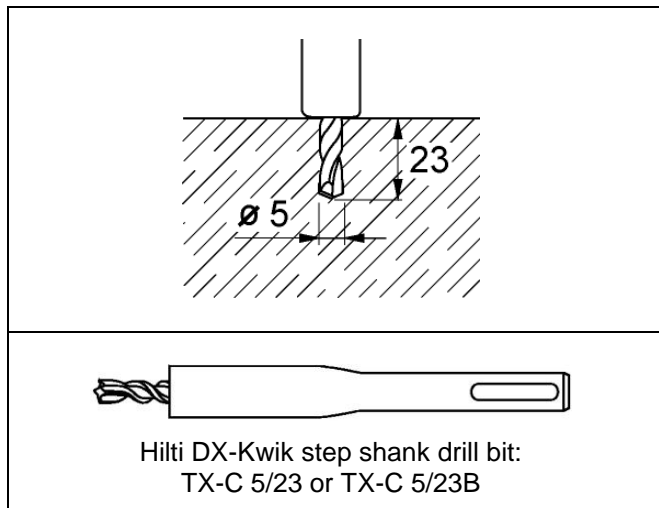

Powder-actuated fasteners X-CR52 P8 S15 and X-CR48 P8 S15

Concrete strength class and installation parameters

Annex B2

Powder-actuated fastening tools DX 5 F8 and DX 460 F8, cartridges 6.8/11M

DX 5 F8



Piston: X-5-460-P8
Fastener guide: X-5-460-F8

DX 460 F8



Piston: X-460-P8 or X-5-460-P8
Fastener guide: X-460-F8 or X-5-460-F8



Wheel on tool allowing regulation of the driving energy:

Setting 1: Minimum energy
Setting 4: Maximum energy



Yellow: Low medium load (level 4)
Red: Medium high load (level 6)
Black: Extra high load (level 7)

Cartridge selection:

C20/25 – C30/37: Yellow / Red

C35/45 – C50/60: Red / Black

The powder-actuated fasteners are to be driven flush. After installation the nail head standoff h_{NVS} has to meet the values given in Annex C2. The driving energy is adjusted at the fastening tool by means of trial installations. If the powder-actuated fastener cannot be driven flush at maximum tool setting (Yellow 4 or Red 4), the next higher cartridge has to be used (Red or Black). The following graph shows the energy overlap of the cartridges Yellow, Red and Black.



Powder-actuated fasteners X-CR52 P8 S15 and X-CR48 P8 S15

Powder-actuated fastening tool and cartridge selection

Annex B3

Instructions for use

- Holes to be drilled perpendicular to the concrete surface by using the corresponding stop drill according to Annex B2. The depth of the drill hole is reached when the drill bit leaves a visible mark in the surface of the concrete. Nominal diameter of drill bit and cutting diameter of drill bit shall be in accordance with the values in Annex B2.
- Positioning of the drill holes without damaging the reinforcement. In case of aborted drill hole a new drill hole shall be at the distance of 2 x depth of the aborted hole at minimum. By vertical downwards drill holes a drill hole cleaning is necessary.
- The powder-actuated fastener is driven in a pre-drilled hole in the concrete by using the powder-actuated fastening tool DX 5 F8 or DX 460 F8 according to Annex B3 and a cartridge 6.8/11M as propellant charge.
- The driving energy shall be determined by fine regulation at test settings according to Annex B3 – in relation to the characteristics of concrete (e.g. concrete strength, concrete aggregates). A control by measuring the fastener stand-off shall be done according to Annex C2.
- The powder-actuated fastener is properly set, if the fixture tightened against the concrete surface and the nail head standoff h_{NVS} is met.
- Powder-actuated fasteners, which don't carry out the required embedment depth or powder-actuated fasteners without pre-drilling must not be loaded.

Example X-CR 52 P8 S15

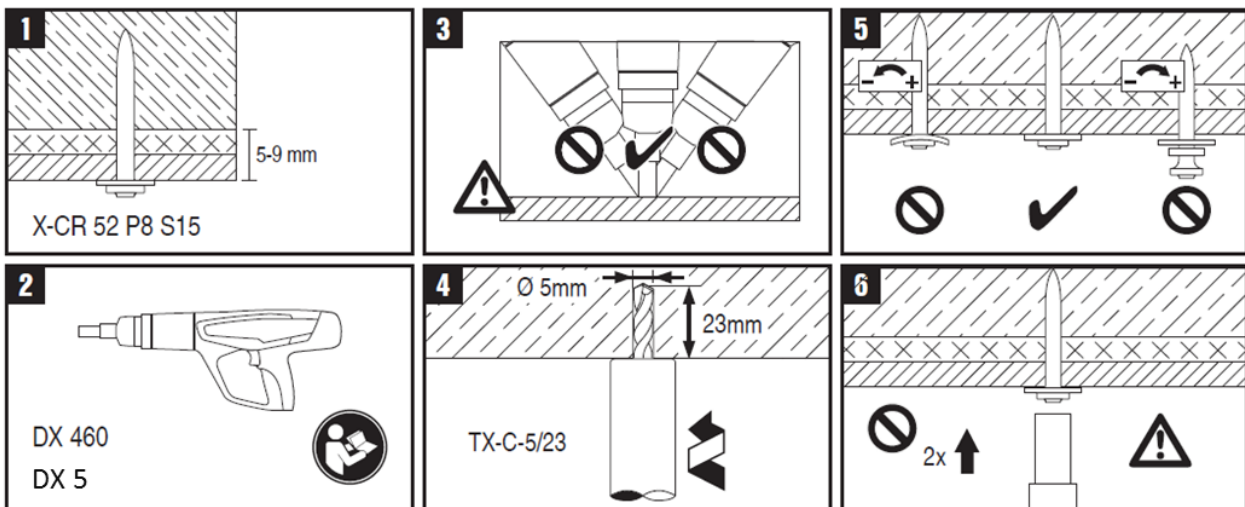

Powder-actuated fasteners X-CR52 P8 S15 and X-CR48 P8 S15

Instructions for use

Annex B4

Table 3: Design values and characteristic values, non-cracked concrete, Design method C

Hilti X-CR DX-Kwik powder-actuated fasteners			X-CR48 P8 S15 and X-CR52 P8 S15
Design value of resistance for all load directions	F_{Rd}	[kN]	3.6
Characteristic bending resistance of fastener shank ¹⁾	$M_{Rk,s}^0$	[Nm]	13.6
Spacing	$s_1 = s_2 = s_{cr} = s_{min}$	[mm]	100
Edge distance	$c_{cr} = c_{min}$	[mm]	150
Reduced edge distance for the specific case of double fastenings ($n_2 = 2$) according to Annex C2	c_1	[mm]	100
Displacement in tension direction at F_{Rd} / γ_F	δ_{N0}	[mm]	< 0.1
	$\delta_{N\infty}$	[mm]	< 0.1
Displacement in shear direction at F_{Rd} / γ_F ²⁾	δ_{V0}	[mm]	1.11
	$\delta_{V\infty}$	[mm]	1.15

¹⁾ For intermediate layers (e.g. plastic for thermal insulation of brackets of ventilated facades) up to a thickness of 5 mm, it is not required to consider the lever arm in case of shear loads.

²⁾ Displacements in shear direction are to be increased with 0.75 mm, if the clearance hole in the fixture is > 5 mm and ≤ 6.5 mm.

Table 4: Design values and characteristic values, cracked concrete, Design method C

Hilti X-CR DX-Kwik powder-actuated fasteners			X-CR48 P8 S15 and X-CR52 P8 S15
Design value of resistance for all load directions	F_{Rd}	[kN]	1.4
Characteristic bending resistance of fastener shank ¹⁾	$M_{Rk,s}^0$	[Nm]	13.6
Spacing	$s_1 = s_2 = s_{cr} = s_{min}$	[mm]	100
Edge distance	$c_{cr} = c_{min}$	[mm]	150
Displacement in tension direction at F_{Rd} / γ_F	δ_{N0}	[mm]	< 0.1
	$\delta_{N\infty}$	[mm]	< 0.1
Displacement in shear direction at F_{Rk} / γ_F ²⁾	δ_{V0}	[mm]	0.63
	$\delta_{V\infty}$	[mm]	0.95

¹⁾ For intermediate layers (e.g. plastic for thermal insulation of brackets of ventilated facades) up to a thickness of 5 mm, it is not required to consider the lever arm in case of shear loads.

²⁾ Displacements in shear direction are to be increased with 0.75 mm, if the clearance hole in the fixture is > 5 mm and ≤ 6.5 mm.

Powder-actuated fasteners X-CR52 P8 S15 and X-CR48 P8 S15

Characteristic and design values of resistance

Annex C1

Reduced edge distance for the specific case of double fastening (i.e. 2 powder-actuated fasteners per fixing point ($n_2 = 2$), e.g. fastening of brackets of ventilated facades)

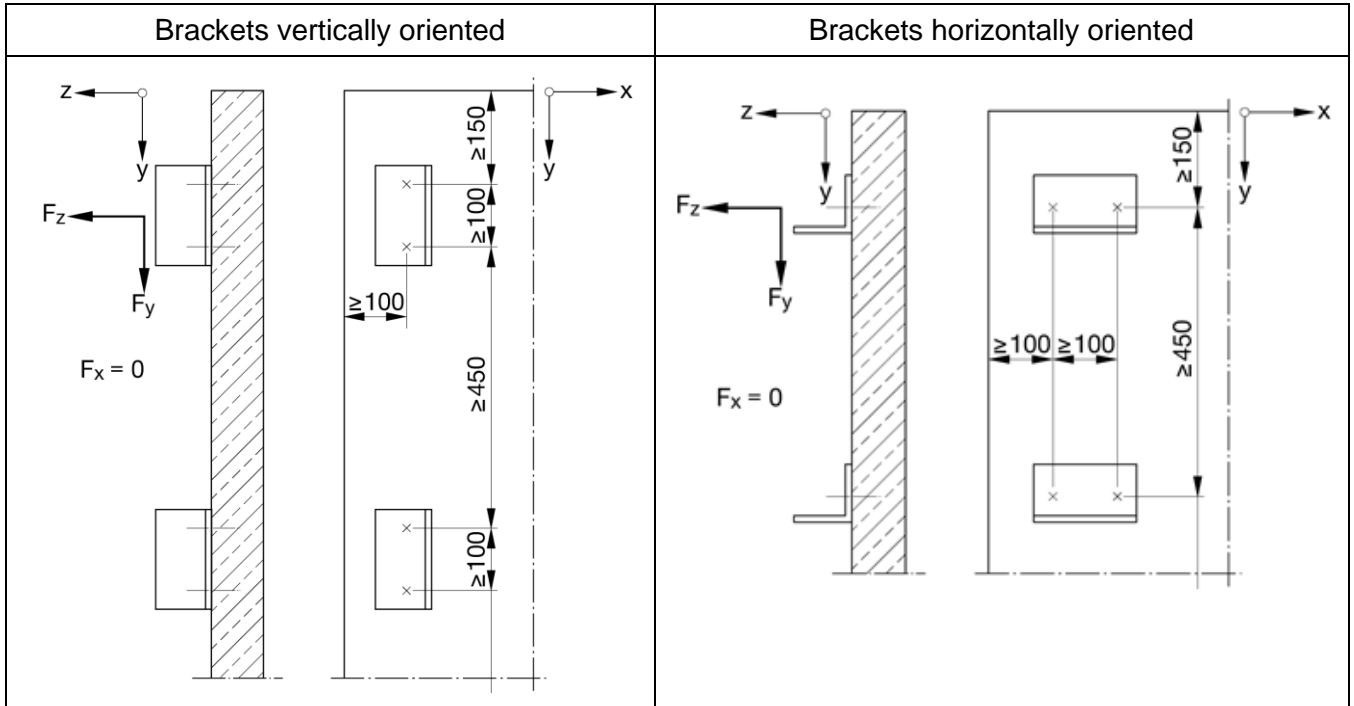

Fastener inspection – fastener stand-off

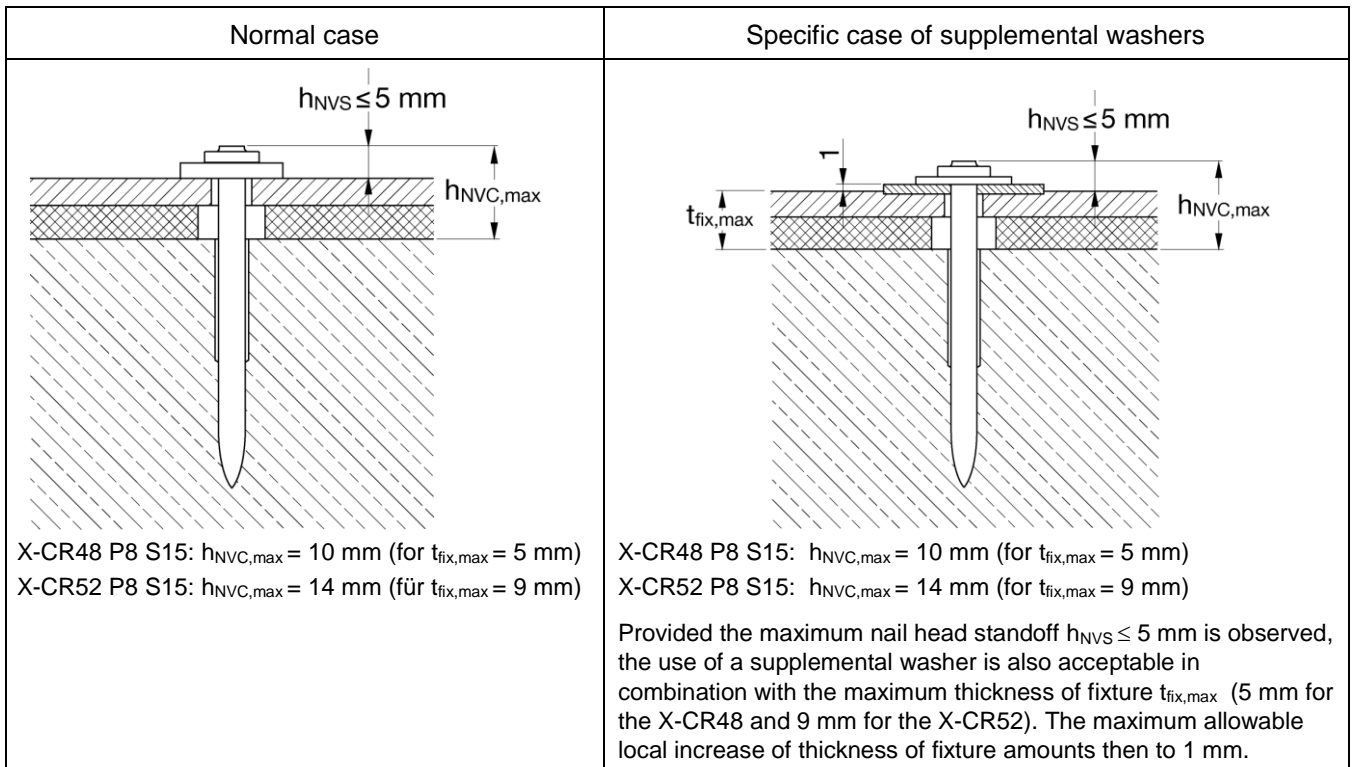

Powder-actuated fasteners X-CR52 P8 S15 and X-CR48 P8 S15

Reduced edge distance in case of special case of double fastening, fastener inspection

Annex C2

**Table 5: Design and characteristic values of resistance in case of fire
for all load directions**

Fire resistance class	Hilti X-CR DX-Kwik powder-actuated fasteners			X-CR48 P8 S15 and X-CR52 P8 S15
R30	Design value of resistance	$F_{Rd,fi(30)}$	[kN]	0.40
	Characteristic bending resistance	$M^0_{Rk,fi(30)}$	[Nm]	0.25
R60	Design value of resistance	$F_{Rd,fi(60)}$	[kN]	0.35
	Characteristic bending resistance	$M^0_{Rk,fi(60)}$	[Nm]	0.20
R90	Design value of resistance	$F_{Rd,fi(90)}$	[kN]	0.25
	Characteristic bending resistance	$M^0_{Rk,fi(90)}$	[Nm]	0.15
R120	Design value of resistance	$F_{Rd,fi(120)}$	[kN]	0.20
	Characteristic bending resistance	$M^0_{Rk,fi(120)}$	[Nm]	0.10
	Partial safety factor ¹⁾	$\gamma_{M,fi}$	[-]	1.00
R30 to R120	Spacing	$s_{cr} = s_{min}$	[mm]	200
	Edge distance with fire attack from one side	$c_{cr} = c_{min}$	[mm]	150
	Edge distance with fire attack from more than one side			300

¹⁾ In the absence of national regulations.

Powder-actuated fasteners X-CR52 P8 S15 and X-CR48 P8 S15

Design and characteristic values of resistance in case of fire

Annex C3