

Approval body for construction products
and types of construction

Bautechnisches Prüfamt

An institution established by the Federal and
Laender Governments



European Technical Assessment

ETA-16/0509
of 17 August 2016

English translation prepared by DIBt - Original version in German language

General Part

Technical Assessment Body issuing the
European Technical Assessment:

Deutsches Institut für Bautechnik

Trade name of the construction product

LTX-8, LMX-8, LGX-8, LTX-10, LMX-10, LGX-10

Product family
to which the construction product belongs

Nailed-in plastic anchor for fixing of external thermal
insulation composite systems with rendering in concrete
and masonry

Manufacturer

Klimas Sp. z o.o.
Kuznica Kiedrzynska
ul. Wincentego Witosa 135/137
42-233 MYKANÓW
POLEN

Manufacturing plant

Klimas Sp. z o.o.

This European Technical Assessment
contains

19 pages including 3 annexes which form an integral part
of this assessment

This European Technical Assessment is
issued in accordance with Regulation (EU)
No 305/2011, on the basis of

Guideline for European technical approval of "Plastic
anchors for fixing of external thermal insulation composite
systems with rendering", ETAG 014, edition February
2011,
used as European Assessment Document (EAD)
according to Article 66 Paragraph 3 of Regulation (EU)
No 305/2011.

The European Technical Assessment is issued by the Technical Assessment Body in its official language. Translations of this European Technical Assessment in other languages shall fully correspond to the original issued document and shall be identified as such.

Communication of this European Technical Assessment, including transmission by electronic means, shall be in full. However, partial reproduction may only be made with the written consent of the issuing Technical Assessment Body. Any partial reproduction shall be identified as such.

This European Technical Assessment may be withdrawn by the issuing Technical Assessment Body, in particular pursuant to information by the Commission in accordance with Article 25(3) of Regulation (EU) No 305/2011.

Specific part

1 Technical description of the product

The nailed-in anchor LTX-8, LMX-8, LGX-8, LTX-10, LMX-10, LGX-10 consists of an anchor sleeve with an enlarged shaft, spreading zone subsequently, an insulation plate made of polyethylene and an accompanying specific nail of galvanised steel for the type LMX and LGX and an accompanying specific nail of polyamide for the type LTX. The serrated expanding part of the anchor sleeve is slotted.

The anchor may in addition be combined with the anchor plates TDX-P-90 / TDX-90 and TDX-P-140 / TDX-140.

An illustration and the description of the product are given in Annex A.

2 Specification of the intended use in accordance with the applicable European Assessment Document

The performances given in Section 3 are only valid if the anchor is used in compliance with the specifications and conditions given in Annex B.

The verification and assessment methods on which this European Technical Assessment is based lead to the assumption of a working life of the anchor of at least 25 years. The indications given on the working life cannot be interpreted as a guarantee given by the producer, but are to be regarded only as a means for choosing the right products in relation to the expected economically reasonable working life of the works.

3 Performance of the product and references to the methods used for its assessment

3.1 Mechanical resistance and stability (BWR 1)

The essential characteristics regarding mechanical resistance and stability are included under the Basic Works Requirement Safety in use.

3.2 Hygiene, health and the environment (BWR 3)

Regarding dangerous substances there may be requirements (e.g. transposed European legislation and national laws, regulations and administrative provisions) applicable to the products falling within the scope of this European Technical Assessment. In order to meet the provisions of Regulation (EU) No 305/2011, these requirements need also to be complied with, when and where they apply.

3.3 Safety and accessibility in use (BWR 4)

Essential characteristic	Performance
Characteristic tension resistance	See Annex C 1, C2
Edge distances and spacing	See Annex B 2
Point thermal transmittance	See Annex C 3
Plate stiffness	See Annex C 3
Displacements	See Annex C 4

3.4 Sustainable use of natural resources (BWR 7)

For the sustainable use of natural resources no performance was determined for this product.

English translation prepared by DIBt

4 Assessment and verification of constancy of performance (AVCP) system applied, with reference to its legal base

In accordance with guideline for European technical approval ETAG 014, February 2011 used as European Assessment Document (EAD) according to Article 66 Paragraph 3 of Regulation (EU) No 305/2011 the applicable European legal act is: 97/463/EC.

The system to be applied is: 2+

5 Technical details necessary for the implementation of the AVCP system, as provided for in the applicable EAD

Technical details necessary for the implementation of the AVCP system are laid down in the control plan deposited with Deutsches Institut für Bautechnik.

Issued in Berlin on 17 August 2016 by Deutsches Institut für Bautechnik

Uwe Bender
Head of Department

beglaubigt:
Ziegler

LTX-8 / LMX-8 / LGX-8 / LTX-10 / LMX-10 / LGX-10

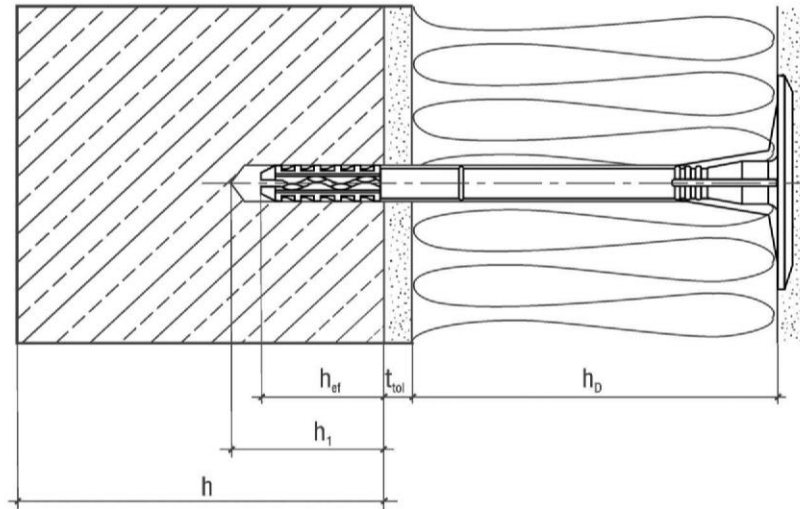

surface mount

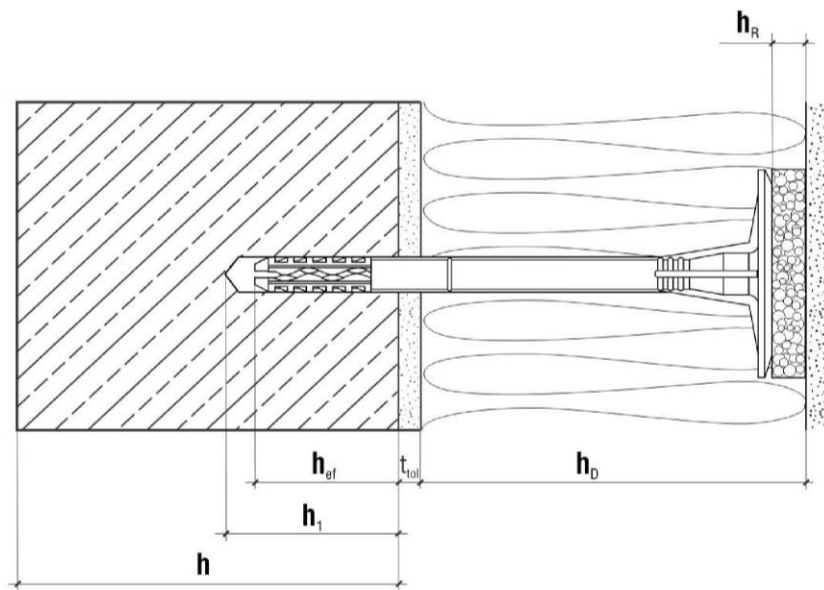

immersed mount

- Legend:
- h_D = thickness of insulation material
 - h_{ef} = effective anchorage depth
 - h = thickness of member (wall)
 - h_1 = depth of drilled hole to deepest point
 - t_{tol} = thickness of equalizing layer or non-load-bearing coating
 - h_R = thickness of insulation cover

LTX-8, LMX-8, LGX-8, LTX-10, LMX-10, LGX-10

Product description

Installed condition – surface mount, immersed mount

Annex A 1

LTX-8

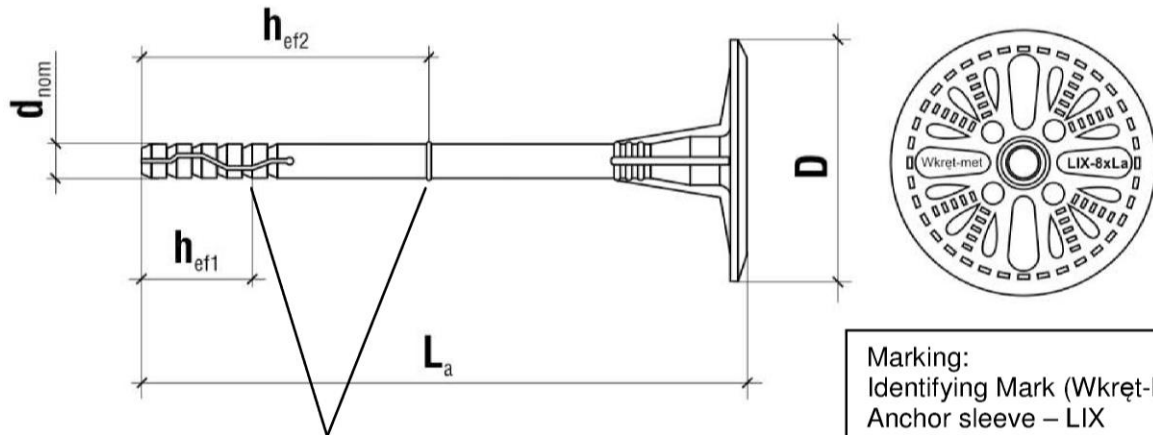

Marking of effective anchorage depth

Marking:
Identifying Mark (Wkret-Met)
Anchor sleeve – LIX
Anchor size – 8xLa

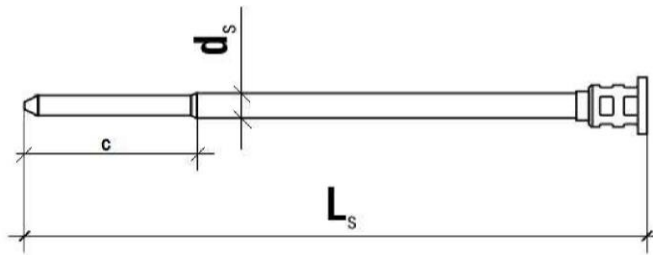

Accompanying specific nail TTX-4,8

Table A1: Dimensions

Anchor Type	Colour	Anchor Sleeve			Specific nail		
		d_{nom} [mm]	h_{ef} [mm]	min L_a max L_a [mm]	d_s [mm]	c [mm]	min L_s max L_s [mm]
LTX-8	natural	8	$h_{ef1} = 25$ $h_{ef2} = 65^*$	95 195	4,8	44	100 200

*) for category E

Determination of maximum thickness of insulation h_D [mm] for LTX-8:

$$h_D = L_a - t_{tol} - h_{ef} \quad (L_a = \text{e.g. } 95; t_{tol} = 10)$$

e.g. $h_D = 95 - 10 - 25 = 60$
 $h_{Dmax} = 60$

LTX-8, LMX-8, LGX-8, LTX-10, LMX-10, LGX-10

Product description

LTX-8 - marking and dimension of the anchor sleeve LIX
Expansion element TTX

Annex A 2

LMX-8

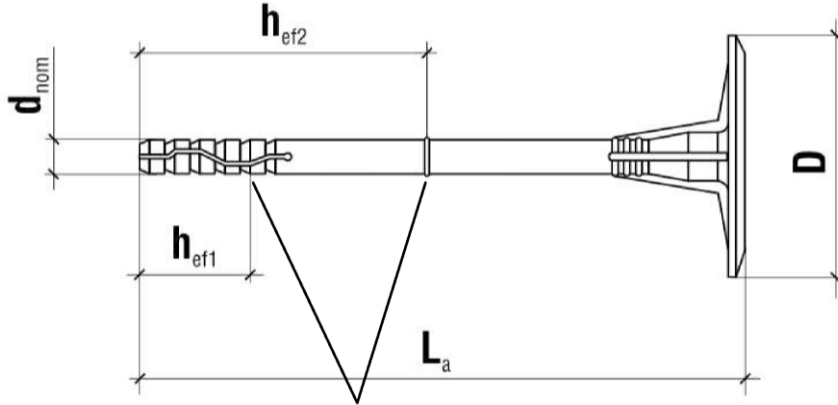

Marking of effective anchorage depth

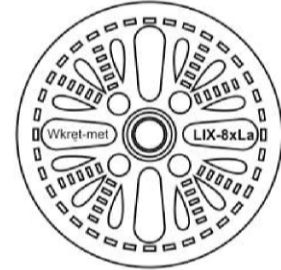

Marking:
Identifying Mark (Wkret-Met)
Anchor sleeve – LIX
Anchor size – 8xLa

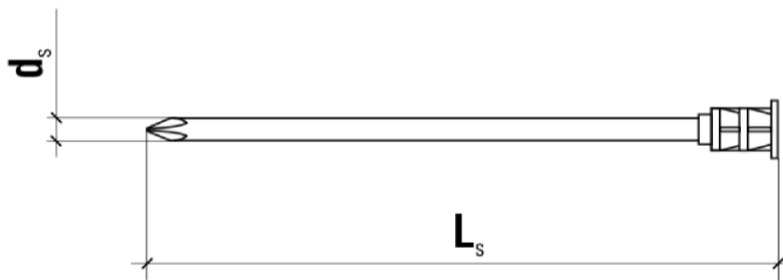

Accompanying specific nail TMX-4,4

Table A2: Dimensions

Anchor Type	Colour	Anchor Sleeve			Specific nail	
		d_{nom} [mm]	h_{ef} [mm]	min L_a max L_a [mm]	d_s [mm]	min L_s max L_s [mm]
LMX-8	natural	8	$h_{ef1} = 25$ $h_{ef2} = 65^*$	95 295	4,4	100 300

*) for category E

Determination of maximum thickness of insulation h_D [mm] for LMX-8:

$$h_D = L_a - t_{tol} - h_{ef} \quad (L_a = \text{e.g. } 95; t_{tol} = 10)$$

e.g. $h_D = 95 - 10 - 25 = 60$

$h_{Dmax} = 60$

LTX-8, LMX-8, LGX-8, LTX-10, LMX-10, LGX-10

Product description

LMX-8 - marking and dimension of the anchor sleeve LIX
Expansion element TMX

Annex A 3

LGX-8

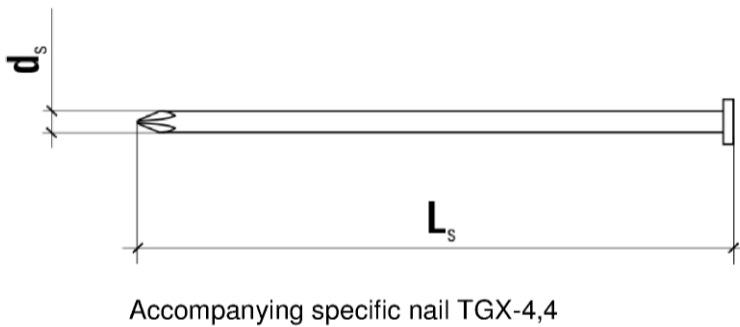
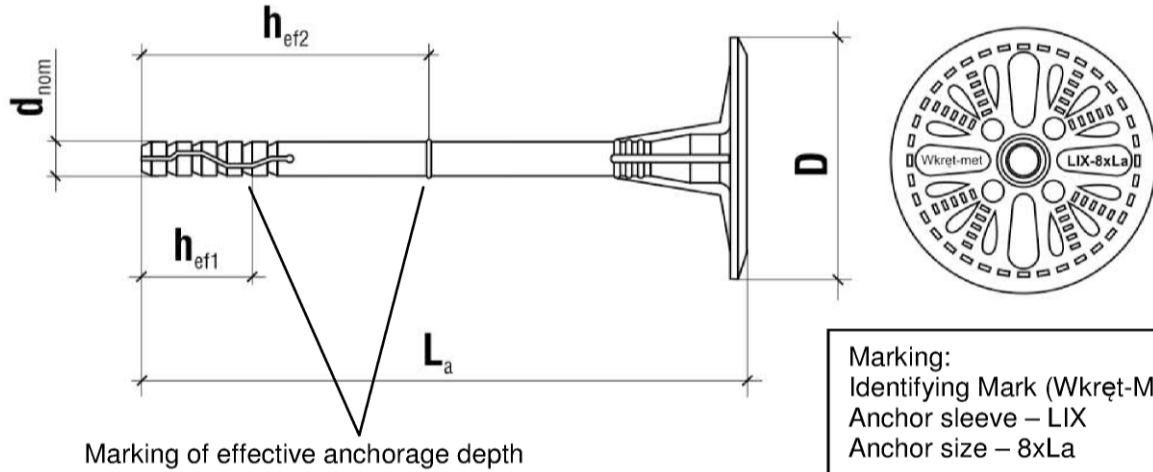

Table A3: Dimensions

Anchor Type	Colour	Anchor Sleeve			Specific nail	
		d_{nom} [mm]	h_{ef} [mm]	min L_a max L_a [mm]	d_s [mm]	min L_s max L_s [mm]
LGX-8	natural	8	$h_{ef1} = 25$ $h_{ef2} = 65^*$	95 295	4,4	100 300

*) for category E

Determination of maximum thickness of insulation h_D [mm] for LGX-8:

$$h_D = L_a - t_{tol} - h_{ef} \quad (L_a = \text{e.g. } 95; t_{tol} = 10)$$

e.g. $h_D = 95 - 10 - 25 = 60$

LTX-8, LMX-8, LGX-8, LTX-10, LMX-10, LGX-10

Product description
LGX-8 - marking and dimension of the anchor sleeve LIX
Expansion element TGX

Annex A 4

LTX-10

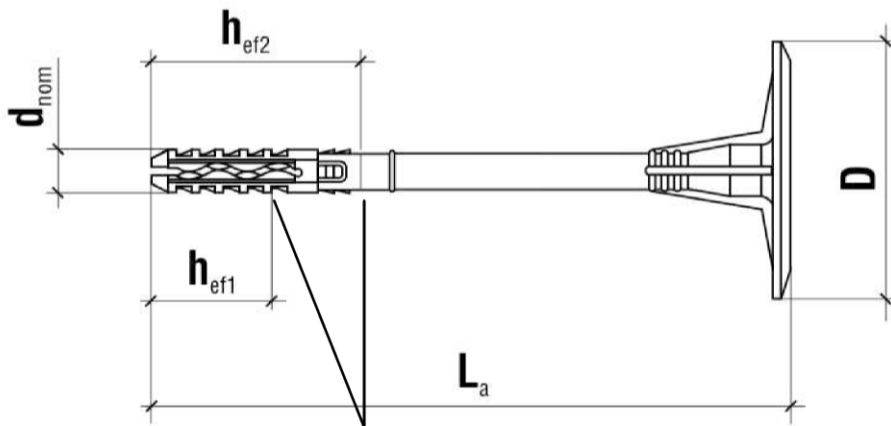

Marking:
Identifying Mark (Wkręć-Met)
Anchor sleeve – LIX
Anchor size – 10xLa

Marking of effective anchorage depth

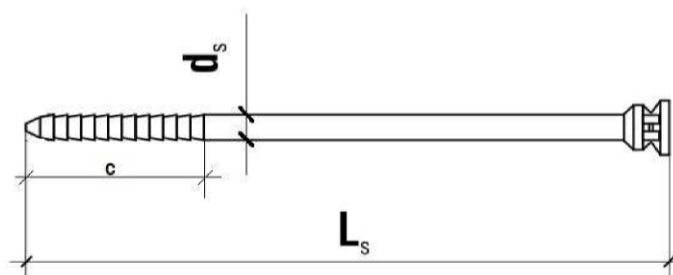

Accompanying specific nail TTX-5,5

Table A4: Dimensions

Anchor Type	Colour	Anchor Sleeve			Specific nail		
		d_{nom} [mm]	h_{ef} [mm]	min L_a max L_a [mm]	d_s [mm]	c [mm]	min L_s max L_s [mm]
LTX-10	natural	10	$h_{ef1} = 30$ $h_{ef2} = 50^*$	70 260	5,5	44	75 265

*) for category E

Determination of maximum thickness of insulation h_D [mm] for LTX-10:

$$h_D = L_a - t_{tol} - h_{ef} \quad (L_a = \text{e.g. } 70; t_{tol} = 10)$$

e.g. $h_D = 70 - 10 - 30$

$$h_{Dmax} = 30$$

LTX-8, LMX-8, LGX-8, LTX-10, LMX-10, LGX-10

Product description
LTX-10 - marking and dimension of the anchor sleeve LIX
Expansion element TTX

Annex A 5

LMX-10

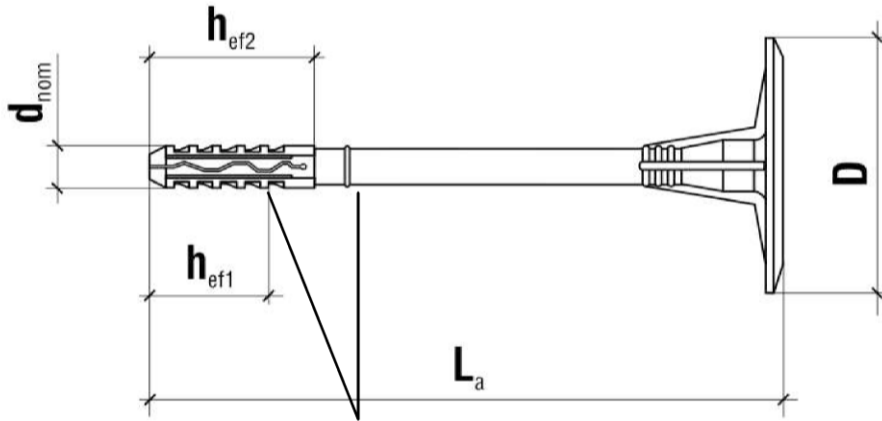

Marking:
Identifying Mark (Wkręć-Met)
Anchor sleeve – LMX
Anchor size – 10xLa

Marking of effective anchorage depth

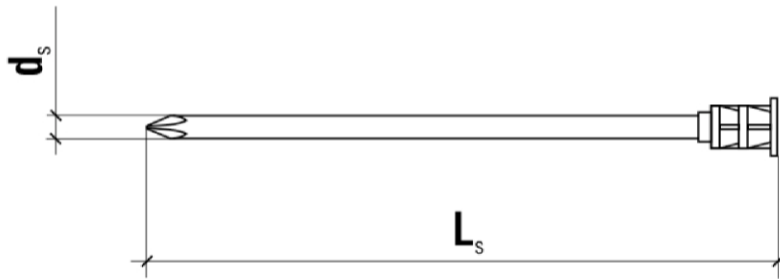

Accompanying specific nail TMX-4,4

Table A5: Dimensions

Anchor Type	Colour	Anchor Sleeve			Specific nail	
		d_{nom} [mm]	h_{ef} [mm]	min L_a max L_a [mm]	d_s [mm]	min L_s max L_s [mm]
LMX-10	natural	10	$h_{ef1} = 30$ $h_{ef2} = 50^*$	70 300	4,4	70 300

*) for category E

Determination of maximum thickness of insulation h_D [mm] for LMX-10:

$$h_D = L_a - t_{tol} - h_{ef} \quad (L_a = \text{e.g. } 70; t_{tol} = 10)$$

e.g. $h_D = 70 - 10 - 30 = 30$
 $h_{Dmax} = 30$

LTX-8, LMX-8, LGX-8, LTX-10, LMX-10, LGX-10

Annex A 6

Product description

LMX-10 - marking and dimension of the anchor sleeve LMX
Expansion element TMX

LGX-10

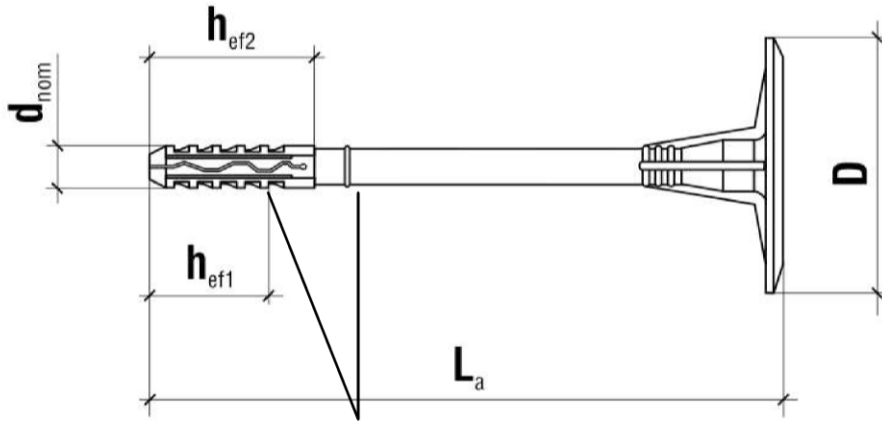

Marking:
Identifying Mark (Wkret-Met)
Anchor sleeve – LMX
Anchor size – 10xLa

Marking of effective anchorage depth

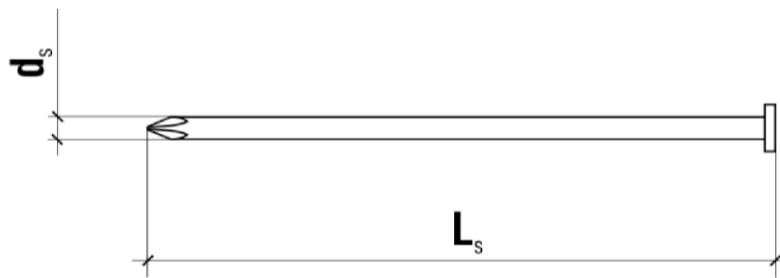

Accompanying specific nail TGX-4,4

Table A6: Dimensions

Anchor Type	Colour	Anchor Sleeve			Specific nail	
		d_{nom} [mm]	h_{ef} [mm]	min L_a max L_a [mm]	d_s [mm]	min L_s max L_s [mm]
LGX-10	natural	10	$h_{ef1} = 30$ $h_{ef2} = 50^*$	70 300	4,4	70 300

*) for category E

Determination of maximum thickness of insulation h_D [mm] for LGX-10:

$$h_D = L_a - t_{tol} - h_{ef} \quad (L_a = \text{e.g. } 70; t_{tol} = 10)$$

e.g. $h_D = 70 - 10 - 30$
 $h_{Dmax} = 30$

LTX-8, LMX-8, LGX-8, LTX-10, LMX-10, LGX-10

Product description
LGX-10 - marking and dimension of the anchor sleeve LMX
Expansion element TGX

Annex A 7

Table A7: Materials

Name	Materials
Anchor sleeve	Polyethylene, colour: natural
Specific nail TTX	Polyamide GF, colour: black or natural
Specific nail TMX, TGX	Steel, electro galvanized $\geq 5 \mu\text{m}$ according to EN ISO 4042:2001, white passivated, $f_{yk} \geq 420 \text{ N/mm}^2$

Table A8: Insulation discs, diameters and material

Plate type	Outer diameter [mm]	Material
TDX-P-90	90	Polyethylene, natural or grey
TDX-90	90	Polyamide +GF, natural or grey
TDX-P-140	140	Polyethylene, natural or grey
TDX-140	140	Polyamide + GF, natural or grey

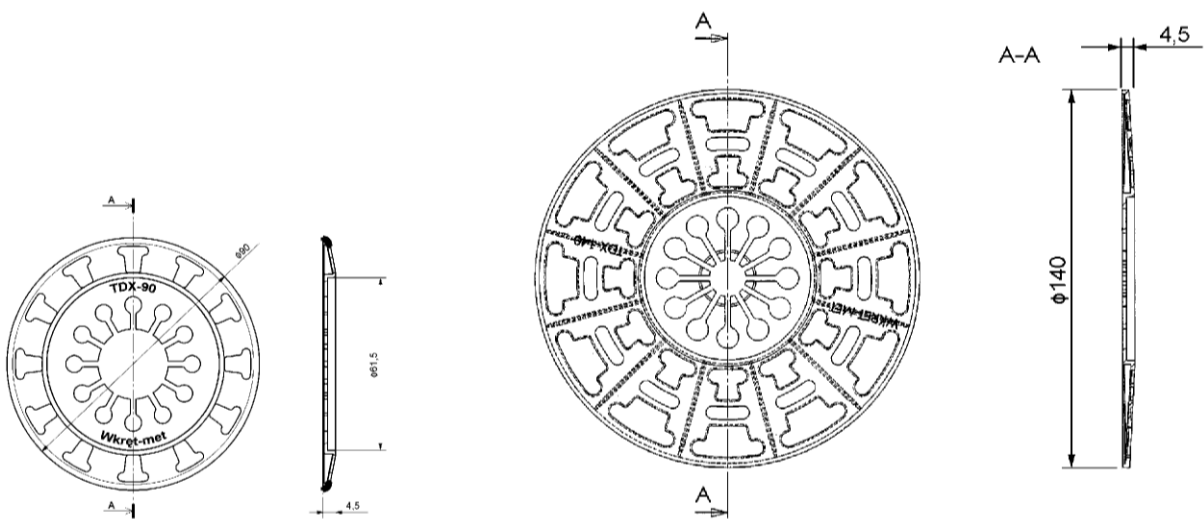

TDX-P-90/TDX-90

TDX-P-140/TDX-140

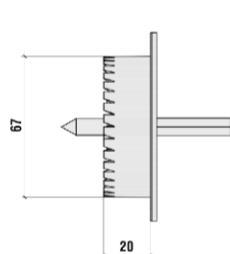

Special drill tool WK-FT for immersed installation

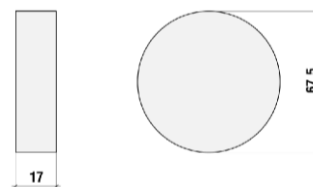

Insulation cover KS and KSG

LTX-8, LMX-8, LGX-8, LTX-10, LMX-10, LGX-10

Product description

Materials,
Slip on plates with LTX-8 / LMX-8 / LGX-8 / LTX-10 / LMX-10 / LGX-10

Annex A 8

Specifications of intended use

Anchorage subject to:

- The anchor may only be used for transmission of wind suction loads and shall not be used for the transmission of dead loads of the thermal insulation composite system.

Base materials:

- Normal weight concrete (use category A) according to Annex C 1
- Solid masonry (use category B), according to Annex C 1
- Hollow or perforated masonry (use category C), according to Annex C 1
- Lightweight aggregate concrete (use category D), according to Annex C 1
- Autoclaved aerated concrete (use category E), according to Annex C 1
- For other base materials of the use categories A, B, C, D or E the characteristic resistance of the anchor may be determined by job site tests according to ETAG 014 Edition February 2011, Annex D.

Temperature Range:

- 0°C to +40°C (max. short term temperature +40°C and max. long term temperature +24°C)

Design:

- The anchorages are designed in accordance with the ETAG 014 Edition February 2011 under the responsibility of an engineer experienced in anchorages and masonry work.
- Verifiable calculation notes and drawings are prepared taking account of the loads to be anchored. The position of the anchor is indicated on the design drawings.
- Fasteners are only to be used for multiple fixings of thermal insulation composite systems.

Installation:

- Hole drilling by the drill modes according to Annex C 1
- Anchor installation carried out by appropriately qualified personnel and under the supervision of the person responsible for technical matters of the site.
- Installation temperature from 0°C to +40°C
- Exposure to UV due to solar radiation of the anchor not protected by rendering ≤ 6 weeks

LTX-8, LMX-8, LGX-8, LTX-10, LMX-10, LGX-10

Intended use
Specifications

Annex B 1

Table B1: Installation parameters for LTX-8 / LMX-8 / LGX-8

		A B C D	E
Drill hole diameter	d_0 [mm] =	8	8
Cutting diameter of drill bit	d_{cut} [mm] ≤	8,45	8,45
Depth of drilled hole to deepest point	h_1 [mm] ≥	35	75
Effective anchorage depth	h_{ef} [mm] ≥	25	65

Table B2: Installation parameters for LTX-10 / LMX-10 / LGX-10

		A B C D	E
Drill hole diameter	d_0 [mm] =	10	10
Cutting diameter of drill bit	d_{cut} [mm] ≤	10,45	10,45
Depth of drilled hole to deepest point	h_1 [mm] ≥	40	60
Effective anchorage depth	h_{ef} [mm] ≥	30	50

Table B3: Anchor distances and dimensions of members

Minimum allowable spacing	$s_{min} \geq$ [mm]	100
Minimum allowable edge distance	$c_{min} \geq$ [mm]	100
Minimum thickness of member	$h \geq$ [mm]	100

Scheme of distance and spacing

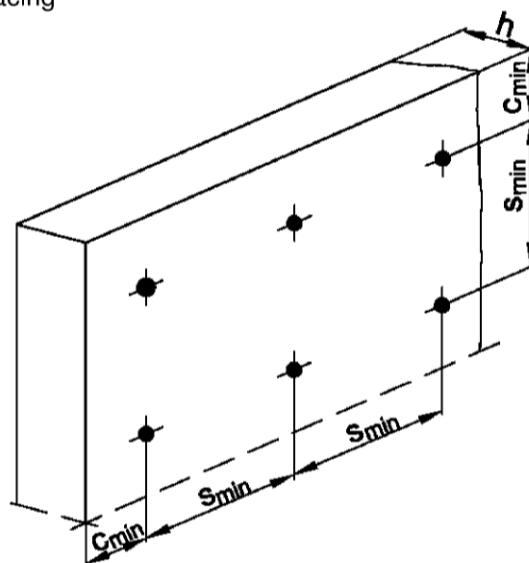

LTX-8, LMX-8, LGX-8, LTX-10, LMX-10, LGX-10

Intended use

Installation parameters,
Edge distances and spacing

Annex B 2

Installation instructions

surface mount

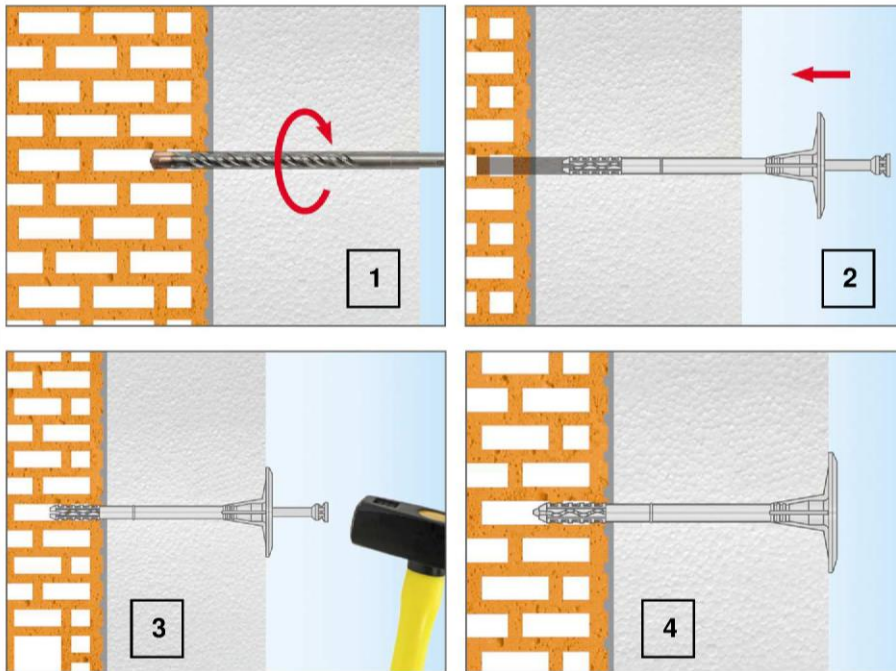

1) Drill the hole perpendicular to the substrate surface. Clean the drill hole.

2) Place the anchor into the drill hole. The bottom side of the plate must be flush with the ETICS.

3) Drive in the specific nail with the hammer.

4) Installed condition.

immersed mount

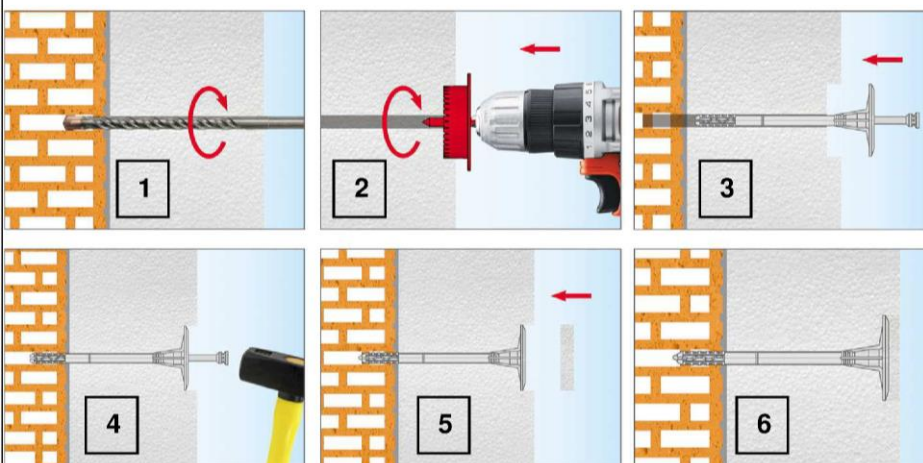

1) Drill the hole perpendicular to the substrate surface. Clean the drill hole.

2) Drill the recess for immersed installation with the special drilling tool WK-FT.

3) Place the anchor into the drill hole. The bottom side of the plate must be flush with the recess in the ETICS.

4) Drive in the specific nail with the hammer.

5) Insert the insulation cover.

6) Installed condition.

LTX-8, LMX-8, LGX-8, LTX-10, LMX-10, LGX-10

Intended use

Installation instructions – surface mount, immersed mount

Annex B 3

Table C1: Characteristic resistance to tension loads N_{Rk} in concrete and masonry for a single anchor in kN						
Anchor type					LTX-8	LMX-8 LGX-8
Base materials	Bulk density class ρ [kg/dm ³]	minimum compressive strength f_b [N/mm ²]	General remarks	Drill method	N_{Rk} [kN]	N_{Rk} [kN]
Concrete C12/15 (EN 206-1:2000)	$\geq 2,25$	≥ 30		hammer	0,5	0,5
Concrete C20/25 - C50/60 (EN 206-1:2000)	$\geq 2,30$	≥ 65		hammer	0,75	0,75
Clay bricks MZ e.g. according to EN 771-1:2011	$\geq 2,0$	≥ 20		hammer	0,75	0,75
Calcium silicate bricks KS e.g. according to EN 771-2:2011	$\geq 2,0$	≥ 20		hammer	0,75	0,75
Calcium silicate hollow block KSL e.g. according to EN 771-2:2011 	$\geq 1,6$	≥ 12	Vertically perforation more than 15 % and less than 50 %	hammer	0,75	0,75
Vertically perforated clay bricks HLZ e.g. according to EN 771-1:2011 	$\geq 1,2$	≥ 12	Vertically perforation more than 15 % and less than 50 %	rotary	0,6	0,6
Vertically perforated clay bricks porotherm 25 e.g. according to EN 771-1:2011 	$\geq 0,8$	≥ 10	Vertically perforation more than 15 %	rotary	0,4	0,4
Autoclaved concrete blocks AAC2 e.g. according to EN 771-4:2011	$\geq 0,35$	≥ 2		rotary	0,75	0,75
Autoclaved concrete blocks AAC7 e.g. according to EN 771-4:2011	$\geq 0,65$	$\geq 3,5$		rotary	0,9	0,9
Lightweight concrete blocks LAC e.g. according to EN 1520:2011-06 / EN 771-3:2011	$\geq 0,88$	≥ 5		rotary	0,6	0,75
LTX-8, LMX-8, LGX-8, LTX-10, LMX-10, LGX-10					Annex C 1	
Performances Characteristic resistance LTX-8, LMX-8, LGX-8						

Table C2: Characteristic resistance to tension loads N_{Rk} in concrete and masonry for a single anchor						
in kN						
Anchor type					LTX-10	LMX-10 LGX-10
Base materials	Bulk density class ρ [kg/dm ³]	minimum compressive strength f_b [N/mm ²]	General remarks	Drill method	N_{Rk} [kN]	N_{Rk} [kN]
Concrete C12/15 (EN 206-1:2000)	$\geq 2,25$	≥ 30		hammer	0,5	0,75
Concrete C20/25 -C50/60 (EN 206-1:2000)	$\geq 2,30$	≥ 65		hammer	0,75	0,9
Clay bricks MZ e.g. according to EN 771-1:2011	$\geq 2,0$	≥ 20		hammer	0,75	0,9
Calcium silicate bricks KS e.g. according to EN 771-2:2011	$\geq 2,0$	≥ 20		hammer	0,6	0,9
Calcium silicate hollow block KSL e.g. according to EN 771-2:2011 	$\geq 1,6$	≥ 12	Vertically perforation more than 15 % and less than 50 %	hammer	0,6	0,9
Vertically perforated clay bricks HLZ e.g. according to EN 771-1:2011 	$\geq 1,2$	≥ 12	Vertically perforation more than 15 % and less than 50 %	rotary	0,6	0,9
Vertically perforated clay bricks porotherm 25 e.g. according to EN 771-1:2011) 	$\geq 0,8$	≥ 10	Vertically perforation more than 15 %	rotary	0,4	0,5
Autoclaved concrete blocks AAC2 e.g. according to EN 771-4:2011	$\geq 0,35$	≥ 2		rotary	0,5	0,75
Autoclaved concrete blocks AAC7 e.g. according to EN 771-4:2011	$\geq 0,65$	$\geq 3,5$		rotary	0,6	0,9
Lightweight concrete blocks LAC e.g. according to EN 1520:2011-06 / EN 771-3:2011	$\geq 0,88$	≥ 5		rotary	0,6	0,9
LTX-8, LMX-8, LGX-8, LTX-10, LMX-10, LGX-10					Annex C 2	
Performances Characteristic resistance LTX-10, LMX-10, LGX-10						

Table C3: Point thermal transmittance according EOTA Technical Report TR 025:2007-06

anchor type	insulation thickness	point thermal transmittance
	h_D [mm]	χ [W/K]
LTX-8 surface mount	60 - 160	0
LTX-8 immersed mount	80 - 160	0
LMX-8 surface mount	60 - 260	0,004
LMX-8 immersed mount	80 - 260	0,002
LGX-8 surface mount	60 - 260	0,006
LGX-8 immersed mount	80 - 260	0,003
LTX-10 surface mount	30 - 220	0,001
LTX-10 immersed mount	50 - 220	0
LMX-10 surface mount	30 - 260	0,004
LMX-10 immersed mount	50 - 260	0,002
LGX-10 surface mount	30 - 260	0,007
LGX-10 immersed mount	50 - 260	0,003

Table C4: Plate stiffness according EOTA Technical Report TR 026:2007-06

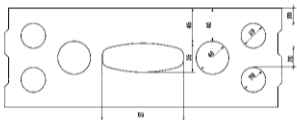
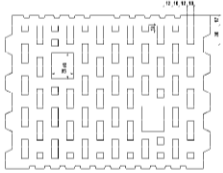
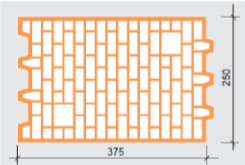
anchor type	diameter of the anchor plate	load resistance of the anchor plate	plate stiffness
	[mm]	[kN]	[kN/mm]
LTX-8/LMX-8/LGX-8	60	1,09	0,5
LTX-10/LMX-10/LGX-10	60	1,02	0,5

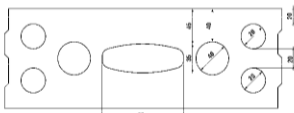
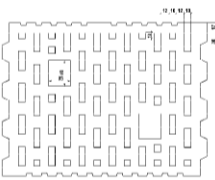
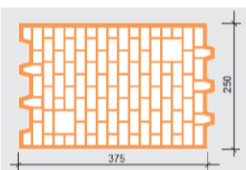
LTX-8, LMX-8, LGX-8, LTX-10, LMX-10, LGX-10

Performances

Point thermal transmittance, plate stiffness

Annex C 3

Table C5: Displacements LTX-8 and LTX-10

Base materials (refer Table C1, C2)	Bulk density class ρ [kg/dm ³]	Minimum Compressive strength f_b [N/mm ²]	Tension load N [kN]		Displacements $\delta(N)$ [mm]	
			LTX-8	LTX-10	LTX-8	LTX-10
Concrete C20/25	≥ 2,25	≥ 30	0,17	0,17	1,5	1,4
Concrete C50/60	≥ 2,30	≥ 65	0,25	0,25	1,5	1,8
Clay bricks MZ	≥ 2,0	≥ 20	0,25	0,25	0,5	0,6
Calcium silicate bricks KS	≥ 2,0	≥ 20	0,25	0,2	0,8	1,1
Calcium silicate hollow block KSL	≥ 1,6	≥ 12	0,25	0,2	1,0	1,5
Vertically perforated clay bricks HLZ	≥ 1,2	≥ 12	0,2	0,2	1,2	1,4
Perforated clay bricks porotherm 25	≥ 0,8	≥ 10	0,13	0,13	0,6	0,5
Autoclaved concrete blocks AAC2	≥ 0,35	≥ 2	0,25	0,17	0,8	1,3
Autoclaved concrete blocks AAC7	≥ 0,65	≥ 3,5	0,3	0,2	1,3	1,8
Lightweight concrete blocks LAC	≥ 0,88	≥ 5	0,2	0,2	0,9	1,5

Table C6: Displacements LMX-8/LGX-8 and LMX-10/LGX-10

Base materials (refer Table C1, C2)	Bulk density class ρ [kg/dm ³]	Minimum Compressive strength f_b [N/mm ²]	Tension load N [kN]		Displacements $\delta(N)$ [mm]	
			LMX-8/ LGX-8	LMX-10/ LGX-10	LMX-8/ LGX-8	LMX-10/ LGX-10
Concrete C20/25	≥ 2,25	≥ 30	0,17	0,25	2,1	1,3
Concrete C50/60	≥ 2,30	≥ 65	0,25	0,3	2,4	1,5
Clay bricks MZ	≥ 2,0	≥ 20	0,25	0,3	2,0	0,8
Calcium silicate bricks KS	≥ 2,0	≥ 20	0,25	0,3	0,7	1,0
Calcium silicate hollow block KSL	≥ 1,6	≥ 12	0,25	0,3	1,0	1,3
Vertically perforated clay bricks HLZ	≥ 1,2	≥ 12	0,2	0,3	1,6	1,7
Perforated clay bricks porotherm 25	≥ 0,8	≥ 10	0,13	0,17	0,9	0,8
Autoclaved concrete blocks AAC2	≥ 0,35	≥ 2	0,25	0,25	2,7	2,4
Autoclaved concrete blocks AAC7	≥ 0,65	≥ 3,5	0,3	0,3	2,0	1,4
Lightweight concrete blocks LAC	≥ 0,88	≥ 5	0,25	0,3	1,0	1,0

LTX-8, LMX-8, LGX-8, LTX-10, LMX-10, LGX-10

Performances
Displacements

Annex C 4