

Approval body for construction products  
and types of construction

Bautechnisches Prüfamt

An institution established by the Federal and  
Laender Governments



## European Technical Assessment

**ETA-16/0958**  
**of 11 April 2017**

English translation prepared by DIBt - Original version in German language

### General Part

Technical Assessment Body issuing the  
European Technical Assessment:

Deutsches Institut für Bautechnik

Trade name of the construction product

B+BTec Injection system BIS-HY for concrete

Product family  
to which the construction product belongs

Bonded anchor for use in concrete

Manufacturer

B+BTec  
Munterij 8  
4762 AH ZEVENBERGEN  
NIEDERLANDE

Manufacturing plant

B+BTec Plant 1

This European Technical Assessment  
contains

24 pages including 3 annexes which form an integral part  
of this assessment

This European Technical Assessment is  
issued in accordance with Regulation (EU)  
No 305/2011, on the basis of

Guideline for European technical approval of "Metal  
anchors for use in concrete", ETAG 001 Part 5: "Bonded  
anchors", April 2013,  
used as European Assessment Document (EAD)  
according to Article 66 Paragraph 3 of Regulation (EU)  
No 305/2011.

This version replaces

ETA-16/0958 issued on 20 February 2017

The European Technical Assessment is issued by the Technical Assessment Body in its official language. Translations of this European Technical Assessment in other languages shall fully correspond to the original issued document and shall be identified as such.

Communication of this European Technical Assessment, including transmission by electronic means, shall be in full. However, partial reproduction may only be made with the written consent of the issuing Technical Assessment Body. Any partial reproduction shall be identified as such.

This European Technical Assessment may be withdrawn by the issuing Technical Assessment Body, in particular pursuant to information by the Commission in accordance with Article 25(3) of Regulation (EU) No 305/2011.

## Specific Part

### 1 Technical description of the product

The "B+BTec Injection system BIS-HY for concrete" is a bonded anchor consisting of a cartridge with injection mortar BIS-HY and a steel element. The steel element consist of a commercial threaded rod with washer and hexagon nut in the range of M8 to M30, reinforcing bar in the range of diameter  $\varnothing 8$  to  $\varnothing 32$  mm or internal threaded rod IG-M6 to IG-M20.

The steel element is placed into a drilled hole filled with injection mortar and is anchored via the bond between metal part, injection mortar and concrete.

The product description is given in Annex A.

### 2 Specification of the intended use in accordance with the applicable European Assessment Document

The performances given in Section 3 are only valid if the anchor is used in compliance with the specifications and conditions given in Annex B.

The verifications and assessment methods on which this European Technical Assessment is based lead to the assumption of a working life of the anchor of at least 50 years. The indications given on the working life cannot be interpreted as a guarantee given by the producer, but are to be regarded only as a means for choosing the right products in relation to the expected economically reasonable working life of the works.

### 3 Performance of the product and references to the methods used for its assessment

#### 3.1 Mechanical resistance and stability (BWR 1)

| Essential characteristic   | Performance           |
|--|-----------------------|
| Characteristic resistance for static and quasi-static action and seismic performance categories C1, C2 | See Annex C 1 to C 7  |
| Displacements  | See Annex C 8 to C 10 |

#### 3.2 Safety in case of fire (BWR 2)

| Essential characteristic | Performance                                 |
|--------------------------|---|
| Reaction to fire         | Anchorage satisfy requirements for Class A1 |
| Resistance to fire       | No performance assessed                     |

#### 3.3 Hygiene, health and the environment (BWR 3)

Regarding dangerous substances there may be requirements (e.g. transposed European legislation and national laws, regulations and administrative provisions) applicable to the products falling within the scope of this European Technical Assessment. In order to meet the provisions of Regulation (EU) No 305/2011, these requirements need also to be complied with, when and where they apply.

#### 3.4 Safety in use (BWR 4)

The essential characteristics regarding Safety in use are included under the Basic Works Requirement Mechanical resistance and stability.

English translation prepared by DIBt

**4 Assessment and verification of constancy of performance (AVCP) system applied, with reference to its legal base**

In accordance with guideline for European technical approval ETAG 001, April 2013 used as European Assessment Document (EAD) according to Article 66 Paragraph 3 of Regulation (EU) No 305/2011 the applicable European legal act is: [96/582/EC].

The system to be applied is: 1

**5 Technical details necessary for the implementation of the AVCP system, as provided for in the applicable EAD**

Technical details necessary for the implementation of the AVCP system are laid down in the control plan deposited with Deutsches Institut für Bautechnik.

Issued in Berlin on 11 April 2017 by Deutsches Institut für Bautechnik

Uwe Bender  
Head of Department

*beglaubigt:*  
Baderschneider

### Installation threaded rod M8 to M30

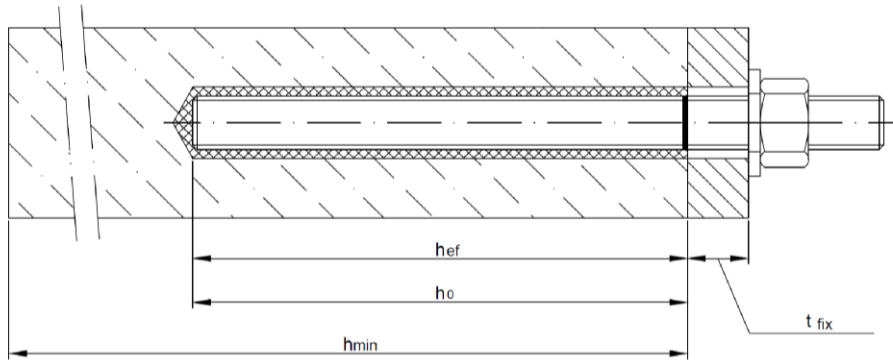

### Installation reinforcing bar Ø8 to Ø32

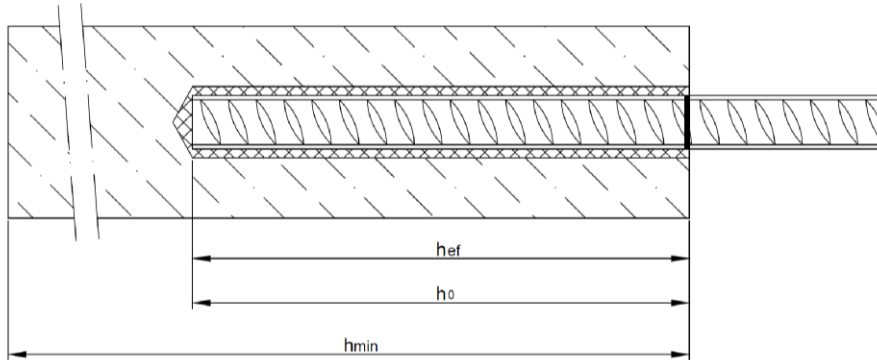

### Installation internal threaded rod IG-M6 to IG-M20

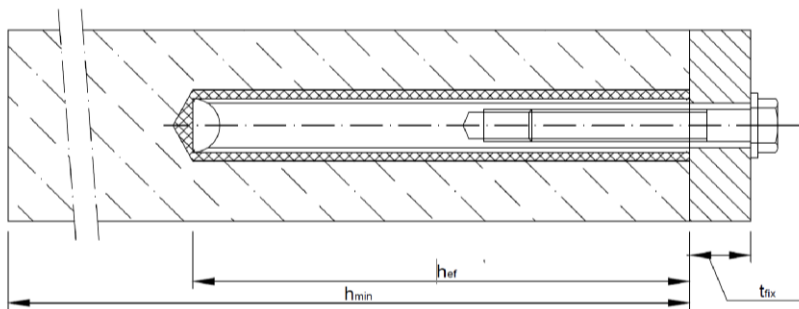

- $t_{fix}$  = thickness of fixture
- $h_{ef}$  = effective anchorage depth
- $h_0$  = depth of drill hole
- $h_{min}$  = minimum thickness of member

**B+BTec Injection System BIS-HY for concrete**

**Product description**  
Installed condition

**Annex A 1**

**Cartridge: BIS-HY**

150 ml, 280 ml, 300 ml up to 333 ml and 380 ml up to 420 ml cartridge (Type: coaxial)

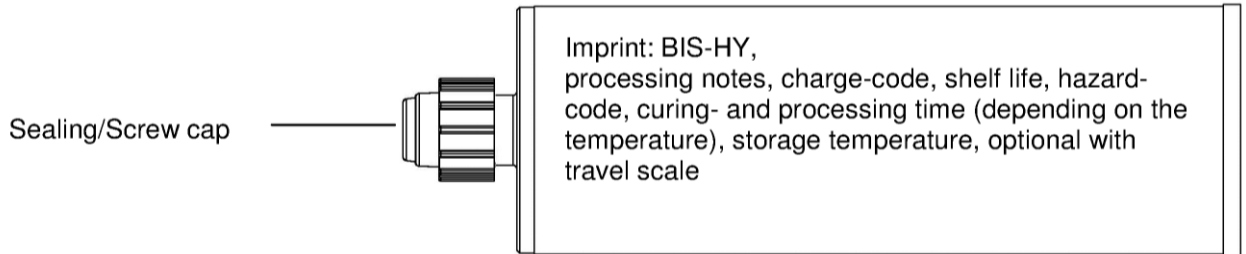

235 ml, 345 ml up to 360 ml and 825 ml cartridge (Type: "side-by-side")

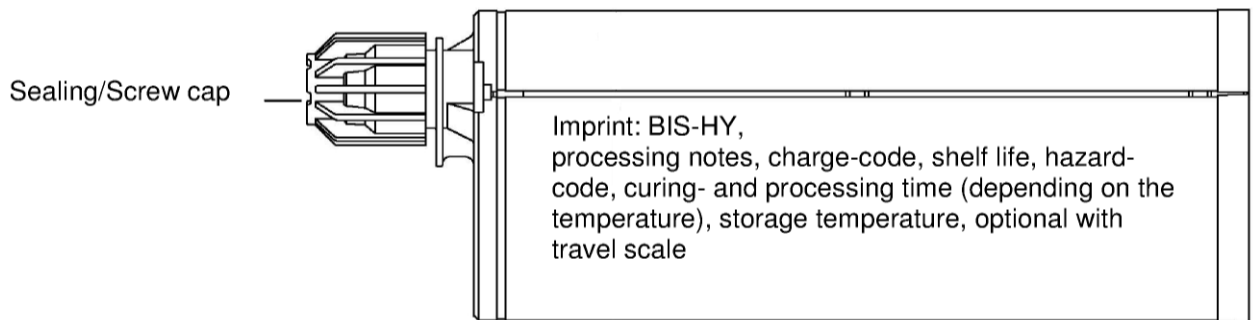

**Static Mixer**

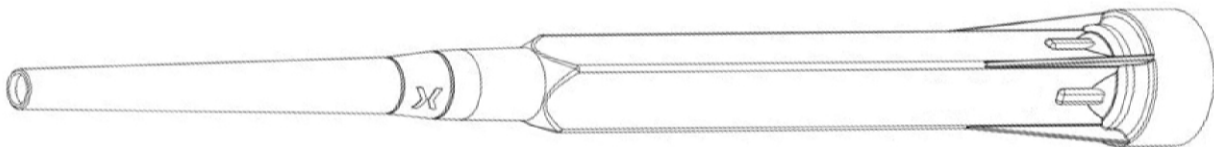

**B+BTec Injection System BIS-HY for concrete**

**Product description**  
Injection system

**Annex A 2**

### Threaded rod M8, M10, M12, M16, M20, M24, M27, M30 with washer and hexagon nut

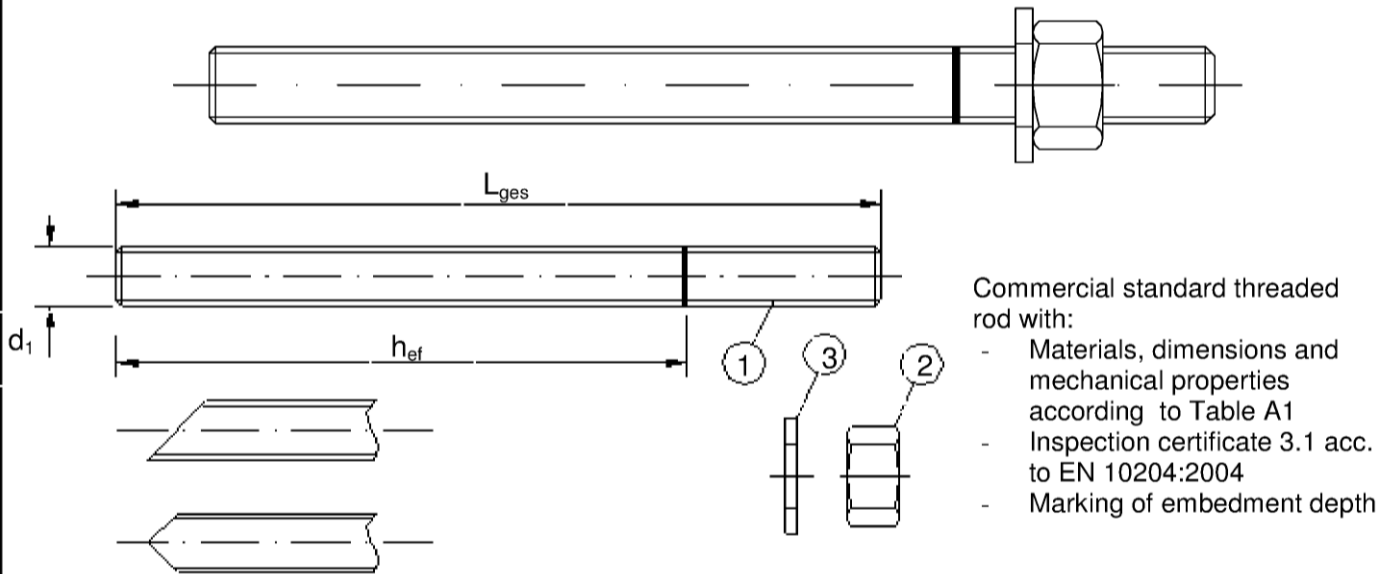

### Internal Threaded Sleeve IG-M6, IG-M8, IG-M10, IG-M12, IG-M16, IG-M20

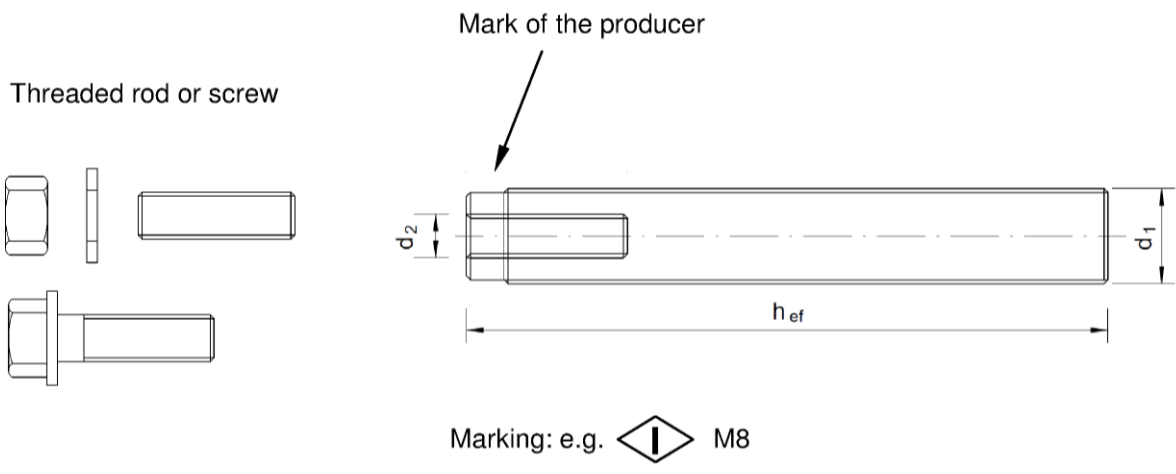

### Reinforcing bar $\varnothing$ 8, $\varnothing$ 10, $\varnothing$ 12, $\varnothing$ 14, $\varnothing$ 16, $\varnothing$ 20, $\varnothing$ 25, $\varnothing$ 28, $\varnothing$ 32

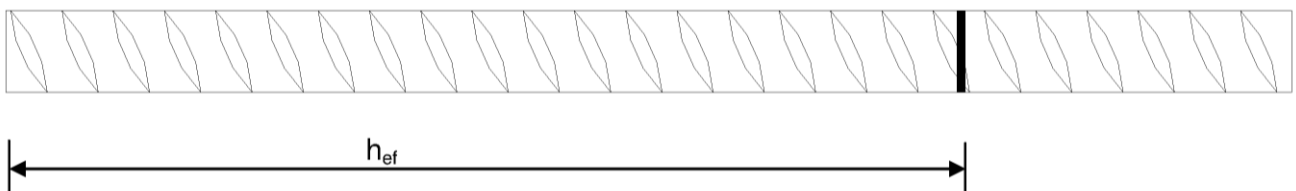

- Minimum value of related rip area  $f_{R,min}$  according to EN 1992-1-1:2004+AC:2010
- Rip height of the bar shall be in the range  $0,05d \leq h \leq 0,07d$   
(d: Nominal diameter of the bar; h: Rip height of the bar)

### B+BTec Injection System BIS-HY for concrete

#### Product description

Threaded rod, Internal threaded sleeve and reinforcing bar

### Annex A 3

| <b>Table A1: Materials</b>  |  |
|---|--|
| <b>Designation</b>  | <b>Material</b>  |
| <b>Steel, zinc plated <math>\geq 5 \mu\text{m}</math> acc. to EN ISO 4042:1999 or Steel, hot-dip galvanised <math>\geq 40 \mu\text{m}</math> acc. to EN ISO 1461:2009 and EN ISO 10684:2004+AC:2009</b> |  |
| Anchor rod  | Steel, EN 10087:1998 or EN 10263:2001<br>Property class 4.6, 4.8, 5.6, 5.8, 8.8, EN 1993-1-8:2005+AC:2009<br>$A_5 > 12\%$ fracture elongation  |
| Hexagon nut, EN ISO 4032:2012   | Steel acc. to EN 10087:1998 or EN 10263:2001<br>Property class 4 (for class 4.6 and 4.8 rod) EN ISO 898-2:2012,<br>Property class 5 (for class 5.6 and 5.8 rod) EN ISO 898-2:2012,<br>Property class 8 (for class 8.8 rod) EN ISO 898-2:2012 |
| Washer, EN ISO 887:2006, EN ISO 7089:2000, EN ISO 7093:2000 or EN ISO 7094:2000   | Steel, zinc plated<br>Property class 5.6, 5.8 and 8.8 EN ISO 898-1:2013  |
| Internal threaded rod   | Steel, zinc plated   |
| <b>Stainless steel</b>  |  |
| Anchor rod  | Material 1.4401 / 1.4404 / 1.4571, EN 10088-1:2005,<br>> M24: Property class 50 EN ISO 3506-1:2009<br>$\leq$ M24: Property class 70 EN ISO 3506-1:2009<br>$A_5 > 12\%$ fracture elongation   |
| Hexagon nut, EN ISO 4032:2012   | Material 1.4401 / 1.4404 / 1.4571 EN 10088:2005,<br>> M24: Property class 50 (for class 50 rod) EN ISO 3506-2:2009<br>$\leq$ M24: Property class 70 (for class 70 rod) EN ISO 3506-2:2009  |
| Washer, EN ISO 887:2006, EN ISO 7089:2000, EN ISO 7093:2000 or EN ISO 7094:2000   | Material 1.4401, 1.4404 or 1.4571, EN 10088-1:2005   |
| Internal threaded rod   | Stainless steel: 1.4401 / 1.4404 / 1.4571, EN 10088-1:2014<br>Property class 70 (for class 70 rod) EN ISO 3506-1:2009  |
| <b>High corrosion resistant steel</b>   |  |
| Anchor rod  | Material 1.4529 / 1.4565, EN 10088-1:2005,<br>> M24: Property class 50 EN ISO 3506-1:2009<br>$\leq$ M24: Property class 70 EN ISO 3506-1:2009<br>$A_5 > 12\%$ fracture elongation  |
| Hexagon nut, EN ISO 4032:2012   | Material 1.4529 / 1.4565 EN 10088-1:2005,<br>> M24: Property class 50 (for class 50 rod) EN ISO 3506-2:2009<br>$\leq$ M24: Property class 70 (for class 70 rod) EN ISO 3506-2:2009   |
| Washer, EN ISO 887:2006, EN ISO 7089:2000, EN ISO 7093:2000 or EN ISO 7094:2000   | Material 1.4529 / 1.4565, EN 10088-1:2005  |
| Internal threaded rod   | Stainless steel: 1.4529 / 1.4565, EN 10088-1:2014<br>Property class 70 (for class 70 rod) EN ISO 3506-1:2009   |
| <b>Reinforcing bars</b>   |  |
| Rebar<br>EN 1992-1-1:2004+AC:2010, Annex C  | Bars and de-coiled rods class B or C<br>$f_{yk}$ and $k$ according to NDP or NCL of EN 1992-1-1/NA:2013<br>$f_{tk} = f_{tk} = k \cdot f_{yk}$  |
| <b>B+BTec Injection System BIS-HY for concrete</b>  |  |
| <b>Product description</b><br>Materials   | <b>Annex A 4</b>   |



## Specifications of intended use

### Anchorage subject to:

- Static and quasi-static loads: M8 to M30, Rebar Ø8 to Ø32, IG-M6 to IG-M20.
- Seismic action for Performance Category C1: M8 to M30, Rebar Ø8 to Ø32.
- Seismic action for Performance Category C2: M12

### Base materials:

- Reinforced or unreinforced normal weight concrete according to EN 206-1:2000.
- Strength classes C20/25 to C50/60 according to EN 206-1:2000.
- Non-cracked concrete: M8 to M30, Rebar Ø8 to Ø32, IG-M6 to IG-M20.
- Cracked concrete: M8 to M30, Rebar Ø8 to Ø32, IG-M6 to IG-M20.

### Temperature Range:

- I: - 40 °C to +80 °C (max long term temperature +50 °C and max short term temperature +80 °C)
- II: - 40 °C to +120 °C (max long term temperature +72 °C and max short term temperature +120 °C)
- III: - 40 °C to +160 °C (max long term temperature +100 °C and max short term temperature +160 °C)

### Use conditions (Environmental conditions):

- Structures subject to dry internal conditions (zinc coated steel, stainless steel or high corrosion resistant steel).
- Structures subject to external atmospheric exposure (including industrial and marine environment) and to permanently damp internal condition, if no particular aggressive conditions exist (stainless steel or high corrosion resistant steel).
- Structures subject to external atmospheric exposure and to permanently damp internal condition, if other particular aggressive conditions exist (high corrosion resistant steel).

Note: Particular aggressive conditions are e.g. permanent, alternating immersion in seawater or the splash zone of seawater, chloride atmosphere of indoor swimming pools or atmosphere with extreme chemical pollution (e.g. in desulphurization plants or road tunnels where de-icing materials are used).

### Design:

- Verifiable calculation notes and drawings are prepared taking account of the loads to be anchored. The position of the anchor is indicated on the design drawings (e. g. position of the anchor relative to reinforcement or to supports, etc.).
- Anchorages are designed under the responsibility of an engineer experienced in anchorages and concrete work.
- Anchorages under static or quasi-static actions are designed in accordance with:
  - EOTA Technical Report TR 029 "Design of bonded anchors", Edition September 2010 or
  - CEN/TS 1992-4:2009
- Anchorages under seismic actions (cracked concrete) are designed in accordance with:
  - EOTA Technical Report TR 045 "Design of Metal Anchors under Seismic Action", Edition February 2013
  - Anchorages shall be positioned outside of critical regions (e.g. plastic hinges) of the concrete structure.
  - Fastenings in stand-off installation or with a grout layer are not allowed.

### Installation:

- Dry or wet concrete.
- Hole drilling by hammer or compressed air drill mode.
- Overhead installation allowed.
- Anchor installation carried out by appropriately qualified personnel and under the supervision of the person responsible for technical matters of the site.
- Fastening screws or threaded rods (incl. nut and washer) must comply with the appropriate material and property class of the Internal threaded rod.

## B+BTec Injection System BIS-HY for concrete

Intended Use  
Specifications

Annex B 1

**Table B1: Installation parameters for threaded rod**

| Anchor size   |                        | M 8                          | M 10 | M 12             | M 16            | M 20 | M 24 | M 27 | M 30 |
|---|------------------------|------------------------------|------|------------------|-----------------|------|------|------|------|
| Diameter of element                                     | $d_1 = d_{nom}$ [mm] = | 8                            | 10   | 12               | 16              | 20   | 24   | 27   | 30   |
| Nominal drill hole diameter                             | $d_0$ [mm] =           | 10                           | 12   | 14               | 18              | 22   | 28   | 30   | 35   |
| Effective anchorage depth                               | $h_{ef,min}$ [mm] =    | 60                           | 60   | 70               | 80              | 90   | 96   | 108  | 120  |
|   | $h_{ef,max}$ [mm] =    | 160                          | 200  | 240              | 320             | 400  | 480  | 540  | 600  |
| Diameter of clearance hole in the fixture <sup>1)</sup> | $d_f$ [mm] =           | 9                            | 12   | 14               | 18              | 22   | 26   | 30   | 33   |
| Installation torque                                     | $T_{inst}$ [Nm] ≤      | 10                           | 20   | 40 <sup>2)</sup> | 60              | 100  | 170  | 250  | 300  |
| Minimum thickness of member                             | $h_{min}$ [mm]         | $h_{ef} + 30$ mm<br>≥ 100 mm |      |                  | $h_{ef} + 2d_0$ |      |      |      |      |
| Minimum spacing   | $s_{min}$ [mm]         | 40                           | 50   | 60               | 75              | 95   | 115  | 125  | 140  |
| Minimum edge distance                                   | $c_{min}$ [mm]         | 35                           | 40   | 45               | 50              | 60   | 65   | 75   | 80   |

<sup>1)</sup> For larger clearance hole see TR029 section 1.1; for application under seismic loading the diameter of clearance hole in the fixture shall be at maximum  $d_1 + 1$  mm or alternatively the annular gap between fixture and anchor rod shall be filled force-fit with mortar.

<sup>2)</sup> Maximum Torque moment for M12 with steel Grade 4.6 is 35 Nm

**Table B2: Installation parameters for rebar**

| Rebar size                  |                      | Ø 8                          | Ø 10 | Ø 12 | Ø 14            | Ø 16 | Ø 20 | Ø 25 | Ø 28 | Ø 32 |
|-----------------------------|----------------------|------------------------------|------|------|-----------------|------|------|------|------|------|
| Diameter of element         | $d = d_{nom}$ [mm] = | 8                            | 10   | 12   | 14              | 16   | 20   | 25   | 28   | 32   |
| Nominal drill hole diameter | $d_0$ [mm] =         | 12                           | 14   | 16   | 18              | 20   | 25   | 32   | 35   | 40   |
| Effective anchorage depth   | $h_{ef,min}$ [mm] =  | 60                           | 60   | 70   | 75              | 80   | 90   | 100  | 112  | 128  |
|                             | $h_{ef,max}$ [mm] =  | 160                          | 200  | 240  | 280             | 320  | 400  | 500  | 560  | 640  |
| Minimum thickness of member | $h_{min}$ [mm]       | $h_{ef} + 30$ mm<br>≥ 100 mm |      |      | $h_{ef} + 2d_0$ |      |      |      |      |      |
| Minimum spacing             | $s_{min}$ [mm]       | 40                           | 50   | 60   | 70              | 75   | 95   | 120  | 130  | 150  |
| Minimum edge distance       | $c_{min}$ [mm]       | 35                           | 40   | 45   | 50              | 50   | 60   | 70   | 75   | 85   |

**Table B3: Installation parameters for Internal threaded rod**

| Anchor size   |                        | IG-M 6                       | IG-M 8 | IG-M 10 | IG-M 12         | IG-M 16 | IG-M 20 |
|---|------------------------|------------------------------|--------|---------|-----------------|---------|---------|
| Internal diameter of sleeve                             | $d_2$ [mm] =           | 6                            | 8      | 10      | 12              | 16      | 20      |
| Outer diameter of sleeve <sup>2)</sup>                  | $d_1 = d_{nom}$ [mm] = | 10                           | 12     | 16      | 20              | 24      | 30      |
| Nominal drill hole diameter                             | $d_0$ [mm] =           | 12                           | 14     | 18      | 22              | 28      | 35      |
| Effective anchorage depth                               | $h_{ef,min}$ [mm] =    | 60                           | 70     | 80      | 90              | 96      | 120     |
|   | $h_{ef,max}$ [mm] =    | 200                          | 240    | 320     | 400             | 480     | 600     |
| Diameter of clearance hole in the fixture <sup>1)</sup> | $d_f$ [mm] =           | 7                            | 9      | 12      | 14              | 18      | 22      |
| Installation torque                                     | $T_{inst}$ [Nm] ≤      | 10                           | 10     | 20      | 40              | 60      | 100     |
| Thread engagement length Min/max                        | $l_{IG}$ [mm] =        | 8/20                         | 8/20   | 10/25   | 12/30           | 16/32   | 20/40   |
| Minimum thickness of member                             | $h_{min}$ [mm]         | $h_{ef} + 30$ mm<br>≥ 100 mm |        |         | $h_{ef} + 2d_0$ |         |         |
| Minimum spacing   | $s_{min}$ [mm]         | 50                           | 60     | 75      | 95              | 115     | 125     |
| Minimum edge distance                                   | $c_{min}$ [mm]         | 40                           | 45     | 50      | 60              | 65      | 75      |

<sup>1)</sup> For larger clearance hole see TR029 section 1.1



<sup>2)</sup> With metric threads according to EN 1993-1-8:2005+AC:2009

**B+BTec Injection System BIS-HY for concrete**

**Intended Use**  
Installation parameters

**Annex B 2**

**Table B4: Parameter cleaning and setting tools**

| Threaded Rod | Rebar | Internal threaded rod | $d_0$<br>Drill bit - $\varnothing$ | $d_b$<br>Brush - $\varnothing$ |      | $d_{b,min}$<br>min.<br>Brush - $\varnothing$ | Piston plug | Installation direction and use of piston plug                                       |   |   |
|--------------|-------|-----------------------|------------------------------------|--------------------------------|------|--|-------------|---|---|---|
|              |       |                       |                                    | (mm)                           | (mm) |  |             |  |  |  |
| M8           |       |                       | 10                                 | RB10                           | 11,5 | 10,5   | -           | -   | -   | -   |
| M10          | 8     | IG-M6                 | 12                                 | RB12                           | 13,5 | 12,5   | -           | -   | -   | -   |
| M12          | 10    | IG-M8                 | 14                                 | RB14                           | 15,5 | 14,5   | -           | -   | -   | -   |
|              | 12    |                       | 16                                 | RB16                           | 17,5 | 16,5   | -           | -   | -   | -   |
| M16          | 14    | IG-M10                | 18                                 | RB18                           | 20,0 | 18,5   | VS18        | $h_{ef} > 250$ mm   | $h_{ef} > 250$ mm   | all   |
|              | 16    |                       | 20                                 | RB20                           | 22,0 | 20,5   | VS20        |   |   |   |
| M20          |       | IG-M12                | 22                                 | RB22                           | 24,0 | 22,5   | VS22        |   |   |   |
|              | 20    |                       | 25                                 | RB25                           | 27,0 | 25,5   | VS25        |   |   |   |
| M24          |       | IG-M16                | 28                                 | RB28                           | 30,0 | 28,5   | VS28        |   |   |   |
| M27          |       |                       | 30                                 | RB30                           | 31,8 | 30,5   | VS30        |   |   |   |
|              | 25    |                       | 32                                 | RB32                           | 34,0 | 32,5   | VS32        |   |   |   |
| M30          | 28    | IG-M20                | 35                                 | RB35                           | 37,0 | 35,5   | VS35        |   |   |   |
|              | 32    |                       | 40                                 | RB40                           | 43,5 | 40,5   | VS40        |   |   |   |



**MAC - Hand pump (volume 750 ml)**  
Drill bit diameter ( $d_0$ ): 10 mm to 20 mm  
Drill hole depth ( $h_0$ ):  $< 10 d_s$   
Only in non-cracked concrete



**CAC - Rec. compressed air tool (min 6 bar)**  
Drill bit diameter ( $d_0$ ): all diameters



**Piston plug for overhead or horizontal installation VS**  
Drill bit diameter ( $d_0$ ): 18 mm to 40 mm

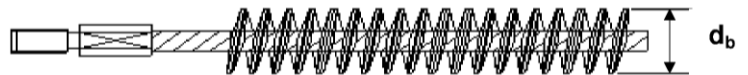

**Steel brush RB**  
Drill bit diameter ( $d_0$ ): all diameters

**B+BTec Injection System BIS-HY for concrete**

**Intended Use**  
Cleaning and setting tools

**Annex B 3**

## Installation instructions

### Drilling of the bore hole

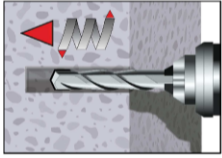

1. Drill with hammer drill a hole into the base material to the size and embedment depth required by the selected anchor (Table B1, B2, or B3). In case of aborted drill hole: the drill hole shall be filled with mortar

**Attention! Standing water in the bore hole must be removed before cleaning.**

### MAC: Cleaning for bore hole diameter $d_0 \leq 20\text{mm}$ and bore hole depth $h_0 \leq 10d_s$ (uncracked concrete only!)

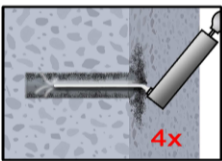

- 2a. Starting from the bottom or back of the bore hole, blow the hole clean by a hand pump (Annex B 3) a minimum of four times.

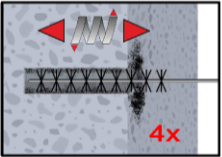

- 2b. Check brush diameter (Table B4). Brush the hole with an appropriate sized wire brush  $> d_{b,\text{min}}$  (Table B4) a minimum of four times in a twisting motion. If the bore hole ground is not reached with the brush, a brush extension must be used.

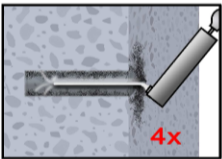

- 2c. Finally blow the hole clean again with a hand pump (Annex B 3) a minimum of four times.

### CAC: Cleaning for all bore hole diameter in uncracked and cracked concrete

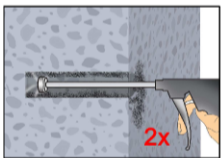

- 2a. Starting from the bottom or back of the bore hole, blow the hole clean with compressed air (min. 6 bar) (Annex B 3) a minimum of two times until return air stream is free of noticeable dust. If the bore hole ground is not reached an extension must be used.

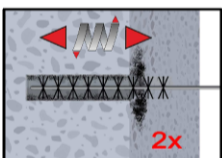

- 2b. Check brush diameter (Table B4). Brush the hole with an appropriate sized wire brush  $> d_{b,\text{min}}$  (Table B4) a minimum of two times. If the bore hole ground is not reached with the brush, a brush extension must be used.

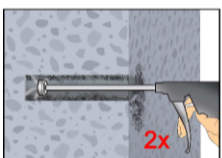

- 2c. Finally blow the hole clean again with compressed air (min. 6 bar) (Annex B 3) a minimum of two times until return air stream is free of noticeable dust. If the bore hole ground is not reached an extension must be used.

**After cleaning, the bore hole has to be protected against re-contamination in an appropriate way, until dispensing the mortar in the bore hole. If necessary, the cleaning has to be repeated directly before dispensing the mortar. In-flowing water must not contaminate the bore hole again.**

### B+BTec Injection System BIS-HY for concrete

Intended Use  
Installation instructions

**Annex B 4**



### Installation instructions (continuation)

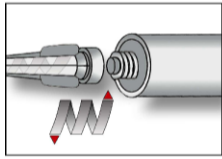

3. Attach the supplied static-mixing nozzle to the cartridge and load the cartridge into the correct dispensing tool.  
For every working interruption longer than the recommended working time (Table B5) as well as for new cartridges, a new static-mixer shall be used.

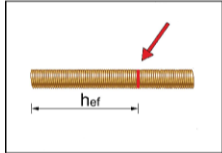

4. Prior to inserting the anchor rod into the filled bore hole, the position of the embedment depth shall be marked on the anchor rods.

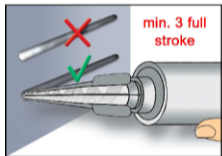

5. Prior to dispensing into the anchor hole, squeeze out separately a minimum of three full strokes and discard non-uniformly mixed adhesive components until the mortar shows a consistent grey colour.

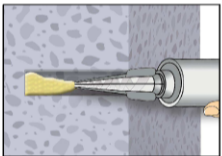

6. Starting from the bottom or back of the cleaned anchor hole, fill the hole up to approximately two-thirds with adhesive. Slowly withdraw the static mixing nozzle as the hole fills to avoid creating air pockets. For embedment larger than 190 mm an extension nozzle shall be used. Observe the gel-/ working times given in Table B5.

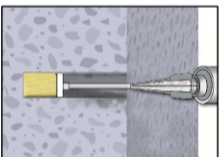

7. Piston Plugs and mixer nozzle extensions shall be used according to Table B4 for the following applications:
- Horizontal assembly (horizontal direction) and ground erection (vertical downwards direction): Drill bit- $\varnothing d_0 \geq 18$  mm and embedment depth  $h_{ef} > 250$ mm
  - Overhead assembly (vertical upwards direction): Drill bit- $\varnothing d_0 \geq 18$  mm

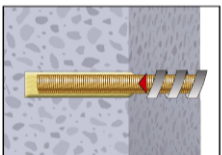

8. Push the threaded rod or reinforcing bar into the anchor hole while turning slightly to ensure positive distribution of the adhesive until the embedment depth is reached.

The anchor shall be free of dirt, grease, oil or other foreign material.

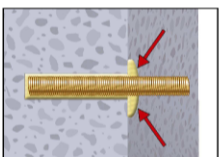

9. Be sure that the anchor is fully seated at the bottom of the hole and that excess mortar is visible at the top of the hole. If these requirements are not maintained, the application has to be renewed. For overhead application the anchor rod shall be fixed (e.g. wedges).

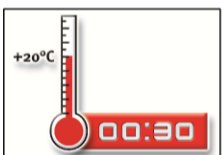

10. Allow the adhesive to cure to the specified time prior to applying any load or torque. Do not move or load the anchor until it is fully cured (attend Table B5).

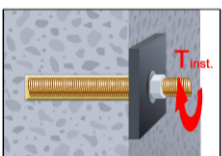

11. After full curing, the add-on part can be installed with up to the max. torque (Table B1 or B3) by using a calibrated torque wrench.

### B+BTec Injection System BIS-HY for concrete

#### Intended Use

Installation instructions (continuation)

Annex B 5

**Table B5: Maximum working time and minimum curing time**

| Concrete temperature  | Gelling working time | Minimum curing time in dry concrete | Minimum curing time in wet concrete |
|-----------------------|----------------------|-------------------------------------|-------------------------------------|
| - 5 °C to - 1 °C      | 50 min               | 5 h                                 | 10 h                                |
| 0 °C to + 4 °C        | 25 min               | 3,5 h                               | 7 h                                 |
| + 5 °C to + 9 °C      | 15 min               | 2 h                                 | 4 h                                 |
| + 10 °C to + 14 °C    | 10 min               | 1 h                                 | 2 h                                 |
| + 15 °C to + 19 °C    | 6 min                | 40 min                              | 80 min                              |
| + 20 °C to + 29 °C    | 3 min                | 30 min                              | 60 min                              |
| + 30 °C to + 40 °C    | 2 min                | 30 min                              | 60 min                              |
| Cartridge temperature | +5°C to +40°C        |                                     |                                     |

**B+BTec Injection System BIS-HY for concrete**

**Intended Use**  
Curing time

**Annex B 6**

**Table C1: Characteristic values for steel tension resistance and steel shear resistance of threaded rods**

| Size  |   |            | M 8  | M 10 | M 12 | M 16 | M 20 | M 24 | M 27 | M 30 |      |
|---|---|------------|------|------|------|------|------|------|------|------|------|
| <b>Characteristic tension resistance, Steel failure</b>         |   |            |      |      |      |      |      |      |      |      |      |
| Steel, Property class 4.6 and 4.8                               | $N_{Rk,s}$                                    | [kN]       | 15   | 23   | 34   | 63   | 98   | 141  | 184  | 224  |      |
| Steel, Property class 5.6 and 5.8                               | $N_{Rk,s}$                                    | [kN]       | 18   | 29   | 42   | 78   | 122  | 176  | 230  | 280  |      |
| Steel, Property class 8.8                                       | $N_{Rk,s}$                                    | [kN]       | 29   | 46   | 67   | 125  | 196  | 282  | 368  | 449  |      |
| Nichtrostender Stahl A4 and HCR, Property class 50              | $N_{Rk,s}$                                    | [kN]       | 18   | 29   | 42   | 79   | 123  | 177  | 230  | 281  |      |
| Nichtrostender Stahl A4 and HCR, Property class 70              | $N_{Rk,s}$                                    | [kN]       | 26   | 41   | 59   | 110  | 171  | 247  | -    | -    |      |
| <b>Characteristic tension resistance, Partial safety factor</b> |   |            |      |      |      |      |      |      |      |      |      |
| Steel, Property class 4.6                                       | $\gamma_{Ms,N}^{1)}$                          | [-]        |      |      |      | 2,0  |      |      |      |      |      |
| Steel, Property class 4.8                                       | $\gamma_{Ms,N}^{1)}$                          | [-]        |      |      |      | 1,5  |      |      |      |      |      |
| Steel, Property class 5.6                                       | $\gamma_{Ms,N}^{1)}$                          | [-]        |      |      |      | 2,0  |      |      |      |      |      |
| Steel, Property class 5.8                                       | $\gamma_{Ms,N}^{1)}$                          | [-]        |      |      |      | 1,5  |      |      |      |      |      |
| Steel, Property class 8.8                                       | $\gamma_{Ms,N}^{1)}$                          | [-]        |      |      |      | 1,5  |      |      |      |      |      |
| Stainless steel A4 and HCR, Property class 50                   | $\gamma_{Ms,N}^{1)}$                          | [-]        |      |      |      | 2,86 |      |      |      |      |      |
| Stainless steel A4 and HCR, Property class 70                   | $\gamma_{Ms,N}^{1)}$                          | [-]        |      |      |      | 1,87 |      |      |      |      |      |
| <b>Characteristic shear resistance, Steel failure</b>           |   |            |      |      |      |      |      |      |      |      |      |
| Without lever arm   | Steel, Property class 4.6 and 4.8             | $V_{Rk,s}$ | [kN] | 7    | 12   | 17   | 31   | 49   | 71   | 92   | 112  |
|   | Steel, Property class 5.6 and 5.8             | $V_{Rk,s}$ | [kN] | 9    | 15   | 21   | 39   | 61   | 88   | 115  | 140  |
|   | Steel, Property class 8.8                     | $V_{Rk,s}$ | [kN] | 15   | 23   | 34   | 63   | 98   | 141  | 184  | 224  |
|   | Stainless steel A4 and HCR, Property class 50 | $V_{Rk,s}$ | [kN] | 9    | 15   | 21   | 39   | 61   | 88   | 115  | 140  |
|   | Stainless steel A4 and HCR, Property class 70 | $V_{Rk,s}$ | [kN] | 13   | 20   | 30   | 55   | 86   | 124  | -    | -    |
| With lever arm  | Steel, Property class 4.6 and 4.8             | $M_{Rk,s}$ | [Nm] | 15   | 30   | 52   | 133  | 260  | 449  | 666  | 900  |
|   | Steel, Property class 5.6 and 5.8             | $M_{Rk,s}$ | [Nm] | 19   | 37   | 65   | 166  | 324  | 560  | 833  | 1123 |
|   | Steel, Property class 8.8                     | $M_{Rk,s}$ | [Nm] | 30   | 60   | 105  | 266  | 519  | 896  | 1333 | 1797 |
|   | Stainless steel A4 and HCR, Property class 50 | $M_{Rk,s}$ | [Nm] | 19   | 37   | 66   | 167  | 325  | 561  | 832  | 1125 |
|   | Stainless steel A4 and HCR, Property class 70 | $M_{Rk,s}$ | [Nm] | 26   | 52   | 92   | 232  | 454  | 784  | -    | -    |
| <b>Characteristic shear resistance, Partial safety factor</b>   |   |            |      |      |      |      |      |      |      |      |      |
| Steel, Property class 4.6                                       | $\gamma_{Ms,V}^{1)}$                          | [-]        |      |      |      | 1,67 |      |      |      |      |      |
| Steel, Property class 4.8                                       | $\gamma_{Ms,V}^{1)}$                          | [-]        |      |      |      | 1,25 |      |      |      |      |      |
| Steel, Property class 5.6                                       | $\gamma_{Ms,V}^{1)}$                          | [-]        |      |      |      | 1,67 |      |      |      |      |      |
| Steel, Property class 5.8                                       | $\gamma_{Ms,V}^{1)}$                          | [-]        |      |      |      | 1,25 |      |      |      |      |      |
| Steel, Property class 8.8                                       | $\gamma_{Ms,V}^{1)}$                          | [-]        |      |      |      | 1,25 |      |      |      |      |      |
| Stainless steel A4 and HCR, Property class 50                   | $\gamma_{Ms,V}^{1)}$                          | [-]        |      |      |      | 2,38 |      |      |      |      |      |
| Stainless steel A4 and HCR, Property class 70                   | $\gamma_{Ms,V}^{1)}$                          | [-]        |      |      |      | 1,56 |      |      |      |      |      |

<sup>1)</sup> in absence of national regulation

**B+BTec Injection System BIS-HY for concrete**

**Performances**

Characteristic values for steel tension resistance and steel shear resistance of threaded rods

**Annex C 1**

**Table C2: Characteristic values of tension loads for threaded rods under static, quasi-static action and seismic action (performance category C1+C2)**

| Anchor size threaded rod  |                            |                               |                      | M 8  | M 10                            | M 12 | M 16 | M 20 | M 24 | M 27             | M 30 |
|---|----------------------------|-------------------------------|----------------------|--|---------------------------------|------|------|------|------|------------------|------|
| <b>Steel failure</b>  |                            |                               |                      |  |                                 |      |      |      |      |                  |      |
| Characteristic tension resistance   | $N_{Rk,s}$                 | [kN]                          | see Table C1         |  |                                 |      |      |      |      |                  |      |
|   | $N_{Rk,s,C1}$              | [kN]                          | $1,0 \cdot N_{Rk,s}$ |  |                                 |      |      |      |      |                  |      |
|   | $N_{Rk,s,C2}$              | [kN]                          | NPD                  | $1,0 \cdot N_{Rk,s}$                                   | No Performance Determined (NPD) |      |      |      |      |                  |      |
| Partial safety factor   | $\gamma_{Ms,N}$            | [-]                           | see Table C1         |  |                                 |      |      |      |      |                  |      |
| <b>Combined pull-out and concrete cone failure</b>  |                            |                               |                      |  |                                 |      |      |      |      |                  |      |
| Characteristic bond resistance in non-cracked concrete C20/25   |                            |                               |                      |  |                                 |      |      |      |      |                  |      |
| Temperature range I:<br>80°C/50°C   | dry and wet concrete       | $\tau_{Rk,ucr}$               | [N/mm <sup>2</sup> ] | 17   | 17                              | 16   | 15   | 14   | 13   | 13               | 13   |
| Temperature range II:<br>120°C/72°C   | dry and wet concrete       | $\tau_{Rk,ucr}$               | [N/mm <sup>2</sup> ] | 15   | 14                              | 14   | 13   | 12   | 12   | 11               | 11   |
| Temperature range III:<br>160°C/100°C   | dry and wet concrete       | $\tau_{Rk,ucr}$               | [N/mm <sup>2</sup> ] | 12   | 12                              | 11   | 10   | 9,5  | 9,0  | 9,0              | 9,0  |
| Characteristic bond resistance in cracked concrete C20/25   |                            |                               |                      |  |                                 |      |      |      |      |                  |      |
| Temperature range I:<br>80°C/50°C   | dry and wet concrete       | $\tau_{Rk,cr} = \tau_{Rk,C1}$ | [N/mm <sup>2</sup> ] | 6,5  | 7,0                             | 7,5  | 8,5  | 8,5  | 8,5  | 8,5              | 8,5  |
|   |                            | $\tau_{Rk,C2}$                | [N/mm <sup>2</sup> ] | NPD  |                                 | 3,6  | NPD  |      |      |                  |      |
| Temperature range II:<br>120°C/72°C   | dry and wet concrete       | $\tau_{Rk,cr} = \tau_{Rk,C1}$ | [N/mm <sup>2</sup> ] | 5,5  | 6,0                             | 6,5  | 7,5  | 7,5  | 7,5  | 7,5              | 7,5  |
|   |                            | $\tau_{Rk,C2}$                | [N/mm <sup>2</sup> ] | NPD  |                                 | 3,1  | NPD  |      |      |                  |      |
| Temperature range III:<br>160°C/100°C   | dry and wet concrete       | $\tau_{Rk,cr} = \tau_{Rk,C1}$ | [N/mm <sup>2</sup> ] | 5,0  | 5,5                             | 6,0  | 6,5  | 6,5  | 6,5  | 6,5              | 6,5  |
|   |                            | $\tau_{Rk,C2}$                | [N/mm <sup>2</sup> ] | NPD  |                                 | 2,5  | NPD  |      |      |                  |      |
| Increasing factors for concrete<br>$\psi_c$   | C25/30                     |                               |                      | 1,02   |                                 |      |      |      |      |                  |      |
|   | C30/37                     |                               |                      | 1,04   |                                 |      |      |      |      |                  |      |
|   | C35/45                     |                               |                      | 1,07   |                                 |      |      |      |      |                  |      |
|   | C40/50                     |                               |                      | 1,08   |                                 |      |      |      |      |                  |      |
|   | C45/55                     |                               |                      | 1,09   |                                 |      |      |      |      |                  |      |
|   | C50/60                     |                               |                      | 1,10   |                                 |      |      |      |      |                  |      |
| Factor according to<br>CEN/TS 1992-4-5<br>Section 6.2.2.3   | Non-cracked concrete       | $k_8$                         | [-]                  | 10,1   |                                 |      |      |      |      |                  |      |
|   | Cracked concrete           |                               |                      | 7,2  |                                 |      |      |      |      |                  |      |
| <b>Concrete cone failure</b>  |                            |                               |                      |  |                                 |      |      |      |      |                  |      |
| Factor according to<br>CEN/TS 1992-4-5<br>Section 6.2.3.1   | Non-cracked concrete       | $k_{ucr}$                     | [-]                  | 10,1   |                                 |      |      |      |      |                  |      |
|   | Cracked concrete           | $k_{cr}$                      | [-]                  | 7,2  |                                 |      |      |      |      |                  |      |
| Edge distance   | $s_{cr,N}$                 |                               | [mm]                 | $1,5 h_{ef}$   |                                 |      |      |      |      |                  |      |
| Axial distance  | $s_{cr,N}$                 |                               | [mm]                 | $3,0 h_{ef}$   |                                 |      |      |      |      |                  |      |
| <b>Splitting failure</b>  |                            |                               |                      |  |                                 |      |      |      |      |                  |      |
| Edge distance   | $h/h_{ef} \geq 2,0$        | $s_{cr,sp}$                   | [mm]                 | $1,0 h_{ef}$   |                                 |      |      |      |      |                  |      |
|   | $2,0 > h/h_{ef} > 1,3$     |                               |                      | $2 \cdot h_{ef} \left( 2,5 - \frac{h}{h_{ef}} \right)$ |                                 |      |      |      |      |                  |      |
|   | $h/h_{ef} \leq 1,3$        |                               |                      | $2,4 h_{ef}$   |                                 |      |      |      |      |                  |      |
| Axial distance  | $s_{cr,sp}$                |                               | [mm]                 | $2 s_{cr,sp}$  |                                 |      |      |      |      |                  |      |
| Installation safety factor (CAC)<br>(dry and wet concrete)  | $\gamma_2 = \gamma_{inst}$ | [-]                           | $1,0 (1,2)^{1)}$     |  |                                 |      |      | 1,2  |      |                  |      |
| Installation safety factor (MAC)<br>(dry and wet concrete)  | $\gamma_2 = \gamma_{inst}$ | [-]                           | 1,2                  |  |                                 |      |      | -    |      |                  |      |
| <sup>1)</sup> Value in brackets for cracked concrete  |                            |                               |                      |  |                                 |      |      |      |      |                  |      |
| <b>B+BTec Injection System BIS-HY for concrete</b>  |                            |                               |                      |  |                                 |      |      |      |      | <b>Annex C 2</b> |      |
| <b>Performances</b><br>Characteristic values of tension loads for threaded rods under static, quasi-static action and seismic action (performance category C1+C2) |                            |                               |                      |  |                                 |      |      |      |      |                  |      |



**Table C3: Characteristic values of shear loads for threaded rods under static, quasi-static action and seismic action (performance category C1+C2)**

| Anchor size threaded rod  |                            | M 8  | M 10                            | M 12                  | M 16                            | M 20 | M24 | M 27             | M 30 |    |
|---|----------------------------|------|---------------------------------|-----------------------|---------------------------------|------|-----|------------------|------|----|
| <b>Steel failure without lever arm</b>  |                            |      |                                 |                       |                                 |      |     |                  |      |    |
| Characteristic shear resistance   | $V_{Rk,s}$                 | [kN] | see Table C1                    |                       |                                 |      |     |                  |      |    |
|   | $V_{Rk,s,C1}$              | [kN] | $0,70 \cdot V_{Rk,s}$           |                       |                                 |      |     |                  |      |    |
|   | $V_{Rk,s,C2}$              | [kN] | (NPD)                           | $0,80 \cdot V_{Rk,s}$ | No Performance Determined (NPD) |      |     |                  |      |    |
| Partial safety factor   | $\gamma_{Ms,V}$            | [-]  | see Table C1                    |                       |                                 |      |     |                  |      |    |
| <b>Steel failure with lever arm</b>   |                            |      |                                 |                       |                                 |      |     |                  |      |    |
| Characteristic bending moment   | $M^0_{Rk,s}$               | [Nm] | see Table C1                    |                       |                                 |      |     |                  |      |    |
|   | $M^0_{Rk,s,C1}$            | [Nm] | No Performance Determined (NPD) |                       |                                 |      |     |                  |      |    |
|   | $M^0_{Rk,s,C2}$            | [Nm] | No Performance Determined (NPD) |                       |                                 |      |     |                  |      |    |
| Partial safety factor   | $\gamma_{Ms,V}$            | [-]  | see Table C1                    |                       |                                 |      |     |                  |      |    |
| <b>Concrete pry-out failure</b>   |                            |      |                                 |                       |                                 |      |     |                  |      |    |
| Factor $k_3$ in equation (27) of CEN/TS 1992-4-5 Section 6.3.3<br>Factor $k$ in equation (5.7) of Technical Report TR 029                                       | $k_{(3)}$                  | [-]  | 2,0                             |                       |                                 |      |     |                  |      |    |
| Installation safety factor  | $\gamma_2 = \gamma_{inst}$ | [-]  | 1,0                             |                       |                                 |      |     |                  |      |    |
| <b>Concrete edge failure</b>  |                            |      |                                 |                       |                                 |      |     |                  |      |    |
| Effective length of anchor  | $l_f$                      | [mm] | $l_f = \min(h_{ef}; 8 d_{nom})$ |                       |                                 |      |     |                  |      |    |
| Outside diameter of anchor  | $d_{nom}$                  | [mm] | 8                               | 10                    | 12                              | 16   | 20  | 24               | 27   | 30 |
| Installation safety factor  | $\gamma_2 = \gamma_{inst}$ | [-]  | 1,0                             |                       |                                 |      |     |                  |      |    |
|   |                            |      |                                 |                       |                                 |      |     |                  |      |    |
| <b>B+BTec Injection System BIS-HY for concrete</b>  |                            |      |                                 |                       |                                 |      |     | <b>Annex C 3</b> |      |    |
| <b>Performances</b><br>Characteristic values of shear loads for threaded rods under static, quasi-static action and seismic action (performance category C1+C2) |                            |      |                                 |                       |                                 |      |     |                  |      |    |

**Table C4: Characteristic values of tension loads for internal threaded rods under static and quasi-static action**

| Anchor size internally threaded rods  |                            |                 | IG-M 6                  | IG-M 8   | IG-M 10 | IG-M 12 | IG-M 16          | IG-M 20 |     |
|---|----------------------------|-----------------|-------------------------|--|---------|---------|------------------|---------|-----|
| <b>Steel failure<sup>1)</sup></b>   |                            |                 |                         |  |         |         |                  |         |     |
| Characteristic tension resistance, Steel, strength class 5.8  | $N_{Rk,s}$                 | [kN]            | 10                      | 17   | 29      | 42      | 76               | 123     |     |
| Partial safety factor   | $\gamma_{Ms,N}$            | [-]             | 1,5                     |  |         |         |                  |         |     |
| Characteristic tension resistance, Steel, strength class 8.8  | $N_{Rk,s}$                 | [kN]            | 16                      | 27   | 46      | 67      | 121              | 196     |     |
| Partial safety factor   | $\gamma_{Ms,N}$            | [-]             | 1,5                     |  |         |         |                  |         |     |
| Characteristic tension resistance, Stainless Steel A4, Strength class 70  | $N_{Rk,s}$                 | [kN]            | 14                      | 26   | 41      | 59      | 110              | 172     |     |
| Partial safety factor   | $\gamma_{Ms,N}$            | [-]             | 1,87                    |  |         |         |                  |         |     |
| <b>Combined pull-out and concrete cone failure</b>  |                            |                 |                         |  |         |         |                  |         |     |
| Characteristic bond resistance in non-cracked concrete C20/25   |                            |                 |                         |  |         |         |                  |         |     |
| Temperature range I: 80°C/50°C  | dry and wet concrete       | $\tau_{Rk,ucr}$ | [N/mm <sup>2</sup> ]    | 17   | 16      | 15      | 14               | 13      | 13  |
| Temperature range II: 120°C/72°C  | dry and wet concrete       | $\tau_{Rk,ucr}$ | [N/mm <sup>2</sup> ]    | 14   | 14      | 13      | 12               | 12      | 11  |
| Temperature range III: 160°C/100°C  | dry and wet concrete       | $\tau_{Rk,ucr}$ | [N/mm <sup>2</sup> ]    | 12   | 11      | 10      | 9,5              | 9,0     | 9,0 |
| Characteristic bond resistance in cracked concrete C20/25   |                            |                 |                         |  |         |         |                  |         |     |
| Temperature range I: 80°C/50°C  | dry and wet concrete       | $\tau_{Rk,cr}$  | [N/mm <sup>2</sup> ]    | 7,0  | 7,5     | 8,5     | 8,5              | 8,5     | 8,5 |
| Temperature range II: 120°C/72°C  | dry and wet concrete       | $\tau_{Rk,cr}$  | [N/mm <sup>2</sup> ]    | 6,0  | 6,5     | 7,5     | 7,5              | 7,5     | 7,5 |
| Temperature range III: 160°C/100°C  | dry and wet concrete       | $\tau_{Rk,cr}$  | [N/mm <sup>2</sup> ]    | 5,5  | 6,0     | 6,5     | 6,5              | 6,5     | 6,5 |
| Increasing factors for concrete $\psi_c$  | C25/30                     |                 |                         | 1,02   |         |         |                  |         |     |
|   | C30/37                     |                 |                         | 1,04   |         |         |                  |         |     |
|   | C35/45                     |                 |                         | 1,07   |         |         |                  |         |     |
|   | C40/50                     |                 |                         | 1,08   |         |         |                  |         |     |
|   | C45/55                     |                 |                         | 1,09   |         |         |                  |         |     |
|   | C50/60                     |                 |                         | 1,10   |         |         |                  |         |     |
| Factor according to CEN/TS 1992-4-5 Section 6.2.2.3   | Non-cracked concrete       | $k_B$           | [-]                     | 10,1   |         |         |                  |         |     |
|   | Cracked concrete           |                 |                         | 7,2  |         |         |                  |         |     |
| <b>Concrete cone failure</b>  |                            |                 |                         |  |         |         |                  |         |     |
| Factor according to CEN/TS 1992-4-5 Section 6.2.3.1   | Non-cracked concrete       | $k_{ucr}$       | [-]                     | 10,1   |         |         |                  |         |     |
|   | Cracked concrete           | $k_{cr}$        | [-]                     | 7,2  |         |         |                  |         |     |
| Edge distance   | $c_{cr,N}$                 |                 | [mm]                    | 1,5 $h_{ef}$   |         |         |                  |         |     |
| Axial distance  | $s_{cr,N}$                 |                 | [mm]                    | 3,0 $h_{ef}$   |         |         |                  |         |     |
| <b>Splitting failure</b>  |                            |                 |                         |  |         |         |                  |         |     |
| Edge distance   | $h/h_{ef} \geq 2,0$        | $c_{cr,sp}$     | [mm]                    | 1,0 $h_{ef}$   |         |         |                  |         |     |
|   | $2,0 > h/h_{ef} > 1,3$     |                 |                         | $2 \cdot h_{ef} \left( 2,5 - \frac{h}{h_{ef}} \right)$ |         |         |                  |         |     |
|   | $h/h_{ef} \leq 1,3$        |                 |                         | 2,4 $h_{ef}$   |         |         |                  |         |     |
| Axial distance  | $s_{cr,sp}$                |                 | [mm]                    | 2 $c_{cr,sp}$  |         |         |                  |         |     |
| Installation safety factor (CAC) (dry and wet concrete)   | $\gamma_2 = \gamma_{inst}$ | [-]             | 1,0 (1,2) <sup>2)</sup> |  |         |         | 1,2              |         |     |
| Installation safety factor (MAC) (dry and wet concrete)   | $\gamma_2 = \gamma_{inst}$ | [-]             | 1,2                     |  |         |         | -                |         |     |
| <sup>1)</sup> Fastening screws or threaded rods (incl. nut and washer) must comply with the appropriate material and property class of the internal threaded rod. The characteristic tension resistance for steel failure of the given strength class are valid for the internal threaded rod and the fastening element.<br><sup>2)</sup> Value in brackets for cracked concrete. |                            |                 |                         |  |         |         |                  |         |     |
| <b>B+BTec Injection System BIS-HY for concrete</b>  |                            |                 |                         |  |         |         | <b>Annex C 4</b> |         |     |
| <b>Performances</b><br>Characteristic values of tension loads for internal threaded rods under static and quasi-static action   |                            |                 |                         |  |         |         |                  |         |     |

**Table C5: Characteristic values of shear loads for internal threaded rods under static and quasi-static action**

| Anchor size for internally threaded rods   |                            |      | IG-M 6                          | IG-M 8 | IG-M 10 | IG-M 12 | IG-M 16          | IG-M 20 |
|--|----------------------------|------|---------------------------------|--------|---------|---------|------------------|---------|
| <b>Steel failure without lever arm<sup>1)</sup></b>  |                            |      |                                 |        |         |         |                  |         |
| Characteristic shear resistance, Steel, strength class 5.8   | $V_{Rk,s}$                 | [kN] | 5                               | 9      | 15      | 21      | 38               | 61      |
| Partial safety factor  | $\gamma_{Ms,V}$            | [-]  | 1,25                            |        |         |         |                  |         |
| Characteristic shear resistance, Steel, strength class 8.8   | $V_{Rk,s}$                 | [kN] | 8                               | 14     | 23      | 34      | 60               | 98      |
| Partial safety factor  | $\gamma_{Ms,V}$            | [-]  | 1,25                            |        |         |         |                  |         |
| Characteristic shear resistance, Stainless Steel A4, Strength class 70   | $V_{Rk,s}$                 | [kN] | 7                               | 13     | 20      | 30      | 55               | 86      |
| Partial safety factor  | $\gamma_{Ms,V}$            | [-]  | 1,56                            |        |         |         |                  |         |
| <b>Steel failure with lever arm<sup>1)</sup></b>   |                            |      |                                 |        |         |         |                  |         |
| Characteristic bending moment, Steel, strength class 5.8   | $M_{Rk,s}^0$               | [Nm] | 8                               | 19     | 37      | 66      | 167              | 325     |
| Partial safety factor  | $\gamma_{Ms,V}$            | [-]  | 1,25                            |        |         |         |                  |         |
| Characteristic bending moment, Steel, strength class 8.8   | $M_{Rk,s}^0$               | [Nm] | 12                              | 30     | 60      | 105     | 267              | 519     |
| Partial safety factor  | $\gamma_{Ms,V}$            | [-]  | 1,25                            |        |         |         |                  |         |
| Characteristic bending moment, Stainless Steel A4, Strength class 70   | $M_{Rk,s}^0$               | [Nm] | 11                              | 26     | 52      | 92      | 233              | 454     |
| Partial safety factor  | $\gamma_{Ms,V}$            | [-]  | 1,56                            |        |         |         |                  |         |
| <b>Concrete pry-out failure</b>  |                            |      |                                 |        |         |         |                  |         |
| Factor $k_3$ in equation (27) of CEN/TS 1992-4-5 Section 6.3.3<br>Factor $k$ in equation (5.7) of Technical Report TR 029  | $k_{(3)}$                  | [-]  | 2,0                             |        |         |         |                  |         |
| Installation safety factor   | $\gamma_2 = \gamma_{inst}$ | [-]  | 1,0                             |        |         |         |                  |         |
| <b>Concrete edge failure</b>   |                            |      |                                 |        |         |         |                  |         |
| Effective length of anchor   | $l_f$                      | [mm] | $l_f = \min(h_{ef}; 8 d_{nom})$ |        |         |         |                  |         |
| Outside diameter of anchor   | $d_{nom}$                  | [mm] | 10                              | 12     | 16      | 20      | 24               | 30      |
| Installation safety factor   | $\gamma_2 = \gamma_{inst}$ | [-]  | 1,0                             |        |         |         |                  |         |
| <sup>1)</sup> Fastening screws or threaded rods (incl. nut and washer) must comply with the appropriate material and property class of the internal threaded rod. The characteristic tension resistance for steel failure of the given strength class are valid for the internal threaded rod and the fastening element. |                            |      |                                 |        |         |         |                  |         |
| <b>B+BTec Injection System BIS-HY for concrete</b>   |                            |      |                                 |        |         |         | <b>Annex C 5</b> |         |
| <b>Performances</b><br>Characteristic values of shear loads for internal threaded rods under static and quasi-static action  |                            |      |                                 |        |         |         |                  |         |

**Table C6: Characteristic values of tension loads for rebar under static, quasi-static action and seismic action (performance category C1)**

| Anchor size reinforcing bar  |                            |                               |                         | Ø 8  | Ø 10 | Ø 12 | Ø 14 | Ø 16 | Ø 20 | Ø 25 | Ø 28             | Ø 32 |
|--|----------------------------|-------------------------------|-------------------------|--|------|------|------|------|------|------|------------------|------|
| <b>Steel failure</b>   |                            |                               |                         |  |      |      |      |      |      |      |                  |      |
| Characteristic tension resistance  | $N_{Rk,s} = N_{Rk,s,C1}$   | [kN]                          | $A_s \cdot f_{uk}^{2)}$ |  |      |      |      |      |      |      |                  |      |
| Cross section area   | $A_s$                      | [mm <sup>2</sup> ]            | 50                      | 79   | 113  | 154  | 201  | 214  | 491  | 616  | 804              |      |
| Partial safety factor  | $\gamma_{Ms,N}$            | [-]                           | 1,4 <sup>3)</sup>       |  |      |      |      |      |      |      |                  |      |
| <b>Combined pull-out and concrete cone failure</b>   |                            |                               |                         |  |      |      |      |      |      |      |                  |      |
| Characteristic bond resistance in non-cracked concrete C20/25  |                            |                               |                         |  |      |      |      |      |      |      |                  |      |
| Temperature range I:<br>80°C/50°C  | dry and wet concrete       | $\tau_{Rk,ucr}$               | [N/mm <sup>2</sup> ]    | 14   | 14   | 14   | 14   | 13   | 13   | 13   | 13               | 13   |
| Temperature range II:<br>120°C/72°C  | dry and wet concrete       | $\tau_{Rk,ucr}$               | [N/mm <sup>2</sup> ]    | 13   | 12   | 12   | 12   | 12   | 11   | 11   | 11               | 11   |
| Temperature range III:<br>160°C/100°C  | dry and wet concrete       | $\tau_{Rk,ucr}$               | [N/mm <sup>2</sup> ]    | 10   | 10   | 9,5  | 9,5  | 9,5  | 9,0  | 9,0  | 9,0              | 9,0  |
| Characteristic bond resistance in cracked concrete C20/25  |                            |                               |                         |  |      |      |      |      |      |      |                  |      |
| Temperature range I:<br>80°C/50°C  | dry and wet concrete       | $\tau_{Rk,cr} = \tau_{Rk,C1}$ | [N/mm <sup>2</sup> ]    | 5,0  | 5,5  | 6,0  | 6,0  | 7,5  | 7,5  | 7,5  | 7,5              | 8,0  |
| Temperature range II:<br>120°C/72°C  | dry and wet concrete       | $\tau_{Rk,cr} = \tau_{Rk,C1}$ | [N/mm <sup>2</sup> ]    | 4,5  | 5,0  | 5,0  | 5,5  | 6,5  | 6,5  | 6,5  | 6,5              | 7,0  |
| Temperature range III:<br>160°C/100°C  | dry and wet concrete       | $\tau_{Rk,cr} = \tau_{Rk,C1}$ | [N/mm <sup>2</sup> ]    | 4,0  | 4,5  | 4,5  | 5,0  | 5,5  | 6,0  | 6,0  | 5,5              | 6,5  |
| Increasing factors for concrete<br>$\psi_c$  | C25/30                     |                               |                         | 1,02   |      |      |      |      |      |      |                  |      |
|  | C30/37                     |                               |                         | 1,04   |      |      |      |      |      |      |                  |      |
|  | C35/45                     |                               |                         | 1,07   |      |      |      |      |      |      |                  |      |
|  | C40/50                     |                               |                         | 1,08   |      |      |      |      |      |      |                  |      |
|  | C45/55                     |                               |                         | 1,09   |      |      |      |      |      |      |                  |      |
|  | C50/60                     |                               |                         | 1,10   |      |      |      |      |      |      |                  |      |
| Factor according to<br>CEN/TS 1992-4-5<br>Section 6.2.2.3  | Non-cracked concrete       | $k_8$                         | [-]                     | 10,1   |      |      |      |      |      |      |                  |      |
|  | Cracked concrete           |                               |                         | 7,2  |      |      |      |      |      |      |                  |      |
| <b>Concrete cone failure</b>   |                            |                               |                         |  |      |      |      |      |      |      |                  |      |
| Factor according to<br>CEN/TS 1992-4-5<br>Section 6.2.3.1  | Non-cracked concrete       | $k_{ucr}$                     | [-]                     | 10,1   |      |      |      |      |      |      |                  |      |
|  | Cracked concrete           | $k_{cr}$                      | [-]                     | 7,2  |      |      |      |      |      |      |                  |      |
| Edge distance  | $c_{cr,N}$                 |                               | [mm]                    | 1,5 $h_{ef}$   |      |      |      |      |      |      |                  |      |
| Axial distance   | $s_{cr,N}$                 |                               | [mm]                    | 3,0 $h_{ef}$   |      |      |      |      |      |      |                  |      |
| <b>Splitting failure</b>   |                            |                               |                         |  |      |      |      |      |      |      |                  |      |
| Edge distance  | $h/h_{ef} \geq 2,0$        | $c_{cr,sp}$                   | [mm]                    | 1,0 $h_{ef}$   |      |      |      |      |      |      |                  |      |
|  | $2,0 > h/h_{ef} > 1,3$     |                               |                         | $2 \cdot h_{ef} \left( 2,5 - \frac{h}{h_{ef}} \right)$ |      |      |      |      |      |      |                  |      |
|  | $h/h_{ef} \leq 1,3$        |                               |                         | 2,4 $h_{ef}$   |      |      |      |      |      |      |                  |      |
| Axial distance   | $s_{cr,sp}$                |                               | [mm]                    | 2 $c_{cr,sp}$  |      |      |      |      |      |      |                  |      |
| Installation safety factor (CAC)<br>(dry and wet concrete)   | $\gamma_2 = \gamma_{inst}$ |                               | [-]                     | 1,0 (1,2) <sup>1)</sup>                                |      |      |      |      | 1,2  |      |                  |      |
| Installation safety factor (MAC)<br>(dry and wet concrete)   | $\gamma_2 = \gamma_{inst}$ |                               | [-]                     | 1,2  |      |      |      |      | -    |      |                  |      |
| <sup>1)</sup> Value in brackets for cracked concrete<br><sup>2)</sup> $f_{uk}$ shall be taken from the specifications of reinforcing bars<br><sup>3)</sup> in absence of national regulation |                            |                               |                         |  |      |      |      |      |      |      |                  |      |
| <b>B+BTec Injection System BIS-HY for concrete</b>   |                            |                               |                         |  |      |      |      |      |      |      | <b>Annex C 6</b> |      |
| <b>Performances</b><br>Characteristic values of tension loads for rebar under static, quasi-static action and seismic action (performance category C1)                                       |                            |                               |                         |  |      |      |      |      |      |      |                  |      |

**Table C7: Characteristic values of shear loads for rebar under static, quasi-static action and seismic action (performance category C1)**

| Anchor size reinforcing bar  |                            | Ø 8                | Ø 10                               | Ø 12 | Ø 14 | Ø 16 | Ø 20 | Ø 25 | Ø 28             | Ø 32 |      |
|--|----------------------------|--------------------|------------------------------------|------|------|------|------|------|------------------|------|------|
| <b>Steel failure without lever arm</b>   |                            |                    |                                    |      |      |      |      |      |                  |      |      |
| Characteristic shear resistance  | $V_{Rk,s}$                 | [kN]               | $0,50 \cdot N_{Rk,s}$              |      |      |      |      |      |                  |      |      |
|  | $V_{Rk,s,C1}$              | [kN]               | $0,37 \cdot N_{Rk,s}$              |      |      |      |      |      |                  |      |      |
| Partial safety factor  | $\gamma_{Ms,V}$            | [-]                | $1,5^2)$                           |      |      |      |      |      |                  |      |      |
| Ductility factor according to CEN/TS 1992-4-5 Section 6.3.2.1  | $k_2$                      |                    | 0,8                                |      |      |      |      |      |                  |      |      |
| <b>Steel failure with lever arm</b>  |                            |                    |                                    |      |      |      |      |      |                  |      |      |
| Characteristic bending moment  | $M^0_{Rk,s}$               | [Nm]               | $1,2 \cdot W_{el} \cdot f_{uk}^1)$ |      |      |      |      |      |                  |      |      |
|  | $M^0_{Rk,s,C1}$            | [Nm]               | No Performance Determined (NPD)    |      |      |      |      |      |                  |      |      |
| Elastic section modulus  | $W_{el}$                   | [mm <sup>3</sup> ] | 50                                 | 98   | 170  | 269  | 402  | 785  | 1534             | 2155 | 3217 |
| Partial safety factor  | $\gamma_{Ms,V}$            | [-]                | $1,5^2)$                           |      |      |      |      |      |                  |      |      |
| <b>Concrete pry-out failure</b>  |                            |                    |                                    |      |      |      |      |      |                  |      |      |
| Factor $k_3$ in equation (27) of CEN/TS 1992-4-5 Section 6.3.3<br>Factor $k$ in equation (5.7) of Technical Report TR 029                            | $k_{(3)}$                  | [-]                | 2,0                                |      |      |      |      |      |                  |      |      |
| Installation safety factor   | $\gamma_2 = \gamma_{Inst}$ | [-]                | 1,0                                |      |      |      |      |      |                  |      |      |
| <b>Concrete edge failure</b>   |                            |                    |                                    |      |      |      |      |      |                  |      |      |
| Effective length of anchor   | $l_f$                      | [mm]               | $l_f = \min(h_{ef}; 8 d_{nom})$    |      |      |      |      |      |                  |      |      |
| Outside diameter of anchor   | $d_{nom}$                  | [mm]               | 8                                  | 10   | 12   | 14   | 16   | 20   | 25               | 28   | 32   |
| Installation safety factor   | $\gamma_2 = \gamma_{Inst}$ | [-]                | 1,0                                |      |      |      |      |      |                  |      |      |
| <sup>1)</sup> $f_{uk}$ shall be taken from the specifications of reinforcing bars<br><sup>2)</sup> in absence of national regulation                 |                            |                    |                                    |      |      |      |      |      |                  |      |      |
| <b>B+BTec Injection System BIS-HY for concrete</b>   |                            |                    |                                    |      |      |      |      |      | <b>Annex C 7</b> |      |      |
| <b>Performances</b><br>Characteristic values of shear loads for rebar under static, quasi-static action and seismic action (performance category C1) |                            |                    |                                    |      |      |      |      |      |                  |      |      |

**Table C8: Displacements under tension load<sup>1)</sup> (threaded rod)**

| Anchor size threaded rod  |                            |                           | M 8   | M 10  | M 12  | M 16                          | M 20  | M24   | M 27  | M 30  |
|---|----------------------------|---------------------------|-------|-------|-------|-------------------------------|-------|-------|-------|-------|
| <b>Non-cracked concrete C20/25 under static and quasi-static action</b>         |                            |                           |       |       |       |                               |       |       |       |       |
| Temperature range I:<br>80°C/50°C   | $\delta_{N0}$ -factor      | [mm/(N/mm <sup>2</sup> )] | 0,031 | 0,032 | 0,034 | 0,037                         | 0,039 | 0,042 | 0,044 | 0,046 |
|   | $\delta_{N\infty}$ -factor | [mm/(N/mm <sup>2</sup> )] | 0,040 | 0,042 | 0,044 | 0,047                         | 0,051 | 0,054 | 0,057 | 0,060 |
| Temperature range II:<br>120°C/72°C   | $\delta_{N0}$ -factor      | [mm/(N/mm <sup>2</sup> )] | 0,032 | 0,034 | 0,035 | 0,038                         | 0,041 | 0,044 | 0,046 | 0,048 |
|   | $\delta_{N\infty}$ -factor | [mm/(N/mm <sup>2</sup> )] | 0,042 | 0,044 | 0,045 | 0,049                         | 0,053 | 0,056 | 0,059 | 0,062 |
| Temperature range III:<br>160°C/100°C   | $\delta_{N0}$ -factor      | [mm/(N/mm <sup>2</sup> )] | 0,121 | 0,126 | 0,131 | 0,142                         | 0,153 | 0,163 | 0,171 | 0,179 |
|   | $\delta_{N\infty}$ -factor | [mm/(N/mm <sup>2</sup> )] | 0,124 | 0,129 | 0,135 | 0,146                         | 0,157 | 0,168 | 0,176 | 0,184 |
| <b>Cracked concrete C20/25 under static, quasi-static and seismic C1 action</b> |                            |                           |       |       |       |                               |       |       |       |       |
| Temperature range I:<br>80°C/50°C   | $\delta_{N0}$ -factor      | [mm/(N/mm <sup>2</sup> )] | 0,081 | 0,083 | 0,085 | 0,090                         | 0,095 | 0,099 | 0,103 | 0,106 |
|   | $\delta_{N\infty}$ -factor | [mm/(N/mm <sup>2</sup> )] | 0,104 | 0,107 | 0,110 | 0,116                         | 0,122 | 0,128 | 0,133 | 0,137 |
| Temperature range II:<br>120°C/72°C   | $\delta_{N0}$ -factor      | [mm/(N/mm <sup>2</sup> )] | 0,084 | 0,086 | 0,088 | 0,093                         | 0,098 | 0,103 | 0,107 | 0,110 |
|   | $\delta_{N\infty}$ -factor | [mm/(N/mm <sup>2</sup> )] | 0,108 | 0,111 | 0,114 | 0,121                         | 0,127 | 0,133 | 0,138 | 0,143 |
| Temperature range III:<br>160°C/100°C   | $\delta_{N0}$ -factor      | [mm/(N/mm <sup>2</sup> )] | 0,312 | 0,321 | 0,330 | 0,349                         | 0,367 | 0,385 | 0,399 | 0,412 |
|   | $\delta_{N\infty}$ -factor | [mm/(N/mm <sup>2</sup> )] | 0,321 | 0,330 | 0,340 | 0,358                         | 0,377 | 0,396 | 0,410 | 0,424 |
| <b>Cracked concrete C20/25 under seismic C2 action</b>                          |                            |                           |       |       |       |                               |       |       |       |       |
| All temperature ranges  | $\delta_{N,seis(DLS)}$     | [mm/(N/mm <sup>2</sup> )] | (NPD) | 0,120 |       | No Parameter Determined (NPD) |       |       |       |       |
|   | $\delta_{N,seis(ULS)}$     | [mm/(N/mm <sup>2</sup> )] |       | 0,140 |       |                               |       |       |       |       |

<sup>1)</sup> Calculation of the displacement

$$\delta_{N0} = \delta_{N0}\text{-factor} \cdot \tau; \quad \tau: \text{action bond stress for tension}$$

$$\delta_{N\infty} = \delta_{N\infty}\text{-factor} \cdot \tau;$$

**Table C9: Displacements under shear load<sup>1)</sup> (threaded rod)**

| Anchor size threaded rod  |                            |           | M 8                           | M 10 | M 12 | M 16                          | M 20 | M24  | M 27 | M 30 |
|---|----------------------------|-----------|-------------------------------|------|------|-------------------------------|------|------|------|------|
| <b>Non-cracked and cracked concrete C20/25 under static, quasi-static and seismic C1 action</b> |                            |           |                               |      |      |                               |      |      |      |      |
| All temperature ranges  | $\delta_{V0}$ -factor      | [mm/(kN)] | 0,06                          | 0,06 | 0,05 | 0,04                          | 0,04 | 0,03 | 0,03 | 0,03 |
|   | $\delta_{V\infty}$ -factor | [mm/(kN)] | 0,09                          | 0,08 | 0,08 | 0,06                          | 0,06 | 0,05 | 0,05 | 0,05 |
| <b>Cracked concrete C20/25 under seismic C2 action</b>  |                            |           |                               |      |      |                               |      |      |      |      |
| All temperature ranges  | $\delta_{V,seis(DLS)}$     | [mm/(kN)] | No Parameter Determined (NPD) | 0,27 |      | No Parameter Determined (NPD) |      |      |      |      |
|   | $\delta_{V,seis(ULS)}$     | [mm/(kN)] |                               | 0,27 |      |                               |      |      |      |      |

<sup>1)</sup> Calculation of the displacement

$$\delta_{V0} = \delta_{V0}\text{-factor} \cdot V; \quad V: \text{action shear load}$$

$$\delta_{V\infty} = \delta_{V\infty}\text{-factor} \cdot V;$$

**B+BTec Injection System BIS-HY for concrete**

**Performances**  
Displacements (threaded rods)

**Annex C 8**



| <b>Table C10: Displacements under tension load<sup>1)</sup> (rebar)</b>   |                         |                           |       |       |       |       |       |       |       |                  |       |
|---|-------------------------|---------------------------|-------|-------|-------|-------|-------|-------|-------|------------------|-------|
| <b>Anchor size reinforcing bar</b>  |                         |                           | Ø 8   | Ø 10  | Ø 12  | Ø 14  | Ø 16  | Ø 20  | Ø 25  | Ø 28             | Ø 32  |
| <b>Non-cracked concrete C20/25 under static and quasi-static action</b>   |                         |                           |       |       |       |       |       |       |       |                  |       |
| Temperature range I:<br>80°C/50°C   | δ <sub>N0</sub> -factor | [mm/(N/mm <sup>2</sup> )] | 0,031 | 0,032 | 0,034 | 0,035 | 0,037 | 0,039 | 0,043 | 0,045            | 0,048 |
|   | δ <sub>N∞</sub> -factor | [mm/(N/mm <sup>2</sup> )] | 0,040 | 0,042 | 0,044 | 0,045 | 0,047 | 0,051 | 0,055 | 0,058            | 0,063 |
| Temperature range II:<br>120°C/72°C   | δ <sub>N0</sub> -factor | [mm/(N/mm <sup>2</sup> )] | 0,032 | 0,034 | 0,035 | 0,036 | 0,038 | 0,041 | 0,045 | 0,047            | 0,050 |
|   | δ <sub>N∞</sub> -factor | [mm/(N/mm <sup>2</sup> )] | 0,042 | 0,044 | 0,045 | 0,047 | 0,049 | 0,053 | 0,057 | 0,060            | 0,065 |
| Temperature range III:<br>160°C/100°C   | δ <sub>N0</sub> -factor | [mm/(N/mm <sup>2</sup> )] | 0,121 | 0,126 | 0,131 | 0,137 | 0,142 | 0,153 | 0,164 | 0,172            | 0,186 |
|   | δ <sub>N∞</sub> -factor | [mm/(N/mm <sup>2</sup> )] | 0,124 | 0,129 | 0,135 | 0,141 | 0,146 | 0,157 | 0,169 | 0,177            | 0,192 |
| <b>Cracked concrete C20/25 under static, quasi-static and seismic C1 action</b>   |                         |                           |       |       |       |       |       |       |       |                  |       |
| Temperature range I:<br>80°C/50°C   | δ <sub>N0</sub> -factor | [mm/(N/mm <sup>2</sup> )] | 0,081 | 0,083 | 0,085 | 0,087 | 0,090 | 0,095 | 0,099 | 0,103            | 0,108 |
|   | δ <sub>N∞</sub> -factor | [mm/(N/mm <sup>2</sup> )] | 0,104 | 0,107 | 0,110 | 0,113 | 0,116 | 0,122 | 0,128 | 0,133            | 0,141 |
| Temperature range II:<br>120°C/72°C   | δ <sub>N0</sub> -factor | [mm/(N/mm <sup>2</sup> )] | 0,084 | 0,086 | 0,088 | 0,090 | 0,093 | 0,098 | 0,103 | 0,107            | 0,113 |
|   | δ <sub>N∞</sub> -factor | [mm/(N/mm <sup>2</sup> )] | 0,108 | 0,111 | 0,114 | 0,118 | 0,121 | 0,127 | 0,133 | 0,138            | 0,148 |
| Temperature range III:<br>160°C/100°C   | δ <sub>N0</sub> -factor | [mm/(N/mm <sup>2</sup> )] | 0,312 | 0,321 | 0,330 | 0,340 | 0,349 | 0,367 | 0,385 | 0,399            | 0,425 |
|   | δ <sub>N∞</sub> -factor | [mm/(N/mm <sup>2</sup> )] | 0,321 | 0,330 | 0,340 | 0,349 | 0,358 | 0,377 | 0,396 | 0,410            | 0,449 |
| <sup>1)</sup> Calculation of the displacement<br>$\delta_{N0} = \delta_{N0}\text{-factor} \cdot \tau$ ; $\tau$ : action bond stress for tension<br>$\delta_{N\infty} = \delta_{N\infty}\text{-factor} \cdot \tau$ ; |                         |                           |       |       |       |       |       |       |       |                  |       |
| <b>Table C11: Displacement under shear load<sup>1)</sup> (rebar)</b>  |                         |                           |       |       |       |       |       |       |       |                  |       |
| <b>Anchor size reinforcing bar</b>  |                         |                           | Ø 8   | Ø 10  | Ø 12  | Ø 14  | Ø 16  | Ø 20  | Ø 25  | Ø 28             | Ø 32  |
| <b>For concrete C20/25 under static, quasi-static and seismic C1 action</b>   |                         |                           |       |       |       |       |       |       |       |                  |       |
| All temperature ranges  | δ <sub>V0</sub> -factor | [mm/(kN)]                 | 0,06  | 0,05  | 0,05  | 0,04  | 0,04  | 0,04  | 0,03  | 0,03             | 0,03  |
|   | δ <sub>V∞</sub> -factor | [mm/(kN)]                 | 0,09  | 0,08  | 0,08  | 0,06  | 0,06  | 0,05  | 0,05  | 0,04             | 0,04  |
| <sup>1)</sup> Calculation of the displacement<br>$\delta_{V0} = \delta_{V0}\text{-factor} \cdot V$ ; $V$ : action shear load<br>$\delta_{V\infty} = \delta_{V\infty}\text{-factor} \cdot V$ ;                       |                         |                           |       |       |       |       |       |       |       |                  |       |
| <b>B+BTec Injection System BIS-HY for concrete</b>  |                         |                           |       |       |       |       |       |       |       | <b>Annex C 9</b> |       |
| <b>Performances</b><br>Displacements (rebar)  |                         |                           |       |       |       |       |       |       |       |                  |       |

