

Approval body for construction products
and types of construction

Bautechnisches Prüfamt

An institution established by the Federal and
Laender Governments



European Technical Assessment

ETA-17/0333
of 10 October 2017

English translation prepared by DIBt - Original version in German language

General Part

Technical Assessment Body issuing the
European Technical Assessment:

Deutsches Institut für Bautechnik

Trade name of the construction product

Staples Type A-154, B-180 and C-203 in galvanised and
stainless steel

Product family
to which the construction product belongs

Dowel-type fasteners with resin coating

Manufacturer

BAUSSMANN
Collated Fasteners
Industriestraße 45
57413 Finnentrop
DEUTSCHLAND

Manufacturing plant

Werk 2:
Therecker Weg 3, 57413 Finnentrop, Deutschland

Werk 3:
Industriestraße 38, 57413 Finnentrop, Deutschland

This European Technical Assessment
contains

14 pages including 3 annexes which form an integral part
of this assessment

This European Technical Assessment is
issued in accordance with Regulation (EU)
No 305/2011, on the basis of

EAD 130019-00-0603

The European Technical Assessment is issued by the Technical Assessment Body in its official language. Translations of this European Technical Assessment in other languages shall fully correspond to the original issued document and shall be identified as such.

Communication of this European Technical Assessment, including transmission by electronic means, shall be in full. However, partial reproduction may only be made with the written consent of the issuing Technical Assessment Body. Any partial reproduction shall be identified as such.

This European Technical Assessment may be withdrawn by the issuing Technical Assessment Body, in particular pursuant to information by the Commission in accordance with Article 25(3) of Regulation (EU) No 305/2011.

Specific Part

1 Technical description of the product

Staples Type A-154, B-180 and C-203 are dowel type fasteners for timber constructions made of non-alloy steel rods according to EN ISO 16120 or made of stainless steel C 20 drawn from austenitic steel rods in accordance with EN 10088-1. The staples have a special resin coating with a minimum length of 50 % of the legs.

The diameters of the staple legs are for Type A-154 $d=1,54 \text{ mm} \pm 0,03 \text{ mm}$, Type B-180 $d=1,80 \text{ mm} \pm 0,03 \text{ mm}$ or Type C-203 $d=2,03 \text{ mm} \pm 0,03 \text{ mm}$. Further dimensions are shown in Annex 1.

2 Specification of the intended use in accordance with the applicable European Assessment Document

The performances given in Section 3 are only valid if the Staples Type A-154, B-180 and C-203 are used in compliance with the specifications and conditions given in Annex 1 to 3.

The verifications and assessment methods on which this European Technical Assessment is based lead to the assumption of a working life of staples of at least 50 years. The indications given on the working life cannot be interpreted as a guarantee given by the producer, but are to be regarded only as a means for choosing the right products in relation to the expected economically reasonable working life of the works.

3 Performance of the product and references to the methods used for its assessment

3.1 Mechanical resistance and stability (BWR 1)

Essential characteristic	Performance
Dimensions	See Annex 1
Characteristic yield moment	See Annex 3
Withdrawal capacity for short-term and medium-term loads	See Annex 3
Withdrawal capacity for long term and permanent loads	See Annex 3
Characteristic head pull-through parameter	See Annex 3
Minimum tensile strength of the wire	See Annex 3
Minimum and maximum thickness of the connected material	See Annex 3
Durability against corrosion	See Annex 2
Durability of the resin coating	See Annex 2

3.2 Safety in case of fire (BWR 2)

Essential characteristic	Performance
Reaction to fire	The staples are made of steel classified as Euroclass A1 in accordance with EC decision 96/603/EC, as amended by EC decision 2000/605/EC.

Due to the fact that a resin coating on the staples for use in timber constructions is very thin, it may be assumed that it does not make any contribution to fire growth or the fully developed fire and has no influence to the smoke hazard.

3.3 Safety and accessibility in use (BWR 4)

The essential characteristics of BWR 4 have been covered by BWR 1.

4 Assessment and verification of constancy of performance (AVCP) system applied, with reference to its legal base

In accordance with EAD No.130019-00-0603, the applicable European legal act is: [1997/176/EC(EU)].

The system to be applied is: 3

5 Technical details necessary for the implementation of the AVCP system, as provided for in the applicable EAD

Technical details necessary for the implementation of the AVCP system are laid down in the control plan deposited with Deutsches Institut für Bautechnik.

Issued in Berlin on 10 Oktober 2017 by Deutsches Institut für Bautechnik

Dr.-Ing. Lars Eckfeldt
p. p. Head of Department

beglaubigt:
Baumann

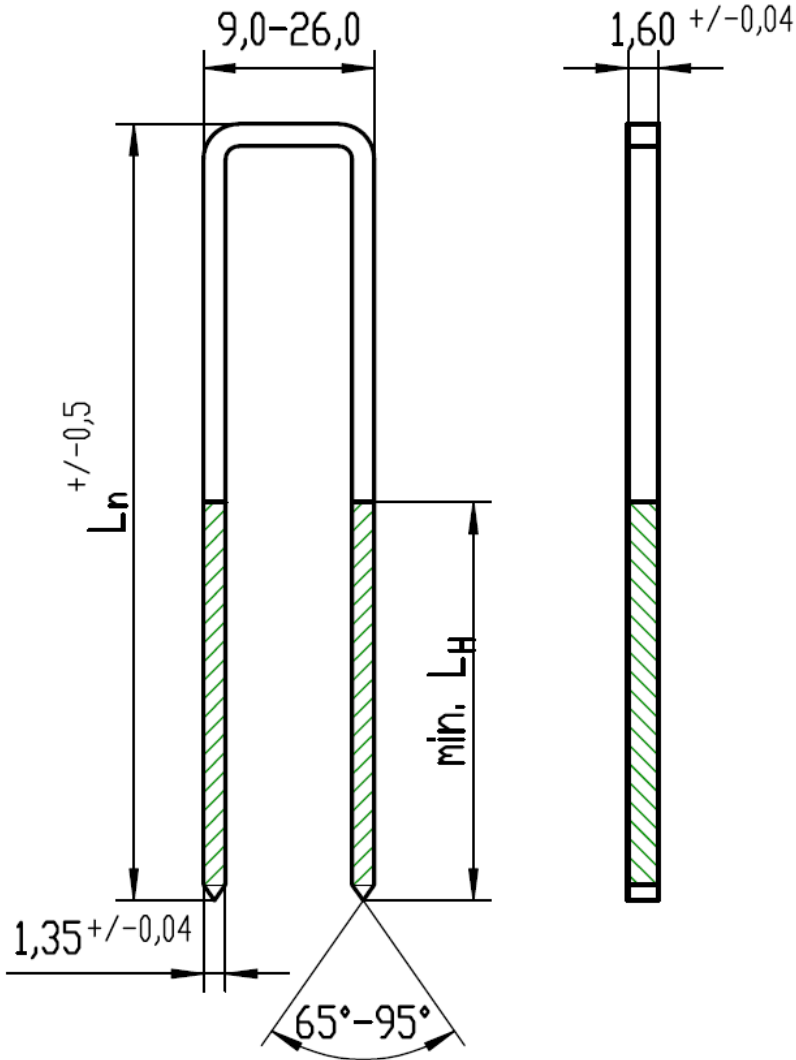

Klammerrohdraht:
Verzinkter runder Stahldraht C20
 $\text{Ø } 1,54 \pm 0,03 \text{ mm}$
 $R_m \text{ min. } 900 \text{ N/mm}^2$
 $A_{100} \text{ min. } 3\%$
 $\text{Ø}_n 1,54 \begin{smallmatrix} + \\ -0,03^A \end{smallmatrix} \text{ mm}$
 Zinkauflage min. $12\mu\text{m}$

Lack, Kleber

- Baussmann Typ 1
- Baussmann Typ 2

Schaftlänge L_n [mm]	28,0 bis 100,0
Harzung L_H [mm]	mind. $0,5 L_n$ $\geq 20 \text{ mm}$

Staples Type A-154, B-180 and C-203 in galvanised and stainless steel

Technical description of the product

Staples Type A-154 galvanised

Annex 1.1

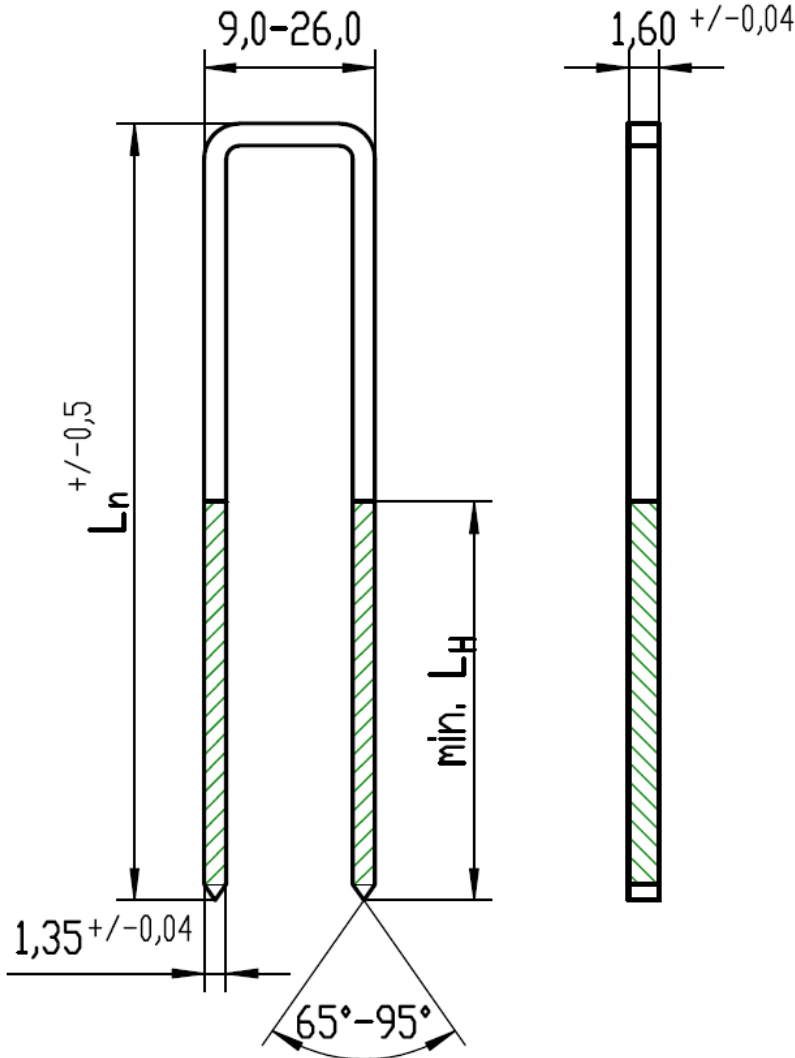

Klammerrohdraht:
Rostfreier runder Edelstahlraht
W.Nr. 1.4301 (AISI 304),
1.4401 (AISI 316); 1.4529
Ø 1,54 +/- 0,03 mm
Rm min. 900 N/mm²
A₁₀₀ min. 5%
Ø_n 1,54 ⁺/_{-0,03} mm

Lack, Kleber

- Bausmann Harz Typ 1
- Bausmann Harz Typ 2

Schaftlänge L _n [mm]	28,0 bis 100,0
Harzung L _H [mm]	mind. 0,5 L _n >= 20 mm

Staples Type A-154, B-180 and C-203 in galvanised and stainless steel	Annex 1.2
Technical description of the product	
Staples Type A-154 stainless steel	

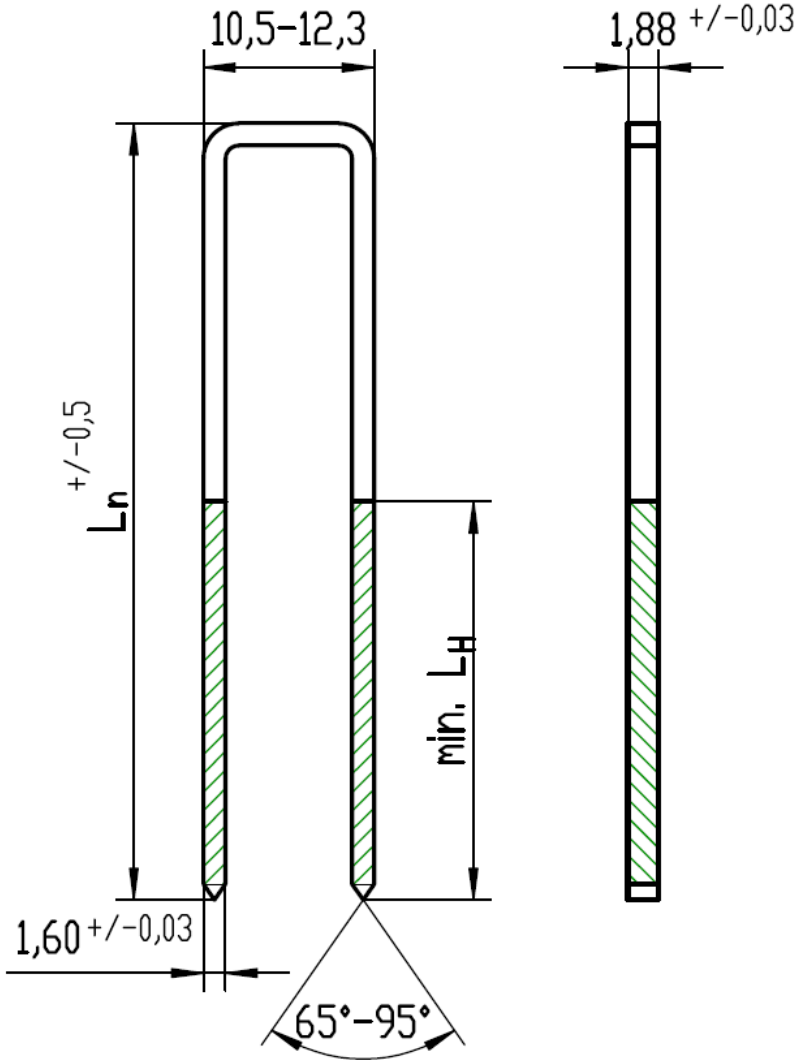

Klammerrohdraht: Verzinkter runder Stahldraht C20 Ø 1,80 +/- 0,03 mm Rm min. 900 N/mm ² A ₁₀₀ min. 3% Ø _n 1,80 $\frac{+}{-0,03^A}$ mm Zinkauflage min. 12µm
Lack, Kleber - Baussmann Typ 1 - Baussmann Typ 2

Schaftlänge L _n [mm]	32,0 bis 115,0
Harzung L _H [mm]	mind. 0,5 L _n >= 22 mm

Staples Type A-154, B-180 and C-203 in galvanised and stainless steel	Annex 1.3
Technical description of the product	
Staples Type B-180 galvanised	

electronic copy of the eta by dibt: eta-17/0333

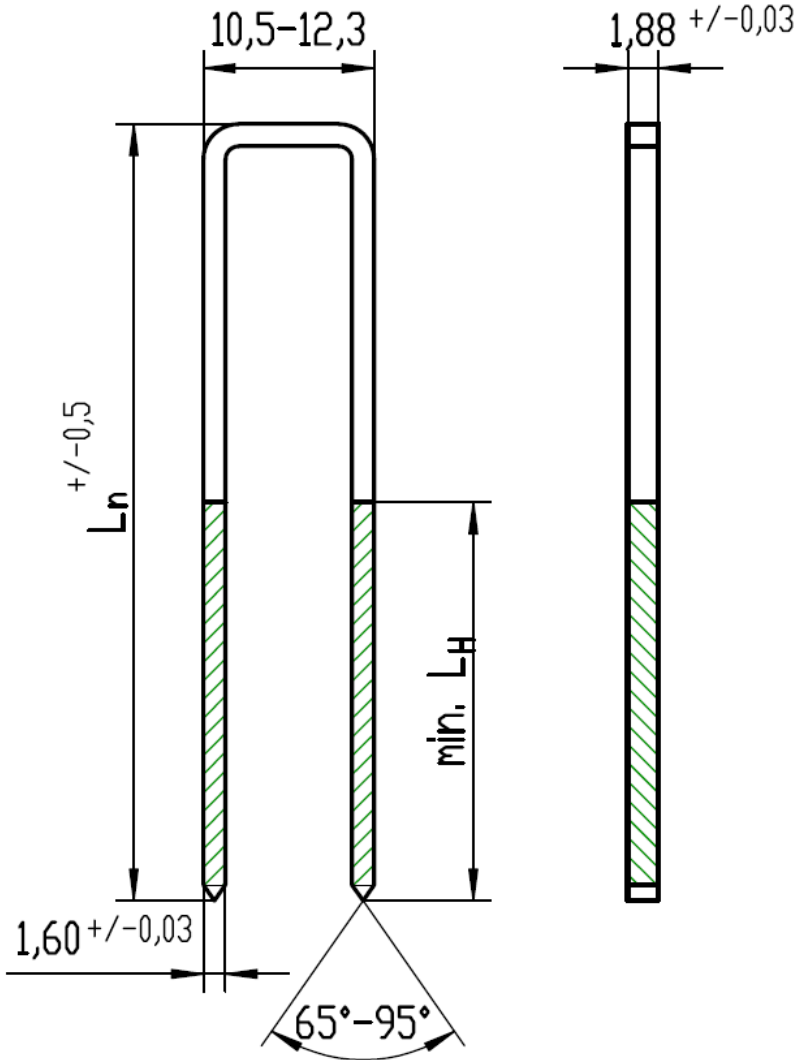

Klammerrohdraht:
Rostfreier runder Edelstahldraht
W.Nr. 1.4301 (AISI 304),
1.4401 (AISI 316); 1.4529
Ø 1,80 +/- 0,03 mm
Rm min. 900 N/mm²
A₁₀₀ min. 5%
Ø_n 1,80 $\frac{+}{-0,03}$ mm

Lack, Kleber

- Baussmann Typ 1
- Baussmann Typ 2

Schaftlänge L_n [mm]	32,0 bis 115,0
Harzung L_H [mm]	mind. 0,5 L_n >= 22 mm

Staples Type A-154, B-180 and C-203 in galvanised and stainless steel	Annex 1.4
Technical description of the product	
Staples Type A-180 stainless steel	

electronic copy of the eta by dibt: eta-17/0333

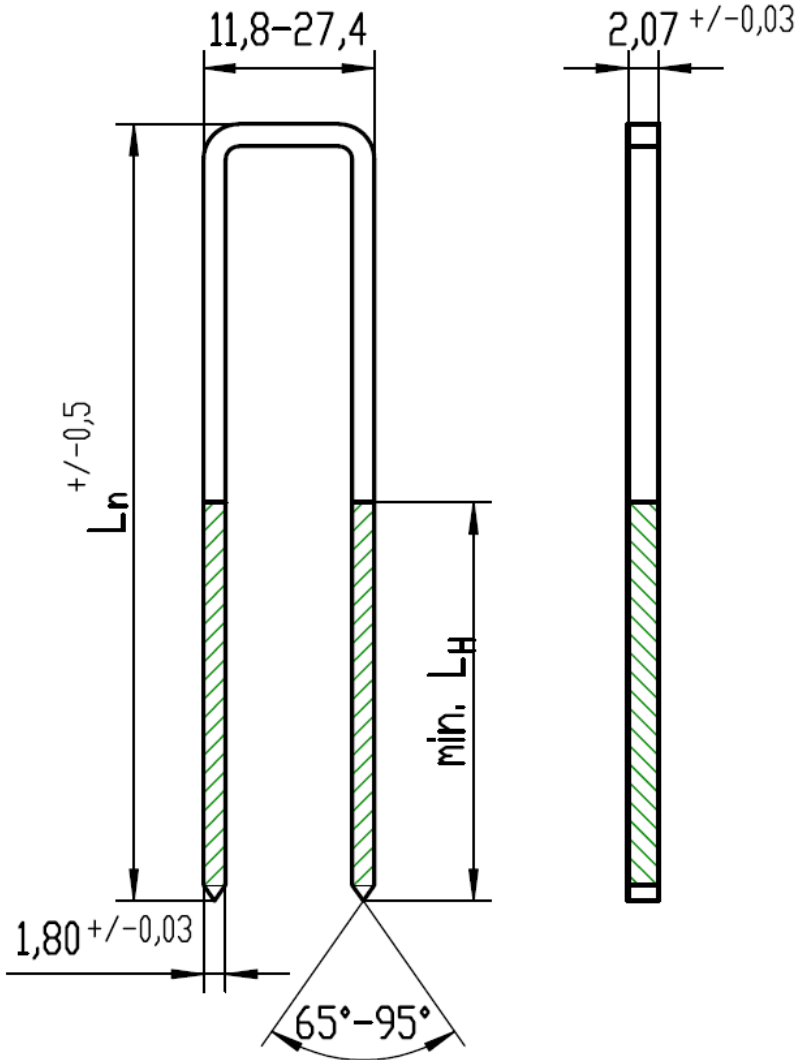

Klammerrohdraht:
Verzinkter runder Stahldraht C20
 $\text{Ø } 2,03 \pm 0,03 \text{ mm}$
 $R_m \text{ min. } 900 \text{ N/mm}^2$
 $A_{100} \text{ min. } 3\%$
 $\text{Ø}_n 2,03 \begin{smallmatrix} + \\ -0,03^A \end{smallmatrix} \text{ mm}$
 Zinkauflage min. $12\mu\text{m}$

Lack, Kleber

- Baussmann Typ 1
- Baussmann Typ 2

Schaftlänge L_n [mm]	36,0 bis 172,0
Harzung L_H [mm]	mind. $0,5 L_n$ $\geq 25 \text{ mm}$

Staples Type A-154, B-180 and C-203 in galvanised and stainless steel	Annex 1.5
Technical description of the product	
Staples Type C-203 galvanised	

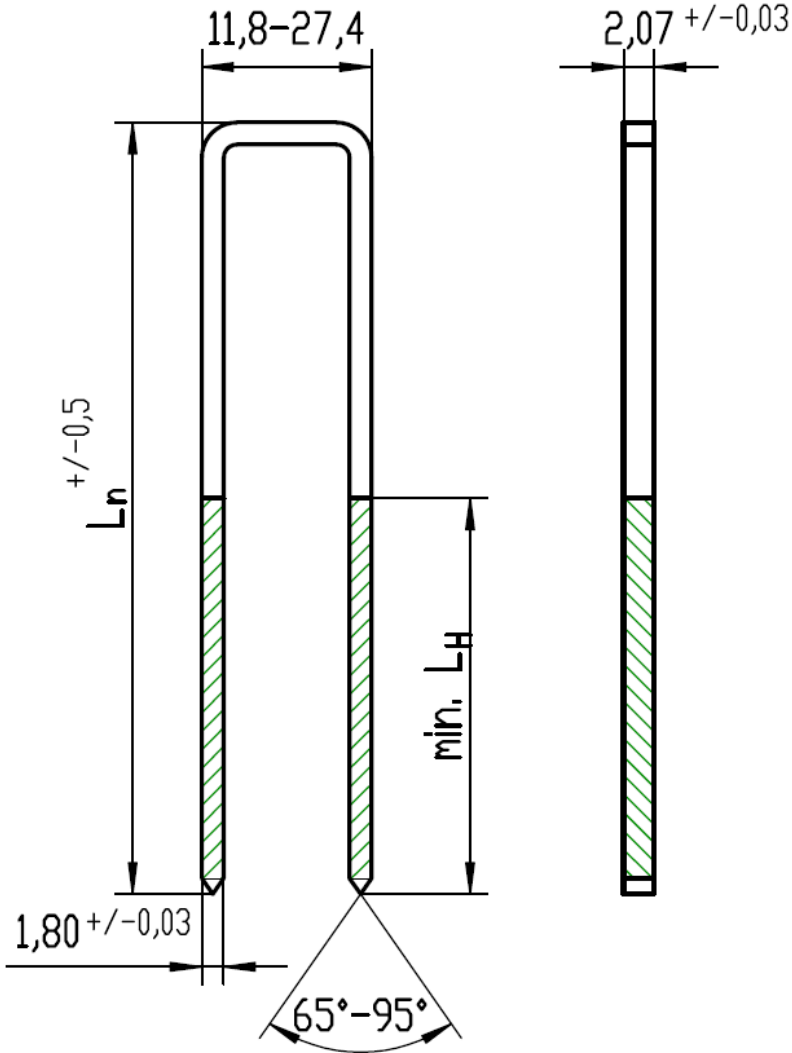

Klammerrohdraht:
Rostfreier runder Edelstahlraht
W.Nr. 1.4301 (AISI 304),
1.4401 (AISI 316); 1.4529
Ø 2,03 +/- 0,03 mm
Rm min. 900 N/mm²
A₁₀₀ min. 5%
Ø_n 2,03 $\frac{+}{-0,03^A}$ mm

Lack, Kleber

- Baussmann Typ 1
- Baussmann Typ 2

Schaftlänge L_n [mm]	36,0 bis 172,0
Harzung L_H [mm]	mind. 0,5 L_n >= 25 mm

Staples Type A-154, B-180 and C-203 in galvanised and stainless steel	Annex 1.6
Technical description of the product	
Staples Type C-203 stainless steel	

electronic copy of the eta by dibt: eta-17/0333

Annex 2 Specifications of intended use

A.2.1 Loading

- Static and quasi-static loads (not relevant to fatigue)
- Short-, medium-, longterm and permanent load duration withdrawal as well as shear

A.2.2 Connection material

Staples Type A-154, B-180 and C-203 are used for load bearing connections of the following material.

Material for base building components

- Solid timber (softwood) according to EN 338¹/ EN 14081-1²,
- Glued laminated timber (softwood) according to EN 14080³,
- Glued solid timber according to EN 14080,
- Laminated veneer lumber LVL according to EN 14374⁴,
- Cross-laminated timber according to European technical approvals/assessments, EN 16351⁵ or national provisions that apply at the installation site.

Material for connected building components

- Oriented Strand Board (OSB) according to EN 300⁶ and EN 13986⁷,
- Plywood according to EN 636⁸ and EN 13986,
- Cement-bonded particle boards according to EN 634-2⁹ and EN 13986,
- Fibreboards according to EN 622-2¹⁰, EN 622-3¹¹ and EN 13986,
- Laminated veneer lumber LVL according to EN 13986 in connection with EN 14279¹²,
- Solid-wood panels according to EN 13353¹³ and EN 13986,
- Gypsum boards according to EN 520¹⁴, density $\rho \geq 680 \text{ kg/m}^3$ but without Typ D,
Gypsum boards Typ D with a density of $\rho \geq 800 \text{ kg/m}^3$
- Gypsum boards with mat reinforcement according to EN 15283-1¹⁵ and Gypsum fibre boards according to EN 15283-2¹⁶
- Fibre-cement flat sheets – Product specification and test methods according to EN 12467¹⁷
- Thermal insulation products for buildings – Factory made wood fibre (WF) products – Specification according to EN 13171¹⁸

1	EN 338:2016	Timber structures - Strength classes
2	EN 14081-1:2016	Timber structures – Strength graded structural timber with rectangular cross section – Part 1: General requirements
3	EN 14080:2013	Timber structures - Glued laminated timber and glued solid timber - Requirements
4	EN 14374:2004	Timber structures - Structural laminated veneer lumber - Requirements
5	EN 16351:2015	Timber structures - Cross laminated timber - Requirements
6	EN 300:2006	Oriented strand boards (OSB) – Definition, classification and specifications
7	EN 13986:2004+A1:2015	Wood-based panels for use in construction - Characteristics, evaluation of conformity and marking
8	EN 636:2012+A1:2015	Plywood - Specifications
9	EN 634-2:2007	Cement-bonded particleboards – Specifications – Part 2: Requirements for OPC bonded particleboards for use in dry, humid and external conditions
10	EN 622-2:2004	Fibreboards - Specifications - Part 2: Requirements for hardboards
11	EN 622-3:2004	Fibreboards - Specifications - Part 3: Requirements for medium boards
12	EN 14279:2009	Laminated Veneer Lumber (LVL) – Definitions, classification and specifications
13	EN 13353:2008+A1:2011	Solid wood panels (SWP) – Requirements
14	EN 520:2004+A1:2009	Gypsum plasterboards – Definitions, requirements and test methods
15	EN 15283-1:2008+A1:2009	Gypsum boards with fibrous reinforcement – Definitions, requirements and test methods – Part 1: Gypsum boards with mat reinforcement
16	EN 15283-2:2008+A1:2009	Part 2: Gypsum fibre boards Gypsum boards with fibrous reinforcement – Definitions, requirements and test methods – Part 2: Gypsum fibre boards
17	EN 12467:2012+A1:2016	Fibre-cement flat sheets – Product specification and test methods
18	EN 13171:2012	Thermal insulation products for buildings – Factory made wood fibre (WF) products – Specification

A.2.3 Use conditions (environmental conditions)

A.2.3.1 Durability against corrosion

Staples Type A-154, B-180 and C-203 made of non-alloy steel rods are galvanized. The mean thickness of the zinc coating is 12 µm. Steel no. 1.4301 (V2a), 1.4401 (V4a) and 1.4529 are used for Staples Type A-154, B-180 and C-203 made of stainless steel.

A.2.3.2 Durability of the resin coating

The resin coating l_H of Staples Type A-154, B-180 and C-203 has a minimum length of 50 % of the legs according to Annex 1. The following kinds of resin are used:

- Bausmann Kleber Typ 1
- Bausmann Kleber Typ 2

Data sheets of chemical compositions (as well as the process of application and drying for resin coatings) are deposited at Deutsches Institut für Bautechnik.

The resin coating fulfills the requirements of the EAD 130019-00-0603, clause 2.2.9 "durability of the resin coating".

A.2.3.3 Installation provisions

EN 1995-1-1¹⁹ in conjunction with the respective national annex applies for the installation.

The insertion of the staples has to be at least 14·d.

For connections of wood fibre insulation material the maximum length of the leg is $l = 85\cdot d$, the minimum width is $b=20\text{mm}$ and the maximum thickness of the insulation is 70·d.

¹⁹ EN 1995-1-1:2004+A1:2008+A2:2014

Annex 3 Specifications of essential characteristics

A.3.1 Characteristic yield moment according to EN 14592

Table A.3.1 Characteristic yield moment $M_{y,k}$ [Nm] of one leg of staples Type A to C

Type	Nominal diameter d in mm	Yield moment $M_{y,k}$ in Nm	
		Galvanised	Stainless steel
Type A-154	1,54	0,72	0,71
Type B-180	1,80	0,94	1,05
Type C-203	2,03	1,56	1,42

A.3.2 Withdrawal capacity for short-term and medium-term loads

The characteristic withdrawal parameters of one leg (at an angle of at least 30° between the width of staple crown and the direction of the grain) for material with a characteristic density $\rho_k \geq 350 \text{ kg/mm}^2$ for short-term and medium-term withdrawal loads can be taken from Table A.3.2:

Tabelle A.3.2 Characteristic withdrawal parameter $f_{ax,k}$ of one leg of staples Typ A bis C

Type	Nominal diameter d in mm	Withdrawal parameter short- and medium-term $f_{ax,k}$ in N/mm ²
Type A-154	1,54	4,91
Type B-180	1,80	4,97
Type C-203	2,03	5,54

The maximum length of staples in the supporting system has to be not more than 20·d in calculations.

A.3.3 Design value of withdrawal capacity for long-term and permanent loads

The design value of withdrawal capacity for long-term and permanent loads for service class 1 and 2 for one staple may be taken to:

$$R_{ax,d} = 70 \text{ N, mit } \gamma_M = 1,3.$$

The design value of withdrawal capacity applies for a characteristic density of $\rho_k \geq 350 \text{ kg/m}^3$

A.3.4 Maximum thickness of connected material

The maximum thickness t_1 of connected material depending on its density has to be in accordance with Table A.3.3:

Table A.3.3 Maximum thickness of connected material

Maximum thickness t_1 [mm]	Range of density ρ_k [kg/m ³]	Material of connected components Examples
80	$\rho_k \leq 400$	Solid timber of softwood
60	$400 < \rho_k \leq 650$	Wood-based panels and solid timber of hard- and softwood
40	$650 < \rho_k \leq 900$	Wood-based panels and gypsum boards
25	$900 < \rho_k \leq 1200$	Hardboards, gypsum fibreboards, cement-bonded particleboards
20	$1200 < \rho_k \leq 1600$	Highly compressed gypsum fibreboards

The maximum thickness of wood fibre insulation material has to be within $t_1 \leq 70 \cdot d$.

A.3.5 Head pull-through capacity of wood and wood-based panels

The characteristic head pull-through parameters $f_{\text{head},k}$ for one staple of Staples Type A to C for a minimum thickness of material according to Table A.3.4 (for material with a characteristic density of $\rho_k \geq 350 \text{ kg/m}^3$) can be taken from Table A.3.5:

Table A.3.4 Minimum thickness of wood and wood-based panels

Wood or wood-based panels	Minimum thickness in t_1 [mm]
Solid timber (softwood)	24
Solid wood panels	7d*
Plywood	6*
Oriented Strand Boards OSB	8*
Resin-bonded particleboards	8*
Cement-bonded particleboards	8*

* if staple crown is countersunk it has to be increased by 2 mm

The characteristic head pull-through capacity may be calculated according to equation (1)

$$R_{\text{ax},2,k} = f_{\text{head},k} \cdot b \cdot d \quad \text{N} \quad (1)$$

mit:

$f_{\text{head},k}$: characteristic head pull-through parameter in N/mm^2

b: width of staple crown in mm, in calculations the maximum width may be $b = 27 \text{ mm}$

d: nominal diameter of raw staple wire in mm

Table A.3.5 Characteristic head pull-through parameter $f_{\text{head},k}$ for material $\rho_k \geq 350 \text{ kg/m}^3$

Type	Nominal diameter d in mm	Width of staple crown b_{min} in mm	Head pull-through parameter $f_{\text{head},k}$ in N/mm^2
Type A-154	1,53	9,00	41
Type B-180	1,80	10,50	32
Type C-203	2,03	11,80	29
		26,00	39

A.3.6 Head pull-through capacity of wood fibre insulation material

The characteristic head pull-through parameter $f_{\text{head},k}$ of Staples Type A-154, B-180 and C-203 for wood fibre insulation material with a mean density of at least 200 kg/m^3 and a minimum thickness of the material of 60 mm is $f_{\text{head},k} = 9,36 \text{ N/mm}^2$ for one staple. The width of the staple crown has to be at least 20 mm.

A.3.7 Head pull-through capacity of other kind of boards

The characteristic head pull-through parameter for material in accordance with A.2.2 regulated in technical approvals may be taken out of it.

A.3.8 Minimum tensile strength of the wire

Table A.3.4 Minimum tensile strength f_u [N/mm^2] of the raw wire of staples Type A to C

Nominal diameter d in mm	1,54	1,80	2,00
Galvanised	900		
Stainless steel	900		