

Approval body for construction products
and types of construction

Bautechnisches Prüfamt

An institution established by the Federal and
Laender Governments



European Technical Assessment

ETA-17/0078
of 10 March 2017

English translation prepared by DIBt - Original version in German language

General Part

Technical Assessment Body issuing the
European Technical Assessment:

Deutsches Institut für Bautechnik

Trade name of the construction product

Baumit S and Baumit N

Product family
to which the construction product belongs

Screwed-in plastic anchor and nailed-in plastic anchor for
the fixing of external thermal insulation composite
systems with rendering in concrete and masonry

Manufacturer

Baumit Beteiligungen GmbH
Wopfung 156
2754 WALDEGG
ÖSTERREICH

Manufacturing plant

Baumit 1, 2, 3, 4

This European Technical Assessment
contains

23 pages including 3 annexes which form an integral part
of this assessment

This European Technical Assessment is
issued in accordance with Regulation (EU)
No 305/2011, on the basis of

European Assessment Document (EAD)
330335-00-0604

The European Technical Assessment is issued by the Technical Assessment Body in its official language. Translations of this European Technical Assessment in other languages shall fully correspond to the original issued document and shall be identified as such.

Communication of this European Technical Assessment, including transmission by electronic means, shall be in full. However, partial reproduction may only be made with the written consent of the issuing Technical Assessment Body. Any partial reproduction shall be identified as such.

This European Technical Assessment may be withdrawn by the issuing Technical Assessment Body, in particular pursuant to information by the Commission in accordance with Article 25(3) of Regulation (EU) No 305/2011.

Specific Part

1 Technical description of the product

The screwed-in anchor Baunit S consists of an anchor sleeve with an enlarged shaft, spreading zone subsequently, an insulation plate made of polyamide and an accompanying specific screw of galvanised steel or stainless steel. The serrated expanding part of the anchor sleeve is slotted.

The nailed-in anchor Baunit N consists of an anchor sleeve with an enlarged shaft, spreading zone subsequently, an insulation plate made of polyamide and an accompanying specific nail of galvanised steel with an overmoulding of polyamide. The serrated expanding part of the anchor sleeve is slotted.

The anchors Baunit S and Baunit N may in addition be combined with the anchor plates SBL 140 plus and VT 90. The anchor Baunit S may in addition be combined with the anchor plate VT 2G.

An illustration and the description of the product are given in Annex A.

2 Specification of the intended use in accordance with the applicable European Assessment Document

The performances given in Section 3 are only valid if the anchor is used in compliance with the specifications and conditions given in Annex B.

The verification and assessment methods on which this European Technical Assessment is based lead to the assumption of a working life of the anchor of at least 25 years. The indications given on the working life cannot be interpreted as a guarantee given by the producer, but are to be regarded only as a means for choosing the right products in relation to the expected economically reasonable working life of the works.

3 Performance of the product and references to the methods used for its assessment

3.1 Mechanical resistance and stability (BWR 1)

Essential characteristic	Performance
Characteristic tension resistance	See Annex C 1
Edge distances and spacing	See Annex B 2
Plate stiffness	See Annex C 2
Displacements	See Annex C 2

3.2 Energy economy and heat retention (BWR 6)

Essential characteristic	Performance
Point thermal transmittance	See Annex C 2

English translation prepared by DIBt

4 Assessment and verification of constancy of performance (AVCP) system applied, with reference to its legal base

In accordance with EAD No. 330335-00-0604, the applicable European legal act is: [97/463/EC].

The system to be applied is: 2+

5 Technical details necessary for the implementation of the AVCP system, as provided for in the applicable EAD

Technical details necessary for the implementation of the AVCP system are laid down in the control plan deposited with Deutsches Institut für Bautechnik.

Issued in Berlin on 10 March 2017 by Deutsches Institut für Bautechnik

Uwe Bender
Head of Department

beglaubigt:
Ziegler

Baumit S, mounting flushed at the surface

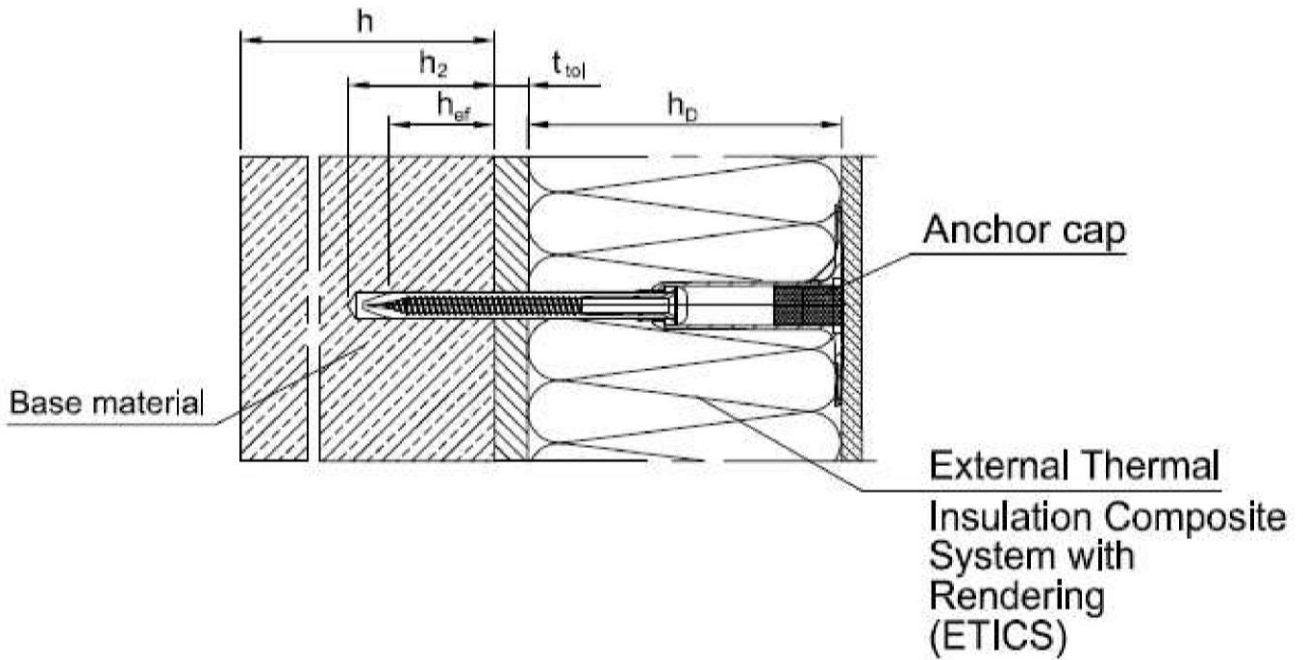

Intended use

- Anchorage of ETICS in concrete and masonry
- Anchorage of ETICS in autoclaved aerated concrete and lightweight aggregate concrete

Legend:

- h_D = thickness of insulation material
- h_{ef} = effective anchorage depth
- h = thickness of member (wall)
- h_2 = depth of drilled hole to deepest point
- t_{tol} = thickness of equalizing layer or non-load-bearing coating

Baunit S and Baunit N

Product description

Installed condition Baunit S, flushed at the surface

Annex A 1

Baunit S / use category A,B,C,D, / mounting flushed at the surface

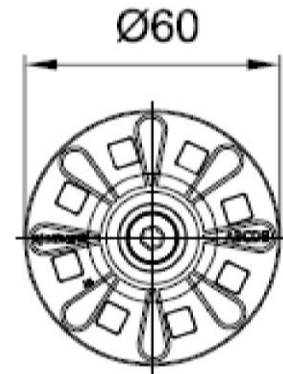
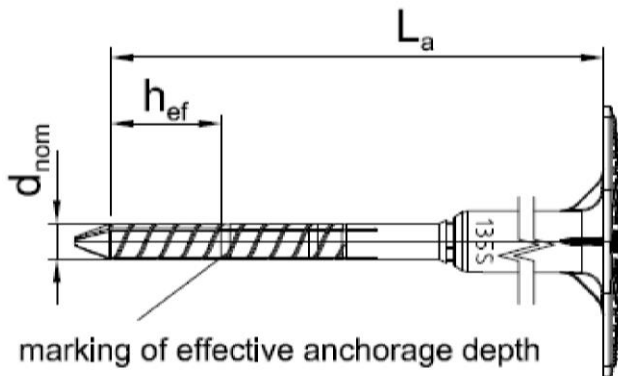

Marking:
Anchor type (e.g. Baunit S)
Length of anchor (e.g. 135)
Use category (A,B,C,D,E)



Tabelle A 1: Dimensions

Anchor type	d _{nom} [mm]	Anchor sleeve		d _s [mm]	Specific screw		Anchor cap	
		h _{ef} [mm]	min L _a max L _a [mm]		c [mm]	min l _s max l _s [mm]	d _c [mm]	h _c [mm]
Baunit S	8	25	115 295	5,5	60	88 188	12,5	23

Determination of maximum thickness of insulation h_D [mm] Baunit S:

$$h_D = L_a - t_{tol} - h_{ef} \quad (L_a = \text{e.g. } 215; t_{tol} = 10)$$

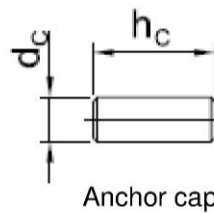
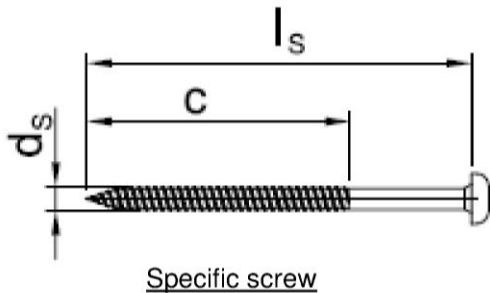
e.g. h_D = 215 - 10 - 25

h_{Dmax} = 180

Baunit S and Baunit N

Product description

Baunit S - Marking and dimensions, use category: A,B,C,D
mounting flushed at the surface

Annex A 2

Baumit S / use category E / mounting flushed at the surface

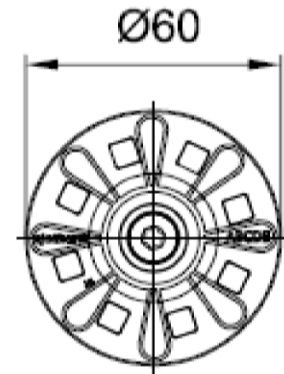
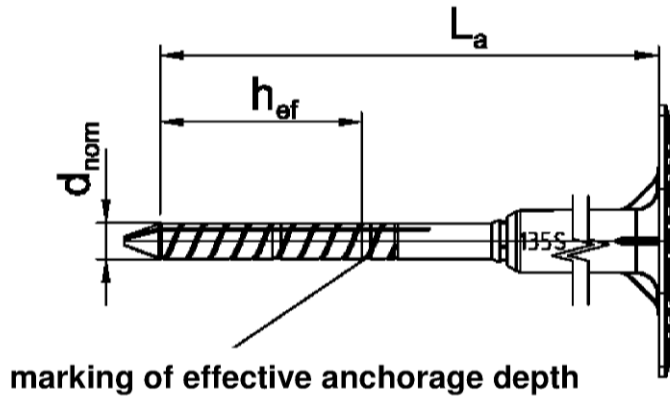

Marking:
Anchor type (e.g. Baumit S)
Length of anchor (e.g. 135)
Use category (A,B,C,D,E)

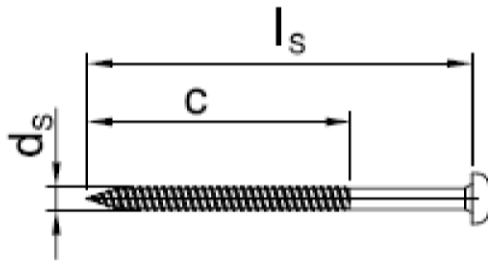

Specific screw

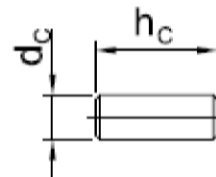

Anchor Cap

Tabelle A 1: Dimensions

Anchor type	Anchor sleeve			Specific screw			Anchor cap	
	d_{nom} [mm]	h_{ef} [mm]	min L_a max L_a [mm]	d_s [mm]	c [mm]	min l_s max l_s [mm]	d_c [mm]	h_c [mm]
Baumit S	8	45	115 295	5,5	60	88 188	12,5	23

Determination of maximum thickness of insulation h_D [mm] Baumit S:

$$h_D = L_a - t_{tol} - h_{ef} \quad (L_a = \text{e.g. } 215; t_{tol} = 10)$$

e.g. $h_D = 215 - 10 - 45$
 $h_{Dmax} = 160$

Baumit S and Baumit N

Product description

Baumit S - Marking and dimensions, use category: E mounting flushed at the surface

Annex A 3

Baunit S, countersunk into insulation

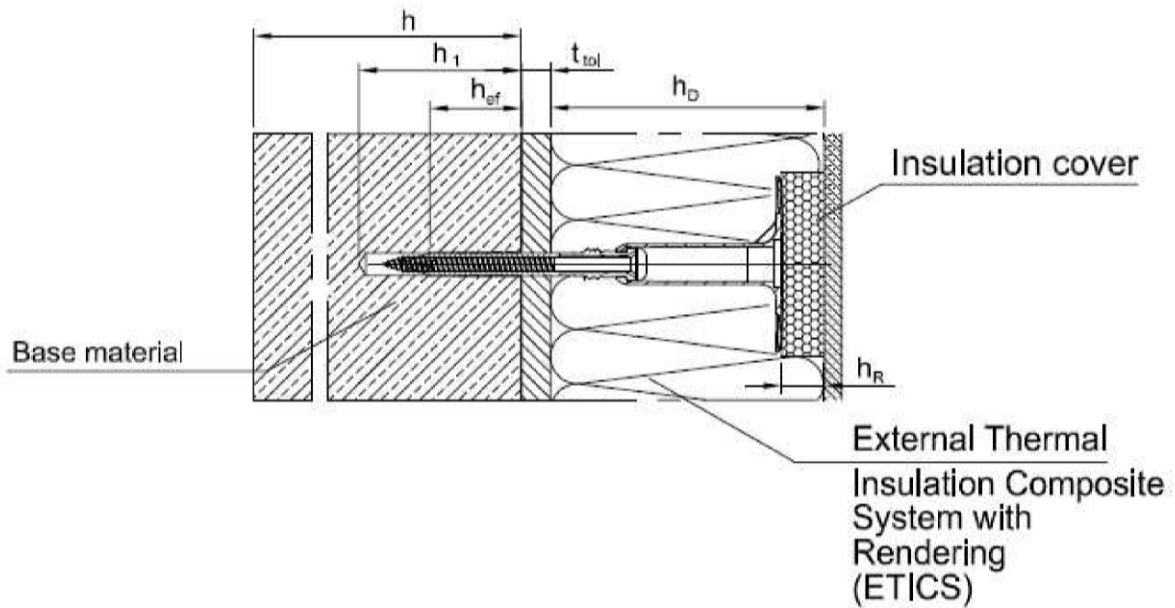

Intended use

- Anchorage of ETICS in concrete and masonry
- Anchorage of ETICS in autoclaved aerated concrete and lightweight aggregate concrete

Legend:

- h_D = thickness of insulation material
- h_{ef} = effective anchorage depth
- h = thickness of member (wall)
- h_1 = depth of drilled hole to deepest point
- h_R = thickness insulation cover
- t_{tol} = thickness of equalizing layer or non-load-bearing coating

Baunit S and Baunit N

Product description

Installed condition Baunit S, countersunk into insulation

Annex A 4

Baunit S / use category A, B, C, D / countersunk into insulation

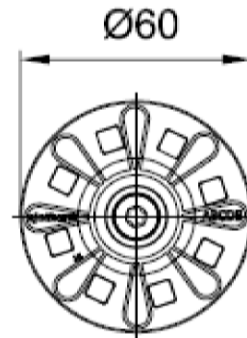
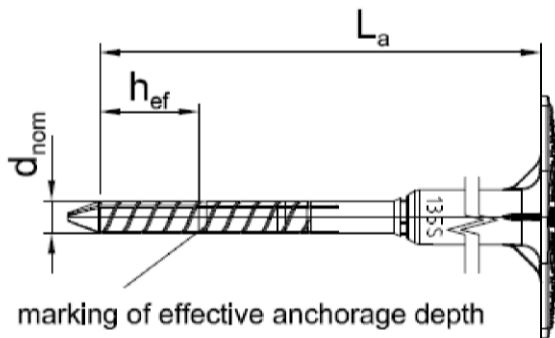

Marking:
Anchor type (Baunit S)
Anchor length (e.g. 135)
Use category (A,B,C,D,E)

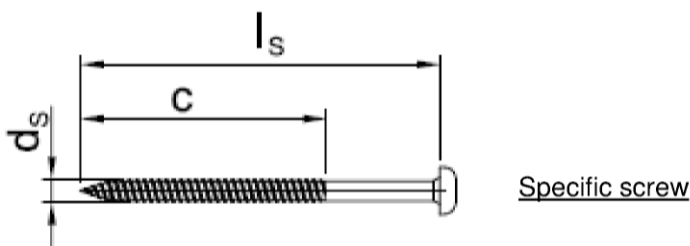

Insulation cover

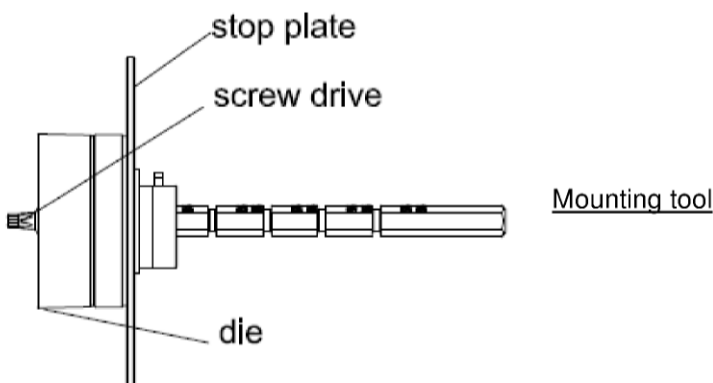
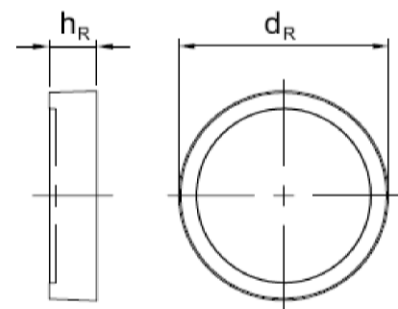

Table A 3: Dimensions

Anchor type	Anchor sleeve			Specific screw			Insulation cover	
	d_{nom} [mm]	h_{ef} [mm]	min L_a max L_a [mm]	d_s [mm]	c [mm]	min l_s max l_s [mm]	h_R	d_R
Baunit S	8	25	115 - 295	5,5	60	88 - 188	15	65

Determination of maximum thickness of insulation h_D [mm] Baunit S:

$$h_D = L_a - t_{tol} - h_{ef} \quad (L_a = \text{e.g. } 215; t_{tol} = 10)$$

$$\text{e.g. } h_D = 215 - 10 - 25$$

$$h_{Dmax} = 180$$

Baunit S und Baunit N

Product description

Baunit S - Marking and dimensions, mounting tool, use category: A,B,C,D, countersunk into insulation

Annex A 5

Baunit S / use category E / countersunk into insulation

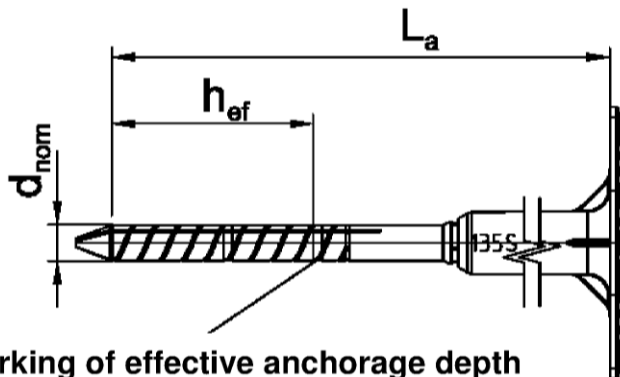

marking of effective anchorage depth

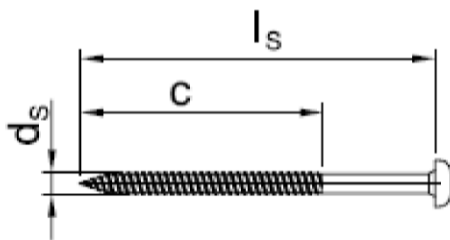

Specific screw

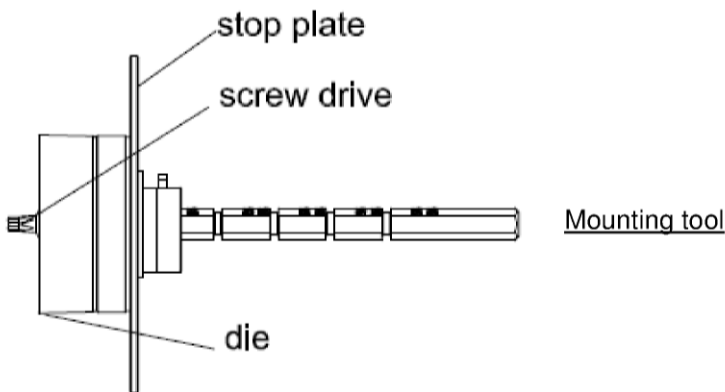

Mounting tool

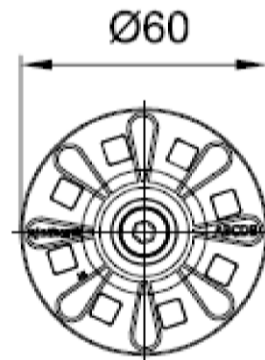

Marking:
Anchor type (Baunit S)
Anchor length (e.g. 135)
Use category (A,B,C,D,E)

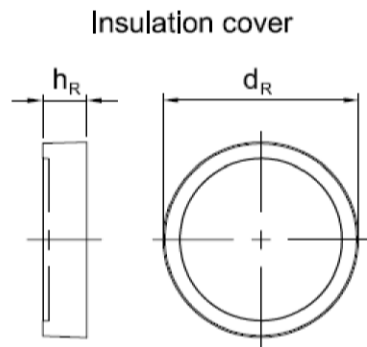

Insulation cover

Table A 3: Dimensions

Anchor type	Anchor sleeve			Specific screw			Insulation cover	
	d_{nom} [mm]	h_{ef} [mm]	min L_a max L_a [mm]	d_s [mm]	c [mm]	min l_s max l_s [mm]	h_R	d_R
Baunit S	8	45	115 - 295	5,5	60	88 - 188	15	65

Determination of maximum thickness of insulation h_D [mm] Baunit S:

$$h_D = L_a - t_{tol} - h_{ef} \quad (L_a = \text{e.g. } 215; t_{tol} = 10)$$

e.g. $h_D = 215 - 10 - 45$

$$h_{Dmax} = 160$$

Baunit S und Baunit N

Product description

Baunit S - Marking and dimensions, mounting tool,
use category: E, countersunk into insulation

Annex A 6

Baunit N, flushed at the surface

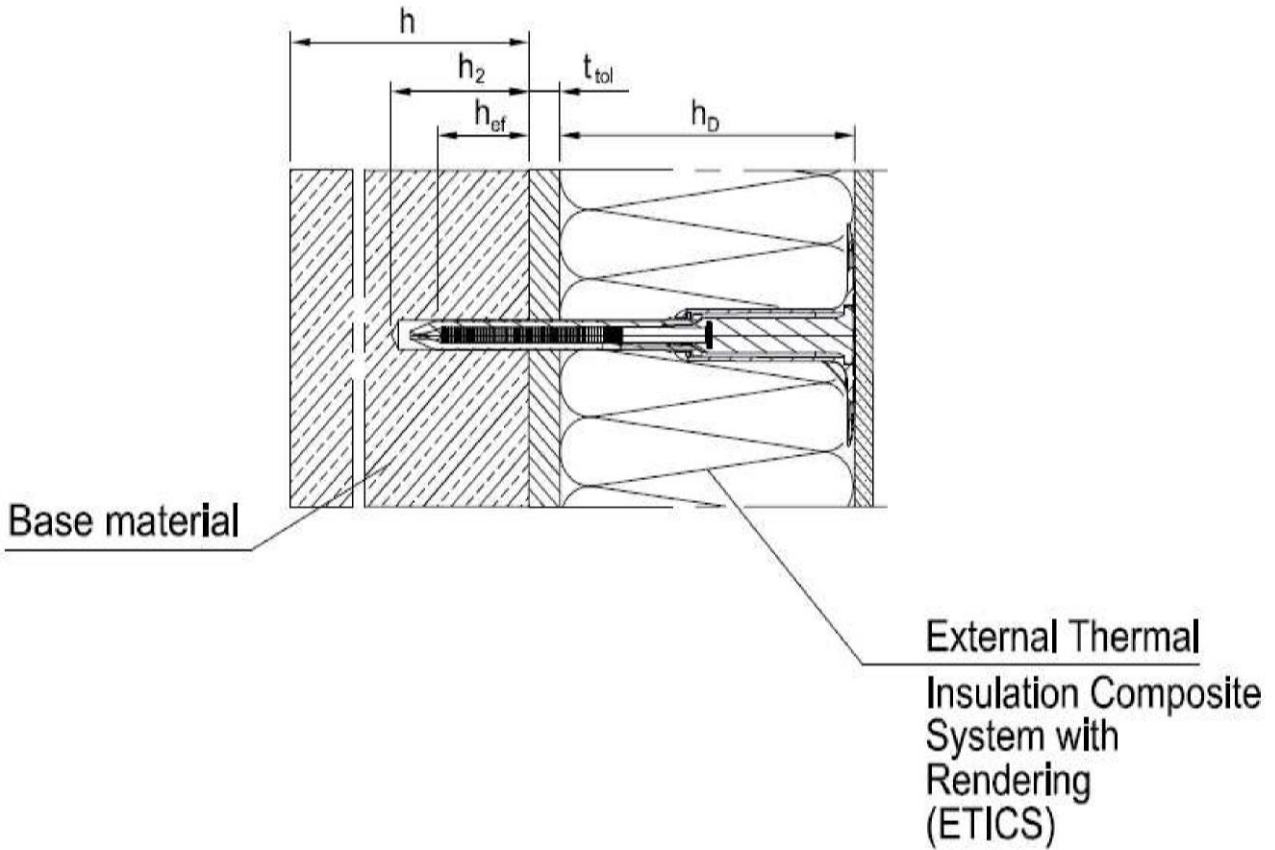

Intended use

- Anchorage of ETICS in concrete and masonry
- Anchorage of ETICS in autoclaved aerated concrete and lightweight aggregate concrete

Legend:

- h_D = thickness of insulation material
- h_{ef} = effective anchorage depth
- h = thickness of member (wall)
- h_2 = depth of drilled hole to deepest point
- t_{tol} = thickness of equalizing layer or non-load-bearing coating

Baunit S and Baunit N

Product description

Installed condition Baunit N, flushed at the surface

Annex A 7

Baunit N / use category A,B,C,D / mounting flushed at the surface

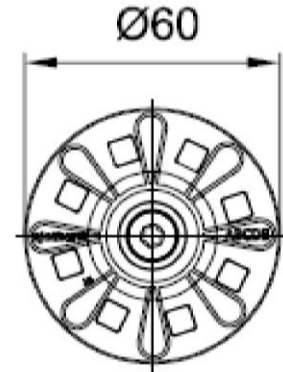
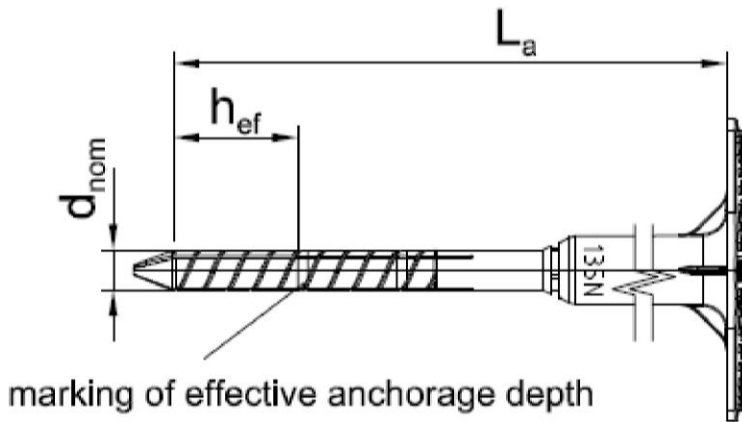

Marking:
Anchor type (Baunit N)
Anchor length (e.g. 135)
Use category (A,B,C,D,E)

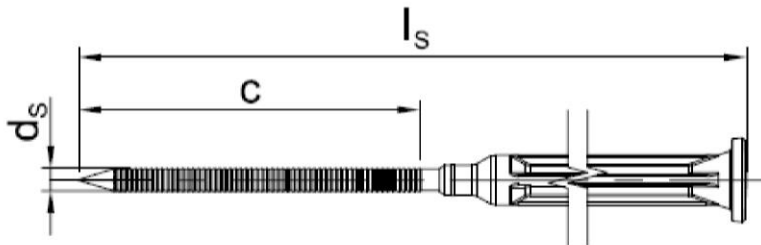

Specific nail

Table A 5: Dimensions

Anchor Type	Anchor Sleeve			Specific nail		
	d_{nom} [mm]	h_{ef} [mm]	min L_a max L_a [mm]	d_n [mm]	c [mm]	min l_n max l_n [mm]
Baunit N	8	25	95 -295	4,13	60	95 295

Determination of maximum thickness of insulation h_D [mm] Baunit N:

$$h_D = L_a - t_{tol} - h_{ef} \quad (L_a = \text{e.g. } 215; t_{tol} = 10)$$

e.g. $h_D = 215 - 10 - 25$
 $h_{Dmax} = 180$

Baunit S and Baunit N

Product description

Baunit N - Marking and dimensions, use category: A,B,C,D
Mounting flushed at the surface

Annex A 8

Baunit N / use category E / mounting flushed at the surface

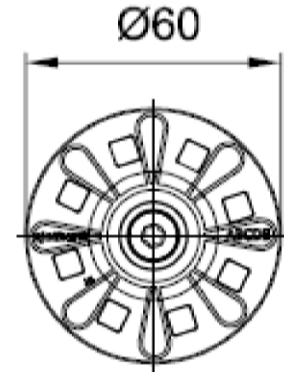
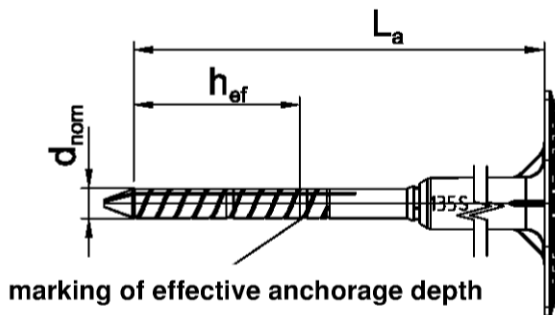

Marking:
Anchor type (Baunit N)
Anchor length (e.g. 135)
Use category (A,B,C,D,E)

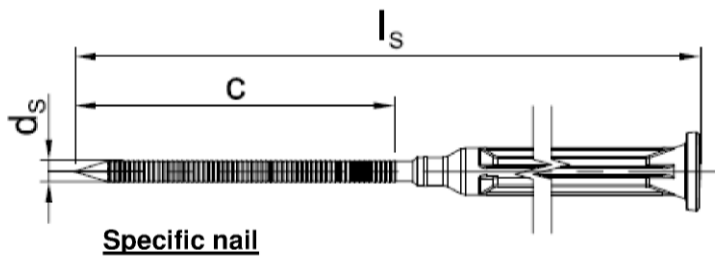

Table A 5: Dimensions

Anchor Type	Anchor Sleeve			Specific nail		
	d_{nom} [mm]	h_{ef} [mm]	min L_a max L_a [mm]	d_n [mm]	c [mm]	min l_n max l_n [mm]
Baunit N	8	45	95 295	4,13	60	95 295

Determination of maximum thickness of insulation h_D [mm] for Baunit N:

$$h_D = L_a - t_{tol} - h_{ef} \quad (L_a = \text{e.g. } 215; t_{tol} = 10)$$

e.g. $h_D = 215 - 10 - 45 = 160$

Baunit S and Baunit N

Product description

Baunit N - marking and dimensions, use category: E
mounting flushed at the surface

Annex A 9

Table A7: Materials Baunit S + N

Anchor sleeve	Polyethylene, PE-HD, colour: grey
Anchor plate	Polyamide, PA GF 50, colour: red
Plastic moulding of the nail	Polyamide, PA GF 50, colour: black
Insulation cover	Polystyrene EPS 20
	Mineralwool HD
Anchor cap	Polystyrene EPS 30
Specific screw for Baunit S	Steel 5.8, electro galvanized $\geq 5 \mu\text{m}$ according to EN ISO 4042:2001, blue passivated
	Stainless steel, according to ISO 3506 material number 1.4401 or 1.4571 material number 1.4301 or 1.4567
Specific nail for Baunit N	Steel, electro galvanized $\geq 5 \mu\text{m}$ according to EN ISO 4042:2001, blue passivated, $f_{yk} \geq 670 \text{ N/mm}^2$

Baunit S and Baunit N

Product description

Materials of Baunit S and Baunit N

Annex A 10

Baumit S + N

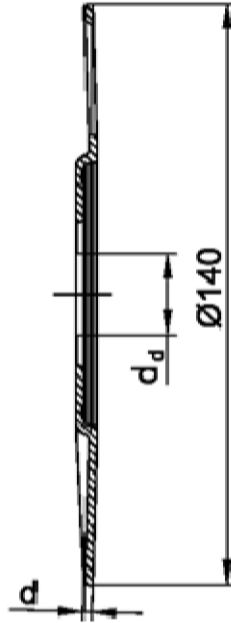
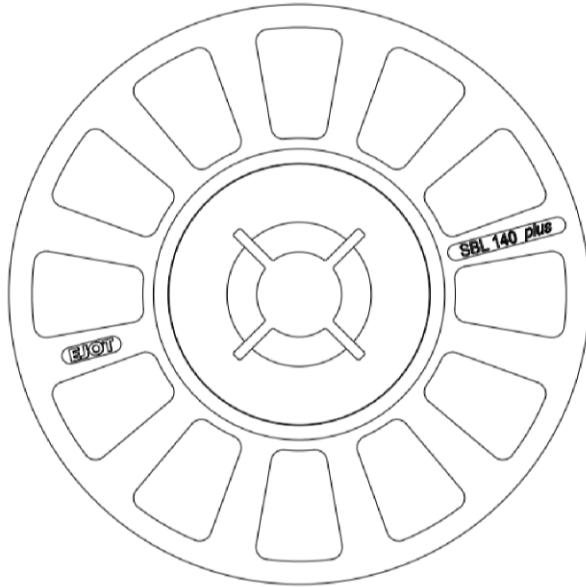

SBL 140 plus	
colour	nature
d_d [mm]	20,0
d [mm]	2,0
Material	^{1) 2)}

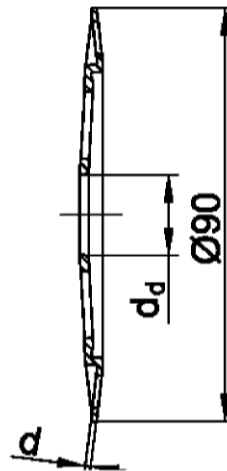
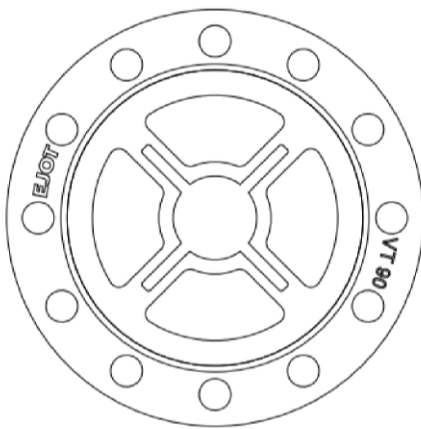

VT 90	
colour	nature
d_d [mm]	17,5
d [mm]	1,2
Material	^{1) 2)}

- 1) Polyamide, PA 6
- 2) Polyamide, PA GF 50

Baumit S and Baumit N

Product description

Slip on plates with Baumit S and Baumit N

Annex A 11

Baunit S

VT 2G

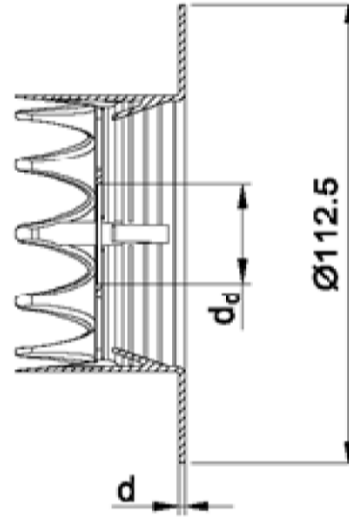
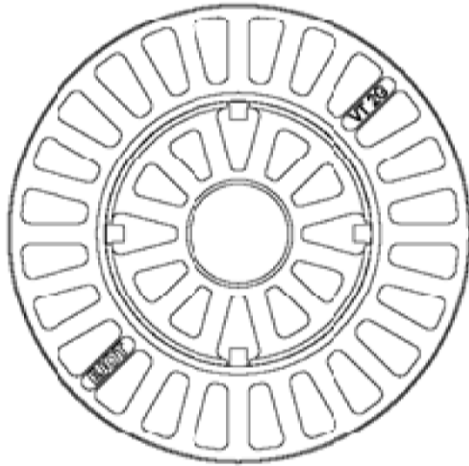

VT 2G	
colour	nature
d_d [mm]	29,0
d [mm]	1,5
Material	¹⁾

¹⁾ Polyamide, PA GF 50

electronic copy of the eta by dibt: eta-17/0078

Baunit S and Baunit N

Product description
Slip on plates with Baunit S

Annex A 12

Specifications of intended use

Anchorage subject to:

- The anchor may only be used for transmission of wind suction loads and shall not be used for the transmission of dead loads of the thermal insulation composite system.

Base materials:

- Normal weight concrete (use category A) according to Annex C1.
- Solid masonry (use category B), according to Annex C1.
- Hollow or perforated masonry (use category C), according to Annex C1.
- Lightweight aggregate concrete (use category D), according to Annex C1.
- autoclaved aerated concrete (use category E), according to Annex C1.
- For other base materials of the use categories A, B, C, D or E the characteristic resistance of the anchor may be determined by job site tests according to EOTA Technical Report TR 051 edition December 2016.

Temperature Range:

- 0°C to +40°C (max. short term temperature +40°C and max. long term temperature +24°C)

Design:

- The anchorages are designed in accordance with the EAD 330335-00-0604 under the responsibility of an engineer experienced in anchorages and masonry work.
- Verifiable calculation notes and drawings are prepared taking account of the loads to be anchored. The position of the anchor is indicated on the design drawings.
- Fasteners are only to be used for multiple fixings of thermal insulation composite systems.

Installation:

- Hole drilling by the drill modes according to Annex C1.
- Anchor installation carried out by appropriately qualified personnel and under the supervision of the person responsible for technical matters of the site.
- Installation temperature from 0°C to +40°C
- Exposure to UV due to solar radiation of the anchor not protected by rendering ≤ 6 weeks

Baumit S and Baumit N

Intended use
Specifications

Annex B 1

Table B1: Installation parameters

Anchor type		Baumit N		Baumit S	
		A B C D	E	A B C D	E
Drill hole diameter	d_0 [mm] =	8	8	8	8
Cutting diameter of drill bit	d_{cut} [mm] ≤	8,45	8,45	8,45	8,45
Depth of drill hole to deepest point					
- deep mounting	h_1 [mm] ≥			50	70
- mounting on the surface	h_1 [mm] ≥	35	55	35	55
Effective anchorage depth	h_{ef} [mm] ≥	25	45	25	45

Table B2: Anchor distances and dimensions of members

Anchor type		Baumit S / Baumit N
Minimum allowable spacing	$s_{min} \geq$ [mm]	100
Minimum allowable edge distance	$c_{min} \geq$ [mm]	100
Minimum thickness of member		
- deep mounting	$h \geq$ [mm]	100
		40 (only skins of concrete)
- mounting on the surface	$h \geq$ [mm]	100
		40 (only skins of concrete)

Scheme of distance and spacing

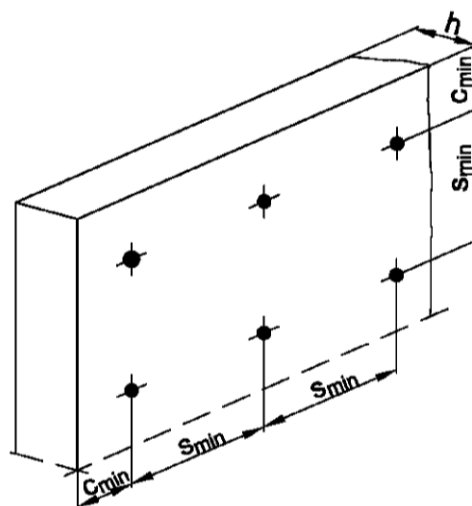

Baumit S and Baumit N

Intended use

Installations parameters,
Edge distances and spacing

Annex B 2

Installation instructions: Baunit S / flushed at the surface

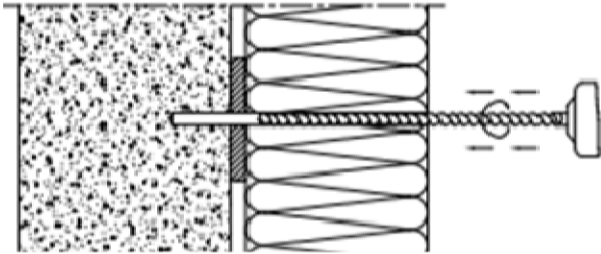

Drill the hole perpendicular to the substrate surface.
Clean the drill hole 3x.

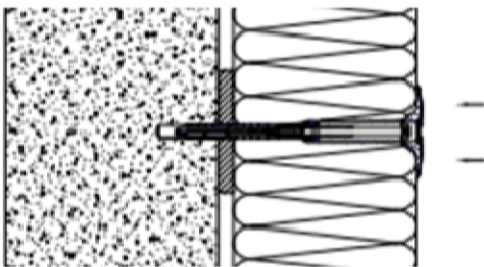

Place the anchor into the drill hole. The bottom side of the plate must be flush with the ETICS.

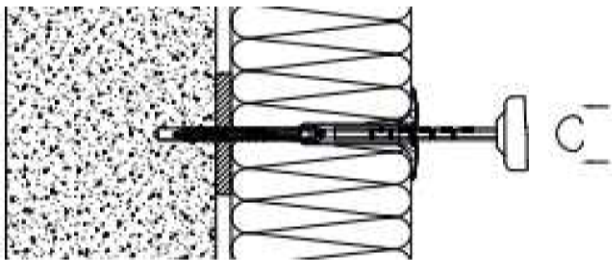

Drill the specific screw into the anchor.

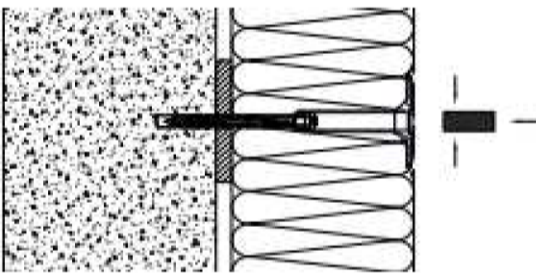

Put the EPS-cap into the anchor

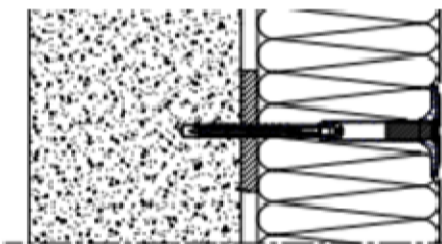

Installed condition of Baunit S.

Baunit S and Baunit N

Intended use

Installation instructions Baunit S, flushed at the surface

Annex B 3

Installation instructions: Baumit S / countersunk into insulation

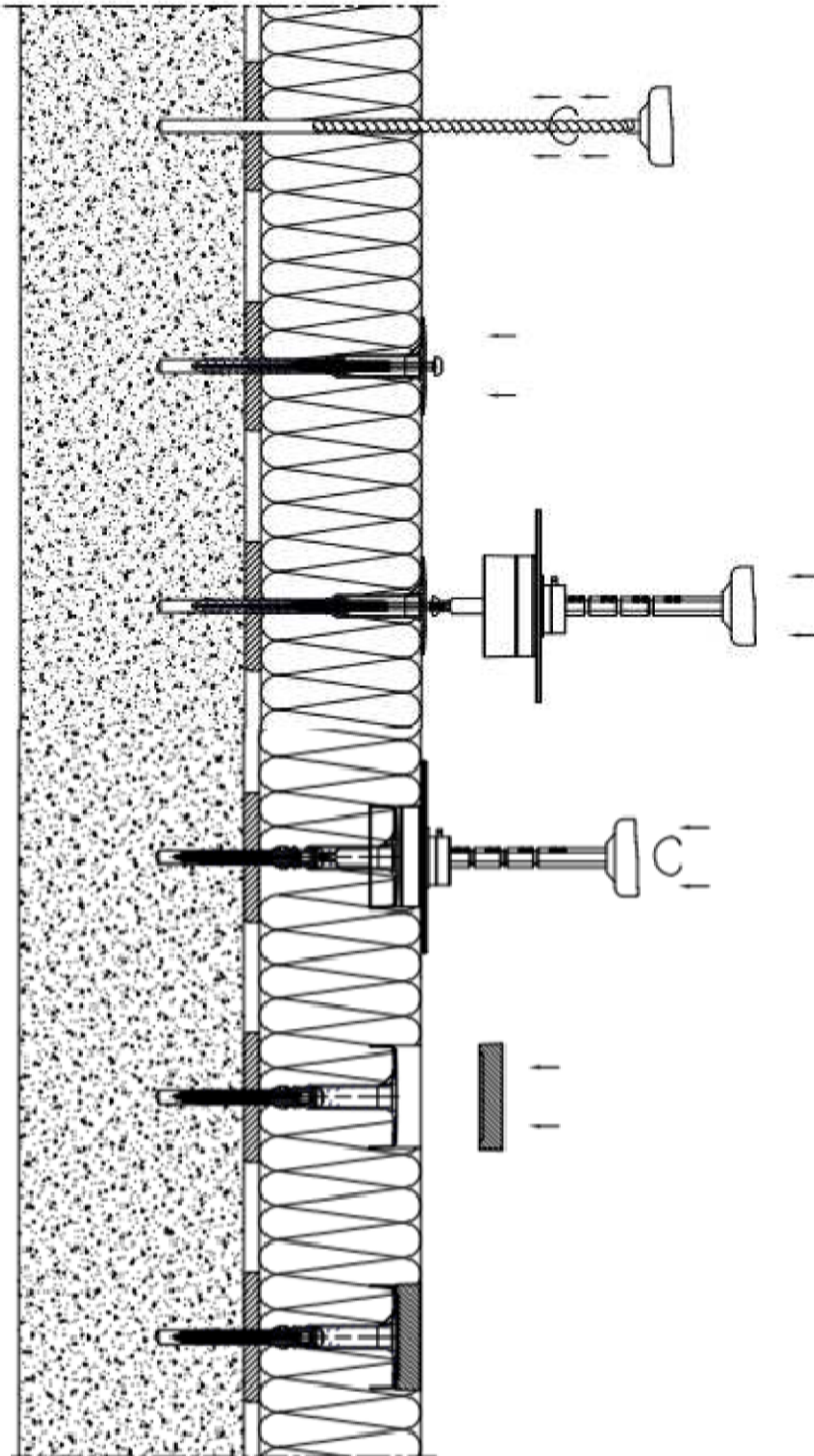

Drill the hole perpendicular to the substrate surface.
Clean the drill hole 3x.

Place the anchor into the drill hole. The bottom side of the plate must be flush with the ETICS.

Put the mounting tool into the drive unit.

Drill the specific screw with the mounting tool into the anchor.

Put the insulation cover into the hole from the insulation

Installed condition of Baumit S.

electronic copy of the eta by dibt: eta-17/0078

Baumit S and Baumit N

Intended use

Installation instructions Baumit S, countersunk into insulation

Annex B 4

Installation instructions: Baumit N / mounting flushed at the surface

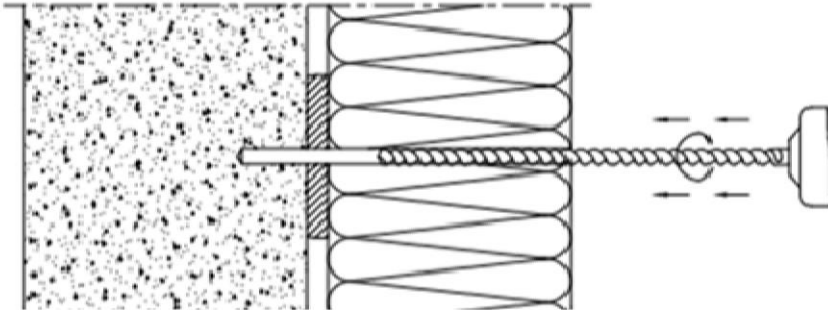

Drill the hole perpendicular to the substrate surface.
Clean the drill hole 3x.

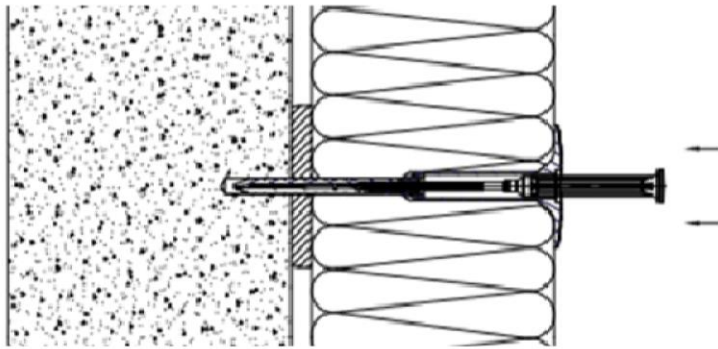

Place the anchor into the drill hole.
The bottom side of the plate must be flush with the ETICS.

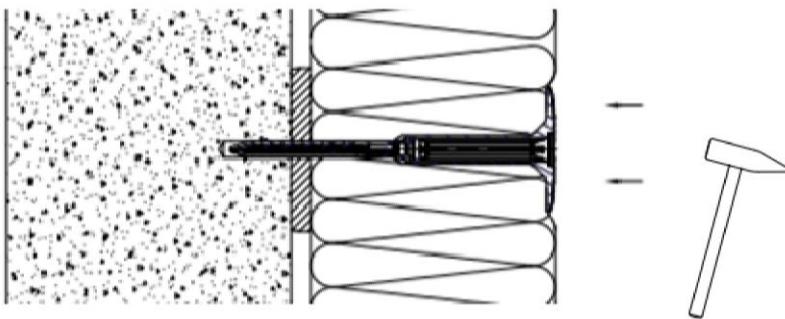

Drive in the specific nail with the hammer into the sleeve

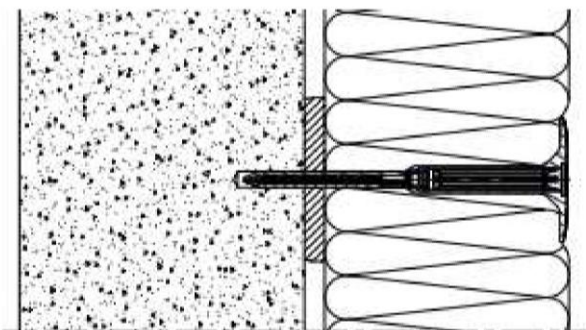

Installed condition of Baumit N.

electronic copy of the eta by dibt: eta-17/0078

Baumit S and Baumit N

Intended use

Installation instructions Baumit N, flushed at the surface

Annex B 5

Table C1: Characteristic resistance to tension loads N_{Rk} in concrete and masonry for a single anchor in kN

Anchor type					Baunit N	Baunit S
Base materials	Bulk density ρ [kg/dm ³]	minimum compressive strength f_b [N/mm ²]	General remarks	Drill method	N_{Rk} [kN]	N_{Rk} [kN]
Concrete C12/15 EN 206-1:2000				hammer	0,75	0,9
Concrete C20/25 – C50/60 EN 206-1:2000				hammer	1,2	1,5
Concrete C20/25 – C50/60 Thin members EN 206-1:2000 (thin members)			Thickness of the skin 100 mm > h ≥ 40 mm	hammer	1,2	1,5
Clay bricks, Mz e.g. according to EN 771-1:2011	≥ 1,8	36	Vertically perforation up to 15 %.	hammer	1,5	1,5
Sand-lime solid bricks, KS e.g. according to EN 771-2:2011	≥ 1,8	16	Vertically perforation up to 15 %.	hammer	1,5	1,5
Vertically perforated clay bricks, HLz e.g. according to EN 771-1:2011	≥ 1,4	16	Vertically perforation ≥ 15 % and ≤ 50 %. Outer web thickness ≥ 14 mm	rotary	0,9 ¹⁾	1,5 ¹⁾
Sand-lime perforated bricks, KSL e.g. according to EN 771-2:2011	≥ 1,4	12	Vertically perforation ≥ 15 %. Outer web thickness ≥ 20 mm	rotary	0,9 ²⁾	1,5 ²⁾
Lightweight concrete hollow blocks; Hbl e.g. according to EN 771-3:2011	≥ 0,9	4	Vertically perforation ≥ 15 %. Outer web thickness ≥ 30 mm	rotary	0,6 ³⁾	1,2 ³⁾
Lightweight aggregate concrete LAC 8 – LAC 25 e.g. according to EN 771-3:2011-07	≥ 1,2	8		hammer	0,6	0,75
Autoclaved aerated concrete AAC4 – AAC 7 e.g. according to EN 771-4:2011	≥ 0,55	4		rotary	0,75	0,75

¹⁾ The value applies only for outer web thickness ≥ 14 mm; otherwise the characteristic resistance shall be determined by job site pull-out tests.

²⁾ The value applies only for outer web thickness ≥ 20 mm; otherwise the characteristic resistance shall be determined by job site pull-out tests.

³⁾ The value applies only for outer web thickness ≥ 30 mm; otherwise the characteristic resistance shall be determined by job site pull-out tests.

Baunit S and Baunit N

Performances
Characteristic resistance

Annex C 1

Table C2: Point thermal transmittance according EOTA Technical Report TR 025:2007-06

anchor type	insulation thickness h_D [mm]	point thermal transmittance χ [W/K]
Baunit N,	60 – 260	0,001
Baunit S, countersunk	80 – 260	0,001
Baunit S, flushed	80 – 260	0,002

Table C3: Plate stiffness according EOTA Technical Report TR 026:2007-06

anchor type	diameter of the anchor plate [mm]	load resistance of the anchor plate [kN]	plate stiffness [kN/mm]
Baunit S+N	60	2,7	1,5

Table C4: Displacements

Base materials	Bulk density ρ [kg/dm ³]	Min. compressive strength f_b [N/mm ²]	Tension Load N [kN] Baunit N / S	Displacements $\delta_{(N)}$ [mm]	
				Baunit N	Baunit S
Concrete C20/25 – C50/60 (EN 206-1:2000)			0,4 / 0,5	0,4	0,4
Clay bricks, Mz (EN 771-1:2011)	≥ 1,8	36	0,5 / 0,5	0,3	0,3
Sand-lime solid bricks, KS (EN 771-2:2011)	≥ 1,8	16	0,5 / 0,5	0,4	0,4
Vertically perforated clay bricks, HLz (EN 771-1:2011)	≥ 1,4	16	0,3 / 0,5	0,2	0,4
Sand-lime perforated bricks, KSL (EN 771-2:2011)	≥ 1,4	12	0,3 / 0,5	0,3	0,3
Lightweight concrete hollow blocks, Hbl (EN 771-3:2011)	≥ 0,9	4	0,2 / 0,4	0,2	0,2
Lightweight aggregate concrete, LAC 8 – LAC 25 (EN 771-3:2011)	≥ 1,2	8	0,2 / 0,25	0,2	0,2
Autoclaved aerated concrete, AAC 4 – AAC 7 (EN 771-4:2011)	≥ 0,55	4	0,25 / 0,25	0,3	0,3

Baunit S und Baunit N

Performances

Point thermal transmittance, plate stiffness and displacements

Annex C 2