

Approval body for construction products
and types of construction

Bautechnisches Prüfamt

An institution established by the Federal and
Laender Governments



European Technical Assessment

ETA-05/0207
of 20 April 2018

English translation prepared by DIBt - Original version in German language

General Part

Technical Assessment Body issuing the
European Technical Assessment:

Deutsches Institut für Bautechnik

Trade name of the construction product

HALFEN Tension Rod System DETAN-S

Product family
to which the construction product belongs

Prefabricated Tension Rod System

Manufacturer

HALFEN GmbH
Liebigstraße 14
40764 Langenfeld
DEUTSCHLAND

Manufacturing plant

HALFEN GmbH
Otto-Brünner-Straße 3
06556 Artern
DEUTSCHLAND

This European Technical Assessment
contains

19 pages including 14 annexes which form an integral
part of this assessment

This European Technical Assessment is
issued in accordance with Regulation (EU)
No 305/2011, on the basis of

EAD 200032-00-0602

This version replaces

ETA-05/0207 issued on 19 April 2013

**European Technical Assessment
ETA-05/0207**

Page 2 of 19 | 20 April 2018

English translation prepared by DIBt

The European Technical Assessment is issued by the Technical Assessment Body in its official language. Translations of this European Technical Assessment in other languages shall fully correspond to the original issued document and shall be identified as such.

Communication of this European Technical Assessment, including transmission by electronic means, shall be in full. However, partial reproduction may only be made with the written consent of the issuing Technical Assessment Body. Any partial reproduction shall be identified as such.

This European Technical Assessment may be withdrawn by the issuing Technical Assessment Body, in particular pursuant to information by the Commission in accordance with Article 25(3) of Regulation (EU) No 305/2011.

Specific part

1 Technical description of the product

The construction product is a prefabricated tension rod system of different system sizes used as a kit. The tension rod system consists of steel bars (tension rods) with external threads which are connected to each other and to the corresponding structure by special connecting devices. The tension rods are connected to the corresponding structure by steel or steel cast fork end connectors or by steel spades with eye loops and internal thread. The fork end connectors and spades are connected by double shear pin connections to corresponding steel gusset plates or anchor discs. The tension rods are connected to each other by threaded steel sleeves (couplers, couplers with additional gusset plate, hexagon couplers and cross couplers), or by a fork end combination with a spade.

The tension rod system comprises tension rods, fork end connectors, spades, gusset plate, anchor discs, pins and threaded sleeves with metric ISO threads M 6 to M 95.

Drawings of the tension rod system and the components as well as the essential dimensions of the components are given in the Annexes to this ETA.

The dimensions, tolerances and materials of the components of the tension rod system not indicated in Annexes shall correspond to the respective values and information laid down in the technical documentation¹ to this European Technical Assessment.

2 Specification of the intended use in accordance with the applicable European Assessment Document

The tension rod system is intended for the use in structures with static or quasi-static loads in accordance with EN 1990:2002, where no verification of fatigue relating to EN 1993-1-9:2005 is necessary.

The intended use comprises for instance the suspension of roof structures or vertical glazing as well as bracings and truss structures.

The tension rod system is not subjected to systematic bending.

The fork end connectors may also be connected to compression rods. The compression rods themselves are not part of the ETA.

The performances given in Section 3 are only valid if the tension rod system is used in compliance with the specifications and conditions given in Annex 0 A and Annexes B1 to B10.

The verifications and assessment methods on which this European Technical Assessment is based lead to the assumption of a working life of the tension rod system of at least 25 years. The indications given on the working life cannot be interpreted as a guarantee given by the producer, but are to be regarded only as a means for choosing the right products in relation to the expected economically reasonable working life of the works.

¹ The technical documentation to this European Technical Assessment is deposited with Deutsches Institut für Bautechnik and, as far as relevant for the tasks of the approved bodies involved in the attestation of conformity procedure is handed over to the approved bodies.

English translation prepared by DIBt

3 Performance of the product and references to the methods used for its assessment

3.1 Mechanical resistance and stability (BWR 1)

3.1.1 Fork end connector, spade, gusset plate, anchor disc, pin, threaded sleeves

Essential characteristic	Performance
Geometry incl. tolerances	See Annexes B3 to B10
Dimensions incl. tolerances	
Thread incl. tolerances	
Material	See Annex B2
Load bearing capacity	See Annex A
Resistance to corrosion	

3.1.2 Tension rod

Essential characteristic	Performance
Nominal rod diameter	See Annexes B4
Thread incl. tolerances	
Yield strength	See Annex B2
Tensile strength	
Material	
Tension resistance	See Annex A
Compression force	
Resistance to corrosion	

3.2 Safety in case of fire (BWR 2)

Tension rod, fork end connector, spade, gusset plate, anchor disc, pin, threaded sleeves

Essential characteristic	Performance
Reaction to fire	Class A1 in accordance with EN 13501-1:2007+A1:2009

The components of the tension rod system satisfy the requirements for performance class A1 of the characteristic reaction to fire, in accordance with the provisions of EC decision 96/603/EC (as amended).

3.3 Safety and accessibility in use (BWR 4)

Same as BWR 1.

English translation prepared by DIBt

4 Assessment and verification of constancy of performance (AVCP) system applied, with reference to its legal base

In accordance with European Assessment Document EAD No. 200032-00-0602, the applicable European legal act is: 98/214/EC.

The system to be applied is: 2+

5 Technical details necessary for the implementation of the AVCP system, as provided for in the applicable EAD

Technical details necessary for the implementation of the AVCP system are laid down in the control plan deposited with Deutsches Institut für Bautechnik.

Issued in Berlin on 20 April 2018 by Deutsches Institut für Bautechnik

BD Dipl.-Ing. Andreas Kummerow
Head of Department

beglaubigt:
Bertram

Annex A

A.1 Assumptions concerning design

The design of the tension rod system is carried out under the following conditions:

The loading is static or quasi-static in accordance with EN 1990:2002 without need of verification of fatigue relating to EN 1993-1-9:2005.

The tension rod systems are not used, when constructions are susceptible to vibrations under wind loads or wind-induced cross vibrations of the entire construction appear.¹

Dimensions, material properties and screw-in lengths given in Annex B are observed.

The tension rod system is not subjected to systematic bending.

The verification concept stated in EN 1990:2002 as well as the design values of resistance stated below are used for design.

The rules given in EN 1090-2:2008 and EN ISO 12944:1998 are taken into account.

Design is carried out by the designer of the structure experienced in the field of steel structures.

Design tension resistance of the entire tension rod system

The design value $F_{t, RD}$ of the tension resistance of the entire tension rod system (tension rods, fork end connectors, spades, pins, threaded sleeves, gusset plates and anchor discs) is the value of the design tension resistance $F_{t, Rd, Tension\ Rod}$ of the tension rod.

The design values shall be determined according to EN 1993-1-1:2005 +AC:2009 and EN 1993-1-8:2005 +AC:2009 as follows:

$$F_{t, RD, Tension\ Rod} = \min \{ A \cdot f_{y, k} / \gamma_{M0}; 0.9 \cdot A_S \cdot f_{u, k} / \gamma_{M2} \}$$

A minimum cross section of the unthreaded part of the tension rod

A_S cross section of the threaded part of the tension rod

$f_{y, k}$ characteristic value of the yield strength of the tension rod according to $R_{p0,2}$ given in Annex B2

$f_{u, k}$ characteristic value of the tensile strength of the tension rod according to R_m given in Annex B2

$\gamma_{M0} = 1.00$ for steel

$\gamma_{M2} = 1.25$

The values given for the partial safety factors γ_{M0} and γ_{M2} are recommended minimum values. They should be used in cases where no values are given in national regulations of the Member State where the tension rod system is used or in the respective National Annex to Eurocode 3.

The design tension resistance $F_{t, RD}$ of the entire tension rod system determined with the recommended partial safety factors γ_{M0} and γ_{M2} is given in Annex B11.

¹ The national provisions of the Member State applicable for the location where the product is incorporated in the works shall be taken into account.

Design values of the compression force of tension rods and compression rods

The design value of the compression force $F_{c, RD}$ of tension rods or compression rods in combination with fork end connectors in accordance with Annex B3 is the minimum value of

- the design value of the compression force of struts in the cross-section of the thread and
- the design value of the compression force of struts calculated in accordance with EN 1993-1-1:2005.

The design value of the compression force of struts in the cross-section of the thread $F_{c, RD}$ should be determined as follows:

$$F_{c, RD} = \left[\frac{\gamma_{M2}}{A_S \cdot f_{u,c}} + \frac{\left(\frac{w - b}{2} + \frac{nRV}{50} \right) \cdot \gamma_{M0}}{W_{pl,S} \cdot f_{y,c}} \right]^{-1}$$

A_S tensile stress area of the thread

$W_{pl,S}$ plastic section modulus of the core cross section

$f_{y,c}$ characteristic value of the yield strength of the strut, where $f_{y,c} = R_{eH}$
characteristic value of the yield strength of the strut in accordance with product standard

$f_{u,c}$ characteristic value of the tension resistance of the strut, where $f_{u,c} = R_m$
characteristic value of the tensile strength of the strut in accordance with product standard

The dimensions of w , b , nRV are stated in Annex B3.

Recommended values for the partial safety factors γ_{M0} and γ_{M2} are:

$\gamma_{M0} = 1.00$ for steel

$\gamma_{M2} = 1.25$

The design value of the compression force of struts has to be determined in accordance with EN 1993-1-1:2005 considering the additional bending strength in consequence of one-sided contact of the gusset plates.

In addition EN 1993-1-1:2005 applies for verification against buckling.

A.2 Assumptions concerning Installation

The installation of the tension rod system is carried out under the following conditions:

The installation is only carried out in accordance with the manufacturer's instructions. The manufacturer hands over the assembly instructions to the assembler. From the assembly instructions it is followed that, prior to installation, all components of the tension rod system shall be checked for their perfect condition and that damaged components shall not be used.

The fork end connectors are not subjected to sudden or impact loads (for instance pins shall not be adjusted by hammer blows).

The minimum screw-in lengths are marked in an appropriate way. The compliance of the minimum screw-in lengths, given in Annex B, is checked by the assembler in accordance with the assembly instructions. The compliance of the screw-in lengths shall be attested with a written confirmation by a person responsible for the construction site.

The pins of the tension rod system are secured in their position with circlips.

All relevant components shall be checked continuously regarding corrosion damage after installation. The result of the checks shall be recorded.

The conformity of the installed tension rod system with the provisions of the ETA is attested by the executing assembler.

A.3 Indications to the manufacturer

The manufacturer shall ensure that the information on the specific conditions is given to those who are concerned. This information may be given by reproduction of the European Technical Assessment. In addition all essential installation data (e.g. minimum screw-in length in accordance with Annex B) shall be shown clearly on the package and/or on an enclosed instruction sheet, preferably using illustration(s).

The prefabricated tension rod system shall be packaged and delivered as a complete unit only (tension rods, fork end connectors and spades incl. pins, threaded sleeves).

Longer systems may be separated at the couplers for easier transportation.

The sizes 76 mm and above are delivered in individual parts. The assembly instructions must be observed to ensure correct assembly on site.

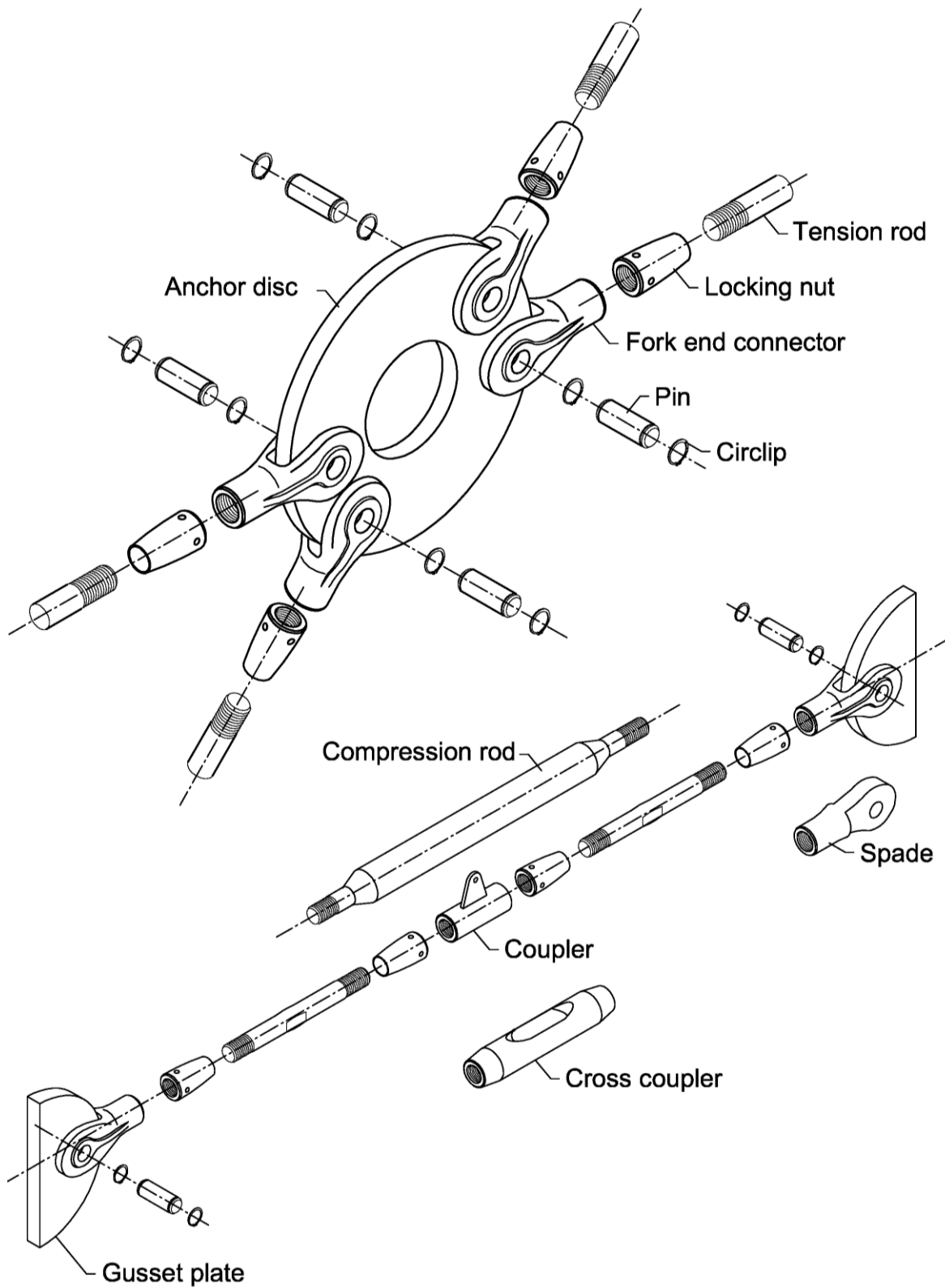

electronic copy of the eta by dibt: eta-05/0207

HALFEN Tension Rod System DETAN-S

Components

Annex B1

Component	System Size	Material	Specification	$R_{p0,2}$ [N/mm ²]	R_m [N/mm ²]
Fork end connector	M6 - M30	S355J2	EN 10025-2	360	500
	M16 - M95	G20 Mn5+QT	EN 10293	360	500
Tension rod	M6 - M12	S355J2	EN 10025-2	355	510
	M6 - M95	S460*	filed with DIBt	460*	625*
	M16 - M95	S470*		470*	700*
	M16 - M95	S520*		520*	720*
Pin	M6 - M60	C45+QT**	EN 10083-2	470	610**
	M64 - M95	C45+QT**		430	580**
	M6 - M60	C45+QT		470	700
	M64 - M95	C45+QT		430	700
	M6 - M60	S460N	EN 10025-3	470	700
	M64 - M95	S460N		430	700
Coupler	M6 - M95	S235JR	EN 10025-2	acc. to EN 10025-2	
	M6 - M95	S355J2		acc. to EN 10025-2	
	M6 - M95	S460*	filed with DIBt	460*	625*
	M6 - M95	S470*		470*	700*
	M6 - M95	S520*		520*	720*
Gusset plate	M6 - M12	S235JR***	EN 10025-2	acc. to EN 10025-2	
	M6 - M95	S355J2		acc. to EN 10025-2	
Anchor disc	M6 - M95	S355J2		acc. to EN 10025-2	
Spade	M6 - M95	S355J2	EN 10025-2	acc. to EN 10025-2	

* S460N or equivalent with special requirements

**with tension rod S460N oder S355J2

*** with tension rod S355J2

HALFEN Tension Rod System DETAN-S

Material properties of the components

Annex B2

Gusset plate grade S355 for
all sizes or S235 for M6 to M12

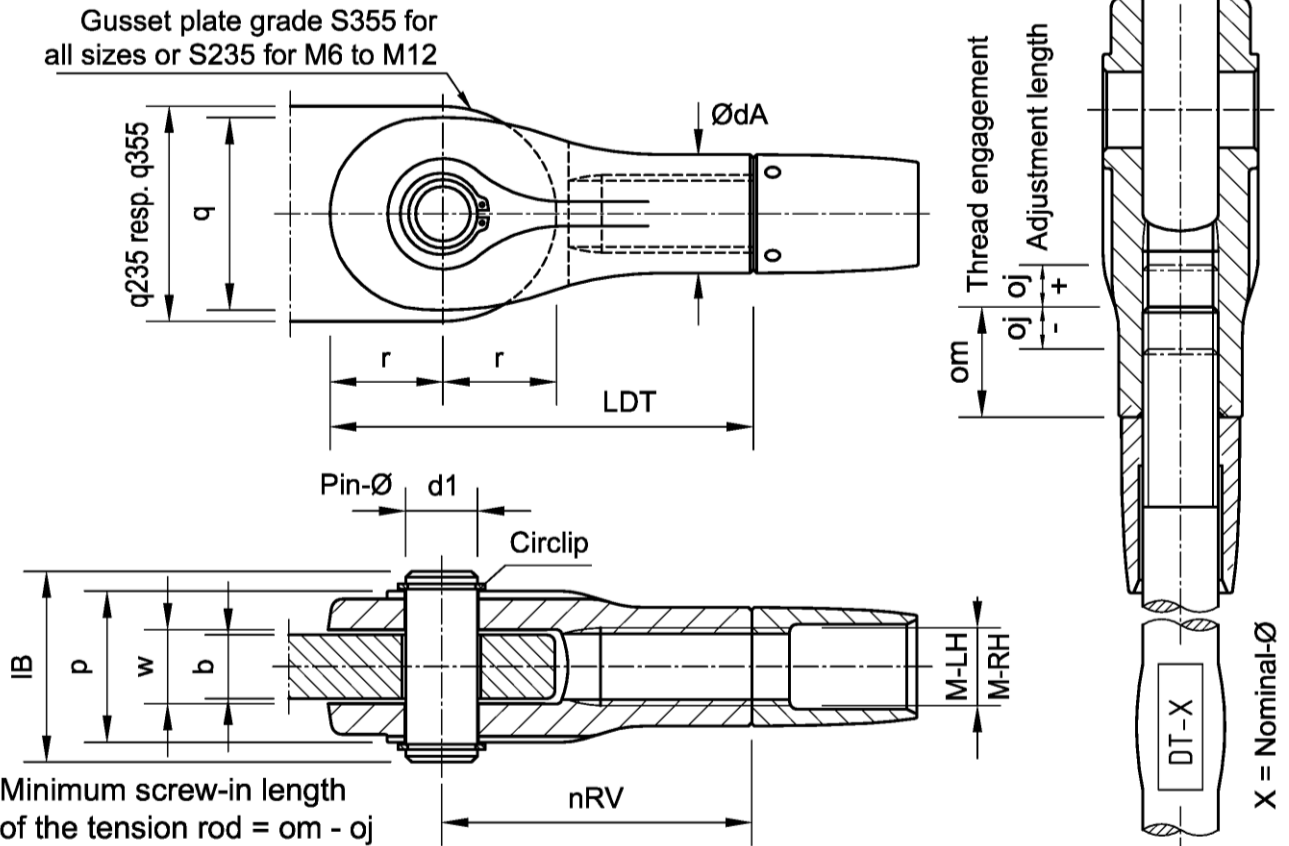

Minimum screw-in length
of the tension rod = $om - oj$

DT-S M-LH/ M-RH	dA	LDT	d1	p	q	q235	q355	r	w	nRV	b	om	± oj	IB	Material	
	[mm]														Fork end connector	Pin
M 6	9,6	42	6	12	16,7	18	16,7	9,3	5,6	32,7	5	10,5	4,5	18	S355J2	C45+QT or S460N
M 8	12,6	50	7	16	21,3	21	21,3	11,8	7,7	38,2	7	12,5	4,5	22		
M10	15,7	60	9	19,7	26,3	28	26,3	14,8	8,7	45,2	8	15	5	28		
M12	18,7	73	11	23,6	31,4	33	31,4	17,8	10,7	55,2	10	18,5	6,5	32		
M16	25	89	15	33	40,6		41	23,8	16	65,2	15	22,5	7,5	44		
M20	31	110	19	40	51		53	29,3	19	80,7	18	27	8	52	G20 Mn5+QT or S355J2	
M24	37	133	23	46,5	60,6		66	34,8	21	98,2	20	34	11	60		
M27	42	147	26	51	68,5		77	39,3	23	107,7	22	37,5	12,5	65		
M30	46,5	160	29	57	75,4		83	43,3	26	116,7	25	42,5	12,5	72		
M36	53,5	192	33	68	90		97	51,3	31	140,7	30	51	14	84		
M42	63	225	40	79	105,2		117	59,8	36	165,2	35	55	15	97	G20 Mn5+QT	
M48	74	265	46	90	118,5		134	70,3	41	194,7	40	62,5	17,5	111		
M52	80	285	48	98	125		143	76	46	209	45	70,5	20	119		
M56	86	305	52	107	136,5		152	82,5	51	222,5	50	77,5	22,5	130		
M60	91	335	56	116	146		162	88	56	247	55	85	25	139		
M64	116	380	65	128	176		185	107	57	273	55	95	30	157		
M76	134	460	75	146	196		222	129	67	331	65	115	39	180		
M85	152	520	85	166	216		248	149	77	371	75	130	45	202		
M95	173	580	95	189	236		281	159	88	421	85	155	60	229		

HALFEN Tension Rod System DETAN-S

Dimensions of the fork end connector and minimum dimensions of the gusset plates

Annex B3

English translation prepared by DIBt

Cut thread

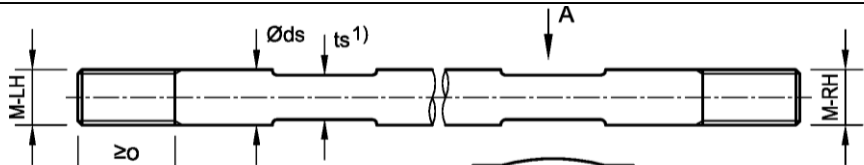

Rolled thread

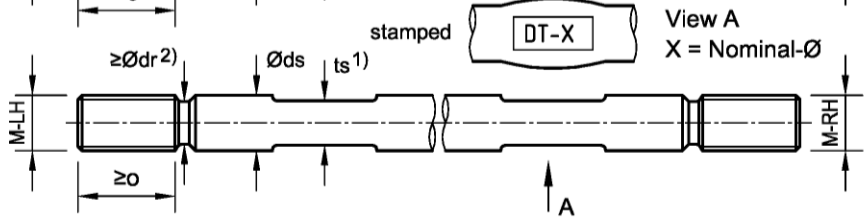

Cut thread
(Option M64-M95)

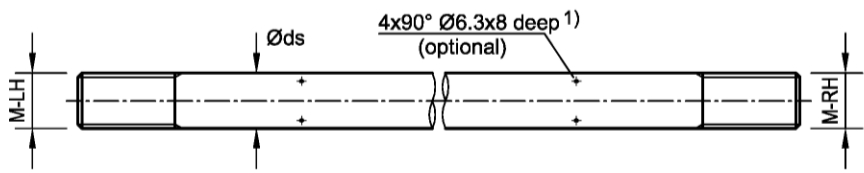

Rolled thread
(Option M64-M95)

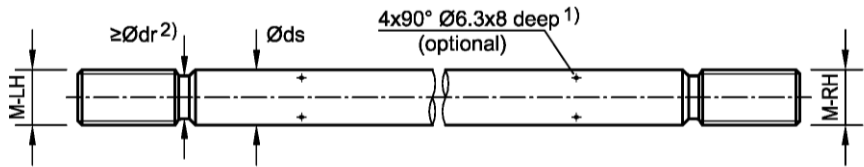

DT-S M-LH / M-RH	$\varnothing ds$	o	ts	$\varnothing dr$	Material	
	[mm]					
M 6 x 1,0	6	18	5	5,21	S355 or S460	1) alternatively with tooled spanner flats and rod marking 2) $\varnothing dr$ possible for the complete rod in case of rolled threads
M 8 x 1,25	8	21	6	7,04		
M10 x 1,5	10	25	8	8,86		
M12 x 1,75	12	31	10	10,68		
M16 x 2,0	16	38	14	14,50	S460, S470 or S520	
M20 x 2,5	20	45	18	18,16		
M24 x 3,0	24	57	21	21,80		
M27 x 3,0	27	64	24	24,80		
M30 x 3,5	30	70	27	27,46		
M36 x 4,0	36	83	32	33,12		
M42 x 4,5	42	91	36	38,78		
M48 x 5,0	48	104	41	44,43		
M52 x 5,0	52	116	46	48,43		
M56 x 5,5	56	128	50	52,09		
M60 x 5,5	60	140	55	56,09		
M64 x 6,0	64	157	55	59,74		
M76 x 6,0	76	192	65	71,74		
M85 x 6,0	85	218	75	80,74		
M95 x 6,0	95	263	85	90,72		

HALFEN Tension Rod System DETAN-S

Dimensions of the tension rods

Annex B4

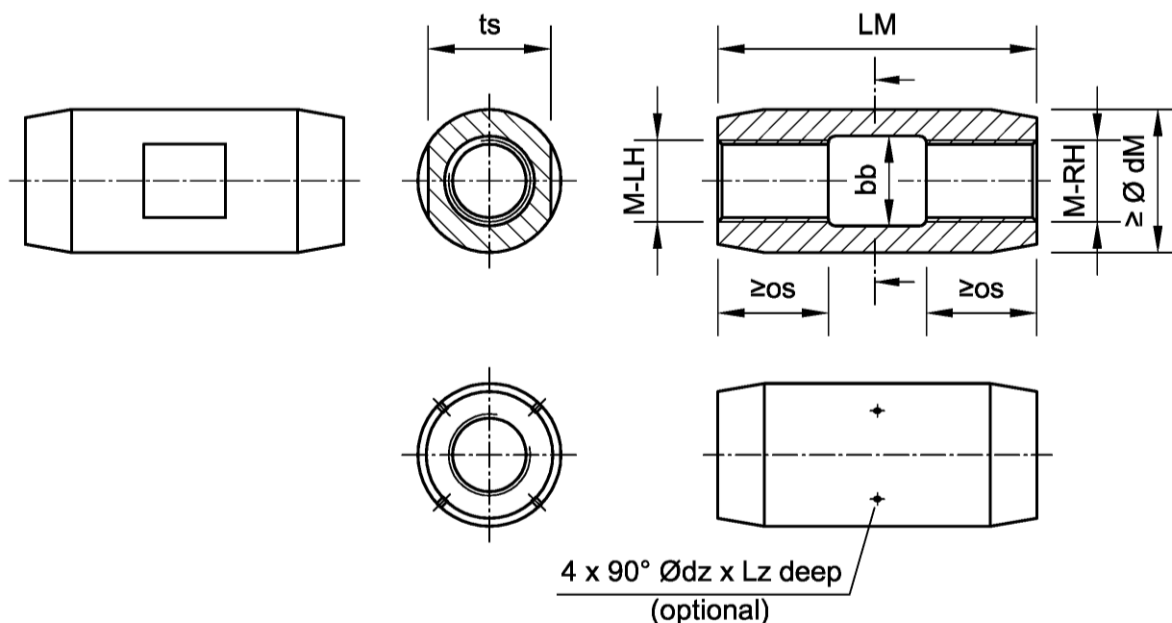

Minimum screw-in length of the tension rod = $o_m - o_j$ according to Annex B3

DT-S M-LH / M-RH	S235 min dM	≥ S355 min dM	LM	os	bb	ts	dz	Lz	Material
	[mm]								
M 6	12	12	34	9	6,3	10	–	–	S235, S355, S460, S470 or S520
M 8	15	15	40	11	8,4	13	–	–	
M10	20	20	40	13,5	10,5	17	–	–	
M12	22	22	50	16,5	12,6	19	–	–	
M16	29	27	62	31	16,8	24	–	–	
M20	36	35	78	39	21	30	–	–	
M24	44	42	94	47	25,2	36	–	–	
M27	49	47	104	39,5	28,4	41	–	–	
M30	54	52	120	47,5	31,5	46	–	–	
M36	65	60	140	55	37,8	55	–	–	
M42	76	75	158	64	44,1	65	–	–	
M48	87	85	180	75	50,4	75	–	–	
M52	95	90	195	80	54,6	80	–	–	
M56	108	95	210	87,5	58,8	85	–	–	
M60	120	100	245	105	63	90	–	–	
M64	130	130	270	110	67	115	8,3	12	
M76	150	150	328	139	79	130	8,3	12	
M85	170	170	370	155	88	150	10,3	12	
M95	190	190	450	200	98	160	10,3	12	

HALFEN Tension Rod System DETAN-S

Dimensions of the couplers

Annex B5

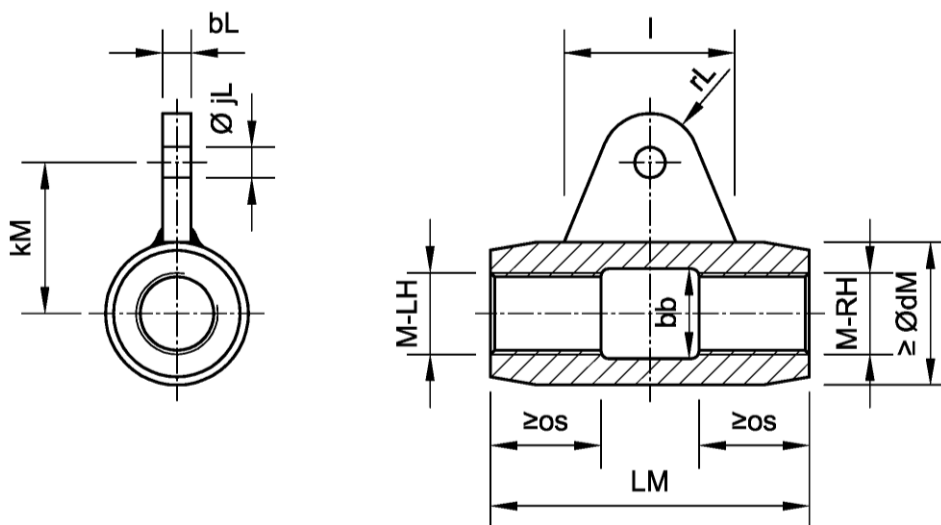

Minimum screw-in length of the tension rod = $o_m - o_j$ according to Annex B3

* /.. alternative dimensions for a M10 tension rod connection

DT-S M-LH / M-RH	S235 min dM	≥ S355 min dM	LM	os	bb	jL*	bL*	rL*	kM*	l*	Material
	[mm]										
M 6	12	12	34	9	6,3	6,5	5	9,3	21	20	S235, S355, S460, S470 or S520
M 8	15	15	40	11	8,4	6,5	5	9,3	21	27	
M10	20	20	40	13,5	10,5	6,5	5	9,3	23,5	27	
M12	22	22	50	16,5	12,6	6,5/9,5	5/8	9,3/11	27,5/28	32/32	
M16	29	27	62	31	16,8	6,5/9,5	5/8	9,3/11	33/31	36/32	
M20	36	35	78	39	21	7,5/9,5	7/8	12/15	37/44,5	41/54	
M24	44	42	94	47	25,2	7,5/9,5	7/8	12/15	44/48	45/54	
M27	49	47	104	39,5	28,4	9,5	8	15	50,5	54	
M30	54	52	120	47,5	31,5	9,5	8	15	57,5	58	
M36	65	60	140	55	37,8	9,5	8	15	72	67	
M42	76	75	158	64	44,1	9,5	8	15	86,5	75	
M48	87	85	180	75	50,4	11,5	10	18	98,5	87	
M52	95	90	195	80	54,6	11,5	10	18	111,5	96	
M56	108	95	210	87,5	58,8	11,5	10	18	124,5	104	
M60	120	100	245	105	63	11,5	10	18	137	112	
M64	130	130	270	110	67	11,5	10	18	130	110	
M76	150	150	328	139	79	11,5	10	18	140	110	
M85	170	170	370	155	88	15,5	15	24	150	110	
M95	190	190	450	200	98	15,5	15	24	157,5	110	

HALFEN Tension Rod System DETAN-S

Dimensions of the couplers with additional gusset plate

Annex B6

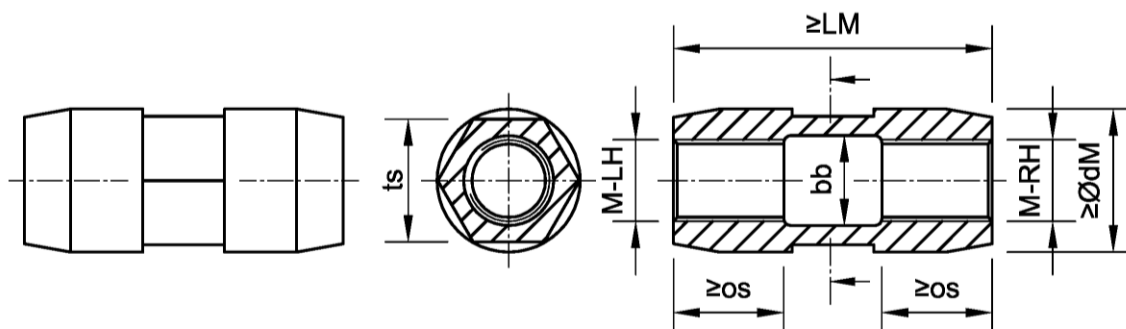

Minimum screw-in length of the tension rod = $o_m - o_j$ according to Annex B3

DT-S M-LH / M-RH	min dM	LM	os	bb	ts	dz	Lz	Material
M 6	12	34	9	6,3	10	-	-	S355, S460, S470 or S520
M 8	15	40	11	8,4	13	-	-	
M10	20	40	13,5	10,5	17	-	-	
M12	22	50	16,5	12,6	19	-	-	
M16	28	62	31	16,8	24	-	-	
M20	35	78	39	21	30	-	-	
M24	42	94	47	25,2	36	-	-	
M27	47	104	39,5	28,4	41	-	-	
M30	53	120	47,5	31,5	46	-	-	
M36	64	140	55	37,8	55	-	-	
M42	75	158	64	44,1	65	-	-	
M48	87	180	75	50,4	75	-	-	
M52	93	195	80	54,6	80	-	-	
M56	98	210	87,5	58,8	85	-	-	
M60	104	245	105	63	90	-	-	

HALFEN Tension Rod System DETAN-S

Dimensions of the hexagon couplers

Annex B7

English translation prepared by DIBt

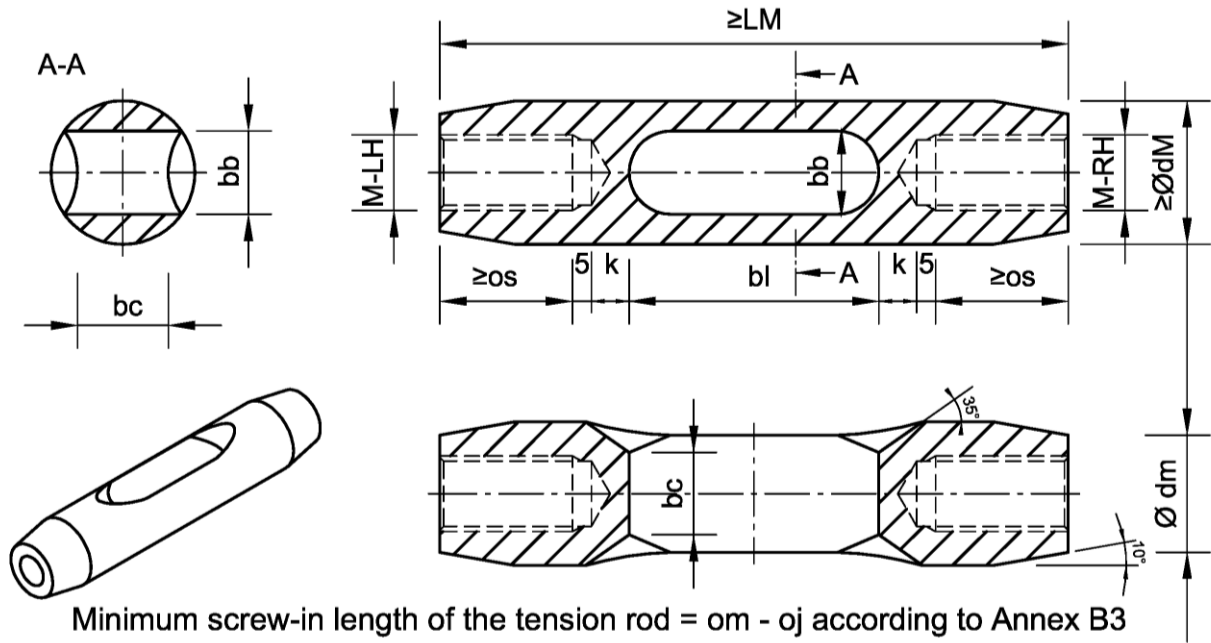

DT-S M-LH / M-RH	S355	≥S460	S520	LM	os	bb	bl	bc	dm	k
	min dM	min dM	min dM							
	[mm]									
M6	12	12	12	70	15	8	24	7,0	9,6	3
M8	16	15	15	85	17	10	33	10,9	12,6	4
M10	20	18	18	100	20	12	38	12,0	15,7	6
M12	24	22	22	120	25	14	46	15,1	18,7	7
M16	32	30	30	142	30	18	54	15,8	25	9
M20	39	36	36	166	35	22	66	19,4	31	10
M24	47	43	42	200	45	26	78	22,9	37	11
M27	53	49	48	222	50	29	87	25,5	42	12,5
M30	58	54	52	242	55	32	96	28,2	46,5	13
M36	70	64	62	284	65	38	114	33,4	53,5	15
M42	82	75	72	310	70	44	128	35,9	63	16
M48	93,5	85	83	348	80	50	142	38,4	74	18
M52	103,5	92	90	400	90,5	54	174	55,9	93	17,5
M56	113	101	98	440	100	60	191	60,5	98	19,5
M60	121	108	105	478	110	64	206	66,1	104	21
M64	129	115	112	524	125	68	220	71,0	116	22
M76	155	137	133	631	154	80	263	86,5	134	25
M85	175	154	150	710	175	90	294	96	152	28
M95	196	173	167	830	215	100	330	109	173	30

HALFEN Tension Rod System DETAN-S

Dimensions of the cross couplers

Annex B8

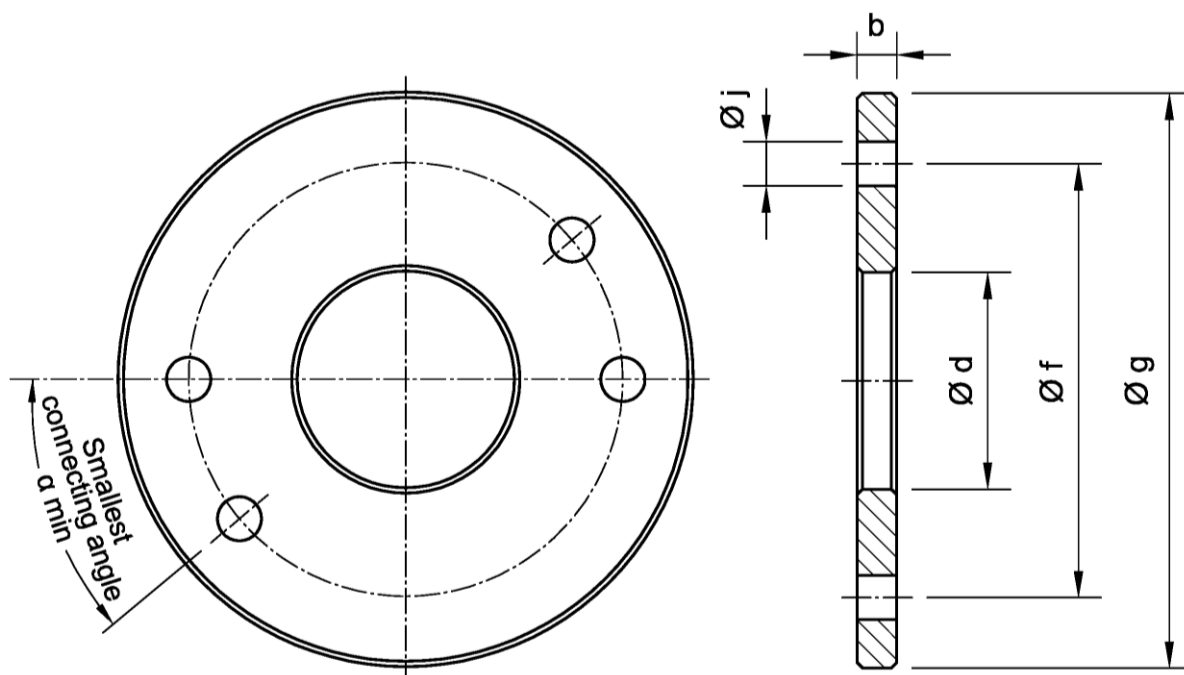

DT-S M-LH/ M-RH	$\alpha \min = 40^\circ$			$\alpha \min = 60^\circ$			$\alpha \min = 80^\circ$			Material		
	b	Ø j	Ø d	Ø f	Ø g	Ø d	Ø f	Ø g	Ø d		Ø f	Ø g
[mm]												
M 6	5	6,5	27	55	73	22	45	63	12	33	51	S355J2
M 8	7	7,5	37	75	99	25	55	79	15	42	66	
M10	8	9,5	46	90	120	33	70	100	20	55	85	
M12	10	11,5	56	110	146	35	80	116	22	65	101	
M16	15	15,5	70	140	186	50	110	156	28	85	131	
M20	18	19,5	94	180	238	57	130	188	35	105	163	
M24	20	23,5	106	210	280	63	150	220	40	125	195	
M27	22	26,5	120	240	318	72	170	248	45	140	218	
M30	25	29,5	132	260	346	82	190	276	52	155	241	
M36	30	33,5	156	310	412	92	220	322	62	185	287	
M42	35	41	182	360	480	100	250	370	72	215	335	
M48	40	47	212	420	558	125	300	438	82	250	388	
M52	45	49	228	450	600	130	320	470	90	270	420	
M56	50	53	248	490	652	145	350	512	100	295	457	
M60	55	57	262	520	692	150	370	542	105	315	487	
M64	55	66	270	596	810	160	426	640	100	351	565	
M76	65	76	325	702	960	180	502	760	120	422	680	
M85	75	86	360	777	1075	200	562	860	135	482	780	
M95	85	96	395	832	1150	225	612	930	150	522	840	

HALFEN Tension Rod System DETAN-S

Dimensions of the anchor discs K40, K60, K80

Annex B9

English translation prepared by DIBt

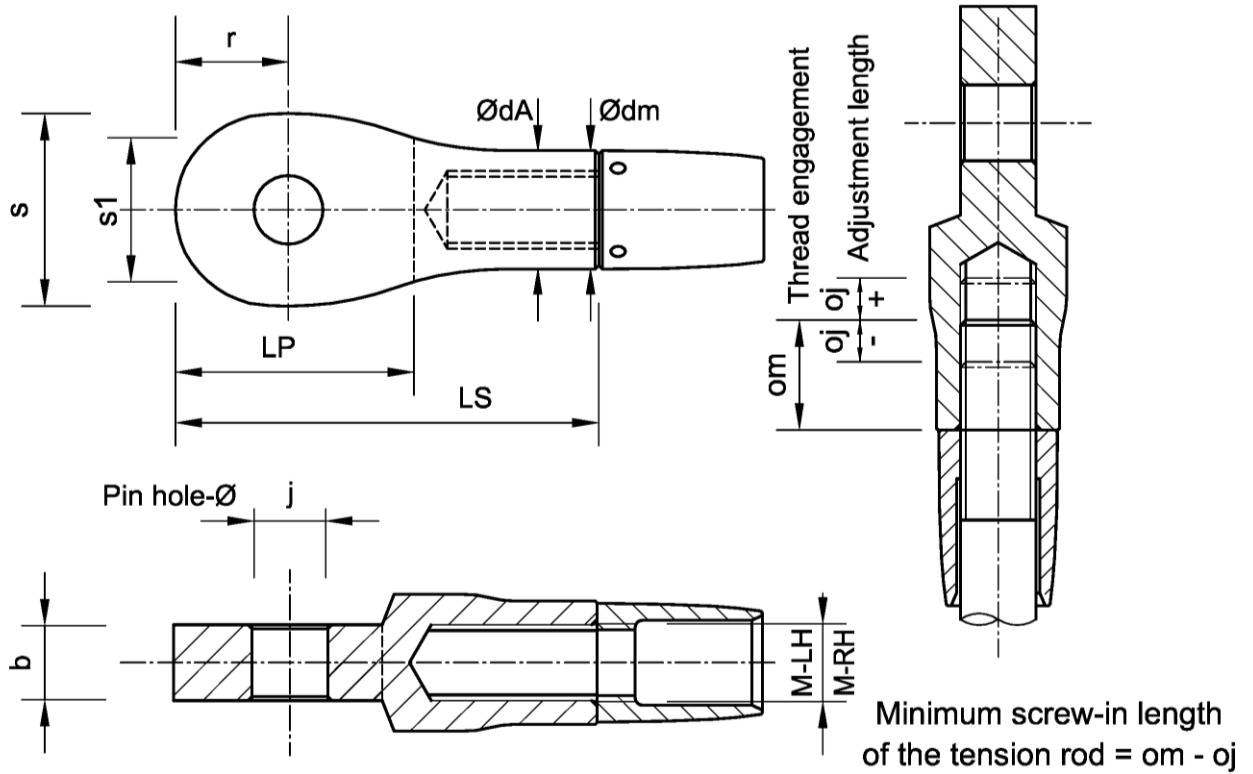

DT-S M-LH/ M-RH	Version A		Version B		(Version B with welded eye loop)									Material
	min dA	min s	min dA	min s	min s1	Ødm	om	± oj	LS	LP	r	b	Øj	
	[mm]													
M 6	9,6	16,7	9,6	16,7	9,6	9,6	10,5	4,5	42	19	9,3	5	6,5	S355, S460, S470 or S520
M 8	12,6	21,3	12,6	21,3	12,6	12,6	12,5	4,5	50	24	11,8	7	7,5	
M10	15,7	28	15,7	26,3	15,7	15,7	15	5	60	30	14,8	8	9,5	
M12	18,7	33	18,7	31,4	19,9	18,7	18,5	6,5	73	37	17,8	10	11,5	
M16	25	43	25	41	28,0	25	22,5	7,5	89	48	23,8	15	15,5	
M20	30,7	56	30,7	53	32,9	30,7	27	8	110	59	29,3	18	19,5	
M24	37	69	37	66	42,1	37	34	11	133	73	34,8	20	23,5	
M27	42	79	42	76	50,0	42	37,5	12,5	147	82	39,3	22	26,5	
M30	46,5	87	46,5	83	51,0	46,5	42,5	12,5	160	88	43,3	25	29,5	
M36	55,4	104	53,8	97	58,5	53,5	51	14	192	106	51,3	30	33,5	
M42	64,8	126	63	117	70,9	63	55	15	225	129	59,8	35	41	
M48	74,2	144	74	134	79,2	74	62,5	17,5	265	150	70,3	40	47	
M52	81,6	153	80	143	86,0	80	70,5	20	285	162	76	45	49	
M56	87,8	163	87	152	90,8	86	77,5	22,5	305	175	82,5	50	53	
M60	94,5	174	93,5	162	102	91	85	25	335	185	88	55	57	
M64	116	200	116	185	116	116	95	30	380	223	107	55	66	
M76	134	240	134	222	140	134	115	39	460	269	129	65	76	
M85	152	270	152	248	157	152	130	45	520	306	149	75	86	
M95	173	300	173	281	178	173	155	60	580	326	159	85	96	

HALFEN Tension Rod System DETAN-S

Dimensions of the spade

Annex B10

System Size	design tension resistance of the tension rod system $F_{t,Rd}$ [kN]			
	S520	S470	S460	S355
M6	-	-	9,05	7,39
M8	-	-	16,47	13,44
M10	-	-	26,10	21,30
M12	-	-	37,92	30,94
M16	81,22	78,96	70,50	-
M20	126,9	123,4	110,2	-
M24	182,7	177,7	158,6	-
M27	238,1	231,5	206,7	-
M30	290,6	282,5	252,3	-
M36	423,4	411,6	367,5	-
M42	581,1	564,9	504,4	-
M48	763,7	742,5	662,9	-
M52	911,3	885,9	791,0	-
M56	1052,4	1023,1	913,5	-
M60	1224,5	1190,5	1062,9	-
M64	1387,2	1348,7	1204,2	-
M76	2016,2	1960,2	1750,2	-
M85	2564,9	2493,7	2226,5	-
M95	3252,0	3161,6	2822,9	-

($\gamma_{M0}=1,0$ und $\gamma_{M2}=1,25$ note Annex A)

HALFEN Tension Rod System DETAN-S

design tensions resistance of the entire tension rod system

Annex B11