

Approval body for construction products
and types of construction

Bautechnisches Prüfamt

An institution established by the Federal and
Laender Governments



European Technical Assessment

ETA-06/0155
of 9 May 2018

English translation prepared by DIBt - Original version in German language

General Part

Technical Assessment Body issuing the
European Technical Assessment:

Deutsches Institut für Bautechnik

Trade name of the construction product

MKT Wedge anchor B A4 and B HCR

Product family
to which the construction product belongs

Torque-controlled expansion anchor made of stainless
steel of sizes 30 M6 and 40 M6 for multiple use for
non-structural applications in concrete

Manufacturer

MKT
Metall-Kunststoff-Technik GmbH & Co. KG
Auf dem Immel 2
67685 Weilerbach

Manufacturing plant

MKT
Metall-Kunststoff-Technik GmbH & Co. KG
Auf dem Immel 2
67685 Weilerbach

This European Technical Assessment
contains

10 pages including 3 annexes which form an integral part
of this assessment

This European Technical Assessment is
issued in accordance with Regulation (EU)
No 305/2011, on the basis of

ETAG 001 Part 6: "Anchors for multiple use for
non-structural applications",
used as EAD according to Article 66 Paragraph 3 of
Regulation (EU) No 305/2011

This version replaces

ETA-06/0155 issued on 17 May 2013

The European Technical Assessment is issued by the Technical Assessment Body in its official language. Translations of this European Technical Assessment in other languages shall fully correspond to the original issued document and shall be identified as such.

Communication of this European Technical Assessment, including transmission by electronic means, shall be in full. However, partial reproduction may only be made with the written consent of the issuing Technical Assessment Body. Any partial reproduction shall be identified as such.

This European Technical Assessment may be withdrawn by the issuing Technical Assessment Body, in particular pursuant to information by the Commission in accordance with Article 25(3) of Regulation (EU) No 305/2011.

Specific Part

1 Technical description of the product

The MKT Wedge Anchor B A4 and B HCR of sizes 30 M6 and 40 M6 is an anchor made of stainless steel and high corrosion resistant steel which is placed into a drilled hole and anchored by torque-controlled expansion.

The product description is given in Annex A.

2 Specification of the intended use in accordance with the applicable European Assessment Document

The performances given in Section 3 are only valid if the anchor is used in compliance with the specifications and conditions given in Annex B.

The verifications and assessment methods on which this European Technical Assessment is based lead to the assumption of a working life of the anchor of at least 50 years. The indications given on the working life cannot be interpreted as a guarantee given by the producer, but are to be regarded only as a means for choosing the right products in relation to the expected economically reasonable working life of the works.

3 Performance of the product and references to the methods used for its assessment

3.1 Mechanical resistance and stability (BWR 1)

The essential characteristics regarding mechanical resistance and stability are included under the Basic Works Requirement Safety in use.

3.2 Safety in case of fire (BWR 2)

Essential characteristic	Performance
Reaction to fire	Anchorage satisfy requirements for Class A1
Resistance to fire	See Annex C 1

3.3 Safety in use (BWR 4)

Essential characteristic	Performance
Characteristic resistance for all load directions	See Annex C 1

4 Assessment and verification of constancy of performance (AVCP) system applied, with reference to its legal base

In accordance with guideline for European technical approval ETAG 001, January 2011, used as European Assessment Document (EAD) according to Article 66 Paragraph 3 of Regulation (EU) No 305/2011, the applicable European legal act is: [97/161/EC].

The system to be applied is: 2+

5 Technical details necessary for the implementation of the AVCP system, as provided for in the applicable European Assessment Document

Technical details necessary for the implementation of the AVCP system are laid down in the control plan deposited with Deutsches Institut für Bautechnik.

Issued in Berlin on 9 May 2018 by Deutsches Institut für Bautechnik

BD Dipl.-Ing. Andreas Kummerow
Head of Department

beglaubigt:
Lange

For multiple use for non-structural applications
according to ETAG 001 Part 6 Annex 1

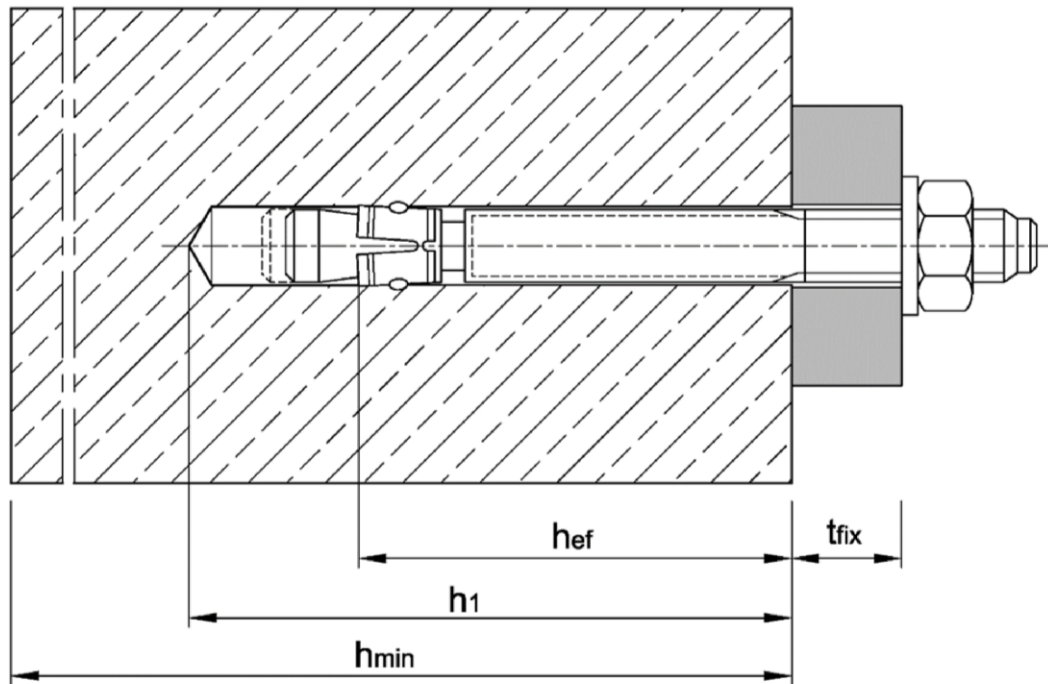
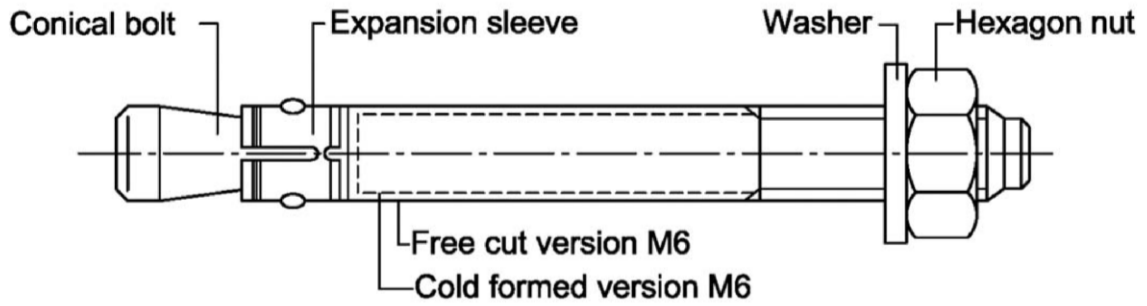

Wedge Anchor B A4 and B HCR

Product description
Intended use

Annex A1

Marking: e.g. \diamond 10/20 A4

- \diamond Identifying mark of manufacturing plant
- 10 Maximum thickness of fixture for 40 M6
- 20 Maximum thickness of fixture for 30 M6
- A4 Stainless steel A4
- HCR High corrosion resistant steel

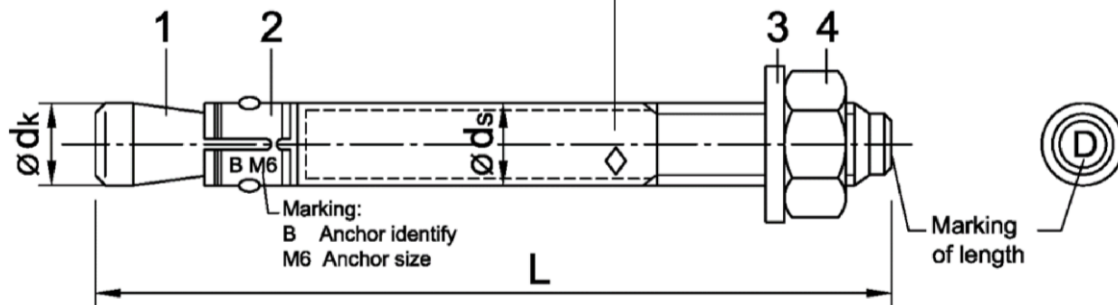

Marking of length	A	B	C	D	E	F	G	H	I	J
Length of anchor min \geq	38,1	50,8	63,5	76,2	88,9	101,6	114,3	127,0	139,7	152,4
Length of anchor max $<$	50,8	63,5	76,2	88,9	101,6	114,3	127,0	139,7	152,4	165,1

Marking of length	K	L	M	N	O	P	Q	R	S	T	U
Length of anchor min \geq	165,1	177,8	190,5	203,2	215,9	228,6	241,3	254,0	279,4	304,8	330,2
Length of anchor max $<$	177,8	190,5	203,2	215,9	228,6	241,3	254,0	279,4	304,8	330,2	355,6

Dimensions in mm

Table A1: Dimensions in mm

Anchor size	$\varnothing d_k$	$\varnothing d_s$	Anchor length L	Wrench size SW
30 M6	6	6 / 5,3 ¹⁾	$t_{fix} + 47,4$	10
40 M6	6	6 / 5,3 ¹⁾	$t_{fix} + 57,4$	10

¹⁾ cold formed version

Table A2: Designations and Materials

Part	Designation	Stainless steel A4	High corrosion resistant steel (HCR)
1	Conical bolt	Stainless steel 1.4401, 1.4404, 1.4571, 1.4578, 1.4362, EN 10088:2014, coated	High corrosion resistant steel 1.4529, 1.4565, EN 10088:2014, coated
2	Expansion sleeve	Stainless steel 1.4401, 1.4404, 1.4571, 1.4362, EN 10088:2014	
3	Washer	Stainless steel EN 10088:2014	High corrosion resistant steel 1.4529, 1.4565, EN 10088:2014
4	Hexagon nut	EN ISO 3506-2:2009, A4-70, stainless steel, EN 10088:2014, coated	EN ISO 3506-2:2009, strength class 70, high corrosion resistant steel 1.4529, 1.4565, EN 10088:2014, coated

Wedge Anchor B A4 and B HCR

Product description
Marking, dimensions and material

Annex A2

Specifications of intended use

Multiple use for non-structural applications, according to ETAG 001 Part 6, Edition August 2010

Anchorage subject to:

- static and quasi-static loads
- fire exposure

Base materials:

- Reinforced or unreinforced normal weight concrete according to EN 206-1:2000
- Strength classes C20/25 to C50/60 according to EN 206-1:2000
- Cracked and uncracked concrete

Use conditions (Environmental conditions):

- Structures subject to dry internal conditions (stainless steel or high corrosion resistant steel).
- Structures subject to external atmospheric exposure (including industrial and marine environment) and to permanently damp internal condition, if no particular aggressive conditions exist (stainless steel or high corrosion resistant steel).
- Structures subject to external atmospheric exposure and to permanently damp internal condition, if other particular aggressive conditions (high corrosion resistant steel).

Note: Particular aggressive conditions are e.g. permanent, alternating immersion in seawater or the splash zone of seawater, chloride atmosphere of indoor pools or atmosphere with extreme chemical pollution (e.g. in desulphurization plants or road tunnels where de-icing materials are used.)

Design:

- Anchorages are designed under the responsibility of an engineer experienced in anchorages and concrete work.
- Verifiable calculation notes and drawings are prepared taking account of the loads to be anchored. The position of the anchor is indicated on the design drawings (e.g. position of the anchor relative to reinforcement or to supports, etc.).
- Anchorages under static or quasi-static actions for multiple use in non-structural applications are designed in accordance with:
 - ETAG 001, Annex C, design method B, Edition August 2010 or
 - CEN/TS 1992-4: 2009, design method B
- Anchorages under fire exposure are designed in accordance with:
 - ETAG 001, Annex C, design method B, Edition August 2010 and EOTA Technical Report TR 020, Edition May 2004 or
 - CEN/TS 1992-4: 2009, Annex D
 - It must be ensured that local spalling of the concrete cover does not occur.

Installation:

- Anchor installation carried out by appropriately qualified personnel and under the supervision of the person responsible for technical matters of the site,
- Anchor installation in accordance with the manufacturer's specifications and drawings and using the appropriate tools,
- Positioning of the drill holes without damaging the reinforcement.
- Anchor installation such that the effective anchorage depth is complied with. This compliance is ensured, if the thickness of fixture is not greater than the maximum thickness of fixture marked on the anchor in accordance with Annex A2 and the hexagon nut is placed at the end of the conical bolt as delivered by the manufacturer.

Wedge Anchor B A4 and B HCR

Intended use
Specifications

Annex B1

Table B1: Installation parameters

Anchor size		30 M6	40 M6
Nominal drill hole diameter	$d_0 =$ [mm]	6	6
Cutting diameter of drill bit	$d_{cut} \leq$ [mm]	6,40	6,40
Tightening torque	$T_{inst} =$ [Nm]	8	8
Drill hole depth	$h_1 \geq$ [mm]	45	55
Effective embedment depth	$h_{ef} \geq$ [mm]	30	40
Minimum thickness of concrete member	h_{min} [mm]	80	80
Minimum spacing	s_{min} [mm]	50	50
Minimum edge distance	c_{min} [mm]	50	50
Diameter of clearance hole in the fixture	$d_f \leq$ [mm]	7	7

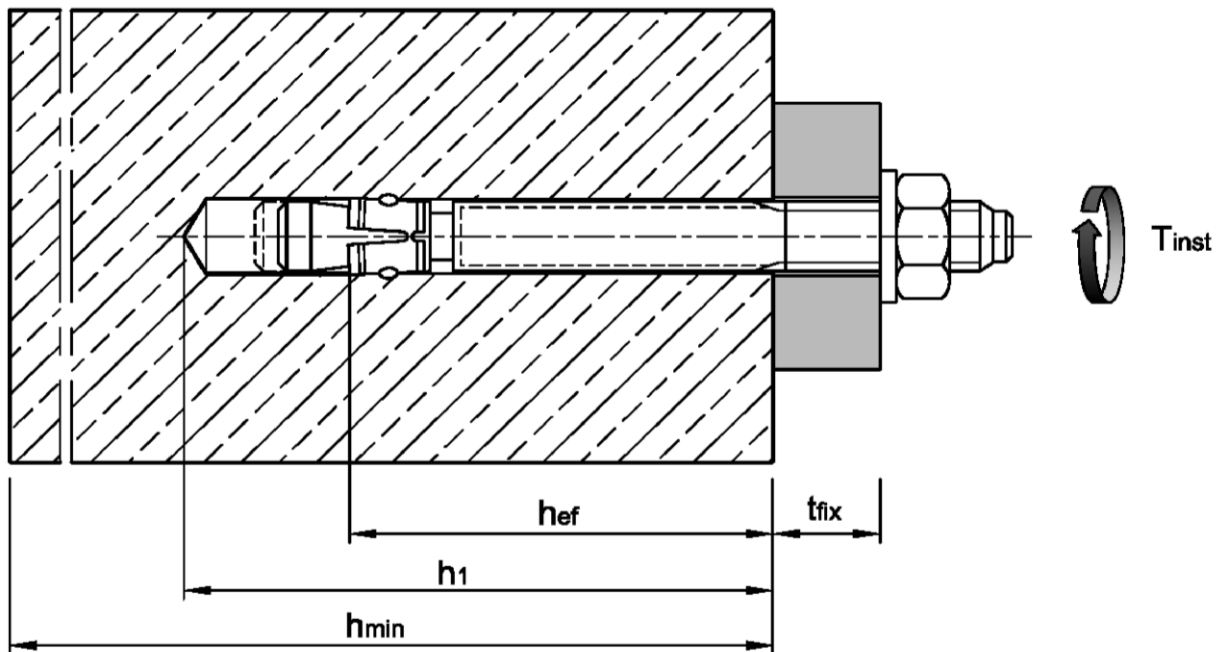

Wedge Anchor B A4 and B HCR

Intended use
Installation parameters

Annex B2

Installation instructions

	<p>Drill hole perpendicular to concrete surface, positioning of the drill holes without damaging the reinforcement. In case of aborted hole: new drilling at a minimum distance away of twice the depth of the aborted hole or smaller distance if the aborted drill hole is filled with high strength mortar and if under shear or oblique tension load it is not in the direction of load application.</p>
	<p>Blow out dust.</p>
	<p>Check position of nut.</p>
	<p>Drive in anchor. Observe effective anchorage depth. This is ensured, if the thickness of fixture is not greater than the maximum thickness of fixture marked on the anchor (acc. to Annex A2).</p>
	<p>Apply installation torque T_{inst} by using torque wrench.</p>

Wedge Anchor B A4 and B HCR

Intended use
Installation Instructions

Annex B3

Table C1: Characteristic values of resistance, design method B

Anchor size			30 M6	40 M6
All load directions				
Characteristic resistance in C20/25 to C50/60	F_{Rk}^0	[kN]	5	6
Partial factor	γ_M	[-]	2,16	1,8
Design resistance in C20/25 to C50/60	F_{Rd}^0	[kN]	2,3	3,3
Spacing	s_{cr}	[mm]	260	370
Edge distance	c_{cr}	[mm]	130	185
Shear load with lever arm				
Characteristic bending resistance	$M_{Rk,s}^0$ ¹⁾	[Nm]	10	10
Partial factor	γ_{Ms}	[-]	1,25	1,25

¹⁾ Characteristic bending resistance $M_{Rk,s}^0$ for equation (5.5) in ETAG 001, Annex C respectively equation (14) CEN/TS 1992-4-4

Table C2: Characteristic values under fire exposure in concrete C20/25 to C50/60, design method B

Anchor size			30 M6 40 M6
Fire resistance class	In any load direction		
R 30	Characteristic resistance	$F_{Rk,fi30}^0$	[kN] 0,6
	Characteristic bending resistance	$M_{Rk,s,fi30}^0$	[Nm] 0,5
R 60	Characteristic resistance	$F_{Rk,fi60}^0$	[kN] 0,5
	Characteristic bending resistance	$M_{Rk,s,fi60}^0$	[Nm] 0,4
R 90	Characteristic resistance	$F_{Rk,fi90}^0$	[kN] 0,3
	Characteristic bending resistance	$M_{Rk,s,fi90}^0$	[Nm] 0,3
R 120	Characteristic resistance	$F_{Rk,fi120}^0$	[kN] 0,3
	Characteristic bending resistance	$M_{Rk,s,fi120}^0$	[Nm] 0,2
R 30 to R 120	Spacing	$s_{cr,fi}$	[mm] 4 h_{ef}
		s_{min}	[mm] 50
	Edge distance	$c_{cr,fi}$	[mm] 2 h_{ef}
		c_{min}	[mm] 50
	Partial factor	$\gamma_{M,fi}$	[-] 1,0
If the fire attacks from more than one side, the edge distance shall be ≥ 300 mm.			

Wedge Anchor B A4 and B HCR

Performance
Characteristic resistances under normal ambient temperature and fire exposure, design method B

Annex C1