

Approval body for construction products
and types of construction

Bautechnisches Prüfamt

An institution established by the Federal and
Laender Governments



European Technical Assessment

ETA-06/0221
of 30 April 2018

English translation prepared by DIBt - Original version in German language

General Part

Technical Assessment Body issuing the
European Technical Assessment:

Deutsches Institut für Bautechnik

Trade name of the construction product

villerit Inno Therm EPS

Product family
to which the construction product belongs

Product area code: 4
External Thermal Insulation Composite system with
rendering on expanded polystyrene for the use as
external insulation to walls of buildings

Manufacturer

villerit-Putzsysteme
Unterer Dammweg 26
78050 Villingen-Schwenningen

Manufacturing plant

villerit-Putzsysteme
Unterer Dammweg 26
78050 Villingen-Schwenningen

This European Technical Assessment
contains

21 pages including 4 annexes which form an integral part
of this assessment

Annex 5 Control Plan contains confidential information
and is not included in the European Technical
Assessment when that assessment is publicly available

This European Technical Assessment is
issued in accordance with Regulation (EU)
No 305/2011, on the basis of

ETAG 004, edition 2000, amended 2013,
used as EAD according to Article 66 Paragraph 3 of
Regulation (EU) No 305/2011.

This version replaces

ETA-06/0221 issued on 19 October 2017

**European Technical Assessment
ETA-06/0221**

Page 2 of 21 | 30 April 2018

English translation prepared by DIBt

The European Technical Assessment is issued by the Technical Assessment Body in its official language. Translations of this European Technical Assessment in other languages shall fully correspond to the original issued document and shall be identified as such.

Communication of this European Technical Assessment, including transmission by electronic means, shall be in full. However, partial reproduction may only be made with the written consent of the issuing Technical Assessment Body. Any partial reproduction shall be identified as such.

This European Technical Assessment may be withdrawn by the issuing Technical Assessment Body, in particular pursuant to information by the Commission in accordance with Article 25(3) of Regulation (EU) No 305/2011.

Specific Part

1 Technical description of the product

1.1 Definition of the kit

This product is an External Thermal Insulation Composite System (ETICS) with rendering - a kit comprising components which are factory-produced by the manufacturer or component suppliers. It's made up on site from these. The ETICS manufacturer is ultimately responsible for all components of the ETICS specified in this ETA.

The ETICS kit comprises a prefabricated insulation product of expanded polystyrene (EPS) to be bonded and if it necessary additional mechanically fixed onto a wall. The methods of fixing and the relevant components are specified in the table below.

The insulation product is faced with a rendering system consisting of one base coat and finishing coat (site applied), in which the base coat contains reinforcement. The rendering is applied directly to the insulating panels, without any air gap or disconnecting layer.

The ETICS may include special fittings (e.g. base profiles, corner profiles ...) for connection to adjacent building elements (apertures, corners, parapets ...). Assessment and performance of these components is not addressed in this ETA, however the ETICS manufacturer is responsible for adequate compatibility and performance within the ETICS when the components are delivered as a part of the kit.

1.2 Composition of the ETICS

	Components National application documents shall be taken into account	Coverage [kg/m ²]	Thickness [mm]
Insulation material with associated method of fixing	Bonded ETICS: <ul style="list-style-type: none"> • Insulation product (see annex 1 for product characteristics) factory-prefabricated expanded polystyrene (EPS) <ul style="list-style-type: none"> - standard EPS • Adhesives (cement based powder requiring addition of about 25 % of water/ minimum bonded surface 40 %) <ul style="list-style-type: none"> - villerit Baukleber VWS 850 grau - villerit Baukleber VWS 850 weiß - villerit InnoTherm - villerit activDRY Klebe- und Armierungsmörtel - villerit KA-Basic Klebe- und Armierungsmörtel 	<p style="text-align: center;">-</p> <div style="display: flex; align-items: center;"> <div style="font-size: 2em; margin-right: 5px;">}</div> <div style="margin-right: 5px;">5.7 - 7.0</div> <div style="margin-right: 5px;">(prepared)</div> <div style="margin-left: 20px;">-</div> </div> <div style="display: flex; align-items: center;"> <div style="font-size: 2em; margin-right: 5px;">}</div> <div style="margin-right: 5px;">3.5 – 5.5</div> <div style="margin-right: 5px;">(prepared)</div> <div style="margin-left: 20px;">-</div> </div> <div style="display: flex; align-items: center;"> <div style="margin-right: 5px;">4.0 – 6.0</div> <div style="margin-right: 5px;">(prepared)</div> <div style="margin-left: 20px;">-</div> </div>	<p style="text-align: center;">≤ 400</p> <p style="text-align: center;">-</p> <p style="text-align: center;">-</p> <p style="text-align: center;">-</p>
Insulation material with associated method of fixing	Mechanically fixed ETICS with profiles and supplementary adhesive: <ul style="list-style-type: none"> • Insulation product (see annex 1 for product characteristics) factory-prefabricated expanded polystyrene (EPS) <ul style="list-style-type: none"> - standard EPS • Supplementary adhesive (equal to bonded ETICS; minimum bonded surface 20 %) 	-	60 to 200

	Components National application documents shall be taken into account	Coverage [kg/m ²]	Thickness [mm]				
Insulation material with associated method of fixing	<ul style="list-style-type: none"> • Profiles (see annex 3 for product characteristics) <ul style="list-style-type: none"> - villerit Halteschiene - villerit Verbindungsschiene Polyvinyl chloride (PVC) profiles • Anchors for profiles (see annex 2 for product characteristics) <ul style="list-style-type: none"> - WS 8 L - WS 8 N - ejothem SDK U - SDF-K plus, - ejothem NK U 						
	<p>Mechanically fixed ETICS with anchors and supplementary adhesive:</p> <ul style="list-style-type: none"> • Insulation product (see annex 1 for product characteristics) factory-prefabricated expanded polystyrene (EPS) <ul style="list-style-type: none"> - standard EPS • Supplementary adhesive (equal to bonded ETICS, minimum bonded surface 40 %) • Anchors for insulation product all anchors with ETA according to EAD 330196-00-0604¹ with characteristics defined in annex 2 	-	60 to 400				
Base coat	<p>villerit Inno Therm villerit activDRY Klebe- und Armierungsmörtel villerit Baukleber VWS 850 grau villerit Baukleber VWS 850 weiß villerit KA-Basic Klebe- und Armierungsmörtel Identical with the equally named adhesive(s) given above.</p>	<table style="border: none;"> <tr> <td style="font-size: 2em; vertical-align: middle;">}</td> <td style="padding-left: 10px;">4.0 – 7.0 (prepared)</td> </tr> <tr> <td style="font-size: 2em; vertical-align: middle;">}</td> <td style="padding-left: 10px;">4.0 – 6.0 (prepared)</td> </tr> </table>	}	4.0 – 7.0 (prepared)	}	4.0 – 6.0 (prepared)	<p>Mean (dry): about 5.0</p> <p>Mean (dry): about 4.0</p>
}	4.0 – 7.0 (prepared)						
}	4.0 – 6.0 (prepared)						
Glass fibre mesh	<p>Armierungsgewebe fein (see annex 4 for product characteristics) Alkali- and slide-resistant glass fibre mesh with mass per unit area of about 160 g/m² and mesh size of about 4.0 mm x 4.0 mm.</p>	-	-				
Key coat	<p>villerit Quarzbrücke Ready to use pigmented acrylic-resin dispersion liquid To be used with all finishing coats indicated hereafter. For the compatibility with the finishing coats see below.</p>	ca. 0.3 l/m ²	-				
Finishing coat	<p>To use with key coat "villerit Quarzbrücke" if applicable:**:</p> <ul style="list-style-type: none"> • Ready to use paste – acrylic-resin binder: 						

¹ EAD 330196-00-0604 Plastic anchors for fixing of external thermal insulation composite systems with rendering

Components National application documents shall be taken into account	Coverage [kg/m ²]	Thickness [mm]
<p>villerit Deko K⁺ (particle size 1 – 1.5 – 2.3 and 4 mm)</p> <p>villerit Deko R⁺ (particle size 1 – 1.5 – 2.3 and 4 mm)</p> <ul style="list-style-type: none"> • Ready to use paste – acryliosiloxane binder: <ul style="list-style-type: none"> villerit Siliconit K⁺ (particle size 1.5 – 2 – 3 and 4 mm) villerit Siliconit R⁺ (particle size 1.5 – 2 – 3 and 4 mm) villerit activDRY Siliconit K⁺ (particle size 1.5 – 2 – 3 and 4 mm) villerit activDRY Siliconit R⁺ (particle size 1.5 – 2 – 3 and 4 mm) <p>Application without key coat:</p> <ul style="list-style-type: none"> • Ready to use pastes – silicate binder: <ul style="list-style-type: none"> villerit Silan K⁺ (particle size 1.5 – 2 and 3 mm) villerit Silan R⁺ (particle size 1.5 – 2 – 3 and 4 mm) villerit activDRY Silan K⁺ (particle size 1.5 – 2 and 3 mm) villerit activDRY Silan R⁺ (particle size 1.5 – 2 – 3 and 4 mm) • Thin layered cement based powder requiring addition of about 27 % of water: <ul style="list-style-type: none"> villerit Rustikalputz (particle size 1.5 – 2 and 3 mm) villerit Rauhputz (particle size 1.5 – 2 – 3 – 4 – 5 and 6 mm) villerit Stockputz (particle size 1.5 – 2 – 3 – 4 – 5 and 6 mm) villerit activDRY Mineralputz Rustik (particle size 1.5 – 2 and 3 mm) 	<p>2.2 – 5.0</p> <p>2.2 – 4.0</p> <p>2.2 – 5.0</p> <p>2.2 – 4.0</p> <p>2.2 – 5.0</p> <p>2.5 – 3.5 (prepared)</p> <p>2.2 – 6.6 (prepared)</p> <p>2.2 – 6.6 (prepared)</p> <p>2.5 – 3.5 (prepared)</p>	<p>Regulated by particle size</p> <p>Regulated by particle size</p>

	Components National application documents shall be taken into account	Coverage [kg/m ²]	Thickness [mm]
	<p>villerit activDRY Mineralputz R[*] (particle size 1.5 – 2 – 3 – 4 – 5 and 6 mm)</p> <p>villerit activDRY Mineralputz K[*] (particle size 1.5 – 2 – 3 – 4 – 5 and 6 mm)</p> <p>villerit Rauhputz SLC^{***} (particle size 1.5 – 2 – 3 – 4 – 5 and 6 mm)</p> <p>villerit Stockputz SLC^{***} (particle size 1.5 – 2 – 3 – 4 – 5 and 6 mm)</p> <ul style="list-style-type: none"> Thick layered cement based powder requiring addition of about 21 % of water: <p>villerit Edelkratzputz variant WDVS^{***} (particle size 1 – 2 – 3 – 4 und 5 mm)</p>	<p>2.2 – 6.6 (prepared)</p> <p>2.2 – 6.6 (prepared)</p> <p>1.5 – 5.0 (prepared)</p> <p>1.5 – 5.0 (prepared)</p> <p>15 – 18 (prepared)</p>	<p>Regulated by particle size 8 – 10</p>
Ancillary material	Remains the responsibility of the manufacturer.		
<p>* K / R indicates different structures of the finishing coat.</p> <p>** The instruction to the installer concerning the use of a key coat remains the responsibility of the manufacturer.</p> <p>*** Only to be used with base coats "villerit Baukleber VWS 850 grau/weiß" and "villerit KA-Basic Klebe- und Armierungsmörtel"</p>			

2. Specification of the intended use in accordance with the applicable European assessment Document (hereinafter called EAD)

2.1 Intended use

This ETICS is intended to be used as external insulation to the walls of buildings made of masonry (bricks, blocks, stones ...) or concrete (cast on site or as prefabricated panels) with and without rendering. The characteristics of the walls shall be verified prior to use of the ETICS, especially regarding conditions for reaction to fire classification and for fixing of the ETICS either by bonding or mechanically. It shall be designed to give the wall to which it is applied satisfactory thermal insulation.

The ETICS is non load-bearing construction element. It does not contribute directly to the stability of the wall on which it is installed, but it can contribute to durability by providing enhanced protection from the effects of weathering.

The ETICS can be used on new or existing (retrofit) vertical walls.

The ETICS is not intended to ensure the air tightness of the building structure.

The choice of the method of fixing depends on the characteristics of the substrate, which could need preparation (see clause 7.2.1 of ETAG 004) and on the national instructions.

The verifications and assessment methods on which this European Technical Assessment (hereinafter called ETA) is based lead to the assumption of a working life of the ETICS "villerit Inno Therm EPS" of at least 25 years. The indications given on the working life cannot be interpreted as a guarantee given by the manufacturer, but are to be regarded only as a means for choosing the right products in relation to the assumed economically reasonable working life of the works.

2.2 Manufacturing

The ETA is issued for the ETICS on the basis of agreed data/information, deposited with the DIBt, which identifies the ETICS that has been assessed and judged. Changes to the ETICS or the components or their production process, which could result in this deposited data/information being incorrect, should be notified to the DIBt before the changes are introduced. The DIBt will decide whether such changes affect the approval and consequently the validity of the CE marking on the basis of the approval and if so whether further assessment or alterations to the approval shall be necessary.

2.3 Design and installation

The installation instructions including special installation techniques and provisions for the qualification of the personnel are given in the manufacturer's technical documentation. Design, installation and execution of ETICS are to be in conformity with national documents. Such documents and the level of their implementation in Member States' legislation are different. Therefore, the assessment and declaration of performance are done taking into account general assumptions introduced in the chapters 7.1 and 7.2 of ETAG 004 used as EAD, which summarize how information introduced in the ETA and related documents is intended to be used in the construction process and gives advice to all parties interested when normative documents are missing.

2.4 Packing, transport and storage

The information on packaging, transport and storage is given in the manufacturer's technical documentation. It is the responsibility of the manufacturer to ensure that this information is made know to the concerned people.

2.5 Use, maintenance, repair

The finishing coat shall normally be maintained in order to fully preserve the ETICS performance. Maintenance includes at least:

- visual inspection of the ETICS
- the repairing of localised damaged areas due to accidents
- the aspect maintenance with products adapted and compatible with the ETICS (possibly after washing or ad hoc preparation)

Only products which are compatible with the ETICS shall be used.

Necessary repairs should be performed as soon as the need has been identified.

The information on use, maintenance and repair is given in the manufacturer's technical documentation.

It is the responsibility of the manufacturer to ensure that this information is made know to the concerned people.

3 Characteristics of products and methods of verification

3.0 General

The performances of the kit as described in this chapter are valid provided that the components of the kit comply with Annexes 1 to 4.

3.1 Mechanical resistance and stability (BWR 1)

not relevant

**3.2 Safety in case of fire (BWR 2)
Reaction to fire (ETAG 004 - clause 5.1.2)**

Configurations	Organic content	Flame retardant content	Euroclass according to EN 13501-1:2007
Base coat	max. 3.1 %	no flame retardent	
EPS - insulation product	in quantity ensuring Euroclass E according to EN 13501-1	in quantity ensuring Euroclass E according to EN 13501-1	
Profile	-	-	
Anchors	-	-	
rendering system : Base coat with finishing coat and compatible key coat indicated in clause 1.2:			
villerit Stockputz / Rauputz / Rustikalputz villerit activDRY Mineralputz K/R/Rustik villerit Stockputz SLC / Rauhputz SLC villerit Edelkratzput variant WDVS	max. 2.5 %	no flame retardent	B - s1,d0
villerit Deko K/R villerit Siliconit K/R villerit activDRY Siliconit K/ R	max. 9.9 %	no flame retardent	B - s1,d0
villerit Silan K/R, villerit activDry Silan K/R	max. 4.8 %	no flame retardent	B - s2,d0

3.3 Hygiene, health and environment (BWR 3)

3.3.1 Water absorption (capillarity test) (ETAG 004 - clause 5.1.3.1)

Base coat:

Base coat	Water absorption after 1 h < 1.0 kg/m ²	Water absorption after 24 h < 0.5 kg/m ²
villerit Inno Therm	x	
villerit activDRY Klebe- und Armierungsmörtel	x	
villerit Baukleber VWS 850 grau	x	x
villerit Baukleber VWS 850 weiß	x	x
villerit KA-Basic Klebe- und Armierungsmörtel	x	x

Rendering system:

		Water absorption after 24 hours	
		< 0.5 kg/m ²	≥ 0.5 kg/m ²
Rendering system: Base coat " villerit Inno Therm " or " villerit activDRY Klebe- und Armierungsmörtel " with finishing coat indicated in clause 1.2:	villerit Deko		x
	villerit Siliconit		x
	villerit activDRY Siliconit		x
	villerit Silan		x
	villerit activDRY Silan		x
	villerit Rustikalputz		x
	villerit Rauhputz		x
	villerit Stockputz		x
	villerit activDRY Mineralputz		x

		Wasseraufnahme after 24 h	
		< 0,5 kg/m ²	≥ 0,5 kg/m ²
Rendering system: Base coat " villerit Baukleber VWS 850 grau/weiß " or " villerit KA-Basic Klebe- und Armierungsmörtel " with finishing coat indicated in clause 1.2:	villerit Deko		x
	villerit Siliconit		x
	villerit activDRY Siliconit		x
	villerit Silan		x
	villerit activDRY Silan		x
	villerit Rustikalputz	x	
	villerit Rauhputz	x	
	villerit Stockputz	x	
	villerit activDRY Mineralputz		x
	villerit Stockputz SLC		x
	villerit Rauhputz SLC		x
	villerit Edelkratzputz variant WDVS	x	

3.3.2 Hydrothermal behaviour (ETAG 004 - clause 5.1.3.2)

Pass (without defects)

Freeze/thaw behaviour

The ETICS with base coats "villerit Inno Therm" and "villerit activDRY Klebe- und Armierungsmörtel" with all finishing coats has been assessed as freeze/thaw resistant according to the simulated method.

The ETICS with base coats "villerit Baukleber VWS 850 grau/weiß" and "villerit KA-Basic Klebe- und Armierungsmörtel" with the finishing coats "villerit Deko", "villerit Siliconit", "villerit activDRY Siliconit", "villerit Silan", "villerit activDRY Silan", "villerit activDRY Mineralputz", "villerit Stockputz SLC" and "villerit Rauhputz SLC" has been assessed as freeze/thaw resistant according to the simulated method.

English translation prepared by DIBt

The water absorption of the base coats "villerit Baukleber VWS 850 grau/weiß" and "villerit KA-Basic Klebe- und Armierungsmörtel" as well as the finishing coats "villerit Rustikalputz", "villerit Rauhputz", "villerit Stockputz" and "villerit Edelkratzputz variant WDVS" is less than 0.5 kg/m² after 24 hours. The ETICS is so assessed as freeze/thaw resistant.

3.3.3 Impact resistance (ETA G004 – clause 5.1.3.3)

The verified resistance to hard body impact of the ETICS results in the classification into categories listed below.

Rendering system: Base coat " villerit Inno Therm " or " villerit activDRY Klebe- und Armierungsmörtel " with finishing coat and compatible key coat indicated in clause 1.2:	Single standard mesh: " villerit Armierungsgewebe fein "
villerit Deko	category II
villerit Siliconit	category II
villerit activDRY Siliconit	category II
villerit Silan	category II
villerit activDRY Silan	category II
villerit Rustikalputz	category II
villerit Rauhputz	category II
villerit Stockputz	category II
villerit activDRY Mineralputz	category II

Rendering system: Base coat " villerit Baukleber VWS 850 grau/weiß " or " villerit KA-Basic Klebe- und Armierungsmörtel " with finishing coat and compatible key coat indicated in clause 1.2:	Single standard mesh: " villerit Armierungsgewebe fein "
villerit Deko	category I
villerit Siliconit	category I
villerit activDRY Siliconit	category I
villerit Silan	category I
villerit activDRY Silan	category I
villerit Rustikalputz	category I
villerit Rauhputz	category I
villerit Stockputz	category I
villerit activDRY Mineralputz	category I
villerit Stockputz SLC	category II
villerit Rauhputz SLC	category II
villerit Edelkratzputz variant WDVS	category II

3.3.4 Water vapour permeability (ETAG004 – clause 5.1.3.4)

Rendering system: Base coat "villerit Inno Therm" or "villerit activDRY Klebe- und Armierungsmörtel" with finishing coat indicated in clause 1.2: (evaluated without decorative coating or key coat)	Equivalent air thickness s_d
villerit Deko	≤ 1.0 m (Test result obtained with layer thickness $t = 4$ mm: 0.3 m)
villerit Siliconit	≤ 1.0 m (Test result obtained with layer thickness $t = 4$ mm: 0.3 m)
villerit activDRY Siliconit	≤ 1.0 m (Test result obtained with layer thickness $t = 4$ mm: 0.3 m)
villerit Silan	≤ 1.0 m (Test result obtained with layer thickness $t = 4$ mm: 0.1 m)
villerit activDRY Silan	≤ 1.0 m (Test result obtained with layer thickness $t = 4$ mm: 0.1 m)
villerit Rustikalputz	≤ 1.0 m (Test result obtained with layer thickness $t = 3$ mm: 0.1 m)
villerit Rauputz	≤ 1.0 m (Test result obtained with layer thickness $t = 6$ mm: 0.1 m)
villerit Stockputz	≤ 1.0 m (Test result obtained with layer thickness $t = 6$ mm: 0.1 m)
villerit activDRY Mineralputz Rustik	≤ 1.0 m (Test result obtained with layer thickness $t = 3$ mm: 0.1 m)
villerit activDRY Mineralputz	≤ 1.0 m (Test result obtained with layer thickness $t = 6$ mm: 0.1 m)

Rendering system: Base coat "villerit Baukleber VWS 850 grau/weiß" or "villerit KA-Basic Klebe- und Armierungsmörtel" with finishing coat and compatible key coat indicated in clause 1.2:	Equivalent air thickness s_d
villerit Deko	≤ 1.0 m (Test result obtained with particle size $t = 3$ mm: 0.3 m)
villerit Siliconit	≤ 1.0 m (Test result obtained with particle size $t = 3$ mm: 0.3 m)
villerit activDRY Siliconit	≤ 1.0 m (Test result obtained with particle size $t = 3$ mm: 0.3 m)
villerit Silan	≤ 1.0 m (Test result obtained with particle size $t = 3$ mm: 0.1 m)

Rendering system: Base coat "villerit Baukleber VWS 850 grau/weiß" or "villerit KA-Basic Klebe- und Armierungsmörtel" with finishing coat and compatible key coat indicated in clause 1.2:	Equivalent air thickness s_d
villerit activDRY Silan	≤ 1.0 m (Test result obtained with particle size t = 3 mm: 0.1 m)
villerit Rustikalputz	≤ 1.0 m (Test result obtained with particle size t = 3 mm: 0.1 m)
villerit Rauhputz	≤ 1.0 m (Test result obtained with particle size t = 3 mm: 0.1 m)
villerit Stockputz	≤ 1.0 m (Test result obtained with particle size t = 3 mm: 0.1 m)
villerit activDRY Mineralputz Rustik	≤ 1.0 m (Test result obtained with particle size t = 3 mm: 0.1 m)
villerit activDRY Mineralputz	≤ 1.0 m (Test result obtained with particle size t = 3 mm: 0.1 m)
villerit Stockputz SLC	≤ 1.0 m (Test result obtained with particle size t = 4 mm: 0.1 m)
villerit Rauhputz SLC	≤ 1.0 m (Test result obtained with particle size t = 4 mm: 0.1 m)
villerit Edelkratzputz variant WDVS	≤ 1.0 m (Test result obtained with particle size t = 4 mm: 0.1 m)

3.3.5 Release of dangerous substances (ETAG 004 - clause 5.1.3.5, EOTA TR 034)

Essential characteristic	Performance
Release of dangerous substances	no performance assessed

3.4 Safety and accessibility in use (BWR 4)

3.4.1 Bond strength between base coat and insulation product (EPS) (ETAG 004 - clause 5.1.4.1.1)

a) Base coat "villerit Inno Therm" and "villerit activDRY Klebe- und Armierungsmörte":

Conditioning		
Initial state	After hygrothermal cycles	After freeze/thaw test
≥ 0.08 MPa	Not tested	≥ 0.08 MPa

b) Base coat "villerit Baukleber VWS 850 grau/weiß" and "villerit KA-Basic Klebe- und Armierungsmörtel":

Conditioning		
Initial state	After hygrothermal cycles	After freeze/thaw test
≥ 0.08 MPa	≥ 0,08 MPa	≥ 0.08 MPa

English translation prepared by DIBt

3.4.2 Bond strength between adhesive and substrate resp. insulation product (EPS) (ETAG 004 – clauses 5.1.4.1.2 and 5.1.4.1.3)

Adhesive	Substrate resp. insulation product	Conditioning		
		Initial state	2 d immersion in water and 2 h drying	2 d immersion in water and 7 d drying
villerit Baukleber VWS 850	Concrete	≥ 0.25 MPa	≥ 0.08 MPa	≥ 0.25 MPa
	EPS	≥ 0.08 MPa	≥ 0.03 MPa	≥ 0.08 MPa
villerit Inno Therm	Concrete	≥ 0.25 MPa	≥ 0.08 MPa	≥ 0.25 MPa
	EPS	≥ 0.08 MPa	≥ 0.03 MPa	≥ 0.08 MPa
villerit activDRY Klebe- und Armierungsmörtel	Concrete	≥ 0.25 MPa	≥ 0.08 MPa	≥ 0.25 MPa
	EPS	≥ 0.08 MPa	≥ 0.03 MPa	≥ 0.08 MPa
villerit Baukleber VWS 850 grau/weiß	Beton	≥ 0,25 MPa	≥ 0,08 MPa	≥ 0,25 MPa
	EPS	≥ 0,08 MPa	≥ 0,03 MPa	≥ 0,08 MPa
villerit KA-Basic Klebe- und Armierungsmörtel	Concrete	≥ 0.25 MPa	≥ 0.08 MPa	≥ 0.25 MPa
	EPS	≥ 0.08 MPa	≥ 0.03 MPa	≥ 0.08 MPa

Bonded surface:

For bonded ETICS the calculated minimal bonded surface area, according to ETAG 004, clause 6.1.4.1.3 is 40 %.

3.4.3 Bond strength after ageing (ETAG 004 – clause 5.1.7.1):

<p>Rendering system: Base coat with finishing coat and compatible key coat indicated in clause 1.2</p>	villerit Deko	≥ 0,08 MPa
	villerit Siliconit	
	villerit activDRY Siliconit	
	villerit Silan	
	villerit activDRY Silan	
	villerit Rustikalputz	
	villerit Rauhputz	
	villerit Stockputz	
	villerit activDRY Mineralputz Rustik	
	villerit activDRY Mineralputz	
	villerit Stockputz SLC	
	villerit Rauhputz SLC	
	villerit Edelkratzputz variant WDVS	

3.4.4 Fixing strength (displacement test) (ETAG 004 - clause 5.1.4.2)

Test not required therefore no limitation of ETICS length required.

3.4.5 Wind load resistance (ETAG 004 - clause 5.1.4.3)

The following failure loads only apply to the listed combination of component characteristics and the characteristics of the insulation product given in annex 1.

3.4.5.1 Safety in use of mechanically fixed ETICS using profiles

Characteristics of the EPS (standard EPS)	Dimensions	500 mm x 500 mm
	Thickness	≥ 60 mm
	Tensile strength perpendicular to the faces	≥ 150 kPa
	Shear modulus	≥ 1.0 N/mm ²
Failure loads [N / panel] (Static Foam Block Test)	Horizontal profiles fixed every 30 cm and 49.4 cm long vertical connection profiles	Minimal: 950 Average: 1010

3.4.5.2 Safety in use of mechanically fixed ETICS using anchors

Apply to all anchors listed in the clause 1.2 mounted on the insulation panels surface				
Characteristics of the EPS (standard EPS)	Thickness		≥ 60 mm	
	Tensile strength perpendicular to the faces		≥ 100 kPa	
	Shear modulus		≥ 1.0 N/mm ²	
Plate diameter of anchor			Ø 60 mm	Ø 90 mm
Failure loads [N]	Anchors not placed at the panel joints (Static Foam Block Test)	R _{panel}	Minimal: 510 Average: 520	Minimal: 720 Average: 730
	Anchors placed at the panel joints (Pull-through test)	R _{joint}	Minimal: 400 Average: 430	Minimal: 430 Average: 470

The failure loads specified above for a plate diameter of anchor of 60 mm apply to the following anchors with deep mounting but only on the following conditions of installation:

Anchor	Thickness of the EPS [d]	Conditions of installation *
ejotherm STR U, ejotherm STR U 2G (ETA-04/0023)	100 mm > d ≥ 80 mm (for standard and elastified EPS)	– Maximum installation depth of the anchor plate: 15 mm (△ thickness of insulation cover) – Maximum depth of die: 5 mm
	≥ 100 mm (for standard and elastified EPS)	– Maximum installation depth of the anchor plate: 15 mm (△ thickness of insulation cover) – Maximum depth of die: 20 mm
TERMOZ 8 SV (ETA-06/0180)	≥ 80 mm (for standard EPS only)	– Maximum installation depth of the anchor plate: 15 mm (△ thickness of insulation cover)

* according to the appropriate ETA of anchor

3.4.6 Render strip tensile test (ETAG 004 – clause 5.5.4.1)

The average value of crack width of the base coats reinforced with the glass fibre mesh "villerit Armierungsgewebe fein" of the base coat reinforced with the different glass fibre meshes measured at a render strain value of 1 % is 0.22 mm.

3.5 Protection against noise (BWR 5)

For the protection against noise no performance was assessed for this product.

English translation prepared by DIBt

3.6 Energy economy and heat retention (BWR 6)

3.6.1 Thermal resistance

The nominal value of the additional thermal resistance R provided by the ETICS to the substrate wall is calculated in accordance with EN ISO 6946:2007 from the nominal value of the insulation product's thermal resistance R_D given accompanied to the CE marking and from the thermal resistance of the rendering system R_{render} which is about $0.02 \text{ (m}^2 \cdot \text{K)/W}$.

$$R = R_D + R_{render}$$

The thermal bridges caused by anchors profiles increases the thermal transmittance U . This influence had to take into account according to EN ISO 6946:2007

$$U_c = U + \chi_p \cdot n$$

Where: U_c : corrected thermal transmittance [$\text{W}/(\text{m}^2 \cdot \text{K})$]

n : number of anchors per m^2

χ_p : local influence of thermal bridge caused by an anchor. The values listed below can be taken into account if not specified in the anchor's ETA:

$\chi_p = 0.004 \text{ W/K}$ for anchors with a galvanized steel screw with the head covered by a plastic material

$\chi_p = 0.002 \text{ W/K}$ for anchors with a stainless steel screw covered by plastic anchors and for anchors with an air gap at the head of the screw

The thermal bridges caused by profiles are negligible.

3.7 Sustainable use of natural resources (BWR 7)

For the sustainable use of natural resources no performance was investigated for this product.

English translation prepared by DIBt

4 Assessment and verification of constancy of performance (AVCP) system applied, with reference to its legal base

According to the European Commission decision 97/556/EC amended by the European Commission decision 2001/596/EC, the assessment and verification of constancy of performance system (AVCP) applies suitable following table (see Annex V to Regulation (EU) No 305/2011).

Product	Intended use	Levels or classes (Reaction to fire)	Systems
"villerit Inno Therm EPS"	in external wall subject to fire regulations	A1 ⁽¹⁾ , A2 ⁽¹⁾ , B ⁽¹⁾ , C ⁽¹⁾	1
		A1 ⁽²⁾ , A2 ⁽²⁾ , B ⁽²⁾ , C ⁽²⁾ , D, E, (A1 to E) ⁽³⁾ , F	2+
	in external wall not subject to fire regulations	any	2+
⁽¹⁾ Products/materials for which a clearly identifiable stage in the production process results in an improvement of the reaction to fire classification (e.g. an addition of fire retardants or a limiting of organic material) ⁽²⁾ Products/materials not covered by footnote (1) ⁽³⁾ Products/materials that do not require to be tested for reaction to fire (e.g. products/materials of Classes A1 according to Commission Decision 96/603/EC)			

5 Technical details necessary for the implementation of the AVCP system, as provided for in the applicable European Assessment Document (EAD)

Technical details necessary for the implementation of the AVCP system are laid down in the control plan deposited at Deutsches Institut für Bautechnik.

Issued in Berlin on 30 April 2018 Deutsches Institut für Bautechnik

Dirk Brandenburger
Head of Department

beglaubigt:
Hartstock

**European Technical Assessment
ETA-06/0221**

English translation prepared by DIBt

Page 17 of 21 | 30 April 2018

Annexes:

Annex 1: Thermal insulation product characteristic

Annex 2: Anchors

Annex 3: Profiles

Annex 4: Reinforcement

Annex 1: Thermal insulation product characteristic

Factory-prefabricated, uncoated panels made of expanded polystyrene (EPS) to EN 13163:2015 shall be used, having the description and characteristics defined in the Table below.

Description and characteristics	For bonded ETICS		For mechanically fixed ETICS	
			with anchors and supplementary adhesive	with profiles and supplementary adhesive***
Reaction to fire; EN 13501-1:2007	Class E*			
Thermal resistance [(m ² ·K)/W]	Defined in the CE marking in reference to EN 13163:2015			
Tolerances				
Length; EN 822:2013	± 0.6 % or ± 3 mm whichever gives the greatest numerical tolerance (class L3)			
Width [mm]; EN 822:2013	± 2 (class W2)			
Thickness [mm]; EN 823:2013	± 1 (class T1)			
Squareness [mm/m]; EN 824:2013	± 2 (class S2)			
Flatness [mm/m]; EN 825:2013	5 (class P5)			
Dimensional stability under				
- laboratory conditions [%]; EN 1603:2013	± 0.2 (class DS(N)2)			
- specified temperature and humidity conditions [%]; EN 1604:2013	2 (level DS(70,-)2 or level DS(70,-)1)			
Water absorption (long term partial immersion) [kg/m ²]; EN 12087:2013	W _{ip} ≤ 0.5			
Water vapour diffusion resistance factor; EN 12086:2013	μ = 20 – 78			
Tensile strength perpendicular to the faces in dry conditions** [kPa]; EN 1607:2013 - standard EPS	σ _{mt} ≥ 80	σ _{mt} ≥ 100	σ _{mt} ≥ 150	
Bending strength** [kPa]; EN 12089:2013	σ _b ≥ 50			
Apparent density [kg/m ³]; EN 1602:2013	ρ _a ≤ 30			
Shear strength** [kPa]; EN 12090:2013	20 ≤ f _{tk} ≤ 170			
Shear modulus [MPa]; EN 12090:2013 - standard EPS	1.0 ≤ G _m ≤ 3.8			
Testing of characteristics see EN 13163:2015.				
* See the conditions of clause 3.2 for the EPS.				
** Minimal value of all single values				
*** Thermal insulation materials for mechanically fixed ETICS with profiles must circumferentially at the edges, 24 mm from the inner surface, get an approx. 3 mm wide and 13 to 18 mm deep groove cut-in at the factory.				

Annex 2: Anchors

All anchors with ETA according to EAD 330196-00-0604¹ with characteristics having the description below shall be used in the mechanically fixed ETICS:

- plate diameter of anchor ≥ 60 mm resp. ≥ 90 mm
- plate stiffness ≥ 0.3 kN/mm
- load resistance of the anchor plate ≥ 1.0 kN

These characteristics and the characteristic tension resistance of the anchors shall be taken from the corresponding ETA.

The anchors listed in the Table in clause 1.2 with reference to the respective ETA shall be used in the mechanically fixed ETICS with profiles for fixing the horizontal profiles.

Trade name	ETA-number
WS 8 L	ETA-02/0019
WS 8 N	ETA-03/0019
IsoFux ND-8Z	ETA-04/0032
SDF-K plus,	ETA-04/0064
ejothem NK U	ETA-05/0009

Annex 3: Profiles

Polyvinyl chloride (PVC) profiles, PVC-U, EGL, 082-05-T33 to EN ISO 1163-1:1999 are to be used in the mechanically fixed ETICS with profiles.

The Pull-through resistance of fixings from profiles is ≥ 500 N.

Horizontal profile – "Halteleiste PVC" (dimensions in millimetres)

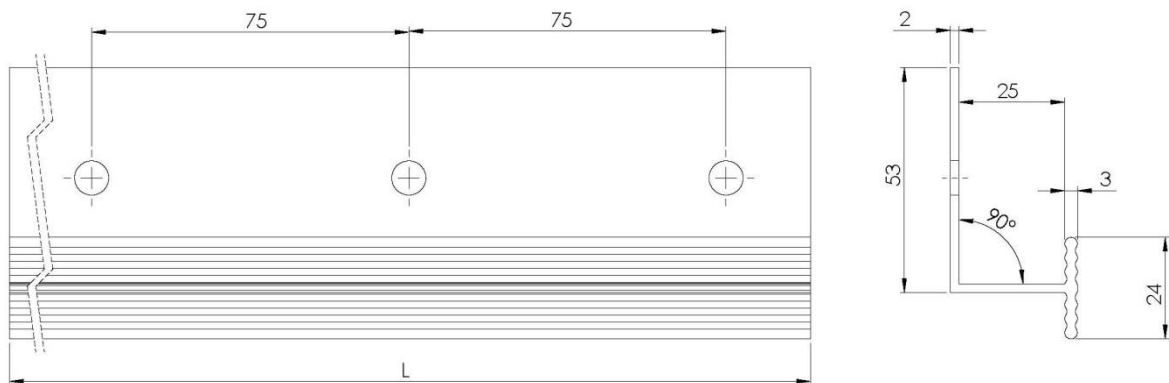

Vertical connection profile – "Verbindungsleiste PVC" (dimensions in millimetres)

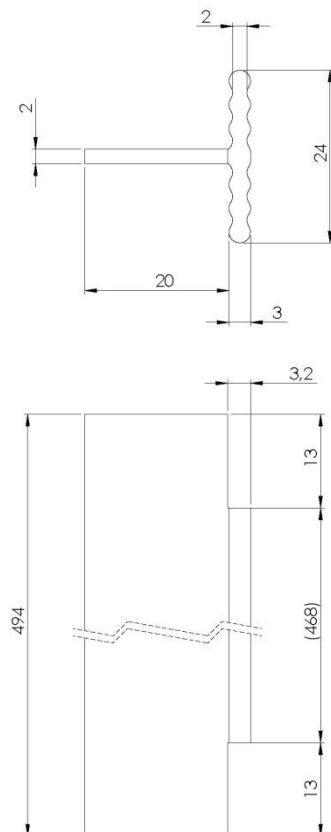

Annex 4: Reinforcement (glass fibre mesh)

Characteristics (alkali resistance): Pass

	Description	Residual strength after ageing [N/mm]	Relative residual strength after ageing, of the strength in the as-delivered state [%]
"villerit Armierungsge webe fein"	Alkali- and slide-resistant glass fibre mesh with mass per unit area of about 160 g/m ² and mesh size of about 4.0 mm x 4.0 mm	≥ 20	≥ 50