

Approval body for construction products  
and types of construction

Bautechnisches Prüfamt

An institution established by the Federal and  
Laender Governments



## European Technical Assessment

ETA-07/0284  
of 14 March 2018

English translation prepared by DIBt - Original version in German language

### General Part

Technical Assessment Body issuing the  
European Technical Assessment:

Deutsches Institut für Bautechnik

Trade name of the construction product

PROBAU-WDV-System

Product family  
to which the construction product belongs

Product area code: 4  
External Thermal Insulation Composite System with  
rendering on expanded polystyrene for the use as  
external insulation of building walls

Manufacturer

BAHAG AG  
Gutenbergstraße 21  
68167 Mannheim  
DEUTSCHLAND

Manufacturing plant

BAHAG AG  
Gutenbergstraße 21  
68167 Mannheim  
DEUTSCHLAND

This European Technical Assessment  
contains

18 pages including 4 annexes which form an integral part  
of this assessment.

Annex 5 Control Plan contains confidential information  
and is not included in the European Technical  
Assessment when that assessment is publicly available

This European Technical Assessment is  
issued in accordance with Regulation (EU)  
No 305/2011, on the basis of

ETAG 004, edition 2000, amended 2013,  
used as EAD according to Article 66 Paragraph 3 of  
Regulation (EU) No 305/2011.

The European Technical Assessment is issued by the Technical Assessment Body in its official language. Translations of this European Technical Assessment in other languages shall fully correspond to the original issued document and shall be identified as such.

Communication of this European Technical Assessment, including transmission by electronic means, shall be in full. However, partial reproduction may only be made with the written consent of the issuing Technical Assessment Body. Any partial reproduction shall be identified as such.

This European Technical Assessment may be withdrawn by the issuing Technical Assessment Body, in particular pursuant to information by the Commission in accordance with Article 25(3) of Regulation (EU) No 305/2011.

## Specific Part

### 1 Technical description of the product

#### 1.1 Definition of the kit

This product is an External Thermal Insulation Composite System (ETICS) with rendering - a kit comprising components which are factory-produced by the manufacturer or component suppliers. It's made up on site from these. The ETICS manufacturer is ultimately responsible for all components of the ETICS specified in this ETA.

The ETICS kit comprises a prefabricated insulation product of expanded polystyrene (EPS) to be bonded and if it necessary additional mechanically fixed onto a wall. The methods of fixing and the relevant components are specified in the table below.

The insulation product is faced with a rendering system consisting of one base coat and finishing coat (site applied), in which the base coat contains reinforcement. The rendering is applied directly to the insulating panels, without any air gap or disconnecting layer.

The ETICS may include special fittings (e.g. base profiles, corner profiles ...) for connection to adjacent building elements (apertures, corners, parapets ...). Assessment and performance of these components is not addressed in this ETA, however the ETICS manufacturer is responsible for adequate compatibility and performance within the ETICS when the components are delivered as a part of the kit.

#### 1.2 Composition of the ETICS

	Components National application documents shall be taken into account	Coverage [kg/m <sup>2</sup> ]	Thickness [mm]
Insulation material with associated method of fixing	<b>Bonded ETICS:</b> <ul style="list-style-type: none"> <li>• <b>Insulation product</b> (see annex 1 for product characteristics) factory-prefabricated expanded polystyrene (EPS) <ul style="list-style-type: none"> <li>- standard EPS</li> <li>- elastified EPS</li> </ul> </li> <li>• <b>Adhesives</b> <ul style="list-style-type: none"> <li>- <b>PROBAU Klebe- und Armierungsmörtel grau</b></li> <li>- <b>PROBAU Klebe- und Armierungsmörtel weiß</b></li> <li>- <b>PROBAU Klebe- und Armierungsmörtel MG II</b> (cement based powder requiring addition of about 25 % of water)</li> <li>- <b>PROBAU WDVS-Spachtel</b> (organic based ready to use paste)</li> </ul> </li> </ul>	<p>–</p> <p>–</p> <p>4.0 – 6.0</p> <p>4.0 – 6.0</p> <p>4.0 – 6.0 (prepared)</p> <p>3.0 – 4.0 (prepared)</p>	<p>≤ 400</p> <p>≤ 200</p> <p>–</p> <p>–</p> <p>–</p> <p>–</p>
	<b>Mechanically fixed ETICS with profiles and supplementary adhesive:</b> <ul style="list-style-type: none"> <li>• <b>Insulation product</b> (see annex 1 for product characteristics) factory-prefabricated expanded polystyrene (EPS) <ul style="list-style-type: none"> <li>- standard EPS</li> </ul> </li> <li>• <b>Supplementary adhesive</b> (equal to bonded ETICS)</li> </ul>	<p>–</p>	<p>60 – 200</p>

	<b>Components</b> National application documents shall be taken into account	<b>Coverage</b> [kg/m <sup>2</sup> ]	<b>Thickness</b> [mm]
<b>Insulation material with associated method of fixing</b>	<ul style="list-style-type: none"> <li>• <b>Profiles</b> (see annex 3 for product characteristics) <ul style="list-style-type: none"> <li>- "PROBAU Halteleisten PVC" and</li> <li>- "PROBAU Verbindungsleisten PVC"</li> </ul> Polyvinyl chloride (PVC) profiles </li> <li>• <b>Anchors for profiles</b> (see annex 2 for product characteristics) <ul style="list-style-type: none"> <li>- WS 8 L</li> <li>- WS 8 N</li> <li>- ejothem SDK U</li> <li>- SDF-K plus</li> <li>- ejothem NK U</li> </ul> </li> </ul>		
	<p><b>Mechanically fixed ETICS with anchors and supplementary adhesive:</b></p> <ul style="list-style-type: none"> <li>• <b>Insulation product</b> (see annex 1 for product characteristics) factory-prefabricated expanded polystyrene (EPS) <ul style="list-style-type: none"> <li>- standard EPS</li> <li>- elastified EPS</li> </ul> </li> <li>• <b>Supplementary adhesive</b> (equal to bonded ETICS)</li> <li>• <b>Anchors for insulation product</b> all anchors with ETA according to EAD330196-00-0604<sup>1</sup> with characteristics defined in annex 2</li> </ul>	<p>–</p> <p>–</p>	<p>60 – 400</p> <p>60 – 200</p>
<b>Base coat</b>	<p><b>PROBAU Klebe- und Armierungsmörtel grau</b> <b>PROBAU Klebe- und Armierungsmörtel weiß</b> identical with the equally named adhesives given above.</p>	<p>4.5 – 7.5 (prepared)</p>	<p>3.0 – 5.0 (dry)</p>
<b>Glass fibre mesh</b>	<p><b>PROBAU Armierungsgewebe F</b> (see annex 4 for product characteristics) Alkali- and slide-resistant glass fibre mesh with mass per unit area of about 160 g/m<sup>2</sup> and mesh size of about 4.0 mm x 4.0 mm</p>	<p>–</p>	<p>–</p>
<b>Key coat</b>	<p><b>PROBAU Silikatverdünner</b> Ready to use pigmented liquid – silicate/acrylic binder</p>	<p>about 0.15 l/m<sup>2</sup></p>	<p>–</p>
	<p><b>PROBAU Edelputzgrundierung</b> Ready to use pigmented liquid – acrylic binder For the compatibility with the finishing coats: see below.</p>	<p>about 0.20 l/m<sup>2</sup></p>	<p>–</p>

<sup>1</sup>

EAD330196-00-0604

Plastic anchors for fixing of external thermal insulation composite systems with rendering

	Components National application documents shall be taken into account	Coverage [kg/m <sup>2</sup> ]	Thickness [mm]
<b>Finishing coat</b>	<p><b>To use with key coat "PROBAU Edelputzgrundierung" if applicable*:</b></p> <ul style="list-style-type: none"> <li>Thick layered cement based powder requiring addition of about 22 % of water: <b>PROBAU Kratzputz</b> (particle size 3 mm)</li> </ul>	20.0 – 25.0 (prepared)	12.0 – 15.0
	<ul style="list-style-type: none"> <li>Thin layered cement based powder requiring addition of about 27 % of water: <b>PROBAU Münchener Rauputz</b> (particle size 2 – 3 mm)</li> <li><b>PROBAU Scheibenputz</b> (particle size 1.5 – 2 – 3 and 4 mm)</li> <li><b>PROBAU Marmorputz</b> (particle size 1 mm) (particle size 1.5 – 2 and 2,5 mm)</li> <li>Thin layered cement based powder requiring addition of 36 to 40 % of water: <b>PROBAU Strukturalputz</b> (Korngröße 1.5 – 2 and 3 mm)</li> <li>Ready to use paste – acrylic/vinyllic binder: <b>PROBAU Kunstharzputz</b> (particle size 1.5 – 2 – 3 and 4 mm)</li> <li>Ready to use paste – acrylic/vinyllic/siloxane binder <b>PROBAU Silikonharzputz</b> (particle size 1.5 – 2 and 3 mm)</li> <li><b>PROBAU Siloxanputz</b> (particle size 1.5 – 2 and 3 mm)</li> </ul> <p><b>To use with key coat "PROBAU Silikatverdünner" if applicable*:</b></p> <ul style="list-style-type: none"> <li>Ready to use pastes – silicate/acrylic binder: <b>PROBAU Silikatputz</b> (particle size 1.5 – 2 and 3 mm)</li> </ul>	<p>3.5 – 5.0 (prepared)</p> <p>2.5 – 6.5 (prepared)</p> <p>1.6 – 8.0 2.5 – 5.0 (prepared)</p> <p>2.0 – 4.5 (prepared)</p> <p>2.0 – 4.0 (prepared)</p> <p>2.0 – 4.0 (prepared)</p> <p>2.0 – 4.0 (prepared)</p> <p>2.0 – 3.8 (prepared)</p>	<p>Regulated by particle size</p> <p>1.0 – 5.0</p> <p>Regulated by particle size</p> <p>1.5 – 4.0</p> <p>1.5 – 3.0</p> <p>1.5 – 3.0</p> <p>1.5 – 3.0</p>
<b>Ancillary material</b>	Remains the responsibility of the manufacturer.		
* The instruction to the installer concerning the use of a key coat remains the responsibility of the manufacturer.			

English translation prepared by DIBt

## **2. Specification of the intended use in accordance with the applicable European assessment Document (hereinafter called EAD)**

### **2.1 Intended use**

This ETICS is intended to be used as external insulation to the walls of buildings made of masonry (bricks, blocks, stones ...) or concrete (cast on site or as prefabricated panels) with and without rendering. The characteristics of the walls shall be verified prior to use of the ETICS, especially regarding conditions for reaction to fire classification and for fixing of the ETICS either by bonding or mechanically. It shall be designed to give the wall to which it is applied satisfactory thermal insulation.

The ETICS is non load-bearing construction element. It does not contribute directly to the stability of the wall on which it is installed, but it can contribute to durability by providing enhanced protection from the effects of weathering.

The ETICS can be used on new or existing (retrofit) vertical walls.

The ETICS is not intended to ensure the air tightness of the building structure.

The choice of the method of fixing depends on the characteristics of the substrate, which could need preparation (see clause 7.2.1 of ETAG 004) and on the national instructions.

The verifications and assessment methods on which this European Technical Assessment (hereinafter called ETA) is based lead to the assumption of a working life of the ETICS "PROBAU-WDV-System" of at least 25 years. The indications given on the working life cannot be interpreted as a guarantee given by the manufacturer, but are to be regarded only as a means for choosing the right products in relation to the assumed economically reasonable working life of the works.

### **2.2 Manufacturing**

The ETA is issued for the ETICS on the basis of agreed data/information, deposited with the DIBt, which identifies the ETICS that has been assessed and judged. Changes to the ETICS or the components or their production process, which could result in this deposited data/information being incorrect, should be notified to the DIBt before the changes are introduced. The DIBt will decide whether such changes affect the approval and consequently the validity of the CE marking on the basis of the approval and if so whether further assessment or alterations to the approval shall be necessary.

### **2.3 Design and installation**

The installation instructions including special installation techniques and provisions for the qualification of the personnel are given in the manufacturer's technical documentation.

Design, installation and execution of ETICS are to be in conformity with national documents. Such documents and the level of their implementation in Member States' legislation are different. Therefore, the assessment and declaration of performance are done taking into account general assumptions introduced in the chapters 7.1 and 7.2 of ETAG 004 used as EAD, which summarize how information introduced in the ETA and related documents is intended to be used in the construction process and gives advice to all parties interested when normative documents are missing.

### **2.4 Packing, transport and storage**

The information on packaging, transport and storage is given in the manufacturer's technical documentation. It is the responsibility of the manufacturer to ensure that this information is made know to the concerned people.

English translation prepared by DIBt

## 2.5 Use, maintenance, repair

The finishing coat shall normally be maintained in order to fully preserve the ETICS performance. Maintenance includes at least:

- visual inspection of the ETICS
- the repairing of localized damaged areas due to accidents
- the aspect maintenance with products adapted and compatible with the ETICS (possibly after washing or ad hoc preparation)

Only products which are compatible with the ETICS shall be used.

Necessary repairs should be performed as soon as the need has been identified.

The information on use, maintenance and repair is given in the manufacturer's technical documentation.

It is the responsibility of the manufacturer to ensure that this information is made know to the concerned people.

## 3 Characteristics of products and methods of verification

### 3.0 General

The performances of the kit as described in this chapter are valid provided that the components of the kit comply with Annexes 1 to 4.

### 3.1 Mechanical resistance and stability (BWR 1)

not relevant

### 3.2 Safety in case of fire (BWR 2)

#### Reaction to fire (ETAG 004 - clause 5.1.2)

Configurations	Organic content	Flame retardant	Euroclass according to EN 13501-1:2007
Base coat	max. 2.1 %	no flame retardant	B – s1,do
EPS - insulation product	in quantity ensuring Euroclass E according to EN 13501-1	In quantity ensuring Euroclass E according to EN 13501-1	
Profiles	-	-	
Anchors	-	-	
<b>rendering system:</b> Base coat with finishing coat and compatible key coat hereafter indicated:			
PROBAU Münchner Rauputz, PROBAU Scheibenputz, PROBAU Strukturalputz, PROBAU Marmorputz, PROBAU Kratzputz with PROBAU Edelputzgrundierung	max. 1.2 %	no flame retardant	

Configurations	Organic content	Flame retardant content	Euroclass according to EN 13501-1:2007
PROBAU Silikatputz with PROBAU Silikatverdünner PROBAU Kunstharzputz, PROBAU Silikonharzputz, PROBAU Siloxanputz with PROBAU Edelputzgrundierung	max. 9.7 %	min. 3 %	B – s1,do

### 3.3 Hygiene, health and environment (BWR 3)

#### 3.3.1 Water absorption (capillarity test) (ETAG 004 - clause 5.1.3.1)

##### Base coat:

- Water absorption after 1 hour < 1.0 kg/m<sup>2</sup>
- Water absorption after 24 hours < 0.5 kg/m<sup>2</sup>

Base coat	Water absorption after 1 h < 1 kg/m <sup>2</sup>	Water absorption after 24 h < 0.5 kg/m <sup>2</sup>
PROBAU Klebe- und Armierungsmörtel grau/weiß	x	x

##### Rendering system:

Rendering system: Base coats with finishing coat and compatible key coat hereafter indicated:		Water absorption after 24 hours	
		< 0.5 kg/m <sup>2</sup>	≥ 0.5 kg/m <sup>2</sup>
	PROBAU Münchener Rauputz with PROBAU Edelputzgrundierung	x	
	PROBAU Scheibenputz with PROBAU Edelputzgrundierung	x	
	PROBAU Strukturalputz with PROBAU Edelputzgrundierung	x	
	PROBAU Marmorputz with PROBAU Edelputzgrundierung	x	
	PROBAU Kratzputz with PROBAU Edelputzgrundierung	x	
	PROBAU Silikonharzputz with PROBAU Edelputzgrundierung	x	
	PROBAU Siloxanputz with PROBAU Edelputzgrundierung	x	
	PROBAU Kunstharzputz with PROBAU Edelputzgrundierung	x	
	PROBAU Silikatputz with PROBAU Silikatverdünner	x	



English translation prepared by DIBt

### 3.3.2 Hygrothermal behaviour (ETAG 004 - clause 5.1.3.2)

Pass (without defects)

### 3.3.3 Impact resistance (ETAG 004 – clause 5.1.3.3)

The verified resistance to hard body impact and to perforation of the ETICS results in the classification into category II.

### 3.3.4 Water vapour permeability (ETAG 004 – clause 5.1.3.4)

Rendering system: Base coats with finishing coat and compatible key coat hereafter indicated:	Equivalent air thickness $s_d$
PROBAU Münchner Rauputz with PROBAU Edelputzgrundierung	$\leq 1.0$ m (Test result obtained with particle size 3 mm: 0.1 m)
PROBAU Scheibenputz with PROBAU Edelputzgrundierung	$\leq 1.0$ m (Test result obtained with particle size 3 mm: 0.1 m)
PROBAU Marmorputz with PROBAU Edelputzgrundierung	$\leq 1.0$ m (Test result obtained with particle size 2.5 mm: 0.1 m)
PROBAU Strukturalputz with PROBAU Edelputzgrundierung	$\leq 1.0$ m (Test result obtained with particle size 3 mm: 0.1 m)
PROBAU Kratzputz with PROBAU Edelputzgrundierung	$\leq 1.0$ m (Test result obtained with particle size 3 mm: 0.1 m)
PROBAU Silikonharzputz with PROBAU Edelputzgrundierung	$\leq 1.0$ m (Test result obtained with particle size 2 mm: 0.2 m)
PROBAU Siloxanputz with PROBAU Edelputzgrundierung	$\leq 1.0$ m (Test result obtained with particle size 2 mm: 0.2 m)
PROBAU Kunstharzputz with PROBAU Edelputzgrundierung	$\leq 1.0$ m (Test result obtained with particle size 2 mm: 0.4 m)
PROBAU Silikatputz with PROBAU Silikatverdünner	$\leq 1.0$ m (Test result obtained with particle size 2 mm: 0.1 m)

### 3.3.5 Release of dangerous substances (ETAG 004 - clause 5.1.3.5, EOTA TR 034)

Essential characteristic	Performance
Release of dangerous substances	no performance assessed

## 3.4 Safety and accessibility in use (BWR 4)

### 3.4.1 Bond strength between base coat and insulation product (EPS) (ETAG 004 - clause 5.1.4.1.1)

Conditioning		
Initial state	After hygrothermal cycles	After freeze/thaw test
$\geq 0.08$ MPa	$\geq 0.08$ MPa	Test not required because freeze/thaw cycles not necessary

**3.4.2 Bond strength between adhesive and substrate resp. insulation product (EPS) (ETAG 004 - clauses 5.1.4.1.2 and 5.1.4.1.3)**

Adhesive	Substrate resp. insulation product	Conditioning		
		Initial state	2 d immersion in water and 2 h drying	2 d immersion in water and 7 d drying
PROBAU Klebe- und Armierungsmörtel grau/weiß	Concrete	≥ 0.25 MPa	≥ 0.08 MPa	≥ 0.25 MPa
	EPS	≥ 0.08 MPa	≥ 0.03 MPa	≥ 0.08 MPa
PROBAU WDVS-Spachtel	Concrete	≥ 0.25 MPa	≥ 0.08 MPa	≥ 0.25 MPa
	EPS	≥ 0.08 MPa	≥ 0.03 MPa	≥ 0.08 MPa
PROBAU Klebe- und Armierungsmörtel MG II	Concrete	≥ 0.25 MPa	≥ 0.08 MPa	≥ 0.25 MPa
	EPS	≥ 0.08 MPa	≥ 0.03 MPa	≥ 0.08 MPa

Bonded surface:

For bonded ETICS the calculated minimal bonded surface area, according to ETAG 004, clause 6.1.4.1.3 is 40 %.

**3.4.3 Bond strength after ageing (ETAG 004 – Abschnitt 5.1.4.2):**

<b>Rendering system:</b> Base coats with finishing coat and compatible key coat hereafter indicated:	PROBAU Münchner Rauputz with PROBAU Edelputzgrundierung	≥ 0.08 MPa
	PROBAU Scheibenputz with PROBAU Edelputzgrundierung	
	PROBAU Marmorputz with PROBAU Edelputzgrundierung	
	PROBAU Strukturalputz with PROBAU Edelputzgrundierung	
	PROBAU Kratzputz with PROBAU Edelputzgrundierung	
	PROBAU Silikonharzputz with PROBAU Edelputzgrundierung	
	PROBAU Siloxanputz with PROBAU Edelputzgrundierung	
	PROBAU Kunstharzputz with PROBAU Edelputzgrundierung	
	PROBAU Silikatputz with PROBAU Silikatverdünner	

English translation prepared by DIBt

### 3.4.4 Fixing strength (displacement test) (ETAG 004 - clause 5.1.4.2)

Test not required therefore no limitation of ETICS length required

### 3.4.5 Wind load resistance (ETAG 004 - clause 5.1.4.3)

The following failure loads only apply to the listed combination of component characteristics and the characteristics of the insulation product given in annex 1.

#### 3.4.5.1 Safety in use of mechanically fixed ETICS using profiles

Characteristics of the EPS (standard EPS)	Dimensions	500 mm x 500 mm	
	Thickness	≥ 60 mm	
	<b>Tensile strength perpendicular to the faces</b>	<b>≥ 150 kPa</b>	
	Shear modulus	≥ 1.0 N/mm <sup>2</sup>	
Failure loads [N/panel] (Static Foam Block Test)	Horizontal profiles fixed every 30 cm and 49.4 cm long vertical connection profiles	Minimal:	950
		Average:	1010

#### 3.4.5.2 Safety in use of mechanically fixed ETICS using anchors

Apply to all anchors listed in the clause 1.2 mounted on the insulation panels surface				
Characteristics of the EPS (standard EPS)	Thickness		≥ 60 mm	
	<b>Tensile strength perpendicular to the faces</b>		<b>≥ 100 kPa</b>	
	Shear modulus		≥ 1.0 N/mm <sup>2</sup>	
Plate diameter of anchor			Ø 60 mm	Ø 90 mm
Failure loads [N]	Anchors not placed at the panel joints (Static Foam Block Test)	R <sub>panel</sub>	Minimal: 510 Average: 520	Minimal: 720 Average: 730
	Anchors placed at the panel joints (Pull-through test)	R <sub>joint</sub>	Minimal: 400 Average: 430	Minimal: 430 Average: 470

Apply to all anchors listed in the clause 1.2 mounted on the insulation panels surface				
Characteristics of the EPS (elastified EPS)	Thickness		≥ 60 mm	
	<b>Tensile strength perpendicular to the faces</b>		<b>≥ 80 kPa</b>	
	Shear modulus		≥ 0.3 N/mm <sup>2</sup>	
Plate diameter of anchor			Ø 60 mm	
Failure loads [N]	Anchors not placed at the panel joints (Static Foam Block Test)	R <sub>panel</sub>	Minimal: 350 Average: 360	
	Anchors placed at the panel joints (Pull-through test)	R <sub>joint</sub>	Minimal: 300 Average: 310	

The failure loads specified above for a plate diameter of anchor of 60 mm apply to the following anchors with deep mounting but only on the following conditions of installation:

Anchor	Thickness of the EPS [d]	Conditions of installation*
ejothem STR U, ejothem STR U 2G (ETA-04/0023)	100 mm > d ≥ 80 mm (for standard and elastified EPS)	– Maximum installation depth of the anchor plate: 15 mm (△ thickness of insulation cover) – Maximum depth of die: 5 mm
	≥ 100 mm (for standard and elastified EPS)	– Maximum installation depth of the anchor plate: 15 mm (△ thickness of insulation cover) – Maximum depth of die: 20 mm
* According to the appropriate ETA of anchor		

### 3.4.6 Render strip tensile test (ETAG 004 – clause 5.5.4.1)

The average value of crack width of the base coat "PROBAU Klebe- und Armierungsmörtel grau" reinforced with the glass fibre mesh "PROBAU Armierungsgewebe F" measured at a render strain value of 1 % is about 0.18 mm.

For the reinforced base coat "PROBAU Klebe- und Armierungsmörtel weiß" no performance was assessed.

### 3.5 Protection against noise (BWR 5)

For the sound insulation properties of the ETICS no performance was assessed.

### 3.6 Energy economy and heat retention (BWR 6)

#### 3.6.1 Thermal resistance

The nominal value of the additional thermal resistance R provided by the ETICS to the substrate wall is calculated in accordance with EN ISO 6946:2007 from the nominal value of the insulation product's thermal resistance  $R_D$  given accompanied to the CE marking, and from the thermal resistance of the rendering system  $R_{render}$  which is about 0.02 (m<sup>2</sup> · K)/W.

$$R = R_D + R_{render}$$

The thermal bridges caused by anchors and profiles increases the thermal transmittance U. This influence had to take into account according to EN ISO 6946:2007.

$$U_c = U + \chi_p \cdot n \text{ (W/ (m}^2 \cdot \text{K))}$$

Where:  $U_c$ : corrected thermal transmittance [W/(m<sup>2</sup> · K)]

n: number of anchors per m<sup>2</sup>

$\chi_p$ : local influence of thermal bridge caused by an anchor. The values listed below can be taken into account if not specified in the anchor's ETA:

$\chi_p = 0.004$  W/K for anchors with a galvanized steel screw with the head covered by a plastic material

$\chi_p = 0.002$  W/K for anchors with a stainless steel screw covered by plastic anchors and for anchors with an air gap at the head of the screw

The thermal bridges caused by profiles are negligible.

English translation prepared by DIBt

**4 Assessment and verification of constancy of performance (AVCP) system applied, with reference to its legal base**

According to the European Commission decision 97/556/EC amended by the European Commission decision 2001/596/EC, the assessment and verification of constancy of performance system (AVCP) applies suitable following table (see Annex V to Regulation (EU) No 305/2011).

Product	Intended use	Levels or classes (Reaction to fire)	Systems
"PROBAU - WDV-System"	in external wall subject to fire regulations	A1 <sup>(1)</sup> , A2 <sup>(1)</sup> , B <sup>(1)</sup> , C <sup>(1)</sup>	1
		A1 <sup>(2)</sup> , A2 <sup>(2)</sup> , B <sup>(2)</sup> , C <sup>(2)</sup> , D, E, (A1 to E) <sup>(3)</sup> , F	2+
	in external wall not subject to fire regulations	any	2+
<sup>(1)</sup> Products/materials for which a clearly identifiable stage in the production process results in an improvement of the reaction to fire classification (e.g. an addition of fire retardants or a limiting of organic material) <sup>(2)</sup> Products/materials not covered by footnote (1) <sup>(3)</sup> Products/materials that do not require to be tested for reaction to fire (e.g. products/materials of Classes A1 according to Commission Decision 96/603/EC)			

**5 Technical details necessary for the implementation of the AVCP system, as provided for in the applicable European Assessment Document (EAD)**

Technical details necessary for the implementation of the AVCP system are laid down in the control plan deposited at Deutsches Institut für Bautechnik.

Issued in Berlin on 14 March 2018 by Deutsches Institut für Bautechnik

Dirk Brandenburger  
Head of Department

*beglaubigt:*  
Ruppert

**European Technical Assessment**  
**ETA-07/0284**

English translation prepared by DIBt

Page 14 of 18 | 14 March 2018

**Annexes:**

Annex 1: Thermal insulation product characteristics

Annex 2: Anchors

Annex 3: Profiles

Annex 4: Reinforcement

**Annex 1: Thermal insulation product characteristics**

Factory-prefabricated, uncoated panels made of expanded polystyrene (EPS) to EN 13163:2015 shall be used, having the description and characteristics defined in the Table below.

Description and characteristics	For bonded ETICS	For mechanically fixed ETICS	
		with anchors and supplementary adhesive	with profiles and supplementary adhesive****
Reaction to fire; EN 13501-1:2007	Class E*		
Thermal resistance [(m <sup>2</sup> ·K)/W]	Defined in the CE marking in reference to EN 13163:2015		
<b>Tolerances</b>			
Length; EN 822:2013	± 0.6 % or ± 3 mm whichever gives the greatest numerical tolerance (class L3)		
Width [mm]; EN 822:2013	± 2 (class W2)		
Thickness [mm]; EN 823:2013	± 1 (class T1)		
Squareness [mm/m]; EN 824:2013	± 2 (class S2)		
Flatness [mm/m]; EN 825:2013	5 (class P5)		
<b>Dimensional stability under</b>			
- laboratory conditions [%]; EN 1603:2013	± 0.2 (class DS(N)2)		
- specified temperature and humidity conditions [%]; EN 1604:2013	2 (level DS(70,-)2 or level DS(70,-)1)		
Water absorption (long term partial immersion) [kg/m <sup>2</sup> ]; EN 12087:2013	W <sub>ip</sub> ≤ 0.5		
Water vapour diffusion resistance factor; EN 12086:2013	μ = 20 – 78		
Tensile strength perpendicular to the faces in dry conditions** [kPa]; EN 1607:2013			
- standard EPS	σ <sub>mt</sub> ≥ 80	σ <sub>mt</sub> ≥ 100	σ <sub>mt</sub> ≥ 150
- elastified EPS***	σ <sub>mt</sub> ≥ 80	σ <sub>mt</sub> ≥ 80	not used
Bending strength** [kPa]; EN 12089:2013	σ <sub>b</sub> ≥ 50		
Apparent density [kg/m <sup>3</sup> ]; EN 1602:2013	ρ <sub>a</sub> ≤ 30		
Shear strength** [kPa]; EN 12090:2013	20 ≤ f <sub>tk</sub> ≤ 170		
Shear modulus [MPa]; EN 12090:2013	1.0 ≤ G <sub>m</sub> ≤ 3.8		
- standard EPS	1.0 ≤ G <sub>m</sub> ≤ 3.8		
- elastified EPS***	0.3 ≤ G <sub>m</sub> ≤ 1.0	0.3 ≤ G <sub>m</sub> ≤ 1.0	not used
Testing of characteristics: see EN 13163:2015.			
* See the conditions of clause 3.2 for the EPS.			
** Minimal value of all single values			
*** Elastified EPS is made from standard EPS by short time high load pressing to reduce the dynamic stiffness. The protection against noise of the entire wall is improved by the use of elastified EPS related to an ETICS with standard EPS.			
**** Thermal insulation materials for mechanically fixed ETICS with profiles must circumferentially at the edges, 24 mm from the inner surface, get an approx. 3 mm wide and 13 to 18 mm deep groove cut-in at the factory.			

## Annex 2: Anchors

All anchors with ETA according to EAD330196-00-0604<sup>1</sup> with characteristics having the description below shall be used in the mechanically fixed ETICS:

- plate diameter of anchor  $\geq 60$  mm resp.  $\geq 90$  mm
- plate stiffness  $\geq 0.3$  kN/mm
- load resistance of the anchor plate  $\geq 1.0$  kN

These characteristics and the characteristic tension resistance of the anchors shall be taken from the corresponding ETA.

The anchors listed in the Table in clause 1.2 with reference to the respective ETA shall be used in the mechanically fixed ETICS with profiles for fixing the horizontal profiles.

Trade name	ETA-number
WS 8 L	ETA-02/0019
WS 8 N	ETA-03/0019
ejothem SDK U	ETA-04/0023
SDF-K plus	ETA-04/0064
ejothem NK U	ETA-05/0009



### Annex 3: Profiles

Polyvinyl chloride (PVC) profiles, PVC-U, EGL, 082-05-T33 to EN ISO 1163-1:1999 are to be used in the mechanically fixed ETICS with profiles.

The Pull-through resistance of fixings from profiles is  $\geq 500$  N.

#### Horizontal profile – "PROBAU Halteleiste PVC" (dimensions in millimetres)

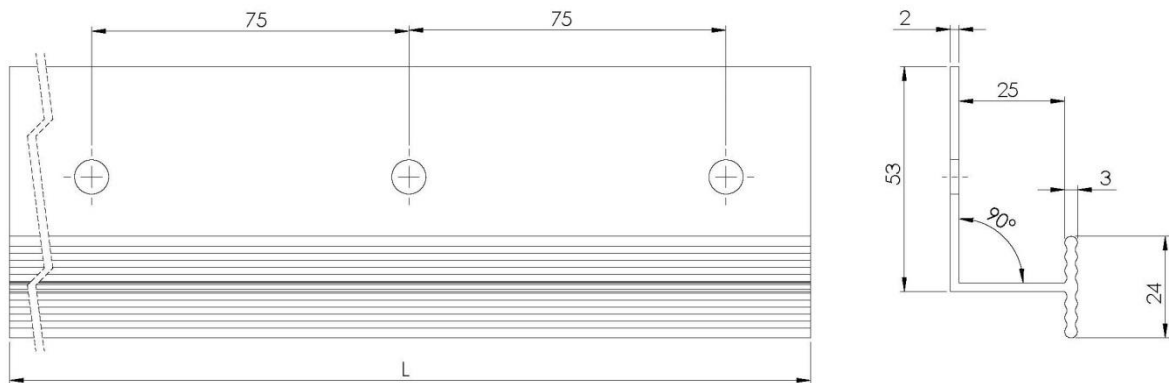

#### Vertical connection profile – "PROBAU Verbindungsleiste PVC" (dimensions in millimetres)

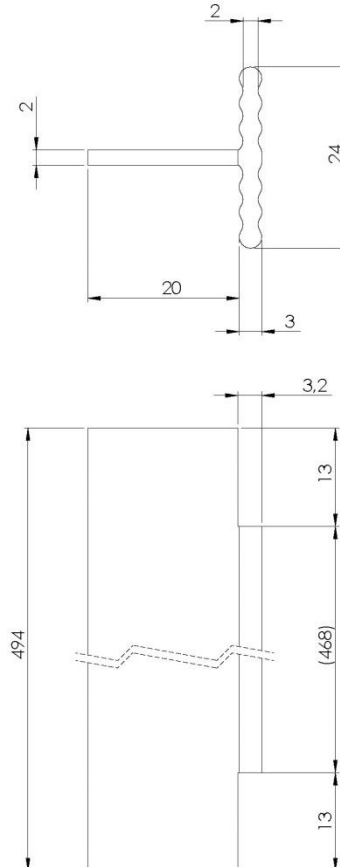

**Annex 4: Reinforcement (glass fibre mesh)**

Characteristics (alkali resistance): Pass

	Description	Residual strength after ageing [N/mm]	Relative residual strength after ageing, of the strength in the as-delivered state [%]
"PROBAU Armierungsgewebe F"	Alkali- and slide-resistant glass fibre mesh with mass per unit area of about 160 g/m <sup>2</sup> and mesh size of about 4,0 mm x 4,0mm	≥ 20	≥ 50