

Approval body for construction products
and types of construction

Bautechnisches Prüfamt

An institution established by the Federal and
Laender Governments



European Technical Assessment

ETA-08/0345
of 27 February 2018

English translation prepared by DIBt - Original version in German language

General Part

Technical Assessment Body issuing the
European Technical Assessment:

Deutsches Institut für Bautechnik

Trade name of the construction product

TOX Drop-in Anchor E / ES

Product family
to which the construction product belongs

Deformation-controlled expansion anchor for
multiple use for non-structural applications in concrete

Manufacturer

TOX-Dübel-Technik GmbH
Brunnenstraße 31
72505 Krauchenwies-Ablach
DEUTSCHLAND

Manufacturing plant

TOX Werk 10, Deutschland

This European Technical Assessment
contains

20 pages including 3 annexes which form an integral part
of this assessment

This European Technical Assessment is
issued in accordance with Regulation (EU)
No 305/2011, on the basis of

ETAG 001 Part 6: "Anchors for multiple use for non-
structural applications", January 2011,
used as EAD according to Article 66 Paragraph 3 of
Regulation (EU) No 305/2011.

The European Technical Assessment is issued by the Technical Assessment Body in its official language. Translations of this European Technical Assessment in other languages shall fully correspond to the original issued document and shall be identified as such.

Communication of this European Technical Assessment, including transmission by electronic means, shall be in full. However, partial reproduction may only be made with the written consent of the issuing Technical Assessment Body. Any partial reproduction shall be identified as such.

This European Technical Assessment may be withdrawn by the issuing Technical Assessment Body, in particular pursuant to information by the Commission in accordance with Article 25(3) of Regulation (EU) No 305/2011.

Specific Part

1 Technical description of the product

The TOX Drop-in Anchor E / ES is an anchor made of zinc-plated steel, of stainless steel or high corrosion resistant steel which is placed into a drilled hole and anchored by deformation-controlled expansion.

The product description is given in Annex A.

2 Specification of the intended use in accordance with the applicable European Assessment Document

The performances given in Section 3 are only valid if the anchor is used in compliance with the specifications and conditions given in Annex B.

The verifications and assessment methods on which this European Technical Assessment is based lead to the assumption of a working life of the anchor of at least 50 years. The indications given on the working life cannot be interpreted as a guarantee given by the producer, but are to be regarded only as a means for choosing the right products in relation to the expected economically reasonable working life of the works.

3 Performance of the product and references to the methods used for its assessment

3.1 Mechanical resistance and stability (BWR 1)

The essential characteristics regarding Mechanical resistance and stability are included under the Basic Works Requirement Safety in use.

3.2 Safety in case of fire (BWR 2)

Essential characteristic	Performance
Reaction to fire	Anchorage satisfy requirements for Class A1
Resistance to fire	See Annex C 4 to C 5

3.3 Safety in use (BWR 4)

Essential characteristic	Performance
Characteristic values for static and quasi- static actions	See Annex C 1 to C 3

4 Assessment and verification of constancy of performance (AVCP) system applied, with reference to its legal base

In accordance with guideline for European technical approval ETAG 001, January 2011 used as European Assessment Document (EAD) according to Article 66 Paragraph 3 of Regulation (EU) No 305/2011 the applicable European legal act is: [97/161/EC].

The system to be applied is: 2+

English translation prepared by DIBt

5 Technical details necessary for the implementation of the AVCP system, as provided for in the applicable European Assessment Document

Technical details necessary for the implementation of the AVCP system are laid down in the control plan deposited with Deutsches Institut für Bautechnik.

Issued in Berlin on 27 February 2018 by Deutsches Institut für Bautechnik

Dr.-Ing. Lars Eckfeldt
p.p. Head of Department

beglaubigt:
Baderschneider

TOX Drop-in Anchor E / ES

Anchorage depth $h_{ef} = 25$ mm (zinc plated)



Anchorage depth $h_{ef} \geq 30$ mm (zinc plated, A4 or HCR)

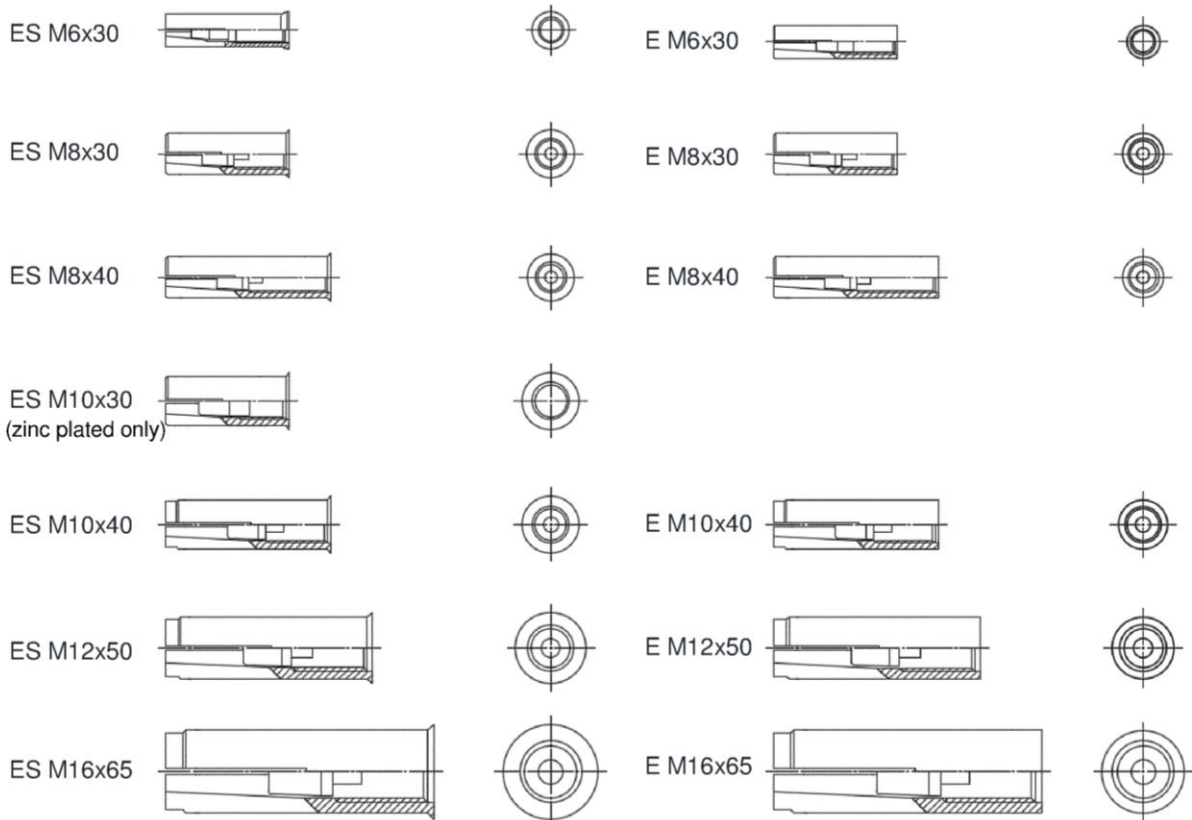

TOX Drop-in Anchor E / ES

Product description
Anchor size

Annex A1

Installation situation in concrete

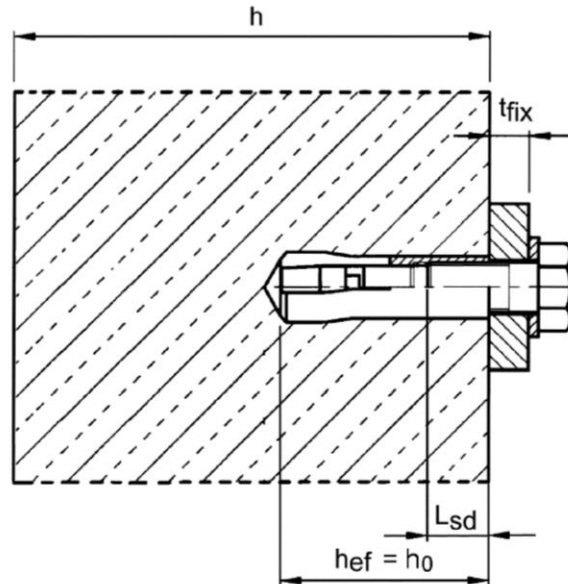

Installation situation in precast pre-stressed hollow core slabs for $h_{ef} = 25 \text{ mm}$

$$w / e \leq 4,2$$

- w core width
- e web thickness
- d_b flange thickness
 $\geq 35 \text{ mm}$ (or $\geq 30 \text{ mm}$, see Annex C3)
- h_{ef} embedment depth
- t_{fix} thickness of fixture
- c edge distance

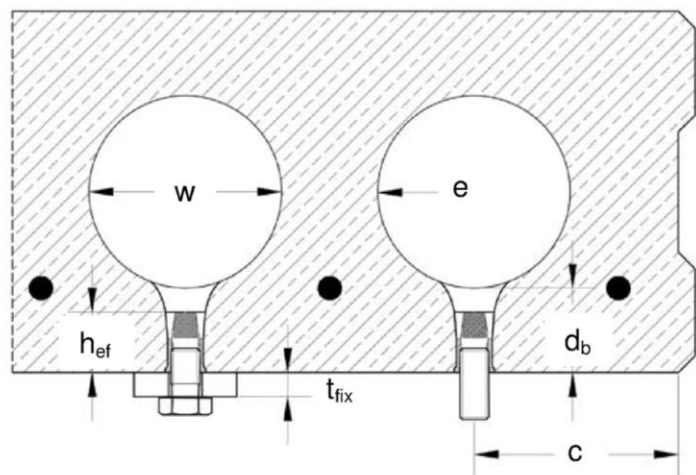

TOX Drop-in Anchor E / ES

Product description
Installation situation

Annex A2

Table A1: Designation and Material TOX Drop-in Anchor E / ES

Part	Designation	Steel, zinc plated	Stainless steel A4	High corrosion resistant steel HCR
1	Anchor sleeve	Cold formed or machining steel, zinc plated, EN ISO 4042:1999	Stainless steel (e.g. 1.4401, 1.4404, 1.4571, 1.4362) EN 10088:2014, Property class 70 EN ISO 3506:2010	Stainless steel, 1.4529, 1.4565, EN 10088:2014, Property class 70 EN ISO 3506:2010
2	Cone	Cold formed or machining steel	Stainless steel (e.g. 1.4401, 1.4404, 1.4571, 1.4362) EN 10088:2014	

Requirements on the fastening screw or the threaded rod and nut according to the engineering documents:

- Minimum screw-in depth L_{sdmin} see Table B1 and B2
- The length of screw or the threaded rod shall be determined depending on the thickness of fixture t_{fix} , available thread length L_{th} (= maximum screw-in depth) and the minimum screw-in depth L_{sdmin} .
- $A_5 > 8\%$ Ductility

Steel, zinc plated

- Property class 4.6 / 4.8 / 5.6 / 5.8 or 8.8 according to EN ISO 898-1:2013 or EN ISO 898-2:2012

Stainless steel A4

- Material 1.4401; 1.4404; 1.4578; 1.4571; 1.4439; 1.4362 EN 10088:2014
- Property class 70 or 80 according to EN ISO 3506:2010

High corrosion resistant steel (HCR)

- Material 1.4529; 1.4565, according to EN 10088:2014
- Property class 70 or 80 according to EN ISO 3506:2010

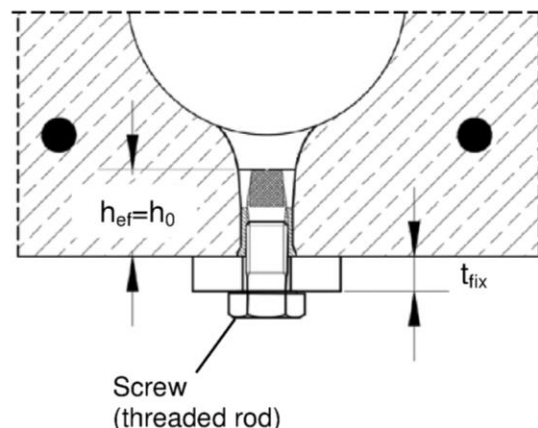

TOX Drop-in Anchor E / ES

Product description

Material E / ES and requirements on the fastening screw or the threaded rod and nut

Annex A3

Anchor sleeve

Anchor version without shoulder (E)

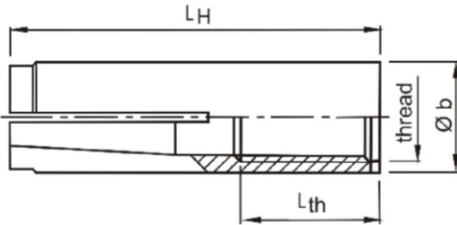

Marking: see Table A2

e.g.: \diamond E M8x40

\diamond Identifying mark of manufacturing plant
E Anchor identity (version without shoulder)
ES Anchor identity (version with shoulder)
M8 Size of thread
40 Anchorage depth

Anchor version with shoulder (ES)

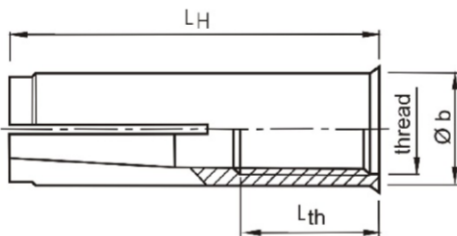

A4 additional marking
of stainless steel A4

HCR additional marking of
high corrosion resistant steel

Cone

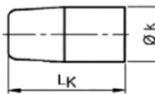

Size M6x25 to M12x25,
M6x30 and M10x30

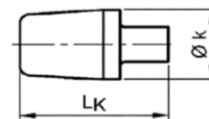

Remaining sizes

Table A2: Dimensions and marking

Anchor size	Anchor sleeve				Cone		Marking		
	thread	Ø b	L _H	L _{th}	Ø k	L _k	version E	version ES	alternatively
M6x25	M6	8	25	12	4,6	9	-	\diamond ES M6x25	-
M6x30	M6	8	30	13	5,0	13	\diamond E M6x30	\diamond ES M6x30	\diamond E M6
M8x25	M8	10	25	12	6,3	9	-	\diamond ES M8x25	-
M8x30	M8	10	30	13	6,5	12	\diamond E M8x30	\diamond ES M8x30	\diamond E M8
M8x40	M8	10	40	20	6,5	12	\diamond E M8x40	\diamond ES M8x40	\diamond E M8x40
M10x25	M10	12	25	12	8,2	9	-	\diamond ES M10x25	-
M10x30	M10	12	30	12	8,2	12	-	\diamond ES M10x30	\diamond E M10x30
M10x40	M10	12	40	15	8,2	16	\diamond E M10x40	\diamond ES M10x40	\diamond E M10
M12x25	M12	15	25	12	9,7	10,7	-	\diamond ES M12x25	-
M12x50	M12	15	50	18	10,3	20	\diamond E M12x50	\diamond ES M12x50	\diamond E M12
M16x65	M16	19,7	65	23	13,8	29	\diamond E M16x65	\diamond ES M16x65	\diamond E M16

Dimensions in mm

TOX Drop-in Anchor E / ES

Product description
Dimensions and marking

Annex A4

Setting tool for marking

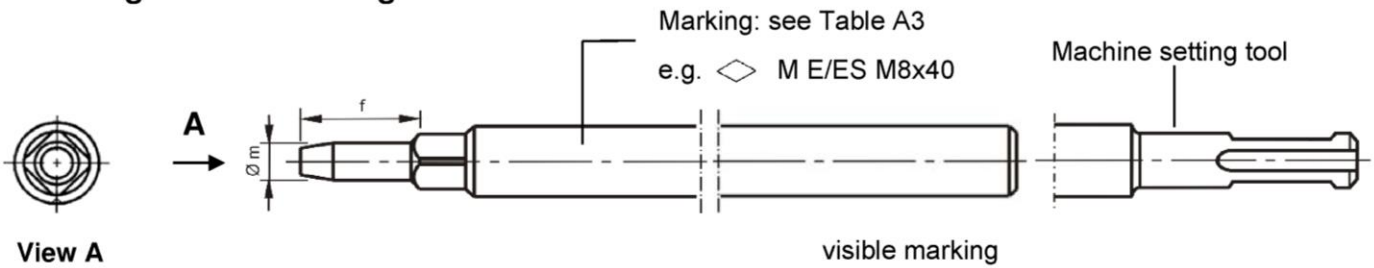

Verification of correct installation with setting tool for marking
The setting tool leaves a visible marking after correct installation.

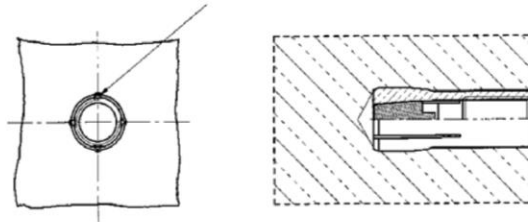

Setting tool

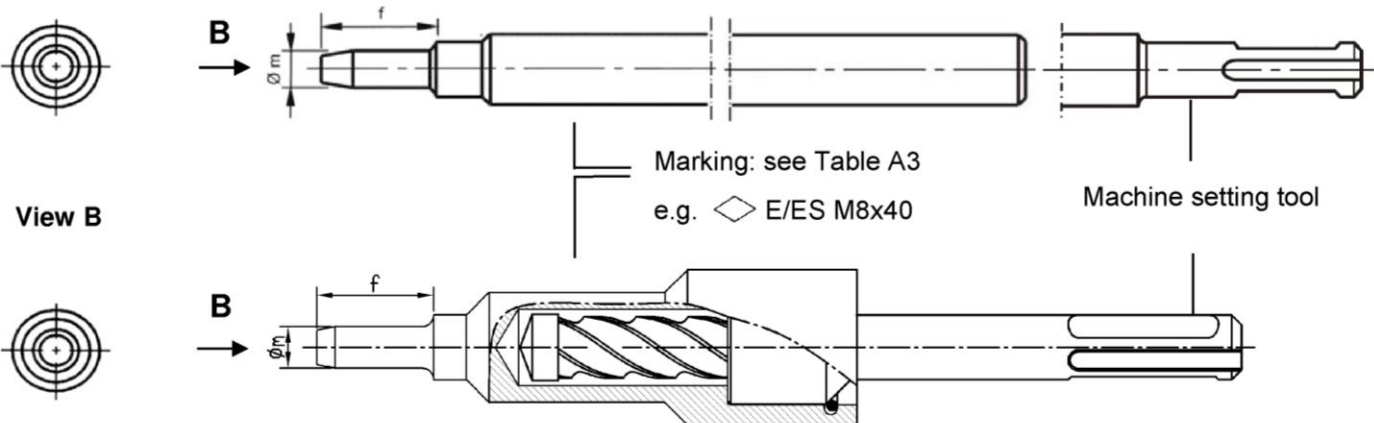

Table A3: Dimensions and marking of setting tools

Anchor size	$\varnothing m$	f	Setting tool for marking		Setting tool	
			Marking	alternatively	Marking	alternatively
M6x25	4,9	17	$\diamond M ES M6x25$	-	$\diamond ES M6x25$	-
M6x30	4,9	17	$\diamond M E/ES M6x30$	$\diamond M E M6$	$\diamond E/ES M6x30$	$\diamond E M6$
M8x25	6,4	17	$\diamond M ES M8x25$	-	$\diamond ES M8x25$	-
M8x30	6,4	18	$\diamond M E/ES M8x30$	$\diamond M E M8$	$\diamond E/ES M8x30$	$\diamond E M8$
M8x40	6,4	28	$\diamond M E/ES M8x40$	$\diamond M E M8x40$	$\diamond E/ES M8x40$	$\diamond E M8x40$
M10x25	8,0	18	$\diamond M ES M10x25$	-	$\diamond ES M10x25$	-
M10x30	8,0	18	$\diamond M ES M10x30$	$\diamond M E M10x30$	$\diamond ES M10x30$	$\diamond E M10x30$
M10x40	8,0	24	$\diamond M E/ES M10x40$	$\diamond M E M10$	$\diamond E/ES M10x40$	$\diamond E M10$
M12x25	10,0	15,5	$\diamond M ES M12x25$	-	$\diamond ES M12x25$	-
M12x50	10,0	30	$\diamond M E/ES M12x50$	$\diamond M E M12$	$\diamond E/ES M12x50$	$\diamond E M12$
M16x65	13,5	36	$\diamond M E/ES M16x65$	$\diamond M E M16$	$\diamond E/ES M16x65$	$\diamond E M16$

Dimensions in mm

TOX Drop-in Anchor E / ES

Product description
Setting tools, dimensions and marking

Annex A5

Specifications of intended use

TOX Drop-in Anchor							
Anchorage depth $h_{ef} \geq 30$ mm	M6x30	M8x30	M8x40	M10x30	M10x40	M12x50	M16x65
Steel, zinc plated				✓			
Stainless steel A4 and high corrosion resistant steel HCR		✓		-		✓	
Static and quasi-static loads				✓			
Fire exposure				✓			
Cracked and uncracked concrete				✓			
Solid concrete C20/25 to C50/60				✓			

Anchorage depth $h_{ef} = 25$ mm	M6x25	M8x25	M10x25	M12x25
Steel, zinc plated		✓		
Stainless steel A4 and high corrosion resistant steel HCR		-		
Static and quasi-static loads		✓		
Fire exposure (solid concrete, C20/25 to C50/60)		✓		
Cracked and uncracked concrete		✓		
Solid concrete C12/15 to C50/60		✓		
Precast pre-stressed hollow core slabs (C30/37 to C50/60)		✓		

Base materials:

- reinforced or unreinforced normal weight concrete according to EN 206-1:2000

Use conditions:

- Structures subject to dry internal conditions (zinc plated steel, stainless steel or high corrosion resistant steel).
- Structures subject to external atmospheric exposure (including industrial and marine environment) or exposure to permanently damp internal condition, if no particular aggressive conditions exist (stainless steel or high corrosion resistant steel).
- Structures subject to external atmospheric exposure and to permanently damp internal condition, if other particular aggressive conditions (high corrosion resistant steel).

Note: Particular aggressive conditions are e.g. permanent, alternating immersion in seawater or the splash zone of seawater, chloride atmosphere of indoor pools or atmosphere with extreme chemical pollution (e.g. in desulphurization plants or road tunnels where de-icing materials are used.)

TOX Drop-in Anchor E / ES

Intended use
Specifications

Annex B1

Specifications of intended use

Design:

- Anchorages are designed under the responsibility of an engineer experienced in anchorages and concrete work.
- Verifiable calculation notes and drawings are prepared taking account of the loads to be anchored. The position of the anchor is indicated on the design drawings (e.g. position of the anchor relative to reinforcement or to supports, etc.).
- The strength class and the length of the fastening screw or threaded rod shall be defined by the designing engineer
- Anchorages under static or quasi-static actions for multiple use for non-structural applications are designed in accordance with:
 - ETAG 001, Annex C, design method B, Edition August 2010 or
 - CEN/TS 1992-4:2009, design method B
- Anchorages under static or quasi-static actions for precast pre-stressed hollow core slabs:
 - ETAG 001, Annex C, design method C, Edition August 2010.
 - CEN/TS 1992-4:2009, design method C
- Anchorages under fire exposure are designed in accordance with:
 - ETAG 001, Annex C, design method B, Edition August 2010 and EOTA Technical Report TR 020, Edition May 2004 or
 - CEN/TS 1992-4:2009, Annex D
 - It must be ensured that local spalling of the concrete cover does not occur.

Installation:

- Anchor installation carried out by appropriately qualified personnel and under the supervision of the person responsible for technical matters of the site,
- Anchor installation in accordance with the manufacturer's specifications and drawings and using the appropriate tools,
- Drill hole by hammer drilling only (use of vacuum drill bits is admissible),
- Positioning of the drill holes without damaging the reinforcement.

TOX Drop-in Anchor E / ES

Intended use
Specifications

Annex B2

Table B1: Installation parameters for $h_{ef} \geq 30$ mm

Anchor size			M6x30	M8x30	M8x40	M10x30	M10x40	M12x50	M16x65
Depth of drill hole	$h_0 =$	[mm]	30	30	40	30	40	50	65
Drill hole diameter	$d_0 =$	[mm]	8	10	10	12	12	15	20
Cutting diameter of drill bit	$d_{cut} \leq$	[mm]	8,45	10,45	10,45	12,5	12,5	15,5	20,55
Max. recommended installation torque	$T_{inst} \leq$	[Nm]	4	8	8	15	15	35	60
Diameter of clearance hole in the fixture	$d_f \leq$	[mm]	7	9	9	12	12	14	18
Available thread length	L_{th}	[mm]	13	13	20	12	15	18	23
Minimum screw-in depth	L_{sdmin}	[mm]	7	9	9	10	11	13	18
Steel, zinc plated									
Minimum thickness of member	h_{min}	[mm]	100	100	100	120	120	130	160
Minimum spacing	s_{min}	[mm]	55	60	80	100	100	120	150
Minimum distance	c_{min}	[mm]	95	95	95	115	135	165	200
Stainless steel A4, HCR									
Minimum thickness of member	h_{min}	[mm]	100	100	100	-	130	140	160
Minimum spacing	s_{min}	[mm]	50	60	80	-	100	120	150
Minimum distance	c_{min}	[mm]	80	95	95	-	135	165	200

Table B2: Installation parameters for $h_{ef} = 25$ mm

Anchor size			M6x25	M8x25	M10x25	M12x25
Depth of drill hole	$h_0 =$	[mm]	25	25	25	25
Drill hole diameter	$d_0 =$	[mm]	8	10	12	15
Cutting diameter of drill bit	$d_{cut} \leq$	[mm]	8,45	10,45	12,5	15,5
Max. recommended installation torque	$T_{inst} \leq$	[Nm]	4	8	15	35
Diameter of clearance hole in the fixture	$d_f \leq$	[mm]	7	9	12	14
Available thread length	L_{th}	[mm]	12	12	12	12
Minimum screw-in depth	L_{sdmin}	[mm]	6	8	10	12
Minimum thickness of member	$h_{min,1}$	[mm]	80			
Minimum spacing	s_{min}	[mm]	30	70	70	100
Minimum edge distance	c_{min}	[mm]	60	100	100	130
Standard thickness of member	$h_{min,2}$	[mm]	100			
Minimum spacing	s_{min}	[mm]	30	50	60	100
Minimum edge distance	c_{min}	[mm]	60	100	100	110
Installation in precast pre-stressed hollow core slabs C30/37 to C50/60						
Spacing	s_{min}	[mm]	200			
Edge distance	c_{min}	[mm]	150			

TOX Drop-in Anchor E / ES

Intended use
Installation parameters

Annex B3

English translation prepared by DIBt

Admissible anchor positions in precast pre-stressed hollow core slabs ($w / e \leq 4,2$)

core distance:
 $l_c \geq 100$ mm

pre-stressing steel distance:
 $l_p \geq 100$ mm

distance between anchor position and pre-stressing steel:
 $a_p \geq 50$ mm

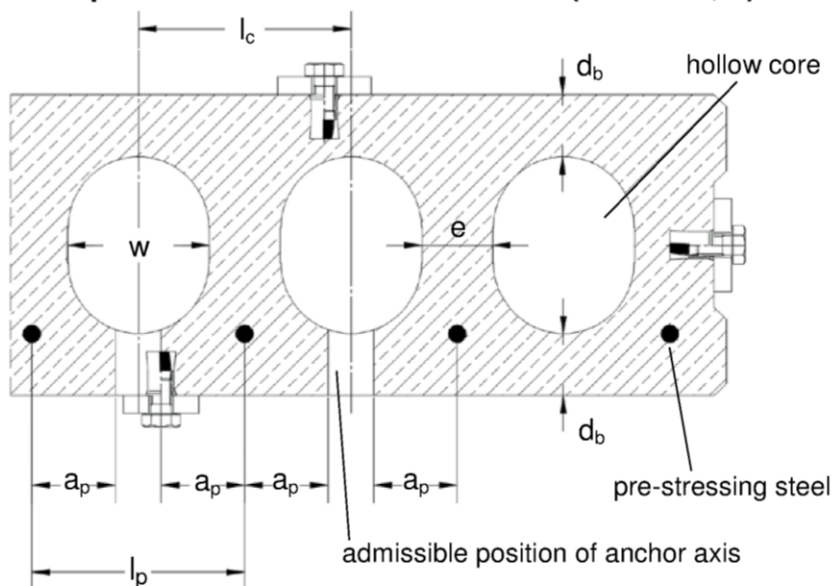

Minimum spacing and edge distance of anchors and distance between anchor groups in precast pre-stressed hollow core slabs

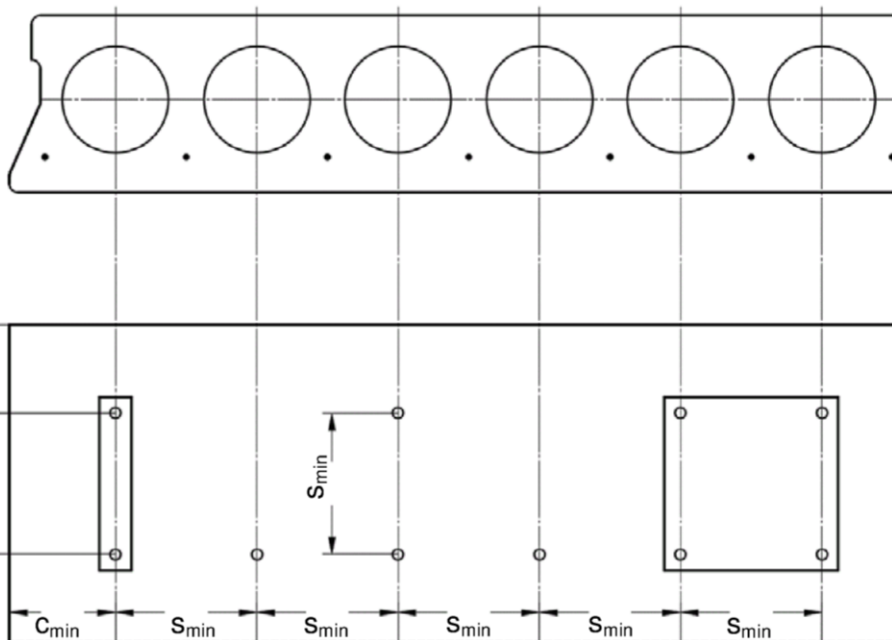

Minimum edge distance
 $C_{min} \geq 150$ mm

Minimum anchor spacing
 $S_{min} \geq 200$ mm

electronic copy of the eta by dibt: eta-08/0345

TOX Drop-in Anchor E / ES

Intended use
Installation in precast pre-stressed hollow core slabs

Annex B4

Installation instructions for solid concrete slabs

1		<p>Drill hole perpendicular to concrete surface. When using vacuum drill bit proceed with step 3.</p>
2		<p>Blow out dust. Alternatively vacuum-clean down to the bottom of the hole.</p>
3		<p>Drive in anchor.</p>
4		<p>Drive in cone by using setting tool.</p>
5		<p>Shoulder of setting tool must fit on anchor rim.</p>
6		<p>Apply installation torque T_{inst} by using calibrated torque wrench.</p>

TOX Drop-in Anchor E / ES

Intended use
Installation instructions for solid concrete slabs

Annex B5

Installation instructions for precast pre-stressed hollow core slabs

1		Search for the position of the reinforcement.
2		Mark the position of the reinforcement and search for the other position of the reinforcement
3		Mark the positions of reinforcement.
4		Drill hole while maintaining the required distances.
5		Blow out dust. Alternatively vacuum clean down to the bottom of the hole.
6		Drive in anchor.
7		Drive in cone by using setting tool.
8		Shoulder of setting tool must fit on anchor rim.
9		Apply installation torque T_{inst} by using calibrated torque wrench.

TOX Drop-in Anchor E / ES

Intended use
Installation instructions for precast pre-stressed hollow core slabs

Annex B6

Table C1: Characteristic resistance for $h_{ef} \geq 30$ mm in **solid concrete slabs**

Anchor size			M6x30	M8x30	M8x40	M10x30	M10x40	M12x50	M16x65
Load in any direction									
Characteristic resistance in concrete C20/25 to C50/60	F_{Rk}^0	[kN]	3	5	6	6	6	6	16
Partial safety factor	γ_M	[-]	1,8	2,16		2,1	2,16	1,8	1,8
Spacing	s_{cr}	[mm]	130	180	210	230	170	170	400
Edge distance	c_{cr}	[mm]	65	90	105	115	85	85	200
Shear load with lever arm, Steel zinc plated									
Characteristic resistance (Steel 4.6)	$M_{Rk,s}^0$ ¹⁾	[Nm]	6,1	15	15	30	30	52	133
Partial safety factor	γ_{Ms}	[-]	1,67						
Characteristic resistance (Steel 4.8)	$M_{Rk,s}^0$ ¹⁾	[Nm]	6,1	15	15	30	30	52	133
Partial safety factor	γ_{Ms}	[-]	1,25						
Characteristic resistance (Steel 5.6)	$M_{Rk,s}^0$ ¹⁾	[Nm]	7,6	19	19	37	37	65	166
Partial safety factor	γ_{Ms}	[-]	1,67						
Characteristic resistance (Steel 5.8)	$M_{Rk,s}^0$ ¹⁾	[Nm]	7,6	19	19	37	37	65	166
Partial safety factor	γ_{Ms}	[-]	1,25						
Characteristic resistance (Steel 8.8)	$M_{Rk,s}^0$ ¹⁾	[Nm]	12	30	30	59	60	105	266
Partial safety factor	γ_{Ms}	[-]	1,25						
Shear load with lever arm, Stainless steel A4 / HCR									
Characteristic resistance (Property class 70)	$M_{Rk,s}^0$ ¹⁾	[Nm]	11	26	26	-	52	92	233
Partial safety factor	γ_{Ms}	[-]	1,56						
Characteristic resistance (Property class 80)	$M_{Rk,s}^0$ ¹⁾	[Nm]	12	30	30	-	60	105	266
Partial safety factor	γ_{Ms}	[-]	1,33						

¹⁾ Characteristic bending moment $M_{Rk,s}^0$ for equation (5.5) in ETAG 001, Annex C or for equation (14) in CEN/TS 1992-4-4

TOX Drop-in Anchor E / ES

Performance
Characteristic resistance for $h_{ef} \geq 30$ mm in **solid concrete**

Annex C1

Table C2: Characteristic resistance for $h_{ef} = 25$ mm in **solid concrete slabs**

Anchor size			M6x25	M8x25	M10x25	M12x25
Load in any direction						
Characteristic resistance in concrete C12/15 and C16/20	F_{Rk}^0	[kN]	2,5	2,5	3,5	3,5
Characteristic resistance in concrete C20/25 to C50/60	F_{Rk}^0	[kN]	3,5	4,0	4,5	4,5
Partial safety factor	γ_M	[-]	1,5			
Spacing	s_{cr}	[mm]	75	75	75	75
Edge distance	c_{cr}	[mm]	38	38	38	38
Shear load with lever arm						
Characteristic resistance (Steel 4.6)	$M_{Rk,s}^0$ ¹⁾	[Nm]	6,1	15	30	52
Partial safety factor	γ_{Ms}	[-]	1,67			
Characteristic resistance (Steel 4.8)	$M_{Rk,s}^0$ ¹⁾	[Nm]	6,1	15	30	52
Partial safety factor	γ_{Ms}	[-]	1,25			
Characteristic resistance (Steel 5.6)	$M_{Rk,s}^0$ ¹⁾	[Nm]	7,6	19	37	65
Partial safety factor	γ_{Ms}	[-]	1,67			
Characteristic resistance (Steel 5.8)	$M_{Rk,s}^0$ ¹⁾	[Nm]	7,6	19	37	65
Partial safety factor	γ_{Ms}	[-]	1,25			
Characteristic resistance (Steel 8.8)	$M_{Rk,s}^0$ ¹⁾	[Nm]	12	30	60	105
Partial safety factor	γ_{Ms}	[-]	1,25			

¹⁾ Characteristic bending moment $M_{Rk,s}^0$ for equation (5.5) in ETAG 001, Annex C or for equation (14) in CEN/TS 1992-4-4

TOX Drop-in Anchor E / ES

Performance
Characteristic resistance for $h_{ef} = 25$ mm in **solid concrete**

Annex C2

Table C3: Characteristic resistance for $h_{ef} = 25$ mm in precast pre-stressed hollow core slabs

Anchor size			M6x25	M8x25	M10x25	M12x25
Load in any direction						
Flange thickness	d_b	[mm]	≥ 35 (30) ¹⁾			
Characteristic resistance in precast pre-stressed hollow core slabs C30/37 to C50/60	F_{Rk}	[kN]	3,5	4,0	4,5	4,5
Partial safety factor	γ_M	[-]	1,5			
Spacing	s_{cr}	[mm]	200			
Edge distance	c_{cr}	[mm]	150			
Shear load with lever arm						
Characteristic resistance (Steel 4.6)	$M_{Rk,s}^0$ ²⁾	[Nm]	6,1	15	30	52
Partial safety factor	γ_{Ms}	[-]	1,67			
Characteristic resistance (Steel 4.8)	$M_{Rk,s}^0$ ²⁾	[Nm]	6,1	15	30	52
Partial safety factor	γ_{Ms}	[-]	1,25			
Characteristic resistance (Steel 5.6)	$M_{Rk,s}^0$ ²⁾	[Nm]	7,6	19	37	65
Partial safety factor	γ_{Ms}	[-]	1,67			
Characteristic resistance (Steel 5.8)	$M_{Rk,s}^0$ ²⁾	[Nm]	7,6	19	37	65
Partial safety factor	γ_{Ms}	[-]	1,25			
Characteristic resistance (Steel 8.8)	$M_{Rk,s}^0$ ²⁾	[Nm]	12	30	60	105
Partial safety factor	γ_{Ms}	[-]	1,25			

¹⁾ The anchor may be set in a flange thickness of 30 mm with identical characteristic loads, if the borehole cuts no hollow core.

²⁾ Characteristic bending moment $M_{Rk,s}^0$ for equation (5.5) in ETAG 001, Annex C or for equation (14) in CEN/TS 1992-4-4

TOX Drop-in Anchor E / ES

Performance

Characteristic resistance for $h_{ef} = 25$ mm in precast pre-stressed hollow core slabs

Annex C3

Table C4: Characteristic values under **fire exposure** in **solid concrete slabs** C20/25 to C50/60 for $h_{ef} \geq 30$ mm

Anchor size				M6x30	M8x30	M8x40	M10x30	M10x40	M12x50	M16x65	
Fire resistance class		Load in any direction									
Steel 4.6	R 30	Characteristic resistance	$F_{Rk,fi}^0$	[kN]	0,4	0,6	0,6	0,9	0,9	1,5	3,1
	R 60		[kN]	0,35	0,6	0,6	0,8	0,8	1,3	2,4	
	R 90		[kN]	0,30	0,6	0,6	0,6	0,6	1,1	2,0	
	R 120		[kN]	0,25	0,5	0,5	0,5	0,5	0,8	1,6	
Steel 4.8	R 30	Characteristic resistance	$F_{Rk,fi}^0$	[kN]	0,4	0,9	1,1	0,9	1,5	1,5	4,0
	R 60		[kN]	0,35	0,9	0,9	0,9	1,5	1,5	4,0	
	R 90		[kN]	0,3	0,6	0,6	0,9	1,1	1,5	3,0	
	R 120		[kN]	0,3	0,5	0,5	0,7	0,9	1,2	2,4	
Steel ≥ 5.6	R 30	Characteristic resistance	$F_{Rk,fi}^0$	[kN]	0,8	0,9	1,5	0,9	1,5	1,5	4,0
	R 60		[kN]	0,8	0,9	1,5	0,9	1,5	1,5	4,0	
	R 90		[kN]	0,4	0,9	0,9	0,9	1,5	1,5	3,7	
	R 120		[kN]	0,3	0,5	0,5	0,7	1,0	1,2	2,4	
A4 / HCR	R 30	Characteristic resistance	$F_{Rk,fi}^0$	[kN]	0,8	0,9	1,5	-	1,5	1,5	4,0
	R 60		[kN]	0,8	0,9	1,5	-	1,5	1,5	4,0	
	R 90		[kN]	0,4	0,9	0,9	-	1,5	1,5	3,7	
	R 120		[kN]	0,3	0,5	0,5	-	1,0	1,2	2,4	
Partial safety factor $\gamma_{M,fi}$			[-]	1,0							
Steel zinc plated											
R 30 – R 120	Spacing	$s_{cr,fi}$	[mm]	130	180	210	170	170	200	400	
	Edge distance	$c_{cr,fi}$	[mm]	65	90	105	85	85	100	200	
	If the fire attack is from more than one side, the edge distance shall be ≥ 300 mm.										
Stainless steel A4, HCR											
R 30 – R 120	Spacing	$s_{cr,fi}$	[mm]	130	180	210	-	170	200	400	
	Edge distance	$c_{cr,fi}$	[mm]	65	90	105	-	85	100	200	
	If the fire attack is from more than one side, the edge distance shall be ≥ 300 mm.										

TOX Drop-in Anchor E / ES

Performance
Characteristic values under **fire exposure** for $h_{ef} \geq 30$ mm

Annex C4

Table C5: Characteristic values under **fire exposure** in **solid concrete slabs** C20/25 to C50/60 for **$h_{ef} = 25$ mm**

Anchor size				M6x25	M8x25	M10x25	M12x25
Fire resistance class		Load in any direction					
Steel ≥ 4.6	R 30	Characteristic resistance $F^0_{Rk,fi}$	[kN]	0,4	0,6	0,6	0,6
	R 60		[kN]	0,35	0,6	0,6	0,6
	R 90		[kN]	0,30	0,6	0,6	0,6
	R 120		[kN]	0,25	0,5	0,5	0,5
Partial safety factor $\gamma_{M,fi}$			[-]	1,0			
R 30 – R 120	Spacing	$s_{cr,fi}$	[mm]	100	100	100	100
	Edge distance	$c_{cr,fi}$	[mm]	50	50	50	50
	If the fire attack is from more than one side, the edge distance shall be ≥ 300 mm.						

TOX Drop-in Anchor E / ES

Performance
Characteristic values under **fire exposure** for **$h_{ef} = 25$ mm**

Annex C5