

Approval body for construction products  
and types of construction

Bautechnisches Prüfamt

An institution established by the Federal and  
Laender Governments



## European Technical Assessment

ETA-11/0090  
of 7 June 2018

English translation prepared by DIBt - Original version in German language

### General Part

Technical Assessment Body issuing the  
European Technical Assessment:

Deutsches Institut für Bautechnik

Trade name of the construction product

Meckel & Weyel GF - stone stair

Product family  
to which the construction product belongs

Load-bearing bolt stair with steps made of natural stone or  
artificial stone for use as an indoor stair in buildings

Manufacturer

SE-GRANIT s.r.l.  
Via Pernisa n. 4  
37020 Lugo di Grezzana (VR)  
ITALIEN

Manufacturing plant

Plant 1 to 3

This European Technical Assessment  
contains

15 pages including 3 annexes which form an integral part  
of this assessment

This European Technical Assessment is  
issued in accordance with Regulation (EU)  
No 305/2011, on the basis of

EAD 340006-00-0506

The European Technical Assessment is issued by the Technical Assessment Body in its official language. Translations of this European Technical Assessment in other languages shall fully correspond to the original issued document and shall be identified as such.

Communication of this European Technical Assessment, including transmission by electronic means, shall be in full. However, partial reproduction may only be made with the written consent of the issuing Technical Assessment Body. Any partial reproduction shall be identified as such.

This European Technical Assessment may be withdrawn by the issuing Technical Assessment Body, in particular pursuant to information by the Commission in accordance with Article 25(3) of Regulation (EU) No 305/2011.

## Specific Part

### 1 Technical description of the product

The load-bearing bolt stair Meckel & Weyel GF stone stair is a prefabricated stair system which consists of steps made of natural stone or artificial stone (cement bonded or reaction resin bonded), load-bearing bolts and wall ties.

The steps consist of two plates that are glued together by an intermediate GFK-layer.

On the wall side and on the wall-free side the steps of the WF2-stair are connected with each other by one load-bearing bolt per side. On the wall side each step is equipped with one wall tie, which is anchored in the staircase wall. In the area of openings in the wall alternatively a construction with fixed load-bearing bolts and strengthened wall ties at the beginning and at the end or a steel beam (wall-replacement-beam according to Annex A3) can be used.

The steps of the WE1-stair are connected with each other by a load-bearing bolt on the wall-free side. On the wall side the steps are embedded in the wall.

The product description is given in Annex A. The material values, dimensions and tolerances of the components of the stair not indicated in the annexes shall correspond to the values laid down in the technical documentation<sup>1</sup>.

### 2 Specification of the intended use in accordance with the applicable European Assessment Document

The performances given in Section 3 are only valid if the stair is used in compliance with the specifications and conditions given in Annex B.

The verification and assessment methods on which this European Technical Assessment is based lead to the assumption of a working life of the stair of at least 50 years. The indications given on the working life cannot be interpreted as a guarantee given by the producer, but are to be regarded only as a means for choosing the right products in relation to the expected economically reasonable working life of the works.

<sup>1</sup> The technical documentation comprises all information of the holder of this ETA necessary for the production, installation and maintenance of the stair; these are in particular the structural analysis, design drawings and the manufacturer's installation instructions. The part to be treated confidentially is deposited with Deutsches Institut für Bautechnik and, as far as this is relevant to the tasks of the approved bodies involved in the procedure of the AVCP system, shall be handed over to the approved body.

### 3 Performance of the product and references to the methods used for its assessment

#### 3.1 Mechanical resistance and stability (BWR 1)

Essential characteristic	Performance
Load-bearing capacity of stair	See Annex C3
Load-bearing capacity of fixings	See technical documentation of this European Technical Assessment
Load/displacement behaviour	See Annex C3
Vibration behaviour	First natural frequency: $f_1 \geq 5$ Hz (inclusive a single mass of 100 kg) Deflection under a single load $F = 1$ kN: $w \leq 5$ mm
Prevention of progressive collapse	Failure of individual components of the stair does not lead to a progressive collapse of the complete stair
Residual load-bearing capacity	Local material failure does not lead to an abrupt total loss of load-bearing capacity of the steps.
Long-term behaviour	Load-bearing capacity are ensured under an appropriate use and maintenance over the indicated working life
Resistance to earthquakes	No performance assessed
Durability against physical, chemical and biological agents	Adequate durability for the intended use under an appropriate use and maintenance

#### 3.2 Safety in case of fire (BWR 2)

Essential characteristic	Performance
Reaction to fire	See Annex A5
Fire resistance	No performance assessed

#### 3.3 Hygiene, health and the environment (BWR 3)

Essential characteristic	Performance
Release of formaldehyde	Not relevant
Release of pentachlorophenol	Not relevant
Radioactive emission	No performance assessed

### 3.4 Safety in use (BWR 4)

Essential characteristic	Performance
Geometry	See Annex C1
Slipperiness	No performance assessed
Equipment of the stair for a safe use	No performance assessed
Safe breakage of components	No brittle failure of individual components
Impact resistance	Verified for steps made of natural stone or artificial stone up to a fall height of a steel weight (50 kg) of 200 mm

### 4 Assessment and verification of constancy of performance (AVCP) system applied, with reference to its legal base

In accordance with the European Assessment Document EAD No. 340006-00-0506 the applicable European legal act is: 1999/89/EC

The System to be applied is: 2+

In addition, with regard to reaction to fire for products covered by the European Assessment Document EAD No. 340006-00-0506 the applicable European legal act is: 2001/596/EC

The System to be applied is: 4

### 5 Technical details necessary for the implementation of the AVCP system, as provided for in the applicable European Assessment Document

Technical details necessary for the implementation of the AVCP system are laid down in the control plan deposited at Deutsches Institut für Bautechnik.

Issued in Berlin on 7 June 2018 by Deutsches Institut für Bautechnik

Dr.-Ing. Lars Eckfeldt  
p. p. Head of Department

*beglaubigt:*  
Stiller

### Types of plan

**Type 16G**

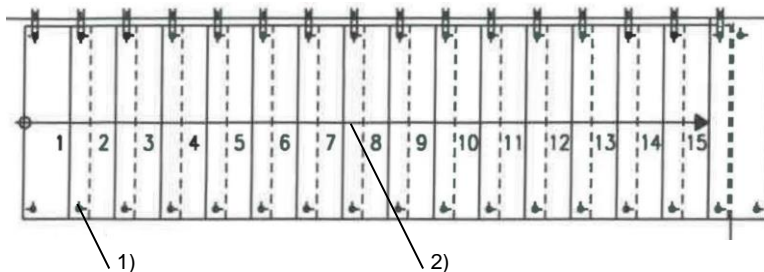

In the area of openings  
wall-replacement-beams are  
possible (see Annex A3).

- 1) additional support  
(according to Annex C2)
- 2) walking line is exemplified, position  
may be chosen freely within the  
walking zone, walking zone is 20 %  
of the clear width of the stair in the  
middle of the stair

**Type 16V**

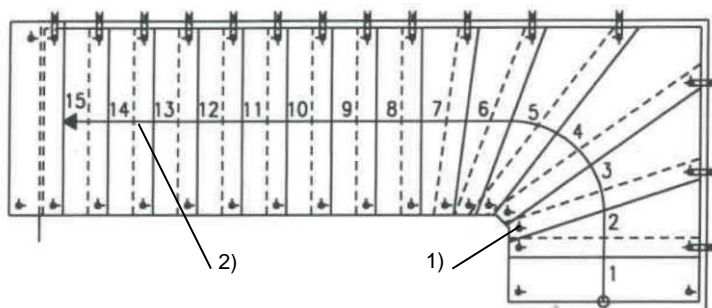

**Type 16VV**

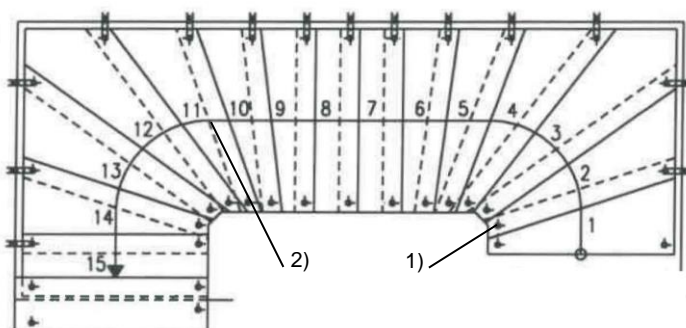

**Type 16H**

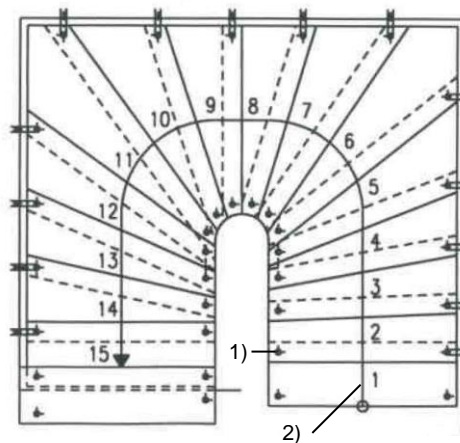

### Types of construction

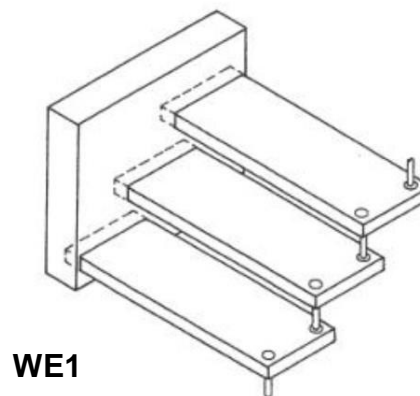
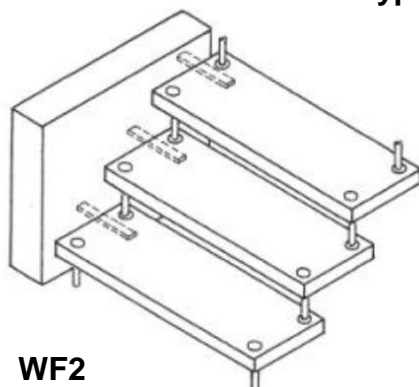

**Meckel & Weyel GF - stone stair**

Product

**Annex A1**

**Load-bearing bolt joint Type I**

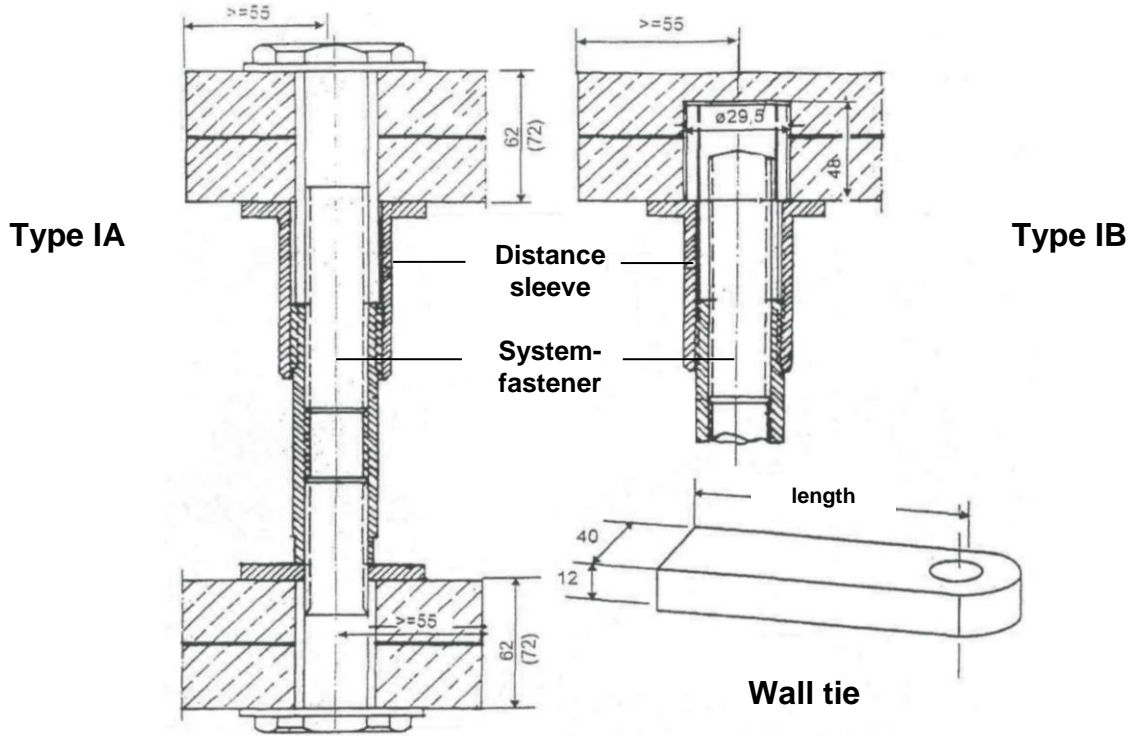

**Load-bearing bolt joint Type II**

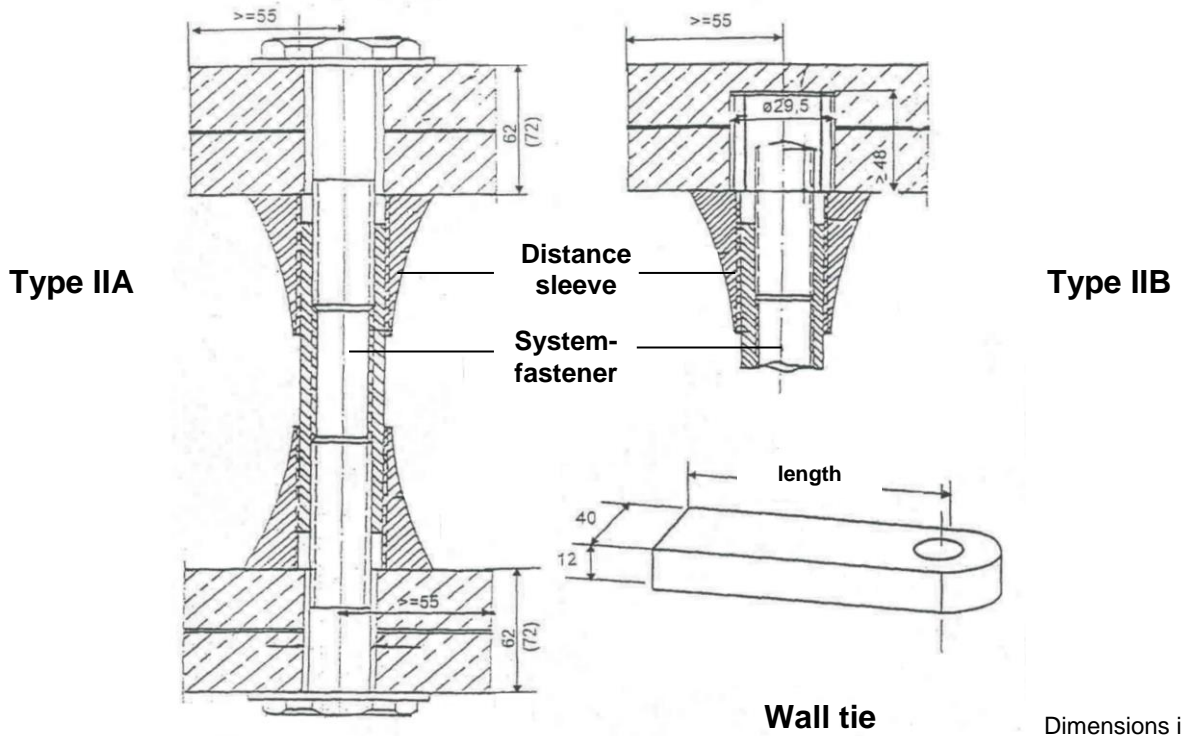

Dimensions in mm

**Meckel & Weyel GF - stone stair**

Load-bearing bolt joint and wall tie (standard joint)

**Annex A2**

### Wall-replacement-beam

#### a) Load-bearing bolt Type III or IV with strengthened wall ties

4 goings in the area of straight steps

3 goings in the area of tapered steps

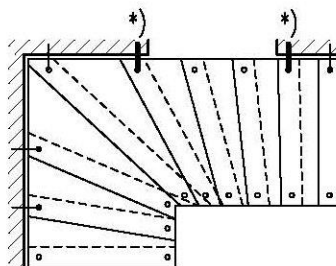
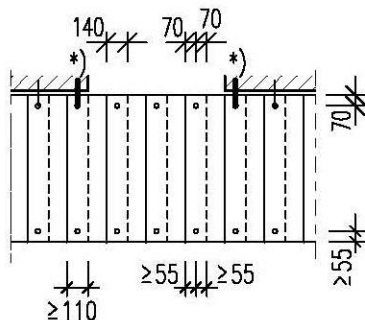

Load-bearing bolt joint Type III

Load-bearing bolt joint Type IV

\*) Wall tie (alternatively in-situ concrete  $\geq$  C16/20)

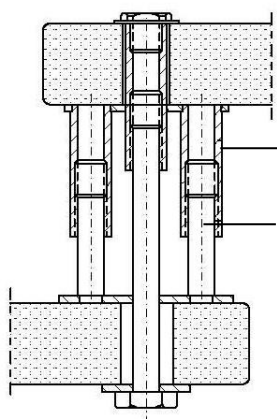

Distance sleeve  
System-fastener

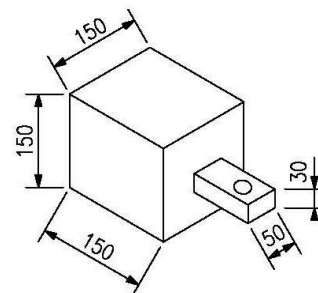
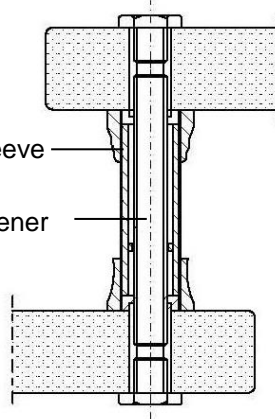

#### b) Cascaded steel beam (hollow section 60/60/5)

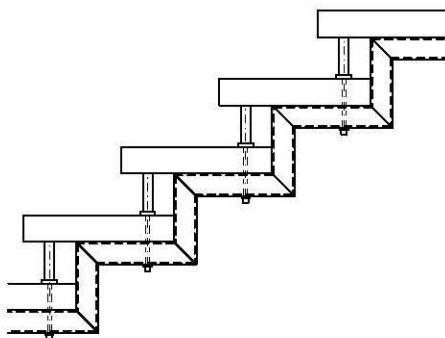

Dimensions in mm

Further details according to technical documentation

**Meckel & Weyel GF - stone stair**

Wall-replacement-beam

**Annex A3**



**Table 1: Characteristic values of materials of relevant stair components <sup>2)</sup>**

component of stair		material	characteristic values (minimum values)				
components made of natural stone			$E_{0,mean}$	$G_{mean}$	$f_{m,k}$	$f_{v,k}$	$\gamma_M^{1)}$
			[N/mm <sup>2</sup> ]	[N/mm <sup>2</sup> ]	[N/mm <sup>2</sup> ]	[N/mm <sup>2</sup> ]	[-]
steps	resistance class I	30000	10000	6.90	6.25	1.8	
	resistance class II			7.50	7.50		
	resistance class III			8.75	8.75		
	resistance class IV			10.00	10.00		
	resistance class V			11.25	11.25		
	resistance class VI			12.50	12.50		
components made of reaction resin bonded artificial stones			$E_{0,mean}$	$G_{mean}$	$f_{m,k}$	$f_{v,k}$	$\gamma_M^{1)}$
			[N/mm <sup>2</sup> ]	[N/mm <sup>2</sup> ]	[N/mm <sup>2</sup> ]	[N/mm <sup>2</sup> ]	[-]
steps	resistance class I	30000	10000	6.25	6.25	1.6	
	resistance class II			7.50	7.50		
	resistance class III			8.75	8.75		
	resistance class IV			10.00	10.00		
	resistance class V			11.25	11.25		
	resistance class VI			12.50	12.50		
components made of cement bonded artificial stones			$E_{0,mean}$	$G_{mean}$	$f_{m,k}$	$f_{v,k}$	$\gamma_M^{1)}$
			[N/mm <sup>2</sup> ]	[N/mm <sup>2</sup> ]	[N/mm <sup>2</sup> ]	[N/mm <sup>2</sup> ]	[-]
steps	resistance class I	30000	10000	8.0	8.0	1.6	
components made of steel			$E_{0,mean}$	$G_{mean}$	$f_{y,k}$	$f_{u,k}$	$\gamma_M^{1)}$
			[N/mm <sup>2</sup> ]	[N/mm <sup>2</sup> ]	[N/mm <sup>2</sup> ]	[N/mm <sup>2</sup> ]	[-]
system-fastener	steel	210000	81000	240	400	1.1	
distance sleeve	GD-Al Si 8 Cu 3	70000	27000	160	240		
wall tie	steel	210000	81000	360	600		
cascaded beam	steel	210000	81000	240	360		

1) recommended partial safety factor, in absence of other national regulations

2) For each laminate process but at least each 100 m<sup>2</sup> the torsion resistance of at least one step have to be tested. On the basis of the ultimate torsion resistance reached the material is to be classified to the resistance classes. The ultimate torsion resistance shall not be less than values  $f_{v,k}$  of the appropriate resistance class. More details see control plan.

**Meckel & Weyel GF - stone stair**

Characteristic values of materials of relevant stair components

**Annex A4**

**Table 2: Minimum dimensions of relevant stair components and reaction to fire**

component	material	dimension	value	reaction to fire <sup>1)</sup>
steps	natural stone	thickness	[mm] 62 <sup>1)</sup>	A1
	artificial stone cement bonded	thickness	[mm] 62 <sup>1)</sup>	
	artificial stone reaction resin bonded	thickness	[mm] 62 <sup>1)</sup>	No performance assessed
system-fastener	steel	diameter	[mm] 14	A1
distance sleeve	GD-Al Si 8 Cu 3	inner diameter	[mm] 14	A1
wall tie	flat steel	height / width / length	[mm] 12 / 40 / 210	A1
		embedment depth - wall	[mm] 100	

<sup>1)</sup> two plates (minimum thickness 30 mm) and intermediate GFK-layer (thickness 2 mm)

**Meckel & Weyel GF - stone stair**

Minimum dimensions of relevant stair components  
and reaction to fire

**Annex A5**

## Specification of intended use (Part 1)

### Intended use:

- European Technical Assessment applies for a construction system.
- For the specific case of use the corresponding type of stair is manufactured within the context of the values defined in this European Technical Assessment.
- Values of this ETA apply to all types of stairs, the real dimensions follow in accordance with the relevant case of use.

### Stair subject to:

- Static and quasi static loads

### Use conditions:

- Indoor stair
- Air temperatures between +5 °C and +30 °C
- Relative air humidity between 30% and 70%
- To the individual requirements handrail and barrier can be attached to the stair optionally. Conditions for possible handrail/barrier:
  - Dead load  $\leq 0.15$  kN/m
  - Height  $\leq 1.00$  m
  - Distance of baluster  $\leq 0.85$  m

### Design:

- Design of the stair according to the annexes and the technical documentation of this European Technical Assessment.
- Depending on the relevant type of plan the declared resistance class of the steps shall not be less than the required resistance class according to Annex C2.
- Fastening of the stair to the construction works according to the annexes and the technical documentation of this Technical European Assessment.
- Verification of the transmission of loads to the construction works by the civil engineer responsible for the construction works.
- Load bearing capacity at ultimate limit state:

$$q_k \cdot \gamma_Q \leq q_{RK} / \gamma_M$$

$$Q_k \cdot \gamma_Q \leq Q_{RK} / \gamma_M$$

$$h_k \cdot \gamma_Q \cdot \psi_0 \leq h_{RK} / \gamma_M$$

with

- $q_{RK}, Q_{RK}, h_{RK}$ : characteristic values of resistance; see Table 5
- $\gamma_M$ : recommended material partial safety factor; see Table 5
- $q_k, Q_k, h_k$ : characteristic values of imposed loads according to EN 1991-1-1:2002 + AC:2009
- $\gamma_Q = 1.5$ : recommended partial safety factor, in absence of other national regulations
- $\psi_0 = 0.7$ : recommended combination factor, in absence of other national regulations

- Maximum characteristic values of imposed loads under consideration of the partial factors mentioned above; see Table 7

**Meckel & Weyel GF - stone stair**

Specification of intended use (Part 1)

**Annex B1**

## Specification of intended use (Part 2)

### Installation:

- Installation by personal appropriately trained and authorized by the manufacturer by means of the technical documentation of this European Technical Assessment
- Installation only in the way as specified in the technical documentation of this European Technical Assessment
- Sufficient support of the stair when assembling
- Installation of stair components without imposed deformations
- Installation of stair components without significant defects and cracks
- Replacing of stair components, which begin tearing when assembling
- Bolted connection are protected such that they will not be loosened by vibrations

### Indication of the manufacturer:

- Ensure that all persons involved will be appropriately informed about the specific conditions according to sections 1 and 2 (including the annexes to which reference is being made as well as the not confidential parts of the technical documentation deposited to this European Technical Assessment)
- Instructions for use should provide information as to use, maintenance and repair of the stair

**Meckel & Weyel GF - stone stair**

Specification of intended use (Part 2)

**Annex B2**

**Table 3: Geometry**

designation			dimension	
			minimum	maximum
going	step on walking line <sup>1)</sup>	[mm]	210	290 <sup>2)</sup>
	tapered step	[mm]	100 <sup>2) 3)</sup>	550 <sup>2) 4)</sup>
rise of the stairs <sup>1)</sup>		[mm]	140 <sup>2)</sup>	210
pitch of the walking line <sup>1)</sup>		[°]	21	45
overlap of the steps		[mm]	110	- <sup>5)</sup>
number of rises		[-]	3	16
openings	between stairs and wall	[mm]	- <sup>5)</sup>	55
	between consecutive steps	[mm]	- <sup>5)</sup>	148
clear width of stairs		[mm]	500	1050
minimum headroom		[mm]	- <sup>5)</sup>	
length of the flight		[mm]	- <sup>5)</sup>	3900
thickness of steps		[mm]	62	- <sup>5)</sup>

- 1) values are constant within one flight
- 2) tolerance between nominal value and actual value = ± 5 mm
- 3) inside of tapered step
- 4) outside of tapered step
- 5) not relevant

- 1 going
- 2 rise
- 3 overlap
- 4 opening between consecutive steps
- 5 length of the flight
- 6 thickness of steps

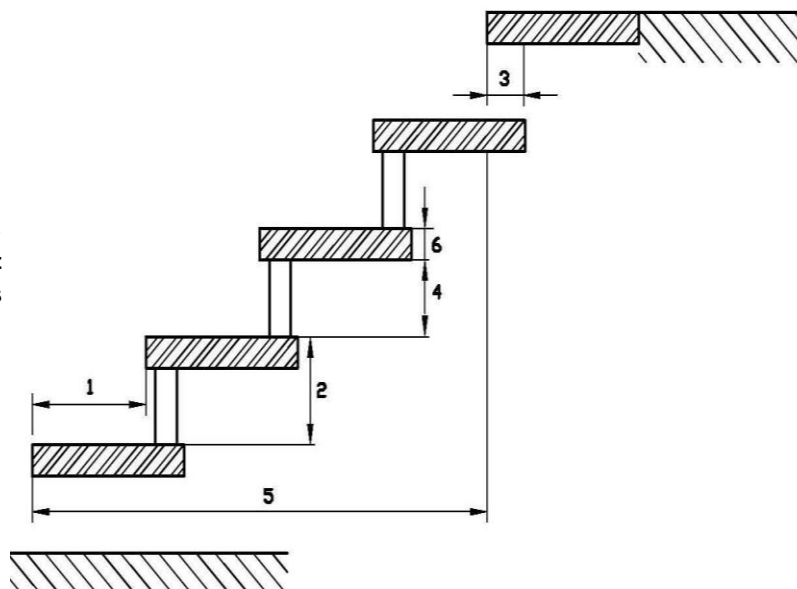

**Meckel & Weyel GF - stone stair**

Geometry of the stair

**Annex C1**

**Table 4: Required resistance classes according to Annex A4, Table 1 for types of plan according to Annex A1**

type of plan	support at step	number of steps <sup>2)</sup>	thickness of steps 62 mm		thickness of steps 72 mm	
			artificial stone <sup>4)</sup>	natural stone	artificial stone <sup>4)</sup>	natural stone
16G	-	15	IV	V	III	IV
	2	14	IV	V	II	III
	3	13	III	IV	II	III
	4	12	III	III	I	II
	5	11	II	III	I	I
	6	10	I	II	I	I
	7	9	I	I	I	I
16V	-	15	IV	V	III	III
	2	14	III	IV	II	III
	3	13	II	III	I	II
	4	12	II	II	I	I
	5	11	I	II <sup>3)</sup>	I	I
16VV	-	15	IV	IV	II	III
	2	14	II	II (III) <sup>1)</sup>	I (II) <sup>1)</sup>	I (II) <sup>1)</sup>
	3	13	II	II (III) <sup>1)</sup>	I	II
	4	12	I	II	I	I
	5	11	I	II <sup>3)</sup>	I	I
16H	-	15	IV	V	III	III
	2	14	IV	V	III	III
	3	13	IV	V	III	III
	4	12	III	IV	II	III
	5	11	III	III	I	II
	6	10	III	III	I	II
	7	9	II	III	I	II
Wall-replacement-beam			III		II	

- 1) values in brackets valid for plans with straight bottom step or straight top step  
 2) number of steps without additional support  
 3) resistance class I sufficiently if the length of the steps ≤ 940 mm  
 4) cement bonded artificial stone is only in resistance class I possible

**Meckel & Weyel GF - stone stair**

Required resistance classes

**Annex C2**

**Table 5: Load-bearing capacity - Characteristic values of resistance**

Material	Component	Type of loading	Characteristic values of resistance			$\gamma_M$ <sup>1)</sup>
naturel stone	flight	vertical variable uniformly distributed load	$q_{RK}$	[kN/m <sup>2</sup> ]	8.10	1.8
	step	vertical variable single load	$Q_{RK}$	[kN]	5.40	
	barrier	horizontal variable uniformly distributed load on barrier	$h_{RK}$	[kN/m]	0.95	
artificial stone	flight	vertical variable uniformly distributed load	$q_{RK}$	[kN/m <sup>2</sup> ]	7.20	1.6
	step	vertical variable single load	$Q_{RK}$	[kN]	4.80	
	barrier	horizontal variable uniformly distributed load on barrier	$h_{RK}$	[kN/m]	0.84	

<sup>1)</sup> Recommended partial safety factor, in absence of other national regulations

**Table 6: Deflections under loading**

Deflection of the flight under uniformly distributed load			
uniformly distributed load	$q_k$	[kN/m <sup>2</sup> ]	3.0
length of the median line of the flight	L	[mm]	3900
deflection under load $F_S$ related to the median line of the flight	w	[-]	$\leq L/200$
Deflection of the step under single point load			
single load	$Q_k$	[kN]	2.0
clear width of the stair	L	[mm]	1050
deflection under load $F_S$ related to the clear width of the stair	w	[-]	$\leq L/200$

**Table 7: Imposed loads**

Type of loading	Imposed loads		
vertical variable uniformly distributed load	q	[kN/m <sup>2</sup> ]	3.0
vertical variable single load	Q	[kN]	2.0
horizontal variable uniformly distributed load on barrier	h	[kN/m]	0.5

**Meckel & Weyel GF - stone stair**

Load-bearing capacity - Characteristic values of resistance,  
Deflections under loading  
Imposed loads

**Annex C3**