

Approval body for construction products  
and types of construction

Bautechnisches Prüfamt

An institution established by the Federal and  
Laender Governments



## European Technical Assessment

ETA-11/0436  
of 26 July 2018

English translation prepared by DIBt - Original version in German language

### General Part

Technical Assessment Body issuing the  
European Technical Assessment:

Deutsches Institut für Bautechnik

Trade name of the construction product

RELIUS V510, V510D, V510M

Product family  
to which the construction product belongs

Product area code: 4  
External Thermal Insulation Composite System with  
rendering on expanded polystyrene intended for use on  
building walls

Manufacturer

RELIUS Farbenwerke GmbH  
Heimertinger Straße 10  
87700 Memmingen  
DEUTSCHLAND

Manufacturing plant

RELIUS Farbenwerke GmbH  
Heimertinger Straße 10  
87700 Memmingen  
DEUTSCHLAND

This European Technical Assessment  
contains

15 pages including 4 annexes which form an integral part  
of this assessment

Annex 5 Control Plan contains confidential information  
and is not included in the European Technical  
Assessment when that assessment is publicly available

This European Technical Assessment is  
issued in accordance with Regulation (EU)  
No 305/2011, on the basis of

ETAG 004, edition 2000, amended 2013,  
used as EAD according to Article 66 Paragraph 3 of  
Regulation (EU) No 305/2011.

This version replaces

ETA-11/0436 issued on 20 April 2016

**European Technical Assessment**

**ETA-11/0436**

English translation prepared by DIBt

Page 2 of 15 | 26 July 2018

The European Technical Assessment is issued by the Technical Assessment Body in its official language. Translations of this European Technical Assessment in other languages shall fully correspond to the original issued document and shall be identified as such.

Communication of this European Technical Assessment, including transmission by electronic means, shall be in full. However, partial reproduction may only be made with the written consent of the issuing Technical Assessment Body. Any partial reproduction shall be identified as such.

This European Technical Assessment may be withdrawn by the issuing Technical Assessment Body, in particular pursuant to information by the Commission in accordance with Article 25(3) of Regulation (EU) No 305/2011.

## Specific Part

### 1 Technical description of the product

#### 1.1 Definition of the kit

This product is an External Thermal Insulation Composite System (ETICS) with rendering - a kit comprising components which are factory-produced by the manufacturer or component suppliers. It's made up on site from these. The ETICS manufacturer is ultimately responsible for all components of the ETICS specified in this ETA.

The ETICS kit comprises a prefabricated insulation product of expanded polystyrene (EPS) to be bonded and if it necessary additionally mechanically fixed onto a wall. The methods of fixing and the relevant components are specified in the table below.

The insulation product is faced with a rendering system consisting of one base coat and finishing coat (site applied), in which the base coat contains reinforcement. The rendering is applied directly to the insulating panels, without any air gap or disconnecting layer.

The ETICS may include special fittings (e.g. base profiles, corner profiles ...) for connection to adjacent building elements (apertures, corners, parapets ...). Assessment and performance of these components is not addressed in this ETA, however the ETICS manufacturer is responsible for adequate compatibility and performance within the ETICS when the components are delivered as a part of the kit.

#### 1.2 Composition of the ETICS

	Components	Coverage [kg/m <sup>2</sup> ]	Thickness [mm]
	National application documents shall be taken into account		
Insulation material with associated method of fixing	<b>Bonded ETICS:</b> <ul style="list-style-type: none"> <li>• <b>Insulation product</b> (see annex 1 for product characteristics) factory-prefabricated expanded polystyrene (EPS) <ul style="list-style-type: none"> <li>– standard EPS</li> </ul> </li> <li>• <b>Adhesives</b> (minimum bonded surface 40%) <ul style="list-style-type: none"> <li>– <b>RELIUS PHS</b> (cement based powder requiring addition of about 25 % of water)</li> <li>– <b>RELIUS K.A.m</b> (cement based powder requiring addition of about 25 % of water)</li> <li>– <b>RELIUS V600 ZF</b> (organic based ready to use paste – binder polymerdispersion)</li> </ul> </li> </ul>	–  } about 4.0 (powder)  about 3.2 (prepared)	≤ 360  –  –
	<b>Mechanically fixed ETICS with profiles and supplementary adhesive:</b> <ul style="list-style-type: none"> <li>• <b>Insulation product</b> (see annex 1 for product characteristics) factory-prefabricated expanded polystyrene (EPS) <ul style="list-style-type: none"> <li>- standard EPS</li> </ul> </li> <li>• <b>Supplementary adhesive</b> (equal to bonded ETICS, minimum bonded surface 40 %)</li> </ul>	–	60 to 200

	<b>Components</b> National application documents shall be taken into account	<b>Coverage</b> [kg/m <sup>2</sup> ]	<b>Thickness</b> [mm]
<b>Insulation material with associated method of fixing</b>	<ul style="list-style-type: none"> <li>• <b>Profiles</b> (see annex 3 for product characteristics) <ul style="list-style-type: none"> <li>– "RELIUS Halteleiste PVC"</li> <li>– "RELIUS Verbindungsschiene PVC"</li> </ul> </li> <li>Polyvinyl chloride (PVC) – profiles</li> <li>• <b>Anchors for profiles</b> (see annex 2 for product characteristics) <ul style="list-style-type: none"> <li>– WS 8 L</li> <li>– WS 8 N</li> <li>– ejothem SDK U</li> <li>– SDF-K plus</li> <li>– ejothem NK U</li> </ul> </li> </ul>		
	<p><b>Mechanically fixed ETICS with anchors and supplementary adhesive:</b></p> <ul style="list-style-type: none"> <li>• <b>Insulation product</b> (see annex 1 for product characteristics) factory-prefabricated expanded polystyrene (EPS) - standard EPS</li> <li>• <b>Supplementary adhesives</b> (equal to bonded ETICS, minimum bonded surface 40 %)</li> <li>• <b>Anchors for insulation product</b> (see annex 1 for product characteristics) all anchors with ETA according to EAD330196-01-0604<sup>1</sup></li> </ul>	–  4.0 to 6.0	60 to 360  –
<b>Base coat</b>	<b>RELIUS V600 ZF</b> identical with the equally named adhesives given above	4.2 to 7.2 (prepared)	3.0 to 6.0
<b>Glass fibre mesh</b>	<b>RELIUS Gittergewebe</b> Alkali- and slide-resistant glass fibre mesh with mass per unit area of about 165 g/m <sup>2</sup> and mesh size of about 4.0 mm x 4.0 mm. (see annex 4 for product characteristics)	–	–
<b>Finishing coat</b>	<ul style="list-style-type: none"> <li>• Ready to use paste – binder polymerdispersion: <b>RELIUS Edelputz K *</b> (particles size 1 – 1.5 – 2 and 3 mm) <b>RELIUS Rillenputz R *</b> (particles size 1.5 – 2 and 3 mm)</li> <li>• Ready to use paste - acrylosiloxane binder: <b>RELIUS Silcosan Edelputz K *</b> (particles size 1 – 1.5 – 2 and 3 mm) <b>RELIUS Silcosan Rillenputz R *</b> (particles size 1.5 – 2 and 3 mm)</li> </ul>	2.0 to 4.0  2.0 to 4.0	} Regulated by particles size
<b>Ancillary material</b>	Remains the responsibility of the manufacturer.		

\* K / R indicates different structures of the finishing coats.

<sup>1</sup> EAD330196-01-0604 Plastic anchors for fixing of external thermal insulation composite systems with rendering

## 2. Specification of the intended use in accordance with the applicable European assessment Document (hereinafter called EAD)

### 2.1 Intended use

This ETICS is intended to be used as external insulation to the walls of buildings made of masonry (bricks, blocks, stones ...) or concrete (cast on site or as prefabricated panels) with and without rendering. The characteristics of the walls shall be verified prior to use of the ETICS, especially regarding conditions for reaction to fire classification and for fixing of the ETICS either by bonding or mechanically. It shall be designed to give the wall to which it is applied satisfactory thermal insulation.

The ETICS is non load-bearing construction element. It does not contribute directly to the stability of the wall on which it is installed, but it can contribute to durability by providing enhanced protection from the effects of weathering.

The ETICS can be used on new or existing (retrofit) vertical walls.

The ETICS is not intended to ensure the air tightness of the building structure.

The choice of the method of fixing depends on the characteristics of the substrate, which could need preparation (see clause 7.2.1 of ETAG 004) and on the national instructions.

The verifications and assessment methods on which this European Technical Assessment (hereinafter called ETA) is based lead to the assumption of a working life of the ETICS "RELIUS V510, V510D, V510M" of at least 25 years. The indications given on the working life cannot be interpreted as a guarantee given by the manufacturer, but are to be regarded only as a means for choosing the right products in relation to the assumed economically reasonable working life of the works.

### 2.2 Manufacturing

The ETA is issued for the ETICS on the basis of agreed data/information, deposited with the DIBt, which identifies the ETICS that has been assessed and judged. Changes to the ETICS or the components or their production process, which could result in this deposited data/information being incorrect, should be notified to the DIBt before the changes are introduced. The DIBt will decide whether such changes affect the approval and consequently the validity of the CE marking on the basis of the approval and if so whether further assessment or alterations to the approval shall be necessary.

### 2.3 Design and installation

The installation instructions including special installation techniques and provisions for the qualification of the personnel are given in the manufacturer's technical documentation.

Design, installation and execution of ETICS are to be in conformity with national documents. Such documents and the level of their implementation in Member States' legislation are different. Therefore, the assessment and declaration of performance are done taking into account general assumptions introduced in the chapters 7.1 and 7.2 of ETAG 004 used as EAD, which summarize how information introduced in the ETA and related documents is intended to be used in the construction process and gives advice to all parties interested when normative documents are missing.

### 2.4 Packing, transport and storage

The information on packaging, transport and storage is given in the manufacturer's technical documentation. It is the responsibility of the manufacturer to ensure that this information is made known to the concerned people.

English translation prepared by DIBt

## 2.5 Use, maintenance, repair

The finishing coat shall normally be maintained in order to fully preserve the ETICS performance. Maintenance includes at least:

- visual inspection of the ETICS
- the repairing of localized damaged areas due to accidents
- the aspect maintenance with products adapted and compatible with the ETICS (possibly after washing or ad hoc preparation)

Only products which are compatible with the ETICS shall be used.

Necessary repairs should be performed as soon as the need has been identified.

The information on use, maintenance and repair is given in the manufacturer's technical documentation.

It is the responsibility of the manufacturer to ensure that this information is made known to the concerned people.

## 3 Characteristics of products and methods of verification

### 3.0 General

The performances of the kit as described in this chapter are valid provided that the components of the kit comply with Annexes 1 to 4.

### 3.1 Mechanical resistance and stability (BWR 1)

not relevant

### 3.2 Safety in case of fire (BWR 2)

#### Reaction to fire (ETAG 004 - clause 5.1.2)

Configurations	Organic content	Flame retardant content	Euroclass according to EN 13501-1:2007
Base coat	max. 7.5 %	min. 20.0 %	B – s2.d0
EPS-insulation product	in quantity ensuring Euro-class E according to EN 13501-1	in quantity ensuring Euro-class E according to EN 13501-1	
profiles	-	-	
anchors	-	-	
<b>rendering system:</b> Base coat with finishing coat indicated hereafter:			
RELIUS Edelputz K RELIUS Rillenputz R	max. 6.5 %	min. 5.0 %	
RELIUS Silcosan Edelputz K RELIUS Silcosan Rillenputz R	max. 6.5%	min. 5.0 %	

### 3.3 Hygiene, health and environment (BWR 3)

#### 3.3.1 Water absorption (capillarity test) (ETAG 004 - clause 5.1.3.1)

##### Base coat:

- Water absorption after 1 hour < 1.0 kg/m<sup>2</sup>
- Water absorption after 24 hours < 0.5 kg/m<sup>2</sup>

English translation prepared by DIBt

**Rendering system:**

		Water absorption after 24 h	
		< 0.5 kg/m <sup>2</sup>	≥ 0.5 kg/m <sup>2</sup>
<b>Rendering system:</b> Base coat with finishing coat indicated hereafter	RELIUS Edelputz K and RELIUS Rillenputz R	x	
	RELIUS Silcosan Edelputz K and RELIUS Silcosan Rillenputz R	x	

**3.3.2 Hygrothermal behaviour (ETAG 004 – clause 5.1.3.2)**

Pass (without defects)

**3.3.3 Impact resistance (ETAG 004 – clause 5.1.3.3)**

<b>Rendering system:</b> Base coat with finishing coat indicated hereafter:	Single mesh: "RELIUS Gittergewebe"
RELIUS Edelputz K and RELIUS Rillenputz R	category II
RELIUS Silcosan Edelputz K and RELIUS Silcosan Rillenputz R	category II

**3.3.4 Water vapour permeability (ETAG 004 – clause 5.1.3.4)**

<b>Rendering system:</b> Base coat with finishing coat indicated hereafter:	Equivalent air thickness $s_d$
RELIUS Edelputz K and RELIUS Rillenputz R	≤ 1.0 m (Test result obtained with particle size 6 mm : 0.6 m)
RELIUS Silcosan Edelputz K and RELIUS Silcosan Rillenputz R	≤ 1.0 m (Test result obtained with particle size 6 mm : 0.6 m)

**3.3.5 Release of dangerous substances (ETAG 004 – clause 5.1.3.5, EOTA TR 034)**

Essential characteristic	Performance
Release of dangerous substances	no performance assessed

**3.4 Safety and accessibility in use (BWR 4)**

**3.4.1 Bond strength between base coat and insulation product (EPS) (ETAG 004 – clause 5.1.4.1.1)**

Conditioning		
Initial state	After hygrothermal cycles	After freeze/thaw test
≥ 0.08 MPa	≥ 0.08 MPa	Test not required because freeze/thaw cycles not necessary

**3.4.2 Bond strength between adhesives and substrate resp. insulation product (EPS) (ETAG 004 – clauses 5.1.4.1.2 and 5.1.4.1.3)**

Adhesive	Substrate resp. insulation product	Conditioning		
		Initial state	2 d immersion in water and 2 h drying	2 d immersion in water and 7 d drying
RELIUS PHS	Concrete	≥ 0.25 MPa	≥ 0.08 MPa	≥ 0.25 MPa
	EPS	≥ 0.08 MPa	≥ 0.03 MPa	≥ 0.08 MPa
RELIUS K.A.m	Concrete	≥ 0.25 MPa	≥ 0.08 MPa	≥ 0.25 MPa
	Aerated concrete	≥ 0.25 MPa	≥ 0.08 MPa	≥ 0.25 MPa
	EPS	≥ 0.08 MPa	≥ 0.03 MPa	≥ 0.08 MPa
RELIUS V600 ZF	Concrete	≥ 0.25 MPa	≥ 0.08 MPa	≥ 0.25 MPa
	Aerated concrete	≥ 0.25 MPa	≥ 0.08 MPa	≥ 0.25 MPa
	EPS	≥ 0.08 MPa	≥ 0.03 MPa	≥ 0.08 MPa

Bonded surface:

For bonded ETICS the calculated minimal bonded surface area, according to ETAG 004, clause 6.1.4.1.3 is 40 %.

**3.4.3 Bond strength after ageing (ETAG 004 – clause 5.1.7.1)**

<b>Rendering system:</b> Base coat with finishing coat indicated hereafter	RELIUS Edelputz K and RELIUS Rillenputz R	≥ 0.08 MPa
	RELIUS Silcosan Edelputz K and RELIUS Silcosan Rillenputz R	

**3.4.4 Fixing strength (displacement test) (ETAG 004 – clause 5.1.4.2)**

Test not required therefore no limitation of ETICS length required

**3.4.5 Wind load resistance (ETAG 004 – clause 5.1.4.3)**

The following failure loads only apply to the listed of component characteristics and the characteristics of the insulation product given in annex 1.

**3.4.5.1 Safety in use of mechanically fixed ETICS using profiles**

Characteristics of the EPS <b>(standard EPS)</b>	Dimensions	500 mm x 500 mm
	Thickness	≥ 60 mm
	<b>Tensile strength perpendicular to the faces</b>	<b>≥ 150 kPa</b>
	Shear modulus	≥ 1.0 N/mm <sup>2</sup>
Failure load [N / panel] (Static Foam Block Test)	Horizontal profiles fixed every 30 cm and 49.4 cm long vertical connection profiles	Minimal: 950 Average: 1010



3.4.5.2 Safety in use of mechanically fixed ETICS using anchors

Apply to all anchors listed in the clause 1.2 mounted on the insulation panels surface				
Characteristics of the EPS (standard EPS)	Thickness		≥ 60 mm	
	Tensile strength perpendicular to the faces		≥ 100 kPa	
	Shear modulus		≥ 1.0 N/mm <sup>2</sup>	
Plate diameter of anchor			Ø 60 mm	Ø 90 mm
Failure load [N]	Anchors not placed at the panel joints (Static Foam Block Test)	R <sub>panel</sub>	Minimal: 510 Average: 520	Minimal: 720 Average: 730
	Anchors placed at the panel joints (Pull-through test)	R <sub>joint</sub>	Minimal : 400 Average: 430	Minimal: 430 Average: 470

The failure loads specified above for a plate diameter of anchor of 60 mm apply to the following anchors with deep mounting but only on the following conditions of installation:

Anchor	Thickness of the EPS [d]	Conditions of installation*
ejothem STR U (ETA-04/0023)	100 mm > d ≥ 80 mm (for standard EPS)	– Maximum installation depth of the anchor plate: 15 mm (△ thickness of insulation cover) – Maximum depth of die: 5 mm
	≥ 100 mm (for standard EPS)	– Maximum installation depth of the anchor plate: 15 mm (△ thickness of insulation cover) – Maximum depth of die: 20 mm

\* according to the appropriate ETA of anchor

3.4.6 Render strip tensile test (ETAG 004 – clause 5.5.4.1)

No performance determined for the width of cracks.

3.5 Protection against noise (BWR 5)

For the protection against noise no performance was assessed for this product.

3.6 Energy economy and heat retention (BWR 6)

3.6.1 Thermal resistance

The nominal value of the additional thermal resistance R provided by the ETICS to the substrate wall is calculated in accordance with EN ISO 6946:2007 from the nominal value of the insulation product's thermal resistance R<sub>D</sub> given accompanied to the CE marking and from the thermal resistance of the rendering system R<sub>render</sub> which is about 0.02 (m<sup>2</sup> · K)/W.

$$R = R_D + R_{render}$$

The thermal bridges caused by anchors profiles increases the thermal transmittance U. This influence had to take into account according to EN ISO 6946:2007.

$$U_c = U + \chi_p \cdot n$$

Where: U<sub>c</sub>: corrected thermal transmittance [W/ (m<sup>2</sup> · K)]

n: number of anchors per m<sup>2</sup>

χ<sub>p</sub>: local influence of thermal bridge caused by an anchor. The values listed below can be taken into account if not specified in the anchor's ETA:

χ<sub>p</sub> = 0.004 W/K for anchors with a galvanized steel screw with the head covered by a plastic material

English translation prepared by DIBt

$\chi_p = 0.002$  W/K for anchors with a stainless steel screw covered by plastic anchors and for anchors with an air gap at the head of the screw

The thermal bridges caused by profiles are negligible.

**4 Assessment and verification of constancy of performance system applied (AVCP), with reference to its legal base**

According to the European Commission decision 97/556/EC amended by the European Commission decision 2001/596/EC, the Assessment and verification of constancy of performance system (AVCP) applies suitable following table(see Annex V to Regulation (EU) No 305/2011).

Product	Intended use	Levels or classes (Reaction to fire)	Systems
"RELIUS V510, V510D, V510M"	ETICS in external wall subject to fire regulations	A1 <sup>(1)</sup> , A2 <sup>(1)</sup> , B <sup>(1)</sup> , C <sup>(1)</sup>	1
		A1 <sup>(2)</sup> , A2 <sup>(2)</sup> , B <sup>(2)</sup> , C <sup>(2)</sup> , D, E, (A1 to E) <sup>(3)</sup> , F	2+
	ETICS in external wall not subject to fire regulations	any	2+
<sup>(1)</sup> Products/materials for which a clearly identifiable stage in the production process results in an improvement of the reaction to fire classification (e.g. an addition of fire retardants or a limiting of organic material) <sup>(2)</sup> Products/materials not covered by footnote (1) <sup>(3)</sup> Products/materials that do not require to be tested for reaction to fire (e.g. products/materials of Classes A1 according to Commission Decision 96/603/EC)			

**5 Technical details necessary for the implementation of the AVCP system, as provided for in the applicable European Assessment Document (EAD)**

Technical details necessary for the implementation of the AVCP system are laid down in the control plan deposited at Deutsches Institut für Bautechnik.

Issued in Berlin on 26 July 2018 by Deutsches Institut für Bautechnik

Dirk Brandenburger  
Head of Department

*beglaubigt:*  
Ruppert

**Annexes:**

Annex 1:	Thermal insulation product characteristic
Annex 2:	Anchors
Annex 3:	Profiles
Annex 4:	Reinforcement

**Annex 1: Thermal insulation product characteristic**

Factory-prefabricated, uncoated panels made of expanded polystyrene (EPS) to EN 13163:2015 shall be used, having the description and characteristics defined in the Table below.

Description and characteristics	For bonded ETICS	For mechanically fixed ETICS	
		with anchors and supplementary adhesive	with profiles and supplementary adhesive ***
Reaction to fire; EN 13501-1:2007	Class E*		
Thermal resistance [(m <sup>2</sup> .K)/W]	Defined in the CE marking in reference to EN 13163:2015		
<b>Tolerances</b>			
Length; EN 822:2013	± 0.6 % or ± 3 mm whichever gives the greatest numerical tolerance (class L3)		
Width [mm]; EN 822:2013	± 2 (class W2)		
Thickness [mm]; EN 823:2013	± 1 (class T1)		
Squareness [mm/m]; EN 824:2013	± 2 (class S2)		
Flatness [mm/m]; EN 825:2013	5 (class P5)		
<b>Dimensional stability under</b>			
- laboratory conditions [%]; EN 1603:2013	± 0.2 (class DS(N)2)		
- specified temperature and humidity conditions [%]; EN 1604:2013	2 (level DS(70,-)2 or level DS(70,-)1)		
Water absorption (long term partial immersion) [kg/m <sup>2</sup> ]; EN 12087:2013	W <sub>ip</sub> ≤ 0.5		
Water vapour diffusion resistance factor; EN 12086:2013	μ = 20 – 78		
Tensile strength perpendicular to the faces in dry conditions** [kPa]; EN 1607:2013 - standard EPS	σ <sub>mt</sub> ≥ 80	σ <sub>mt</sub> ≥ 100	σ <sub>mt</sub> ≥ 150
Bending strength** [kPa]; EN 12089:2013	σ <sub>b</sub> ≥ 50		
Apparent density [kg/m <sup>3</sup> ]; EN 1602:2013	ρ <sub>a</sub> ≤ 30		
Shear strength** [kPa]; EN 12090:2013	20 ≤ f <sub>tk</sub> ≤ 170		
Shear modulus [MPa]; EN 12090:2013 - standard EPS	1.0 ≤ G <sub>m</sub> ≤ 3.8		
Testing of characteristics see EN 13163:2015.			
* See the conditions of clause 3.2 for the EPS.			
** Minimal value of all single values			
*** Thermal insulation materials for mechanically fixed ETICS with profiles must circumferentially at the edges, 24 mm from the inner surface, get an approx. 3 mm wide and 13 to 18 mm deep groove cut-in at the factory.			

**Annex 2: Anchors**

All anchors with ETA according to EAD330196-01-0604<sup>1</sup> with characteristics having the description below shall be used in the mechanically fixed ETICS:

- plate diameter of anchor  $\geq 60$  mm resp.  $\geq 90$  mm
- plate stiffness  $\geq 0.3$  kN/mm
- load resistance of the anchor plate  $\geq 1.0$  kN

These characteristics and the characteristic tension resistance of the anchors shall be taken from the corresponding ETA.

The anchors listed in the Table in clause 1.2 with reference to the respective ETA shall be used in the mechanically fixed ETICS with profiles for fixing the horizontal profiles.

Trade name	ETA-number
WS 8 L	ETA-02/0019
WS 8 N	ETA-03/0019
ejothem SDK U	ETA-04/0023
SDF-K plus	ETA-04/0064
ejothem NK U	ETA-05/0009

### Annex 3: Profiles

Polyvinyl chloride (PVC) profiles, PVC-U, EGL, 082-05-T33 to EN ISO 1163-1:1999 are to be used in the mechanically fixed ETICS with profiles.

The Pull-through resistance of fixings from profiles is  $\geq 500$  N.

#### Horizontal profile – "RELIUS Halteleiste PVC" (dimensions in millimetres)

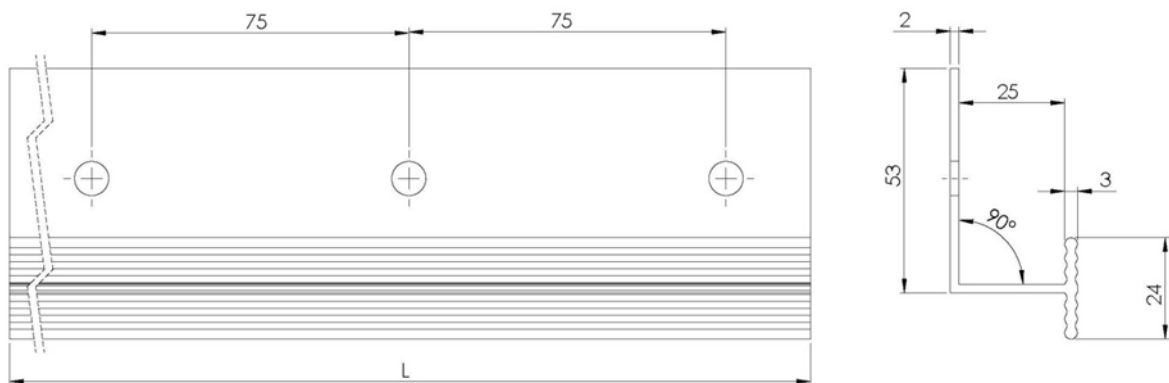

#### Vertical connection profile – "RELIUS Verbindungsschiene PVC" (dimensions in millimetres)

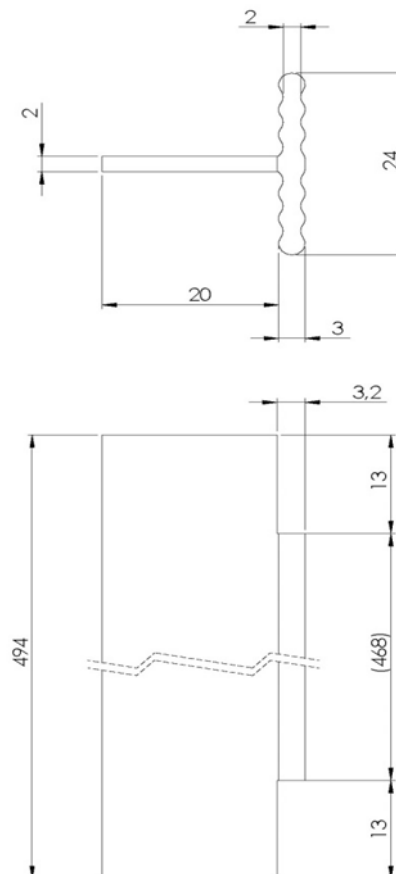

**Annex 4: Reinforcement (glass fibre mesh)**

Characteristics (alkali resistance): pass

	Description	Absolute strength after ageing [N/mm]	Relative residual strength after ageing, of the strength in the as-delivered state [%]
"RELIUS Gittergewebe"	Alkali- and slide-resistant glass fibre mesh with mass per unit area of about 165 g/m <sup>2</sup> and mesh size of about 4.0 mm x 4.0 mm	≥ 20	≥ 50