

Approval body for construction products
and types of construction

Bautechnisches Prüfamt

An institution established by the Federal and
Laender Governments



European Technical Assessment

ETA-12/0038
of 7 August 2018

English translation prepared by DIBt - Original version in German language

General Part

Technical Assessment Body issuing the
European Technical Assessment:

Deutsches Institut für Bautechnik

Trade name of the construction product

Screws Twin UD and PIR-FIX

Product family
to which the construction product belongs

Screws for use in timber constructions

Manufacturer

SFS intec AG
Division Construction
Rosenbergsaustraße 10
9435 HEERBRUGG
SCHWEIZ

Manufacturing plant

HECO-Schrauben GmbH & Co. KG
Dr. Kurt-Steim-Straße 28
78713 Schramberg

S.C. HECO Schrauben S.R.L.
Str. Laminoristilor Nr. 159
RO-405100 Campia Turzii

This European Technical Assessment
contains

22 pages including 4 annexes which form an integral part
of this assessment

This European Technical Assessment is
issued in accordance with Regulation (EU)
No 305/2011, on the basis of

EAD 130118-00-0603

This version replaces

ETA-12/0038 issued on 25 April 2017

The European Technical Assessment is issued by the Technical Assessment Body in its official language. Translations of this European Technical Assessment in other languages shall fully correspond to the original issued document and shall be identified as such.

Communication of this European Technical Assessment, including transmission by electronic means, shall be in full. However, partial reproduction may only be made with the written consent of the issuing Technical Assessment Body. Any partial reproduction shall be identified as such.

This European Technical Assessment may be withdrawn by the issuing Technical Assessment Body, in particular pursuant to information by the Commission in accordance with Article 25(3) of Regulation (EU) No 305/2011.

Specific Part

1 Technical description of the product

Twin UD and PIR-FIX screws are self-tapping screws made from special carbon steel. They have a corrosion protection according to Annex A.2.6. The outer thread diameter of the threaded part close to the head is 8.8 mm and 7.5 mm in the threaded part close to the tip. The overall length of the screws is ranging from 170 mm to 600 mm (nominal dimension). Further dimensions are shown in Annex 4.

2 Specification of the intended use in accordance with the applicable European Assessment Document

The performances given in Section 3 are only valid if the screws are used in compliance with the specifications and conditions given in Annex 1 and 2.

Durability is only ensured if the specifications of intended use according to Annex 1 and 2 are taken into account.

The verifications and assessment methods on which this European Technical Assessment is based lead to the assumption of a working life of the screws of at least 50 years. The indications given on the working life cannot be interpreted as a guarantee given by the producer, but are to be regarded only as a means for choosing the right products in relation to the expected economically reasonable working life of the works.

3 Performance of the product and references to the methods used for its assessment

3.1 Mechanical resistance and stability (BWR 1)

Essential characteristic	Performance
Dimensions	See Annex 4
Characteristic yield moment	See Annex 2
Characteristic withdrawal parameter	See Annex 2
Characteristic head pull-through parameter	See Annex 2
Characteristic tensile strength	See Annex 2
Characteristic yield strength	See Annex 3
Characteristic torsional strength	See Annex 2
Insertion moment	See Annex 2
Spacing, end and edge distances of the screws and minimum thickness of the wood based material	See Annex 2
Slip modulus for mainly axially loaded screws	See Annex 2

3.2 Safety in case of fire (BWR 2)

Essential characteristic	Performance
Reaction to fire	Class A1

3.3 Safety and accessibility in use (BWR 4)

Same as BWR 1

English translation prepared by DIBt

4 Assessment and verification of constancy of performance (AVCP) system applied, with reference to its legal base

In accordance with EAD No. 130118-00-0603 the applicable European legal act is: 97/176/EC.
The system to be applied is: 3

5 Technical details necessary for the implementation of the AVCP system, as provided for in the applicable EAD

Technical details necessary for the implementation of the AVCP system are laid down in the control plan deposited with Deutsches Institut für Bautechnik.

Issued in Berlin on 7 August 2018 by Deutsches Institut für Bautechnik

Dr.-Ing. Lars Eckfeldt
p. p. Head of Department

beglaubigt:
Dewitt

Annex 1 Specifications of intended use

A.1.1 Use of Twin UD and PIR-FIX screws only for:

- Static and quasi-static loads

A.1.2 Base materials

The screws are used for connections in load bearing timber structures between wood-based members or between those members and steel members:

- Solid timber (softwood) according to EN 14081-1¹,
- Glued laminated timber (softwood) according to EN 14080²,
- Laminated veneer lumber LVL of softwood according to EN 14374³,
- Glued solid timber (softwood) according to EN 14080 or national provisions that apply at the installation site,
- Cross-laminated timber (softwood) according to European Technical Assessments or national provisions that apply at the installation site.

The screws may be used for connecting the following wood-based panels to the timber members mentioned above:

- Plywood according to EN 636⁴ and EN 13986⁵,
- Oriented Strand Board, OSB according to EN 300⁶ and EN 13986,
- Particleboard according to EN 312⁷ and EN 13986,
- Fibreboards according to EN 622-2⁸, EN 622-3⁹ and EN 13986,
- Cement-bonded particle boards according to EN 634-2¹⁰ and EN 13986,
- Solid-wood panels according to EN 13353¹¹ and EN 13986.

Wood-based panels shall only be arranged on the side of the screw head.

Twin UD and PIR-FIX screws may be used for the fixing of thermal insulation material on top of rafters or on wood-based members in vertical façades.

1	EN 14081-1:2005+A1:2011	Timber structures – Strength graded structural timber with rectangular cross section – Part 1: General requirements
2	EN 14080:2013	Timber structures - Glued laminated timber and glued solid timber - Requirements
3	EN 14374:2004	Timber structures - Structural laminated veneer lumber - Requirements
4	EN 636:2012+A1:2015	Plywood - Specifications
5	EN 13986:2004+A1:2015	Wood-based panels for use in construction - Characteristics, evaluation of conformity and marking
6	EN 300:2006	Oriented strand boards (OSB) – Definition, classification and specifications
7	EN 312:2010	Particleboards - Specifications
8	EN 622-2:2004	Fibreboards – Specifications – Part 2: Requirements for hardboards
9	EN 622-3:2004	Fibreboards - Specifications - Part 3: Requirements for medium boards
10	EN 634-2:2007	Cement-bonded particleboards – Specifications – Part 2: Requirements for OPC bonded particleboards for use in dry, humid and external conditions
11	EN 13353:2008+A1:2011	Solid wood panels (SWP) – Requirements

Screws Twin UD and PIR-FIX	Annex 1
Specifications of intended use	

A.1.3 Use Conditions (environmental conditions)

The corrosion protection of Twin UD and PIR-FIX screws is specified in Annex A.2.6. With regard to the use and the environmental conditions, the national provisions of the place of installation apply.

A.1.4 Installation provisions

EN 1995-1-1¹² in conjunction with the respective national annex applies for the installation.

A minimum of two screws shall be used for connections in load bearing timber structures. This does not apply for special situations specified in National Annexes to EN 1995-1-1.

The screws are driven into the wood-based member made of softwood without pre-drilling. Deviating from this provision the screws may be driven into battens in pre-drilled holes with a diameter of 5.0 mm.

In the case of fastening battens on thermal insulation material on top of rafters the screws shall be driven in the rafter through the battens and the thermal insulation material without pre-drilling in one sequence.

The screw holes in steel members shall be pre-drilled with an adequate diameter greater than the outer thread diameter.

The structural solid or glued laminated timber, laminated veneer lumber and similar glued members shall be from spruce, pine or fir.

¹² EN 1995-1-1: 2004+AC:2006+A1:2008+A2:2014 Eurocode 5: Design of timber structures – Part 1-1: General - Common rules and rules for buildings

Screws Twin UD and PIR-FIX	Annex 1
Installation provisions	

ANNEX 2 – Characteristic values of the load-carrying capacities

Table A.2.1 Characteristic load-carrying capacities of Twin UD and PIR-FIX screws

Nominal diameter [mm]		Twin UD and PIR-FIX
		7.5
Characteristic yield moment $M_{y,k}$ [Nm]		13.0
Characteristic tensile strength $f_{tens,k}$ [kN]		12.0
Characteristic torsional strength $f_{tor,k}$ [Nm]	Thread close to the head	23.0
	Thread close to the tip	13.0

A.2.1 General

The minimum penetration length of the threaded part of the screw in the wood-based members l_{ef} shall be

$$l_{ef} = \frac{4 \cdot d}{\sin \alpha} \quad (2.1)$$

where

- α angle between screw axis and grain direction
- d outer thread diameter of the screw.

The inner thread diameter d_1 of the screws shall be greater than the maximal width of the gaps in the layer of cross laminated timber.

A.2.2 Laterally loaded screws

The outer thread diameter d shall be used as effective diameter of the screw according to EN 1995-1-1.

The embedding strength for the screws in wood-based members or in wood-based panels shall be taken from EN 1995-1-1 or from national provisions that apply at the installation site unless otherwise specified in the following.

The embedding strength for screws in the edges of LVL shall be assumed as given in the technical specification of the LVL at the installation site.

A.2.3 Axially loaded screws

The axial slip modulus K_{ser} of the threaded part of a screw for the serviceability limit state shall be taken independent of angle α to the grain as:

$$K_{ser} = 780 \cdot d^{0,2} \cdot l_{ef}^{0,4} \quad [\text{N/mm}] \quad (2.2)$$

Where

- d outer thread diameter of the screw [mm]
- l_{ef} penetration length of the of the threaded part of the screw in the wood-based member [mm].

Screws Twin UD and PIR-FIX	Annex 2
Characteristic values of the load-carrying capacities	

A.2.3.1 Axial withdrawal capacity

The characteristic withdrawal parameter at an angle $\alpha = 90^\circ$ to the grain based on a characteristic density of the wood-based member ρ_a of 350 kg/m³ is

$$f_{ax,k} = 12.5 \text{ N/mm}^2.$$

The characteristic withdrawal parameter for LVL shall be assumed as given in the technical specification of the LVL at the installation site.

For LVL a maximum characteristic density of 500 kg/m³ shall be used in equation (8.40a) of EN 1995-1-1.

For screws penetrating more than one layer of cross-laminated timber the different layers may be taken into account proportionally. In the lateral surfaces of the cross-laminated timber the screws shall be fully inserted in one layer.

The characteristic withdrawal parameter of the wood-based panels mentioned below at an angle $\alpha = 90^\circ$ is

$$f_{ax,k} = 10.0 \text{ N/mm}^2 \text{ for Twin UD and PIR-FIX screws.}$$

This axial withdrawal capacity applies to:

- Plywood according to EN 636 and EN 13986 with a characteristic density of at least 400 kg/m³,
- Particle board according to EN 312 and EN 13986 of at least technical class P4,
- OSB/3 and OSB/4 according to EN 300 and EN 13986.

A.2.3.2 Head pull-through capacity

For Twin UD and PIR-FIX screws the withdrawal capacity of the thread in the wood-based member with the screw head shall be taken into account.

A.2.4 Spacing, end and edge distances of the screws and minimum thickness of the wood based material

Minimum thickness for structural members is $t = 30 \text{ mm}$.

A.2.4.1 Laterally and/or axially loaded screws

Screws in pre-drilled holes in battens

Pre-drilling is only allowed in battens. For Twin UD and PIR-FIX screws in pre-drilled holes in battens the minimum spacings, end and edge distances are given in EN 1995-1-1, clause 8.3.1.2 and Table 8.2 as for nails in pre-drilled holes. Here, the outer thread diameter d of the thread close to the head shall be considered.

Screws in non pre-drilled holes

For Twin UD and PIR-FIX screws minimum spacing and distances are given in EN 1995-1-1, clause 8.3.1.2 and Table 8.2 as for nails in non-predrilled holes. Here, the outer thread diameter d shall be considered.

For Douglas fir members minimum spacing and distances parallel to the grain shall be increased by 50%.

Minimum distances from loaded or unloaded ends shall be at least $15 \cdot d$ for timber thickness $t < 5 \cdot d$.

A.2.4.2 Only axially loaded screws

For Twin UD and PIR-FIX screws the minimum spacings, end and edge distances are given in EN 1995-1-1, clause 8.3.1.2 and Table 8.2 as for nails in non-predrilled holes and clause 8.7.2, Table 8.6.

Screws Twin UD and PIR-FIX	Annex 2
Characteristic values of the load-carrying capacities and spacing, end and edge distances	

A.2.5 Insertion moment

The ratio between the characteristic torsional strength $f_{tor,k}$ and the mean value of insertion moment $R_{tor,mean}$ fulfills the requirement for all screws.

A.2.6 Durability against corrosion

Screws made from carbon steel may have the coatings according to Table A.2.3

Table A.2.3 Coatings of the Twin UD and PIR-FIX screws

Coating		Minimum thickness of the coating [μm]
Durocoat	DP1	5
	T	
	WB	
Electrolytically galvanised		5
Hot dip zinc coating		55
Zinc-nickel coating (HP coating)		5

Screws Twin UD and PIR-FIX	Annex 2
Insertion moment and durability against corrosion	

ANNEX 3 - Fastening of thermal insulation material on top of rafters

A.3.1 General

Twin UD and PIR-FIX screws may be used for the fixing of thermal insulation material on top of rafters or on wood-based members in vertical façades. In the following, the meaning of the word rafter includes wood-based members with inclinations between 0° and 90°.

The thickness of the thermal insulation material may be up to 400 mm. The thermal insulation material shall be applicable as insulation on top of rafters or for façades according to national provisions that apply at the installation site.

The battens have to be from solid timber according to EN 14081-1. The minimum thickness t and the minimum width b of the battens are given in table A.3.1:

Table A.3.1 Minimum thickness and minimum width of the battens

Outer thread diameter [mm]	Minimum thickness t [mm]	Minimum width b [mm]
7.5	40	60

Instead of battens the wood-based panels specified in chapter A.3.2.1 may be used.

The minimum width of the rafters shall be 60 mm.

The spacing between screws shall be not more than 1.75 m.

Friction forces shall not be considered for the design of the characteristic axial load of the screws.

The anchorage of wind suction forces as well as the bending stresses of the battens shall be considered for design. Screws perpendicular to the grain of the rafter (angle $\alpha = 90^\circ$) may be arranged where required considering the design of the battens.

A.3.2 Parallel inclined screws and thermal insulation material in compression

A.3.2.1 Mechanical model

The system of rafter, thermal insulation material on top of rafter and counter battens parallel to the rafter may be considered as a beam on elastic foundation. The counter batten represents the beam, and the thermal insulation material on top of the rafter the elastic foundation. The minimum compressive stress of the thermal insulation material at 10 % deformation, measured according to EN 826¹³, shall be $\sigma_{(10\%)} = 0.05 \text{ N/mm}^2$. The counter batten is loaded perpendicular to the axis by point loads F_b transferred by regularly spaced battens. Further point loads F_s are caused by the shear load of the roof due to dead and snow load, which are transferred from the screw heads into the counter battens.

Instead of battens the following wood-based panels may be used to cover the thermal insulation material if they are suitable for that use:

- Plywood according to EN 636 and EN 13986,
- Oriented Strand Board, OSB according to EN 300 and EN 13986,
- Particleboard according to EN 312 and EN 13986,
- Fibreboards according to EN 622-2, EN 622-3 and EN 13986,
- Laminated veneer lumber according to EN 14374.

The minimum thickness of the wood-based panels shall be 22 mm.

The word batten includes the meaning of wood-based panels in the following.

¹³ EN 826:2013 Thermal insulating products for building applications - Determination of compression behaviour

Screws Twin UD and PIR-FIX	Annex 3
Fastening of thermal insulation material on top of rafters	

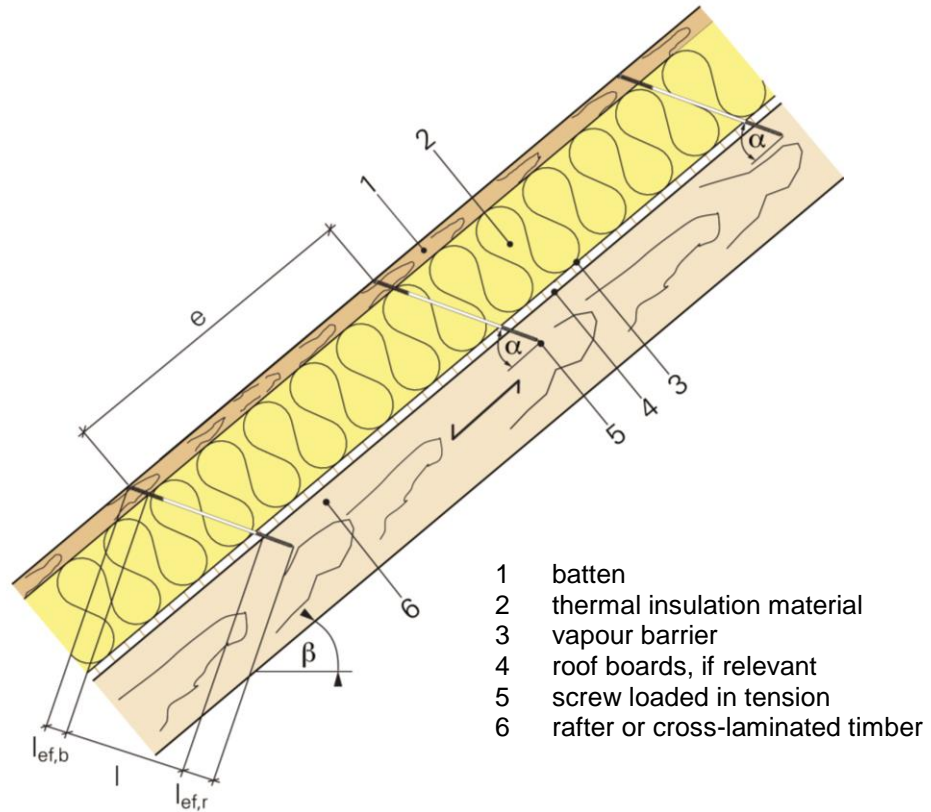

- 1 batten
- 2 thermal insulation material
- 3 vapour barrier
- 4 roof boards, if relevant
- 5 screw loaded in tension
- 6 rafter or cross-laminated timber

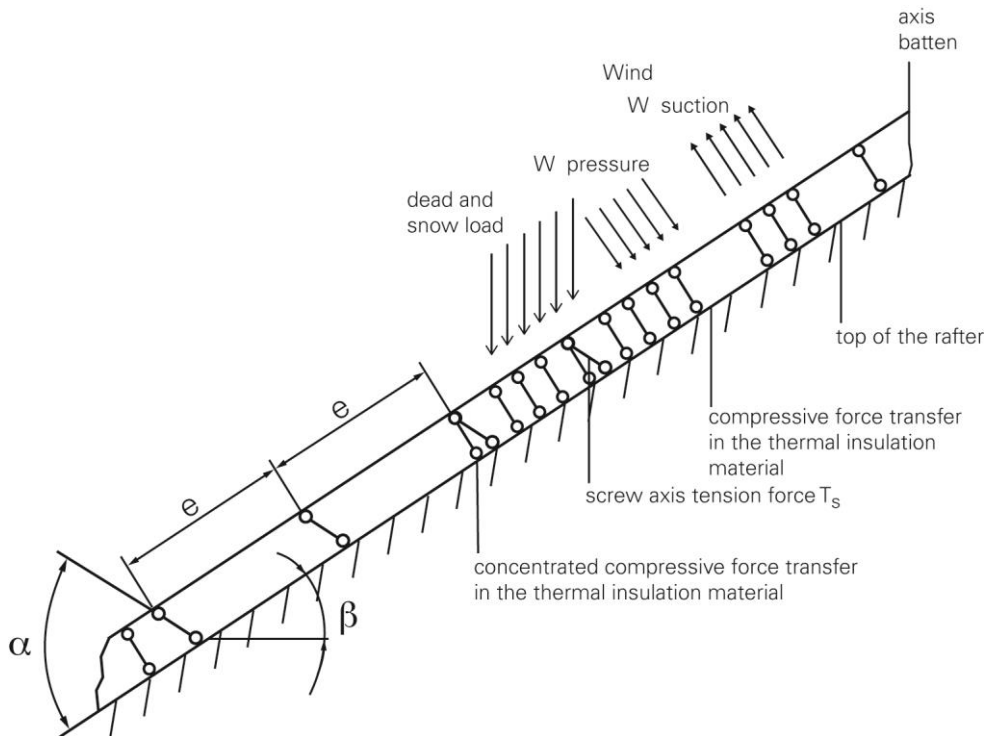

Figure A.3.1 Fastening of the thermal insulation material on top of rafters - structural system

Screws Twin UD and PIR-FIX	Annex 3
Fastening of thermal insulation material on top of rafters	

electronic copy of the eta by dibt: eta-12/0038

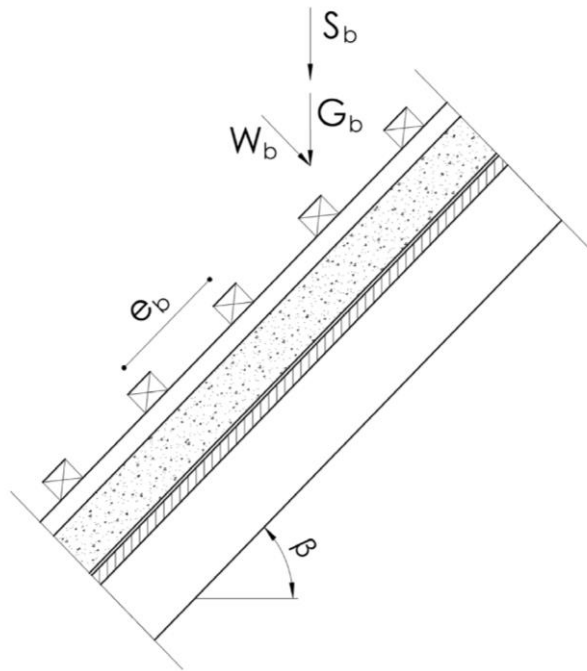

Figure A.3.2 Point loads F_b perpendicular to the battens

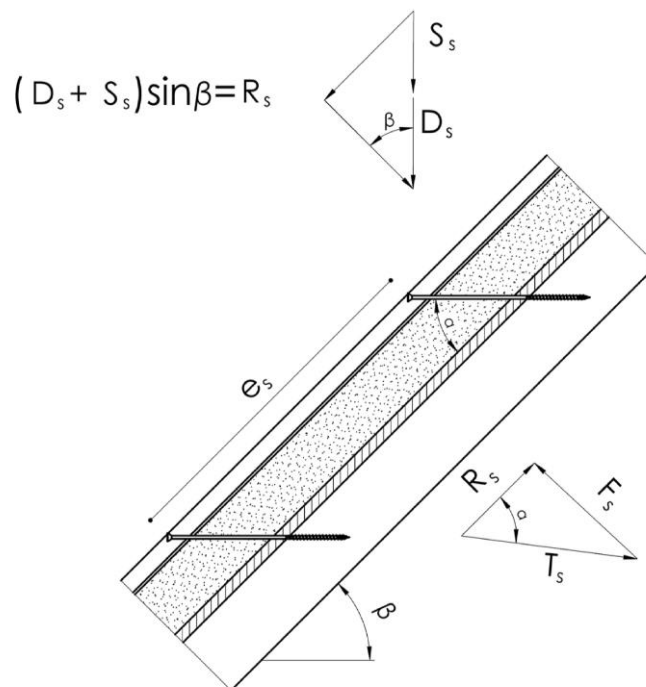

Figure A.3.3 Point loads F_s perpendicular to the battens, load application in the area of the screw heads

electronic copy of the eta by dibt: eta-12/0038

Screws Twin UD and PIR-FIX	Annex 3
Fastening of thermal insulation material on top of rafters	

A.3.2.2 Design of the battens

It's assumed that the spacing between the counter battens exceeds the characteristic length l_{char} .

The characteristic values of the bending stresses are calculated as:

$$M_k = \frac{(F_{b,k} + F_{s,k}) \cdot l_{char}}{4} \quad (3.1)$$

where

$$l_{char} = \text{characteristic length } l_{char} = \sqrt[4]{\frac{4 \cdot EI}{w_{ef} \cdot K}} \quad (3.2)$$

EI = bending stiffness of the batten

K = coefficient of subgrade

w_{ef} = effective width of the thermal insulation material

$F_{b,k}$ = point loads perpendicular to the battens

$F_{s,k}$ = point loads perpendicular to the battens, load application in the area of the screw heads

The coefficient of subgrade K may be calculated from the modulus of elasticity E_{HI} and the thickness t_{HI} of the thermal insulation material if the effective width w_{ef} of the thermal insulation material under compression is known. Due to the load extension in the thermal insulation material the effective width w_{ef} is greater than the width of the batten or rafter, respectively. For further calculations, the effective width w_{ef} of the thermal insulation material may be determined according to:

$$w_{ef} = w + t_{HI} / 2 \quad (3.3)$$

where

w = minimum from width of the batten or rafter, respectively

t_{HI} = thickness of the thermal insulation material

$$K = \frac{E_{HI}}{t_{HI}} \quad (3.4)$$

The following condition shall be satisfied:

$$\frac{\sigma_{m,d}}{f_{m,d}} = \frac{M_d}{W \cdot f_{m,d}} \leq 1 \quad (3.5)$$

For the calculation of the section modulus W the net cross section shall be considered.

The characteristic values of the shear stresses shall be calculated according to:

$$V_k = \frac{(F_{b,k} + F_{s,k})}{2} \quad (3.6)$$

The following condition need to be satisfied:

$$\frac{\tau_d}{f_{v,d}} = \frac{1.5 \cdot V_d}{A \cdot f_{v,d}} \leq 1 \quad (3.7)$$

For the calculation of the cross section area the net cross section shall be considered.

Screws Twin UD and PIR-FIX	Annex 3
Fastening of thermal insulation material on top of rafters	

A.3.2.3 Design of the thermal insulation material

The characteristic value of the compressive stresses in the thermal insulation material shall be calculated according to:

$$\sigma_k = \frac{1.5 \cdot F_{b,k} + F_{s,k}}{2 \cdot l_{char} \cdot W} \quad (3.8)$$

The design value of the compressive stress shall not be greater than 110 % of the compressive strength at 10 % deformation calculated according to EN 826.

A.3.2.4 Design of the screws

The screws are loaded predominantly axial. The characteristic value of the axial tension force in the screw may be calculated from the shear loads of the roof $R_{S,k}$:

$$T_{S,k} = \frac{R_{S,k}}{\cos \alpha} \quad (3.9)$$

The load-carrying capacity of axially loaded screws is the minimum design value of the axial withdrawal capacity of the threaded part of the screw, the head pull-through capacity of the screw and the tensile capacity of the screw according to Annex 2.

In order to limit the deformation of the screw head for thermal insulation material with thickness over 220 mm or with compressive strength below 0.12 N/mm², respectively, the axial withdrawal capacity of the screws shall be reduced by the factors k_1 and k_2 :

$$F_{ax,\alpha,Rd} = \min \left\{ \frac{f_{ax,d} \cdot d \cdot l_{ef,r} \cdot k_1 \cdot k_2}{1.2 \cdot \cos^2 \alpha + \sin^2 \alpha} \cdot \left(\frac{\rho_k}{350} \right)^{0.8}; \frac{f_{ax,d} \cdot d \cdot l_{ef,b}}{1.2 \cdot \cos^2 \alpha + \sin^2 \alpha} \cdot \left(\frac{\rho_k}{350} \right)^{0.8}; \frac{f_{tens,k}}{\gamma_{M2}} \right\} \quad (3.10)$$

where:

- $f_{ax,d}$ design value of the axial withdrawal capacity of the threaded part of the screw [N/mm²],
 $f_{ax,d} = k_{mod} \cdot f_{ax,k} / \gamma_M$
- $f_{ax,k}$ characteristic value of the axial withdrawal capacity of the threaded part of the screw [N/mm²]
- k_{mod} modification factor for duration of load and moisture content according to EN 1995-1-1 in conjunction with the particular national annex
- γ_M Partial factor for material properties according to EN 1995-1-1 in conjunction with the particular national annex
- d outer thread diameter of the screw [mm]
- $l_{ef,r}$ penetration length of the threaded part of the screw in the rafter, $l_{ef} \geq 40$ mm
- $l_{ef,b}$ penetration length of the threaded part of the screw in the batten or in the wood-based panel [mm]
- ρ_k characteristic density of the wood-based member [kg/m³], for wood-based panels $\rho_k = 350$ kg/m³, for LVL $\rho_k \leq 500$ kg/m³
- α angle α between screw axis and grain direction, $30^\circ \leq \alpha \leq 90^\circ$
- $f_{tens,k}$ characteristic tensile capacity of the screw according to Annex 2 [N]
- γ_{M2} partial factor according to EN 1993-1-1 in conjunction with the particular national annex
- k_1 $\min \{1; 220/t_{HI}\}$
- k_2 $\min \{1; \sigma_{10\%}/0.12\}$
- t_{HI} thickness of the thermal insulation material [mm]
- $\sigma_{10\%}$ compressive stress of the thermal insulation material under 10 % deformation [N/mm²]

If equation (3.10) is fulfilled, the deflection of the battens does not need to be considered when designing the load-carrying capacity of the screws.

Screws Twin UD and PIR-FIX	Annex 3
Fastening of thermal insulation material on top of rafters	

A.3.3 Alternatively inclined screws and thermal insulation material non in compression

A.3.3.1 Mechanical model

Depending on the screw spacing and the arrangement of tensile and compressive screws with different inclinations the battens are loaded by significant bending moments. The bending moments are derived based on the following assumptions:

- The tensile and compressive loads in the screws are determined based on equilibrium conditions from the actions parallel and perpendicular to the roof plane. These actions are constant line loads q_{\perp} and q_{\parallel} .
- The screws act as hinged columns supported 10 mm within the batten or rafter, respectively. The effective column length consequently equals the length of the screw between batten and rafter plus 20 mm.
- The batten is considered as a continuous beam with a constant span $\ell = A + B$. The compressive screws constitute the supports of the continuous beam while the tensile screws transfer concentrated loads perpendicular to the batten axis.

The screws are predominantly loaded in withdrawal or compression, respectively. The characteristic values of the screw's normal forces are determined based on the loads parallel and perpendicular to the roof plane:

$$\text{Compressive screw: } N_{c,k} = (A+B) \cdot \left(-\frac{q_{\parallel,k} \cdot \sin \alpha_2 + q_{\perp,k} \cdot \cos \alpha_2}{\sin(\alpha_1 + \alpha_2)} \right) \quad (3.11)$$

$$\text{Tensile screw: } N_{t,k} = (A+B) \cdot \left(\frac{q_{\parallel,k} \cdot \sin \alpha_1 - q_{\perp,k} \cdot \cos \alpha_1}{\sin(\alpha_1 + \alpha_2)} \right) \quad (3.12)$$

- A distance of the screws according to Figure 3.5
 B distance of the alternatively inclined screws according to Figure 3.5
 $q_{\parallel,k}$ characteristic value of the loads parallel to the roof plane
 $q_{\perp,k}$ characteristic value of the loads perpendicular to the roof plane
 α angle α_1 and α_2 between screw axis and grain direction, $30^\circ \leq \alpha_1 \leq 90^\circ$, $30^\circ \leq \alpha_2 \leq 90^\circ$

The bending moments in the batten follow from the constant line load q_{\perp} and the load components perpendicular to the batten from the tensile screws. The span of the continuous beam is $(A + B)$. The characteristic value of the load component perpendicular to the batten from the tensile screw is:

$$F_{zs,k} = (A+B) \cdot \left(\frac{q_{\parallel,k} \cdot \sin \alpha_1 \cdot \sin \alpha_2 - q_{\perp,k} \cdot \cos \alpha_1 \cdot \sin \alpha_2}{\sin(\alpha_1 + \alpha_2)} \right) \quad (3.13)$$

A positive value for $F_{zs,k}$ means a load towards the rafter, a negative value a load away from the rafter. The system of the continuous beam is shown in Figure 3.5.

The battens or wood-based panels fixed on the rafter shall be supported perpendicular to the load-bearing plane.

Screws Twin UD and PIR-FIX	Annex 3
Fastening of the thermal insulation material on top of rafters	

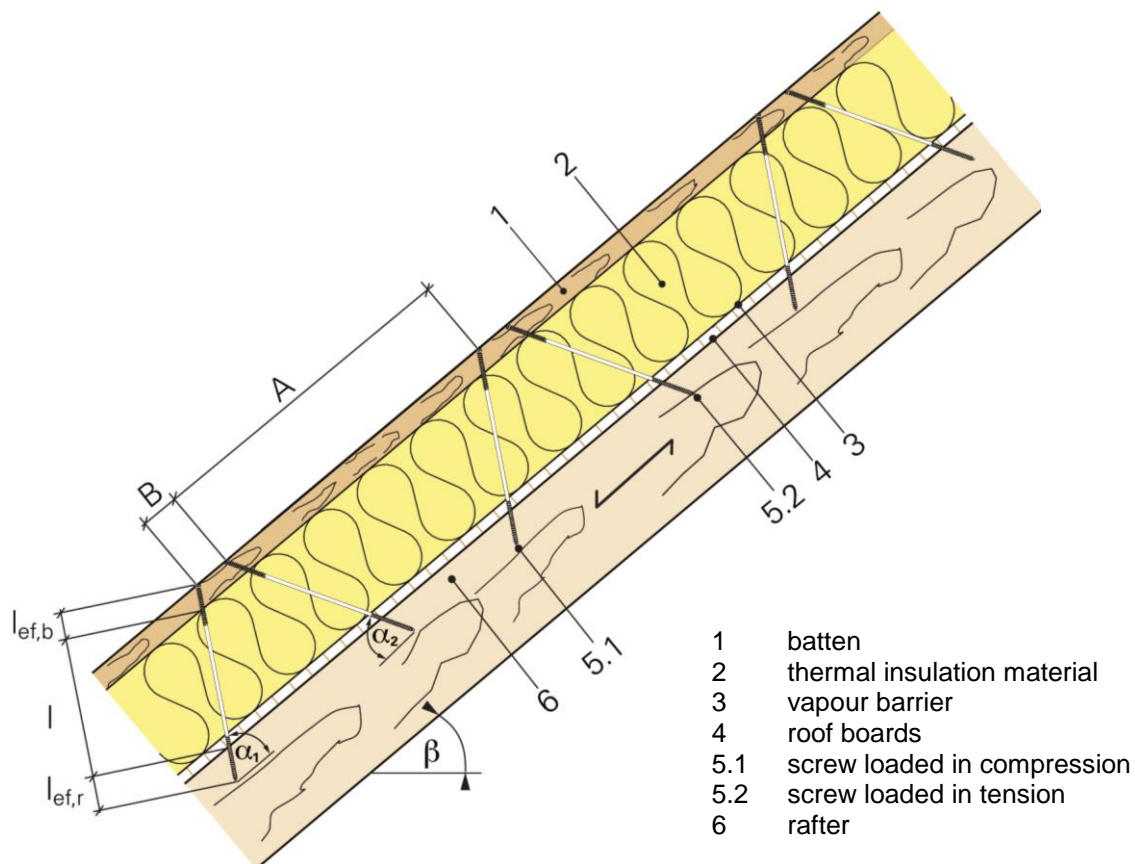

Figure 3.4 Fastening of thermal insulation material on top of rafters - structural system for alternatively inclined screws

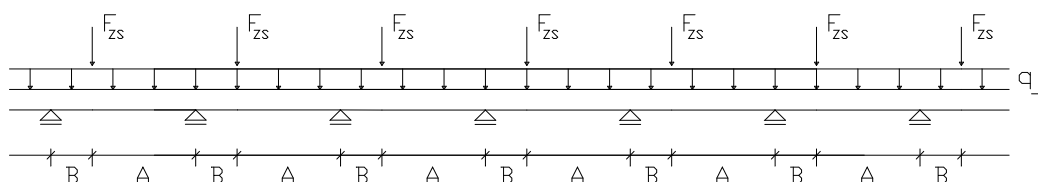

Figure 3.5: Continuous batten under constant line loads from actions on the roof plane q_{\perp} and concentrated loads from tensile screws F_{zs}

electronic copy of the eta by dibt: eta-12/0038

Screws Twin UD and PIR-FIX	Annex 3
Fastening of the thermal insulation material on top of rafters	

A.3.3.2 Design of the screws

The design value of the load-carrying capacity of the screws shall be calculated according to equation (3.14) and (3.15).

Screws loaded in tension:

$$F_{ax,\alpha,Rd} = \min \left\{ \frac{f_{ax,d} \cdot d \cdot l_{ef,b}}{1.2 \cdot \cos^2 \alpha_2 + \sin^2 \alpha_2} \cdot \left(\frac{\rho_{b,k}}{350} \right)^{0.8}; \frac{f_{ax,d} \cdot d \cdot l_{ef,r}}{1.2 \cdot \cos^2 \alpha_2 + \sin^2 \alpha_2} \cdot \left(\frac{\rho_{r,k}}{350} \right)^{0.8}; \frac{f_{tens,k}}{\gamma_{M2}} \right\} \quad (3.14)$$

Screws loaded in compression:

$$F_{ax,\alpha,Rd} = \min \left\{ \frac{f_{ax,d} \cdot d \cdot l_{ef,b}}{1.2 \cdot \cos^2 \alpha_1 + \sin^2 \alpha_1} \cdot \left(\frac{\rho_{b,k}}{350} \right)^{0.8}; \frac{f_{ax,d} \cdot d \cdot l_{ef,r}}{1.2 \cdot \cos^2 \alpha_1 + \sin^2 \alpha_1} \cdot \left(\frac{\rho_{r,k}}{350} \right)^{0.8}; \frac{\kappa_c \cdot N_{pl,k}}{\gamma_{M1}} \right\} \quad (3.15)$$

where:

- $f_{ax,d}$ design value of the axial withdrawal capacity of the threaded part of the screw [N/mm²],
 $f_{ax,d} = k_{mod} \cdot f_{ax,k} / \gamma_M$
- $f_{ax,k}$ characteristic value of the axial withdrawal capacity of the threaded part of the screw [N/mm²]
- k_{mod} modification factor for duration of load and moisture content according to EN 1995-1-1 in conjunction with the particular national annex
- γ_M Partial factor for material properties according to EN 1995-1-1 in conjunction with the particular national annex
- d outer thread diameter of the screw [mm]
- $l_{ef,b}$ penetration length of the threaded part of the screw in the batten [mm]
- $l_{ef,r}$ penetration length of the threaded part of the screw in the rafter, $l_{ef} \geq 40$ mm
- $\rho_{b,k}$ characteristic density of the batten [kg/m³]
- $\rho_{r,k}$ characteristic density of the rafter [kg/m³]
- α angle α_1 or α_2 between screw axis and grain direction, $30^\circ \leq \alpha_1 \leq 90^\circ$, $30^\circ \leq \alpha_2 \leq 90^\circ$
- $f_{tens,k}$ characteristic tensile capacity of the screw according to Annex 2 [N]
- γ_{M1}, γ_{M2} partial factor according to EN 1993-1-1 in conjunction with the particular national annex
- $\kappa_c \cdot N_{pl,k}$ Buckling capacity of the screw according to table 3.2 [N]

Screws Twin UD and PIR-FIX	Annex 3
Fastening of the thermal insulation material on top of rafters	

Table 3.2 Characteristic load-carrying capacity of the screws $\kappa_c \cdot N_{pl,k}$ in kN

Free screw length between batten and rafter [mm]	Twin UD and PIR-FIX screws	
	Outer thread diameter d [mm]	
	7.5 / 8.8	
	$\kappa_c \cdot N_{pl,k}$ [kN]	
≤ 100	10.1	
120	8.3	
140	6.8	
160	5.7	
180	4.8	
200	4.1	
220	3.5	
240	3.0	
260	2.7	
280	2.3	
300	2.1	
320	1.9	
340	1.7	
360	1.5	
380	1.4	
400	1.3	
420	1.2	
440	1.1	
460	1.0	
480	0.9	

Screws Twin UD and PIR-FIX	Annex 3
Fastening of the thermal insulation material on top of rafters	

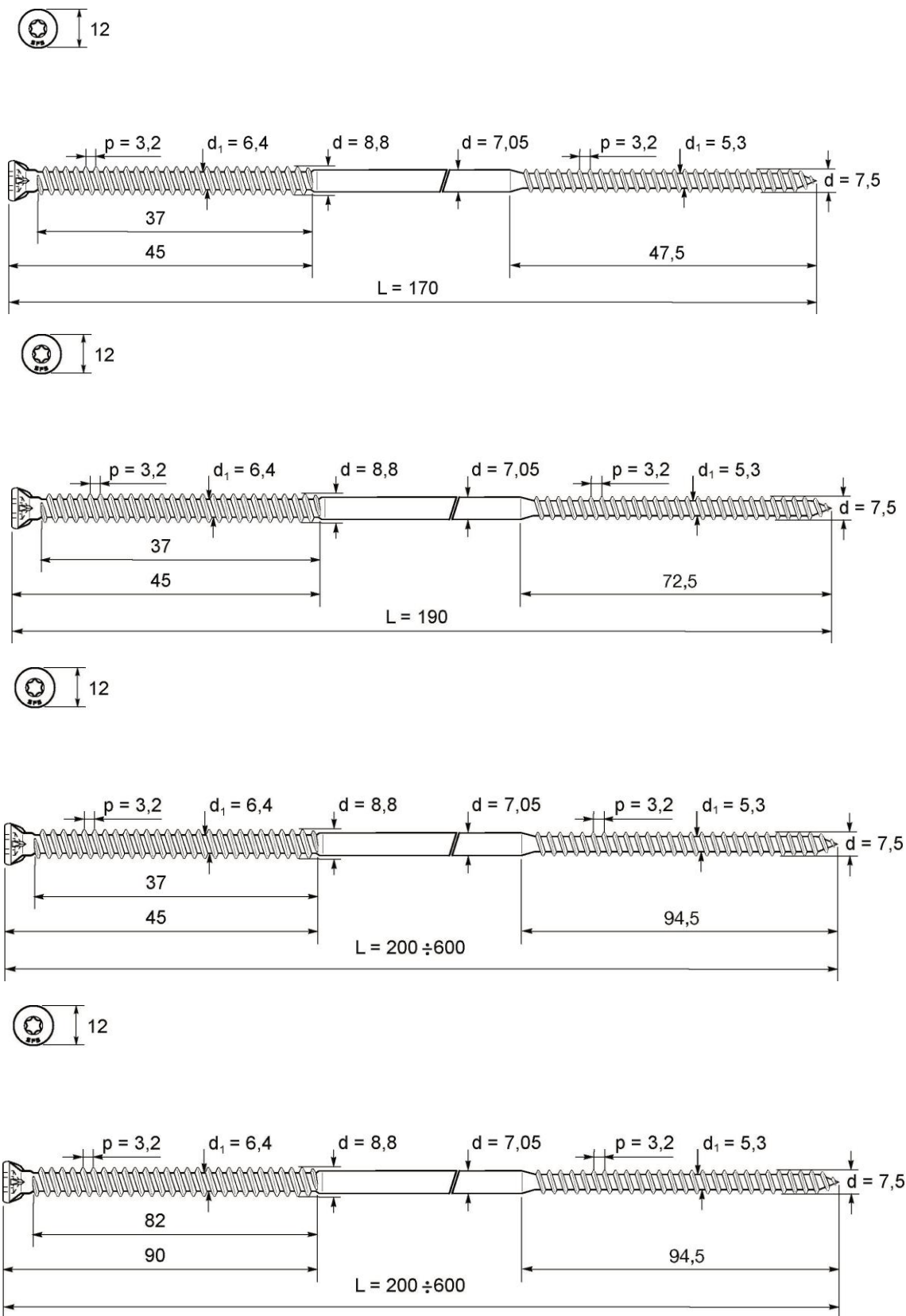

Screws Twin UD and PIR-FIX

Twin UD screws

Annex 4.1

Alternative screw heads

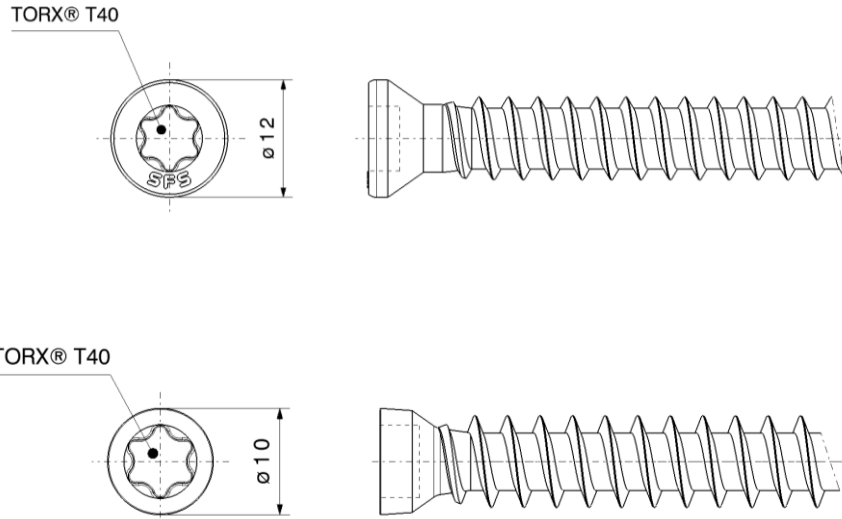

Alternative screw tips

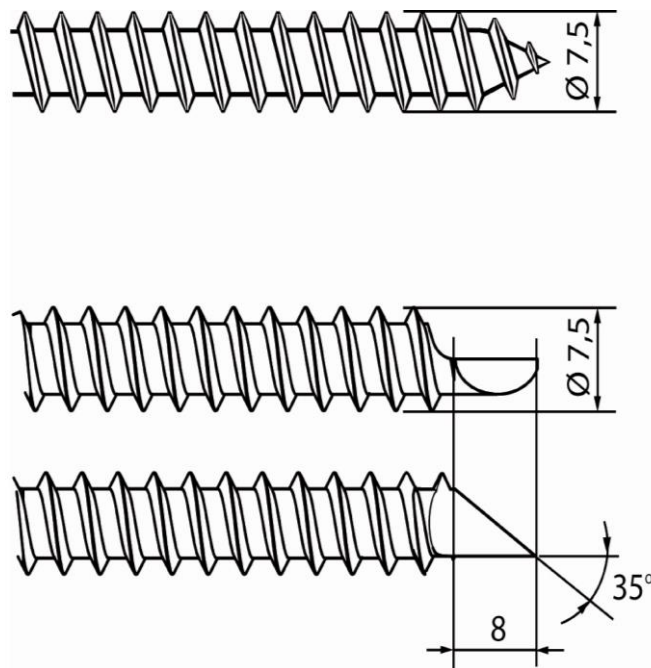

Screws Twin UD and PIR-FIX

Twin UD screws – Alternative screw heads and screw tips

Annex 4.2

Alternative rough thread in the area of the shank

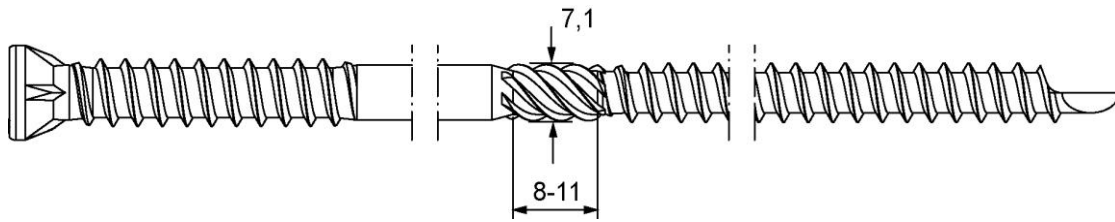

electronic copy of the eta by dibt: eta-12/0038

Screws Twin UD and PIR-FIX

Twin UD screws - Alternative rough thread in the area of the shank

Annex 4.3

English translation prepared by DIBt

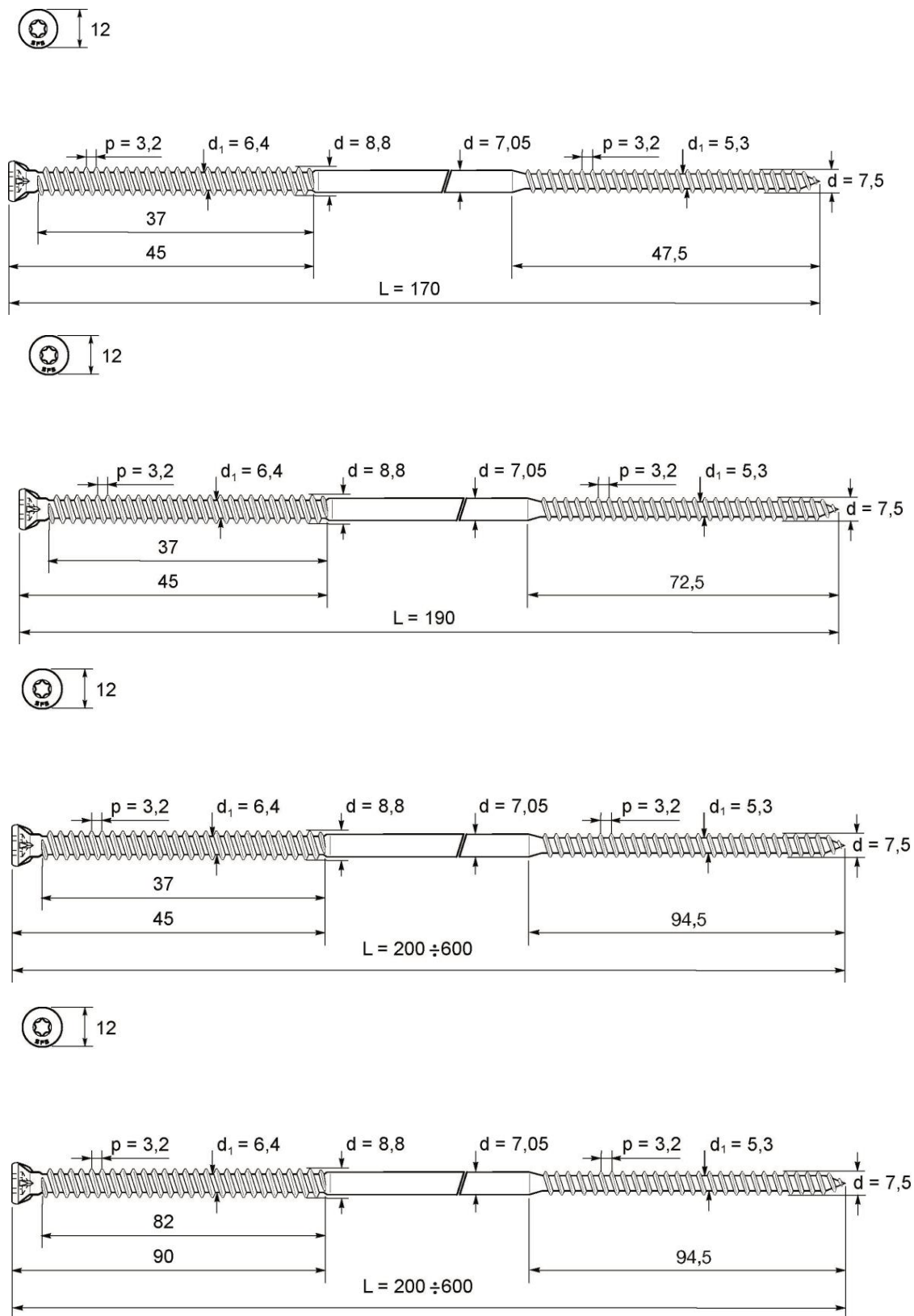

Alternative screw heads, screw tips and rough thread are similar to Twin UD screws

Screws Twin UD and PIR-FIX

PIR-FIX screws

Annex 4.4