

Approval body for construction products
and types of construction

Bautechnisches Prüfamt

An institution established by the Federal and
Laender Governments



European Technical Assessment

ETA-12/0561
of 21 December 2017

English translation prepared by DIBt - Original version in German language

General Part

Technical Assessment Body issuing the
European Technical Assessment:

Deutsches Institut für Bautechnik

Trade name of the construction product

StoTherm Vario 7

Product family
to which the construction product belongs

Product area code: 4
External Thermal Insulation Composite System with
rendering on mineral wool for the use as external
insulation of building walls

Manufacturer

Sto SE & Co. KGaA
Ehrenbachstraße 1
79780 Stühlingen
DEUTSCHLAND

Manufacturing plant

Sto SE & Co. KGaA
Ehrenbachstraße 1
79780 Stühlingen
DEUTSCHLAND

This European Technical Assessment
contains

20 pages including 4 annexes which form an integral part
of this assessment

Annex 5 Control Plan contains confidential information
and is not included in the European Technical
Assessment when the assessment is publicly available.

This European Technical Assessment is
issued in accordance with Regulation (EU)
No 305/2011, on the basis of

ETAG 004, edition 2000, amended 2013,
used as EAD according to Article 66 Paragraph 3 of
Regulation (EU) No 305/2011.

The European Technical Assessment is issued by the Technical Assessment Body in its official language. Translations of this European Technical Assessment in other languages shall fully correspond to the original issued document and shall be identified as such.

Communication of this European Technical Assessment, including transmission by electronic means, shall be in full. However, partial reproduction may only be made with the written consent of the issuing Technical Assessment Body. Any partial reproduction shall be identified as such.

This European Technical Assessment may be withdrawn by the issuing Technical Assessment Body, in particular pursuant to information by the Commission in accordance with Article 25(3) of Regulation (EU) No 305/2011.

Specific Part

1 Technical description of the product

1.1 Definition of the kit

This product is an External Thermal Insulation Composite System (ETICS) with rendering - a kit comprising components which are factory-produced by the manufacturer or component suppliers. It's made up on site from these. The ETICS manufacturer is ultimately responsible for all components of the ETICS specified in this ETA. The ETICS kit comprises a prefabricated insulation product of expanded polystyrene (EPS) to be bonded and if it necessary additional mechanically fixed onto a wall. The methods of fixing and the relevant components are specified in the table below.

The insulation product is faced with a rendering system consisting of one base coat and finishing coat (site applied), in which the base coat contains reinforcement. The rendering is applied directly to the insulating panels, without any air gap or disconnecting layer.

The ETICS may include special fittings (e.g. base profiles, corner profiles ...) for connection to adjacent building elements (apertures, corners, parapets...). Assessment and performance of these components is not addressed in this ETA, however the ETICS manufacturer is responsible for adequate compatibility and performance within the ETICS when the components are delivered as a part of the kit.

1.2 Composition of the ETICS

	Components	Coverage [kg/m ²]	Thickness [mm]
	National application documents shall be taken into account		
Insulation material with associated method of fixing	Bonded ETICS:		
	• Insulation product (see Annex 1 for product characteristics) factory-prefabricated expanded polystyrene (EPS)		
	- standard-EPS	–	≤ 400
	- elastified EPS	–	≤ 200
	• Adhesives (minimum bonded surface 40 %)		
	- StoLevell FT (cement based powder requiring addition of 28 % of water)	4.0 to 7.5 (powder)	–
	- StoLevell Uni (cement based powder requiring addition of 24 - 26 % of water)	3.0 to 7.5 (powder)	–
	- StoLevell Duo Plus (cement based powder requiring addition of 25 % of water)	4.0 to 7.5 (powder)	–
	- StoColl IP (cement based powder requiring addition of 20 % of water)	4.0 to 5.0 (powder)	–
	- StoLevell Alpha (cement based powder requiring addition of about (25 - 28) % of water)	4.0 to 7.5 (powder)	–
- Sto-Baukleber (cement based powder requiring addition of 22 - 26 % water)	3.0 to 7.5 (powder)	–	
- Sto-Dispersionskleber (organic based ready to use paste)	1.0 to 1.5 (prepared)	–	

	Components National application documents shall be taken into account	Coverage [kg/m ²]	Thickness [mm]
Insulation material with associated method of fixing	Mechanically fixed ETICS with profiles and supplementary adhesive: <ul style="list-style-type: none"> • Insulation product (see annex 1 for product characteristics) factory-prefabricated expanded polystyrene (EPS) <ul style="list-style-type: none"> - standard-EPS • Supplementary adhesives (equal to bonded ETICS) • Profiles <ul style="list-style-type: none"> - "Sto-Halteleiste PVC" and - "Sto-Verbindungsleiste PVC" Polyvinylchlorid (PVC) profiles • Anchors for profiles (see annex 2 for product characteristics) <ul style="list-style-type: none"> - WS 8 L - WS 8 N - ejothem SDK U - SDF-K plus - ejothem NKU 	-	60 to 200
	Mechanically fixed ETICS with anchors and supplementary adhesive: <ul style="list-style-type: none"> • Insulation product (see annex 1 for product characteristics) Factory-prefabricated expanded polystyrene <ul style="list-style-type: none"> - standard-EPS - elastified EPS • Supplementary adhesives (equal to bonded ETICS) • Anchors for insulation product all anchors with ETA according to EAD 330196-00-0604¹ with characteristics defined in annex 2 	- -	60 to 400 60 to 200
Base coat	StoLevel FT Identical with the equally named adhesive given above.	4.0 to 5.0 (powder)	3.0 to 4.0
Glass fibre mesh	(see annex 4 for product characteristics)		
	Sto-Glasfasergewebe Alkali- and slide-resistant glass fibre mesh with mass per unit area of about 165 g/m ² and mesh size of about 6.0 mm x 6.0 mm	-	-
	Sto-Glasfasergewebe F Alkali- and slide-resistant glass fibre mesh with mass per unit area of about 165 g/m ² and mesh size of about 4.0 mm x 4.0 mm	-	-

¹ EAD 330196-00-0604

Plastic anchors for fixing of external thermal insulation composite systems with rendering

	Components National application documents shall be taken into account	Coverage [kg/m ²]	Thickness [mm]
	Sto-Panzergerewebe (reinforced mesh implemented in addition to the mesh described above to improve the impact resistance) Alkali- and slide-resistant glass fibre mesh with mass per unit area of about 450 g/m ² and mesh size of about 4.0 mm x 4.0 mm.	–	–
Key coat	StoPrep Miral Sto-Putzgrund Sto-Putzgrund QS StoPrep QS Ready to use pigmented acrylic- resin dispersion liquids. StoPrep Miral with additional potassium silicate binder. To be used with finishing coats indicated hereafter.	} 0.3 to 0.4	–
Finishing coat	To use with key coat "Sto-Putzgrund", if applicable:* <ul style="list-style-type: none"> Ready to use paste - acrylic binder: <ul style="list-style-type: none"> Stolit K (particle size 1.0 to 6.0 mm) Stolit R (particle size 1.5 to 6.0 mm) Stolit Effect (particle size 3.0 mm) Stolit MP (thin, middle or thick layer) StoMarlit K (particle size 1.5 to 3.0 mm) StoMarlit R (particle size 1.5 to 3.0 mm) StoLotusan K (particle size 1.0 to 3.0 mm) StoLotusan MP (thin, middle or thick layer) To use with key coat "Sto-Putzgrund"/"StoPrep Miral" if applicable:* <ul style="list-style-type: none"> Ready to use pastes - acrylic binder: <ul style="list-style-type: none"> StoSilco K (particle size 1.0 to 3.0 mm) StoSilco R (particle size 1.5 to 3.0 mm) StoSilco MP (thin, middle or thick layer) To use with key coat "Sto-Putzgrund QS"/"StoPrep QS", if applicable:* <ul style="list-style-type: none"> Ready to use pastes – acrylic binder (application between 0 °C and 15 °C): <ul style="list-style-type: none"> Stolit QS K (particle size 1.0 to 3.0 mm) Stolit QS R (particle size 1.5 to 3.0 mm) Stolit QS MP (thin, middle or thick layer) Ready to use pastes - acrylic/siloxane binder (application between 0 °C and 15 °C): <ul style="list-style-type: none"> StoSilco QS K (particle size 1.0 to 3.0 mm) StoSilco QS R (particle size 1.5 to 3.0 mm) StoSilco QS MP (thin, middle or thick layer) To use with key coat "StoPrep Miral". if applicable: * <ul style="list-style-type: none"> Ready to use pastes - silicate binder: <ul style="list-style-type: none"> StoSil K (particle size 1.0 to 3.0 mm) StoSil R (particle size 1.5 to 3.0 mm) StoSil MP (thin, middle or thick layer) 	2.0 to 6.5 2.2 to 6.1 4.5 to 5.5 2.2 to 4.7 2.6 to 4.9 2.5 to 4.4 2.0 to 5.0 2.2 to 4.7 2.0 to 5.0 2.9 to 4.9 2.2 to 4.7 2.0 to 4.8 2.2 to 4.5 2.2 to 4.7 2.0 to 5.0 2.9 to 4.5 2.2 to 4.7 2.2 to 4.4 2.4 to 3.9 1.5 to 4.0	} Regulated by particle size } 1.5 to 3.5 regulated by particle size } 1.5 to 3.5 } regulated by particle size } 1.5 to 3.5 } regulated by particle size } 1.5 to 3.5 } regulated by particle size } 1.5 to 3.5

	Components National application documents shall be taken into account	Coverage [kg/m ²]	Thickness [mm]
	<ul style="list-style-type: none"> • Cement based powder requiring addition of about 25 % water: StoMiral K (particle size 1.5 to 6.0 mm) StoMiral R (particle size 1.5 to 6.0 mm) StoMiral MP (fine structure) • Cement based powder requiring addition of 20 to 23 % water associated with a decorative paint: StoMiral Nivell F (fine structure) • Cement based powder requiring addition of about 30 % water associated with a decorative paint: Sto-Strukturputz K (particle size 2.0 and 3.0 mm) Sto-Strukturputz R (particle size 2.0 and 3.0 mm) 	<p>1.7 to 5.0</p> <p>1.7 to 4.5</p> <p>1.5 to 4.0</p> <p>3.0 to 4.5</p> <p>2.3 to 2.7</p> <p>2.4 to 2.7</p>	<p>regulated by particle size 1.5 to 3.5</p> <p>2.0 to 5.0</p> <p>regulated by particle size</p>
Decorative paint (optional)	<ul style="list-style-type: none"> • Ready to use paint with acrylic/siloxane binder: StoColor Silco StoColor Jumbosil StoColor Maxicryl StoColor Crylan Lotusan 	0.20 to 0.40 [l/m ²]	—
Ancillary material	Remains the responsibility of the manufacturer.		
* The instruction to the installer concerning the use of a key coat remains the responsibility of the manufacturer.			

2. Specification of the intended use in accordance with the applicable European assessment Document (hereinafter called EAD)

2.1 Intended use

This ETICS is intended to be used as external insulation to the walls of buildings made of masonry (bricks, blocks, stones ...) or concrete (cast on site or as prefabricated panels) with and without rendering. The characteristics of the walls shall be verified prior to use of the ETICS, especially regarding conditions for reaction to fire classification and for fixing of the ETICS either by bonding or mechanically. It shall be designed to give the wall to which it is applied satisfactory thermal insulation.

The ETICS is non load-bearing construction element. It does not contribute directly to the stability of the wall on which it is installed, but it can contribute to durability by providing enhanced protection from the effects of weathering.

The ETICS can be used on new or existing (retrofit) vertical walls.

The ETICS is not intended to ensure the air tightness of the building structure.

The choice of the method of fixing depends on the characteristics of the substrate, which could need preparation (see clause 7.2.1 of ETAG 004) and on the national instructions.

The verifications and assessment methods on which this European Technical Assessment (hereinafter called ETA) is based lead to the assumption of a working life of the ETICS "StoTherm Vario 7" of at least 25 years. The indications given on the working life cannot be interpreted as a guarantee given by the manufacturer, but are to be regarded only as a means for choosing the right products in relation to the assumed economically reasonable working life of the works

2.2 Manufacturing

The ETA is issued for the ETICS on the basis of agreed data/information, deposited with the DIBt, which identifies the ETICS that has been assessed and judged. Changes to the ETICS or the components or their production process, which could result in this deposited data/information being incorrect, should be notified to the DIBt before the changes are introduced. The DIBt will decide whether or not such changes affect the approval and consequently the validity of the CE marking on the basis of the approval and if so whether further assessment or alterations to the approval shall be necessary.

2.3 Design and installation

The installation instructions including special installation techniques and provisions for the qualification of the personnel are given in the manufacturer's technical documentation. Design, installation and execution of ETICS are to be in conformity with national documents. Such documents and the level of their implementation in Member States' legislation are different. Therefore, the assessment and declaration of performance are done taking into account general assumptions introduced in the chapters 7.1 and 7.2 of ETAG 004 used as EAD, which summarize how information introduced in the ETA and related documents is intended to be used in the construction process and gives advice to all parties interested when normative documents are missing.

2.4 Packing, transport and storage

The information on packaging, transport and storage is given in the manufacturer's technical documentation. It is the responsibility of the manufacturer to ensure that this information is made know to the concerned people.

2.5 Use, maintenance, repair

The finishing coat shall normally be maintained in order to fully preserve the ETICS performance. Maintenance includes at least:

- visual inspection of the ETICS
- the repairing of localised damaged areas due to accidents,
- the aspect maintenance with products adapted and compatible with the ETICS (possibly after washing or ad hoc preparation).

Only products which are compatible with the ETICS shall be used.

Necessary repairs should be performed as soon as the need has been identified.

The information on use, maintenance and repair is given in the manufacturer's technical documentation. It is the responsibility of the manufacturer to ensure that this information is made know to the concerned people.

3 Characteristics of products and methods of verification

3.0 General

The performances of the kit as described in this chapter are valid provided that the components of the kit comply with Annexes 1 to 4.

3.1 Mechanical resistance and stability (BWR 1)

not relevant

3.2 Safety in case of fire (BWR 2)
Reaction to fire (ETAG 004 - clause 5.1.2)

Configurations	Organic content	Flame retardant	Euroclass according to EN 13501-1
Base coat:	max. 3.2 %	no flame retardant	
EPS insulation product	In quantity ensuring Euroclass E according to EN 13501-1	In quantity ensuring Euroclass E according to EN 13501-1	
Profile	-	-	
Anchors	-	-	
Rendering system: Base coat with finishing coat and compatible key coat indicated hereafter			
Stolit K/R (particle size 3.5 to 6.0 mm) with key coat "Sto-Putzgrund"	max. 9.6 %	min.8.0 %	C – s2,d0
Stolit K/R (particle size 1.0 to 3.0 mm) with key coat "Sto-Putzgrund"			
Stolit Effect/MP with key coat "Sto-Putzgrund"			
StoMarlit K/R with key coat "Sto-Putzgrund"			
StoLotusan K/MP with key coat "Sto-Putzgrund"			
StoSilco K/R/MP with key coat "Sto-Putzgrund"			
Stolit QS K/R/MP with key coat "Sto-Putzgrund QS"			
StoSilco QS K/R/MP with key coat "Sto-Putzgrund QS"			
StoSil K/R/MP with key coat "StoPrep Miral"	max. 6.0 %	no flame retardant	B – s1,d0
StoMiral K/R/MP with key coat "StoPrep Miral"	max. 2.5 %		
StoMiral Nivell F with key coat "StoPrep Miral", associated with a decorative paint			
Sto-Strukturputz K/R with key coat "StoPrep Miral", associated with a decorative paint			

3.3 Hygiene, health and environment (BWR 3)

English translation prepared by DIBt

3.3.1 Water absorption (capillarity test) (ETAG 004 - clause 5.1.3.1)

Base coat:

- Water absorption after 1 h < 1.0 kg/m²
- Water absorption after 24 h < 0.5 kg/m²

• Rendering system:

		Water absorption after 24 h	
		< 0.5 kg/m ²	≥ 0.5 kg/m ²
Rendering systems: Base coat with finishing coat and paint indicated hereafter	Stolit K/R/Effect/MP	x	
	StoMarlit K/R	x	
	StoLotusan K/MP	x	
	StoSilco K/R/MP	x	
	Stolit QS K/R/MP	x	
	StoSilco QS K/R/MP	x	
	StoSil K/R/MP		x
	StoMiral K/R/MP	x	
	StoMiral Nivell F associated with a decorative paint	x	
	Sto-Strukturputz K/R associated with a decorative paint	x	

3.3.2 Hygrothermal behaviour (ETAG 004 - clause 5.1.3.2)

Pass (without defects)

Freeze/thaw behaviour

The ETICS with the finishing coats "StoSil" has been assessed as freeze/thaw resistant according to the simulated method.

3.3.3 Impact resistance (ETAG 004 – clause 5.1.3.3)

Standard mesh: "Sto-Glasfasergewebe" or "Sto-Glasfasergewebe F"

Rendering system: Base coat with finishing coat indicated hereafter	Standard mesh (total thickness about 5.5 mm)	Standard mesh (total thickness about 6 - 6.5 mm)	Standard mesh and Sto-Panzergerewebe
Stolit K/R/Effect/MP	Category II	Category II	Category II
StoMarlit K/R			
StoLotusan K/MP			
StoSilco K/R/MP			
Stolit QS K/R/MP			
StoSilco QS K/R/MP			
StoSil K/R/MP			
StoMiral K/R/MP			
StoMiral Nivell F, G			
Sto-Strukturputz K/R			

3.3.4 Water vapour permeability (ETAG004 – clause 5.1.3.4)

Rendering system: Base coat with finishing coat, compatible key coat and decorative paint indicated hereafter	Equivalent air thickness s_d
Stolit K/R/Effect/MP with key coat "Sto-Putzgrund"	≤ 1.0 m (Test result obtained with Stolit K2: 0.63 m)
StoMarlit K/R with key coat "Sto-Putzgrund"	≤ 1.0 m (Test result obtained with StoMarlit K2: 0.59 m)
StoLotusan K/MP with key coat "Sto-Putzgrund"	≤ 1.0 m (Test result obtained with StoLotusan K2: 0.38 m)
StoSilco K/R/MP with key coat "Sto-Prep Miral"	≤ 1.0 m (Test result obtained with StoSilco K2: 0.28 m)
StoSilco K/R/MP with key coat "Sto-Putzgrund"	≤ 1.0 m (Test result obtained with StoSilco K2: 0.53 m)
Stolit QS K/R/MP with key coat "Sto-Putzgrund QS"	≤ 1.0 m (Test result obtained with Stolit QS K2: 0.53 m)
Stolit QS K/R/MP with key coat "Sto Prep QS"	≤ 1.0 m (Test result obtained with Stolit QS K2: 0.59 m)
StoSilco QS K/R/MP with key coat "Sto Prep QS"	≤ 1.0 m (Test result obtained with StoSilco QS K2: 0.54 m)
StoSil K/R/MP with key coat "StoPrep Miral"	≤ 1.0 m (Test result obtained with StoSil K2: 0.28 m)
StoMiral K/R/MP with key coat "StoPrep Miral"	≤ 1.0 m (Test result obtained with StoMiral K2: 0.09 m)
StoMiral Nivell F with key coat "StoPrep Miral"	≤ 1.0 m (Test result obtained with d = 2 mm: 0.10mm)
StoMiral Nivell F with key coat "StoPrep Miral" and associated with a decorative paint	≤ 1.0 m (Test result obtained with d = 2 mm and a double coat of paint "StoColor Silco": 0.18 m) (Test result obtained with d = 2 mm and a double coat of paint "StoColor Jumbosil": 0.22 m) (Test result obtained with d = 2 mm and a double coat of paint "StoColor Lotusan": 0.13 m)
Sto-Strukturputz K/R with key coat "StoPrep Miral",	≤ 1.0 m (Test result obtained with Sto-Strukturputz K2: 0.09 m)
Sto-Strukturputz K/R with key coat "StoPrep Miral" and associated with a decorative paint	≤ 1.0 m (Test result obtained with d = 2 mm and a double coat of paint "StoColor Silco": 0.17 m) (Test result obtained with d = 2 mm and a double coat of paint "StoColor Jumbosil": 0.21 m) (Test result obtained with d = 2 mm and a double coat of paint "StoColor Lotusan": 0.12 m)

3.3.5 Release of dangerous substances (ETAG 004 - clause 5.1.3.5, EOTA TR 034)

Essential characteristic	Performance
Release of dangerous substances	no performance assessed

3.4 Safety and accessibility in use (BWR 4)

**3.4.1 Bond strength between base coat and insulation product (EPS)
(ETAG 004 - clause 5.1.4.1.1)**

Conditioning		
Initial state	After hygrothermal cycles on the rig	After freeze/thaw test
≥ 0.08 MPa	≥ 0.08 MPa	≥ 0.08 MPa

**3.4.2 Bond strength between adhesive and substrate resp. insulation product (EPS)
(ETAG 004 - clause 5.1.4.1.2 and 5.1.4.1.3)**

		Conditioning		
		Initial state	48 hrs. immersion in water and 2 hrs. drying	48 hrs. immersion in water and 7 days drying
StoLevell FT	Concrete	≥ 0.25 MPa	≥ 0.08 MPa	≥ 0.25 MPa
	EPS	≥ 0.08 MPa	≥ 0.03 MPa	≥ 0.08 MPa
StoLevell Uni	Concrete	≥ 0.25 MPa	≥ 0.08 MPa	≥ 0.25 MPa
	EPS	≥ 0.08 MPa	≥ 0.03 MPa	≥ 0.08 MPa
StoLevel Duo plus	Concrete	≥ 0.25 MPa	≥ 0.08 MPa	≥ 0.25 MPa
	EPS	≥ 0.08 MPa	≥ 0.03 MPa	≥ 0.08 MPa
StoColl IP	Concrete	≥ 0.25 MPa	≥ 0.08 MPa	≥ 0.25 MPa
	EPS	≥ 0.08 MPa	≥ 0.03 MPa	≥ 0.08 MPa
StoLevell Novo	Concrete	≥ 0.25 MPa	≥ 0.08 MPa	≥ 0.25 MPa
	EPS	≥ 0.08 MPa	≥ 0.03 MPa	≥ 0.08 MPa
StoLevell Alpha	Concrete	≥ 0.25 MPa	≥ 0.08 MPa	≥ 0.25 MPa
	EPS	≥ 0.08 MPa	≥ 0.03 MPa	≥ 0.08 MPa
Sto-Baukleber	Concrete	≥ 0.25 MPa	≥ 0.08 MPa	≥ 0.25 MPa
	EPS	≥ 0.08 MPa	≥ 0.03 MPa	≥ 0.08 MPa
Sto-Dispersions- kleber	Concrete	≥ 0.25 MPa	≥ 0.08 MPa	≥ 0.25 MPa
	EPS	≥ 0.08 MPa	≥ 0.03 MPa	≥ 0.08 MPa

Bonded surface:

For bonded ETICS the calculated minimal bonded surface area, according to ETAG 004, clause 6.1.4.1.3 is 40 %.

3.4.3 Fixing strength (displacement test) (ETAG 004 - clause 5.1.4.2)

Test not required therefore no limitation of ETICS length required.

English translation prepared by DIBt

3.4.4 Bond strength after ageing (ETAG 004 – clause 5.1.7.1)

Rendering system: Base coat with finishing coat indicated hereafter	Stolit K/R/Effect/MP	≥ 0.08 MPa
	StoMarlit K/R	
	StoLotusan K/MP	
	StoSilco K/R/MP	
	Stolit QS K/R/MP	
	StoSilco QS K/R/MP	
	StoSil K/R/MP	
	StoMiral K/R/MP	
	StoMiral Nivell F, G	
	Sto-Strukturputz K/R	

3.4.5 Wind load resistance (ETAG 004 - clause 5.1.4.3)

The following failure loads only apply to the listed combination and the characteristics of the insulation product given in annex 1.

3.4.5.1 Safety in use of mechanically fixed ETICS using profiles

Characteristics of the EPS (standard EPS)	Dimensions	500 mm x 500 mm
	Thickness	≥ 60 mm
	Tensile strength perpendicular to the faces	≥ 150 kPa
	Shear modulus	≥ 1.0 N/mm ²
Failure loads [N / panel] (Static Foam Block Test)	Horizontal profiles fixed every 30 cm and 49.4 cm long vertical connection profiles	Minimal: 950 Average: 1010

3.4.5.2 Safety in use of mechanically fixed ETICS using anchors

Apply to all anchors listed in the clause 1.2 mounted on the insulation panels surface				
Characteristics of the EPS (standard EPS)	Thickness		≥ 60 mm	
	Tensile strength perpendicular to the faces		≥ 100 kPa	
	Shear modulus		≥ 1.0 N/mm ²	
Plate diameter of anchor			Ø 60 mm	Ø 90 mm
Failure loads [N]	Anchors not placed at the panel joints (Static Foam Block Test)	R_{panel}	Minimal: 510 Average: 520	Minimal: 720 Average: 730
	Anchors placed at the panel joints (Pull-through test)	R_{joint}	Minimal : 400 Average: 430	Minimal: 430 Average: 470

Apply to all anchors listed in the clause 1.2 mounted on the insulation panels surface			
Characteristics of the EPS (elastified EPS)	Thickness		≥ 60 mm
	Tensile strength perpendicular to the faces		≥ 80 kPa
	Shear modulus		≥ 0.3 N/mm ²
Plate diameter of anchor			∅ 60 mm
Failure loads [N]	Anchors not placed at the panel joints (Static Foam Block Test)	R _{panel}	Minimal: 350 Average: 360
	Anchors placed at the panel joints (Pull-through test)	R _{joint}	Minimal: 300 Average: 310

The failure loads specified above for a plate diameter of anchor of 60 mm apply to the following anchors with deep mounting but only on the following conditions of installation:

Anchor	Thickness of the EPS [d]	Conditions of installation*
ejotherm STR U, ejotherm STR U 2G (ETA-04/0023)	100 mm > d ≥ 80 mm (for standard and elastified EPS)	– Maximum installation depth of the anchor plate: 15 mm (△ thickness of insulation cover) – Maximum depth of die: 5 mm
	≥ 100 mm (for standard and elastified EPS)	– Maximum installation depth of the anchor plate: 15 mm (△ thickness of insulation cover) – Maximum depth of die: 20 mm
TERMOZ 8 SV (ETA-06/0180)	≥ 80 mm (for standard EPS only)	– Maximum installation depth of the anchor plate: 15 mm (△ thickness of insulation cover)

* according to the appropriate ETA of anchor

3.4.6 Render strip tensile test (ETAG 004 – clause 5.5.4.1)

The average value of crack width of the base coat reinforced with the different glass fibre meshes measured at a render strain value of 1 % is:

StoLevell Uni with the mesh indicated hereafter	Average value of crack width w _{m(1%)}
Sto-Glasfasergewebe	0.16 mm
Sto-Glasfasergewebe F	0.06 mm

3.5 Protection against noise (BWR 5)

For the protection against noise no performance was assessed for this product.

3.6 Energy economy and heat retention (BWR 6)

3.6.1 Thermal resistance

The nominal value of the additional thermal resistance R provided by the ETICS to the substrate wall is calculated in accordance with EN ISO 6946:2007 from the nominal value of the insulation product's thermal resistance R_D given accompanied to the CE marking and from the thermal resistance of the rendering system R_{render} which is about 0.02 (m² · K)/W.

$$R = R_D + R_{render}$$

English translation prepared by DIBt

The thermal bridges caused by anchors profiles increases the thermal transmittance U. This influence had to take into account according to EN ISO 6946:2007:

$$U_c = U + \chi_p \cdot n$$

- Where:
- U_c : corrected thermal transmittance [$W/(m^2 \cdot K)$]
 - n : number of anchors per m^2
 - χ_p : local influence of thermal bridge caused by an anchor. The values listed below can be taken into account if not specified in the anchor's ETA:
 - $\chi_p = 0.004 \text{ W/K}$ for anchors with a galvanized steel screw with the head covered by a plastic material
 - $\chi_p = 0.002 \text{ W/K}$ for anchors with a stainless steel screw covered by plastic anchors and for anchors with an air gap at the head of the screw

The thermal bridges caused by profiles are negligible.

4 Assessment and verification of constancy of performance (hereinafter AVCP) system applied, with reference to its legal base

According to the European Commission decision 97/556/EC amended by the European Commission decision 2001/596/EC, the assessment and verification of constancy of performance system (AVCP) applies suitable following table (see Annex V to Regulation (EU) No 305/2011).

Product	Intended use	Levels or classes (Reaction to fire)	Systems
"Sto Therm Vario 7"	in external wall subject to fire regulations	A1 ⁽¹⁾ , A2 ⁽¹⁾ , B ⁽¹⁾ , C ⁽¹⁾	1
		A1 ⁽²⁾ , A2 ⁽²⁾ , B ⁽²⁾ , C ⁽²⁾ , D, E, (A1 to E) ⁽³⁾ , F	2+
	in external wall not subject to fire regulations	any	2+
⁽¹⁾ Products/materials for which a clearly identifiable stage in the production process results in an improvement of the reaction to fire classification (e.g. an addition of fire retardants or a limiting of organic material) ⁽²⁾ Products/materials not covered by footnote (1) ⁽³⁾ Products/materials that do not require to be tested for reaction to fire (e.g. products/materials of Classes A1 according to Commission Decision 96/603/EC)			

5 Technical details necessary for the implementation of the AVCP system, as provided for in the applicable European Assessment Document (EAD)

Technical details necessary for the implementation of the AVCP system are laid down in the control plan deposited at Deutsches Institut für Bautechnik.

Issued in Berlin 21 December 2017 by Deutsches Institut für Bautechnik

Dirk Brandenburger
Head of Department

beglaubigt:
Windhorst

European Technical Assessment
ETA-12/0561
English translation prepared by DIBt

Page 16 of 20 | 16 February 2018

Annexes:

- Annex 1: Thermal insulation product characteristic
- Annex 2: Anchors
- Annex 3: Profiles
- Annex 4: Reinforcement

Annex 1: Thermal insulation product characteristic

Factory-prefabricated, uncoated panels made of expanded polystyrene (EPS) to EN 13163:2015 shall be used, having the description and characteristics defined in the Table below.

Description and characteristics	For bonded ETICS	For mechanically fixed ETICS	
		with anchors and supplementary adhesive	with profiles and supplementary adhesive ****
Reaction to fire; EN 13501-1:2007	Class E*		
Thermal resistance [(m ² ·K)/W]	Defined in the CE marking in reference to EN 13163:2015		
Tolerances			
Length; EN 822:2013	± 0.6 % or ± 3 mm whichever gives the greatest numerical tolerance (class L3)		
Width [mm]; EN 822: 2013	± 2 (class W2)		
Thickness [mm]; EN 823:2013	± 1 (class T1)		
Squareness [mm/m]; EN 824: 2013	± 2 (class S2)		
Flatness [mm/m]; EN 825:2013	5 (class P5)		
Dimensional stability under			
- laboratory conditions [%]; EN 1603:2013	± 0.2 (class DS(N)2)		
- specified temperature and humidity conditions [%]; EN 1604:2013	2 (level DS(70,-)2 or level DS(70,-)1)		
Water absorption (long term partial immersion) [kg/m ²]; EN 12087:2013	W _{ip} ≤ 0.5		
Water vapour diffusion resistance factor; EN 12086:2013	μ = 20 – 78		
Tensile strength perpendicular to the faces in dry conditions** [kPa]; EN 1607:2013			
- standard EPS	σ _{mt} ≥ 80	σ _{mt} ≥ 100	σ _{mt} ≥ 150
- elastified EPS***	σ _{mt} ≥ 80	σ _{mt} ≥ 80	not used
Bending strength** [kPa]; EN 12089:2013	σ _b ≥ 50		
Apparent density [kg/m ³]; EN 1602: 2013	ρ _a ≤ 30		
Shear strength** [kPa]; EN 12090: 2013	20 ≤ f _{tk} ≤ 170		
Shear modulus [MPa]; EN 12090: 2013			
- standard EPS	1.0 ≤ G _m ≤ 3.8		
- elastified EPS***	0.3 ≤ G _m ≤ 1.0	0.3 ≤ G _m ≤ 1.0	not used
Testing of characteristics see EN 13163:2015.			
* See the conditions of clause 3.2 for the EPS.			
** Minimal value of all single values			
*** Elastified EPS is made from standard EPS by short time high load pressing to reduce the dynamic stiffness. The protection against noise of the entire wall is improved by the use of elastified EPS related to an ETICS with standard EPS.			
**** Thermal insulation materials for mechanically fixed ETICS with profiles must circumferentially at the edges, 24 mm from the inner surface, get an approx. 3 mm wide and 13 to 18 mm deep groove cut-in at the factory.			

Annex 2: Anchors

All anchors with ETA according to EAD 330196-00-0604¹ with characteristics having the description below shall be used in the mechanically fixed ETICS:

- plate diameter of anchor ≥ 60 mm resp. ≥ 90 mm
- plate stiffness ≥ 0.3 kN/mm
- load resistance of the anchor plate ≥ 1.0 kN

These characteristics and the characteristic tension resistance of the anchors shall be taken from the corresponding ETA.

These characteristics and the characteristic tension resistance of the anchors shall be taken from the corresponding ETA.

The anchors listed in the Table in clause 1.2 with reference to the respective ETA shall be used in the mechanically fixed ETICS with profiles for fixing the horizontal profiles.

Trade name	ETA-number
WS 8 L	ETA-02/0019
WS 8 N	ETA-03/0019
IsoFux ND-8Z	ETA-04/0032
SDF-K plus	ETA-04/0064
ejothem NK U	ETA-05/0009

Annex 3: Profiles

Polyvinyl chloride (PVC) profiles, PVC-U, EGL, 082-05-T33 to EN ISO 1163-1: are to be used in the mechanically fixed ETICS with profiles.

The Pull-through resistance of fixings from profiles is ≥ 500 N.

Horizontal profile – "Sto-Halteleiste PVC" (dimensions in millimetres)

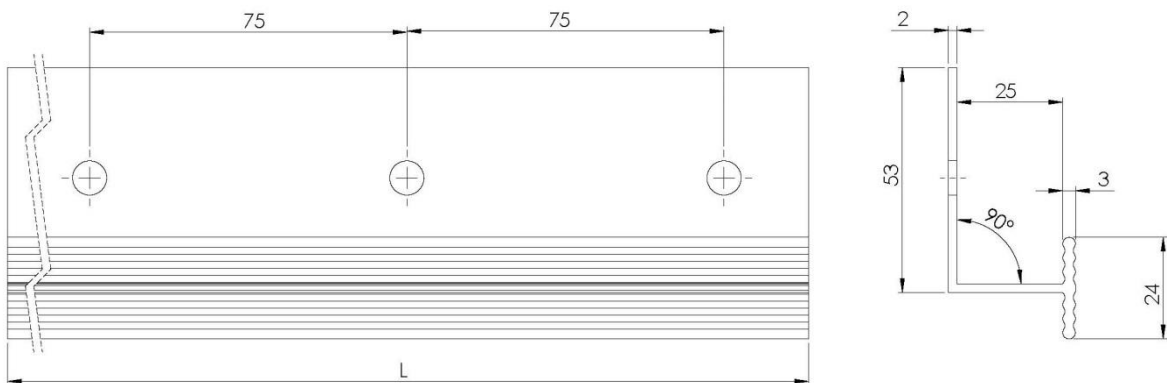

Vertical connection profile "Sto-Halteleiste PVC" (dimensions in millimetres)

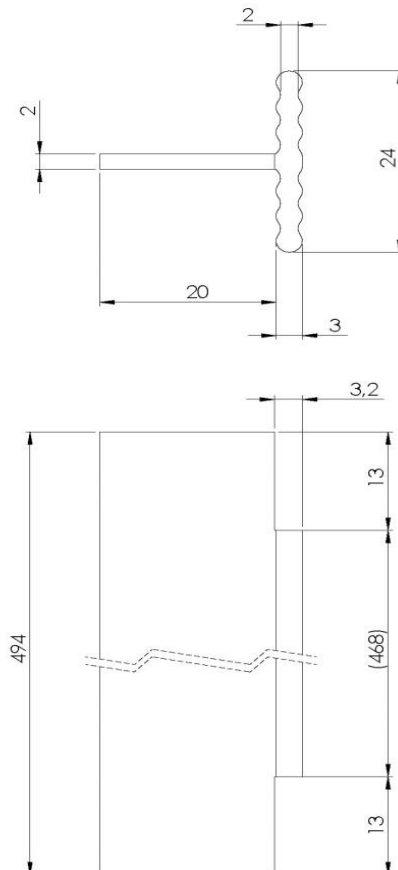

Annex 4: Reinforcement (glass fibre mesh)

Characteristics (alkali resistance): Pass

	Description	Residual strength after ageing [N/mm]	Relative residual strength after ageing, of the strength in the as-delivered state [%]
"Sto-Glasfasergewebe"	Alkali- and slide-resistant glass fibre mesh with mass per unit area of about 165 g/m ² and mesh size of about 6.0 mm x 6.0 mm	≥ 20	≥ 50
"Sto-Glasfasergewebe F"	Alkali- and slide-resistant glass fibre mesh with mass per unit area of about 165 g/m ² and mesh size of about 4.0 mm x 4.0 mm	≥ 20	≥ 50
"Sto-Panzergewebe"	(reinforced mesh implemented in addition to the meshes described above to improve the impact resistance) Alkali- and slide-resistant glass fibre mesh with mass per unit area of about 450 g/m ² and mesh size of about 7.5 mm x 7.5 mm	no performance assessed	no performance assessed