

Approval body for construction products
and types of construction

Bautechnisches Prüfamt

An institution established by the Federal and
Laender Governments



European Technical Assessment

ETA-12/0583
of 12 January 2018

English translation prepared by DIBt - Original version in German language

General Part

Technical Assessment Body issuing the
European Technical Assessment:

Deutsches Institut für Bautechnik

Trade name of the construction product

HI-MACS-Undercut Anchor for HI-MACS facade panels
type: S728 CE MED Alpine White

Product family
to which the construction product belongs

Fastener for rear fixing for facade panels made of natural
acrylic stone

Manufacturer

LG Hausys Europe GmbH
Lyoner Straße 15
60528 Frankfurt/Main
DEUTSCHLAND

Manufacturing plant

Herstellwerk 1

This European Technical Assessment
contains

14 pages including 3 annexes which form an integral part
of this assessment

This European Technical Assessment is
issued in accordance with Regulation (EU)
No 305/2011, on the basis of

EAD 330030-00-0601

**European Technical Assessment
ETA-12/0583**

Page 2 of 14 | 12 January 2018

English translation prepared by DIBt

The European Technical Assessment is issued by the Technical Assessment Body in its official language. Translations of this European Technical Assessment in other languages shall fully correspond to the original issued document and shall be identified as such.

Communication of this European Technical Assessment, including transmission by electronic means, shall be in full. However, partial reproduction may only be made with the written consent of the issuing Technical Assessment Body. Any partial reproduction shall be identified as such.

This European Technical Assessment may be withdrawn by the issuing Technical Assessment Body, in particular pursuant to information by the Commission in accordance with Article 25(3) of Regulation (EU) No 305/2011.

Specific Part

1 Technical description of the product

The HI-MACS-Undercut Anchor for HI-MACS façade panels type: S728 CE MED Alpine White is a fastener made of stainless steel, consisting of a crosswise slotted anchor sleeve with an M6 internal thread, at the upper edge of which a hexagon is formed to it and a respective hexagon bolt with an integrated tooth lock washer. Alternatively, instead of the hexagon bolt with an integrated tooth lock washer, a threaded pin or threaded rod is used. The fastener is put into an undercut drill hole and by driving-in the screw it is placed form-fitted and deformation-controlled. The product description is given in Annex A. The material values, dimensions and tolerances of the components of the fastener not indicated in the annexes shall correspond to the values laid down in the technical documentation¹.

2 Specification of the intended use in accordance with the applicable European Assessment Document

The performances given in Section 3 are only valid if the fastener is used in compliance with the specifications and conditions given in Annex B.

The verifications and assessment methods on which this European Technical Assessment is based lead to the assumption of a working life of the fasteners of at least 50 years. The indications given on the working life cannot be interpreted as a guarantee given by the producer, but are to be regarded only as a means for choosing the right products in relation to the expected economically reasonable working life of the works.

3 Performance of the product and references to the methods used for its assessment

3.1 Mechanical resistance and stability (BWR 1)

Essential characteristic	Performance
Characteristic resistance for tension and shear loads	See Annex C 1
Fastener distances	See Annex C 1
Durability	Corrosion Resistance Class (CRC) III according to EN 1993-1-4:2015

3.2 Safety in case of fire (BWR 2)

Essential characteristic	Performance
Reaction to fire	Class A1
Resistance to fire	No performance assessed

4 Assessment and verification of constancy of performance (AVCP) system applied, with reference to its legal base

In accordance with EAD No. 330030-00-0601 the applicable European legal act is: [97/161/EG].
The system to be applied is: 2+

¹ The technical documentation comprises all information of the holder of this ETA necessary for the production, installation and maintenance of the fastener; these are in particular design drawings. The part to be treated confidentially is deposited with Deutsches Institut für Bautechnik and, as far as this is relevant to the tasks of the approved bodies involved in the procedure of attestation of conformity, shall be handed over to the approved body.

5 Technical details necessary for the implementation of the AVCP system, as provided for in the applicable European Assessment Document

Technical details necessary for the implementation of the AVCP system are laid down in the control plan deposited with Deutsches Institut für Bautechnik.

Issued in Berlin on 12 January 2018 by Deutsches Institut für Bautechnik

BD Dipl.-Ing. Andreas Kummerow
Head of Department

beglaubigt:
Aksünger

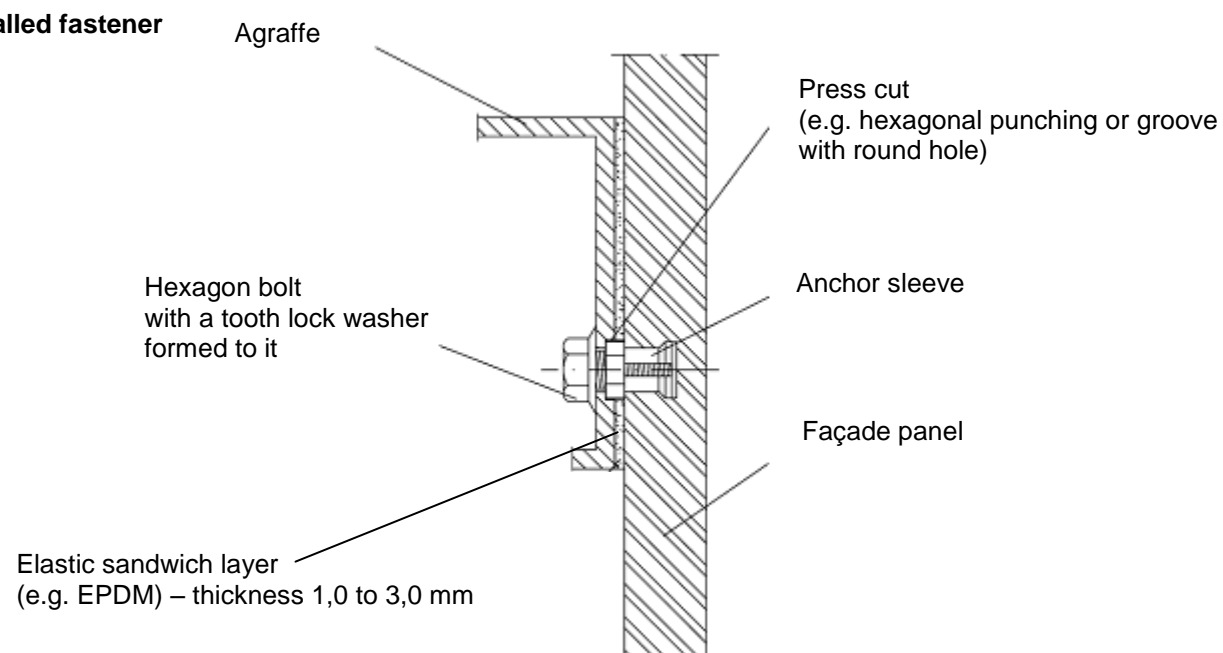
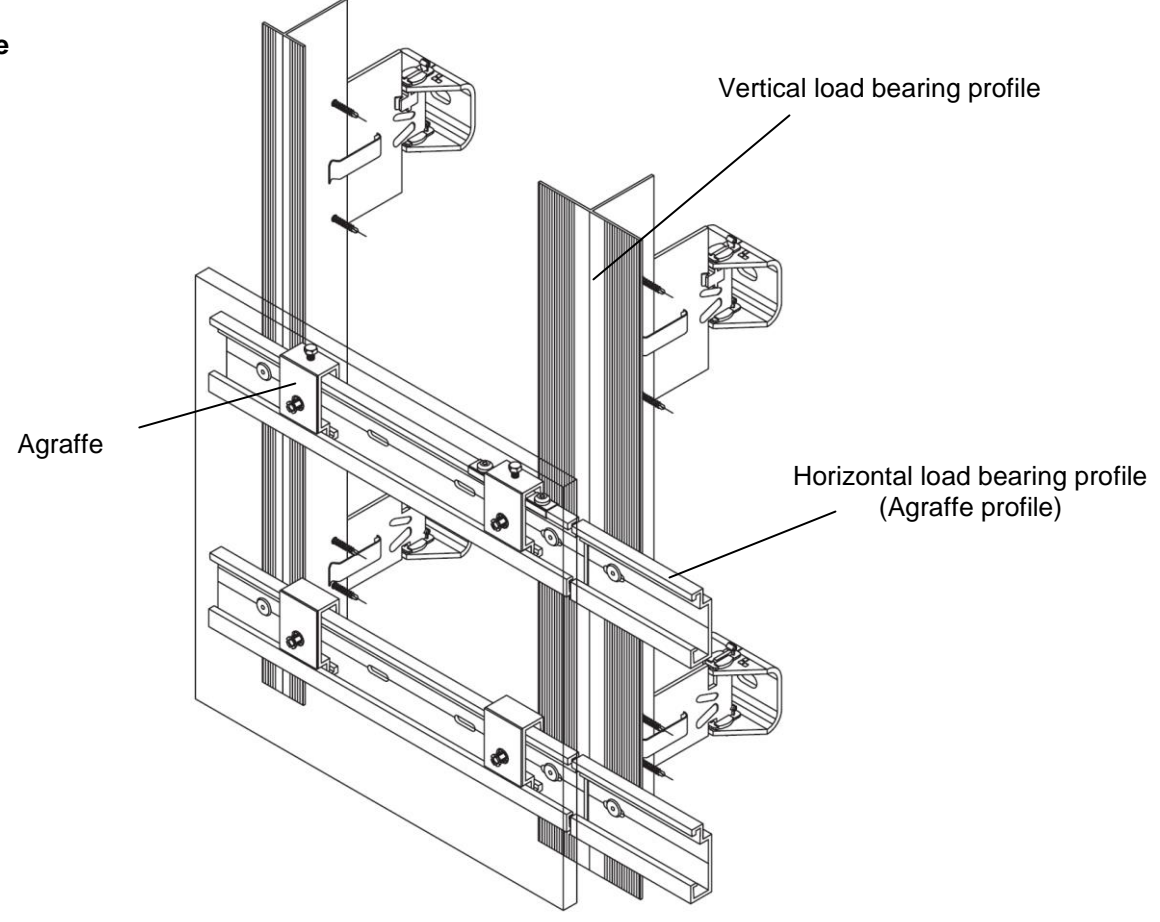
<p>Installed fastener</p>  <p>Agraffe</p> <p>Press cut (e.g. hexagonal punching or groove with round hole)</p> <p>Hexagon bolt with a tooth lock washer formed to it</p> <p>Anchor sleeve</p> <p>Façade panel</p> <p>Elastic sandwich layer (e.g. EPDM) – thickness 1,0 to 3,0 mm</p>	
<p>Fixing example</p>  <p>Vertical load bearing profile</p> <p>Agraffe</p> <p>Horizontal load bearing profile (Agraffe profile)</p>	
<p>HI-MACS-Undercut Anchor for HI-MACS facade panels type: S728 CE MED Alpine White</p> <p>Product description Installed fastener and fixing example</p>	<p>Annex A 1</p>

Fastener (dimension in mm)

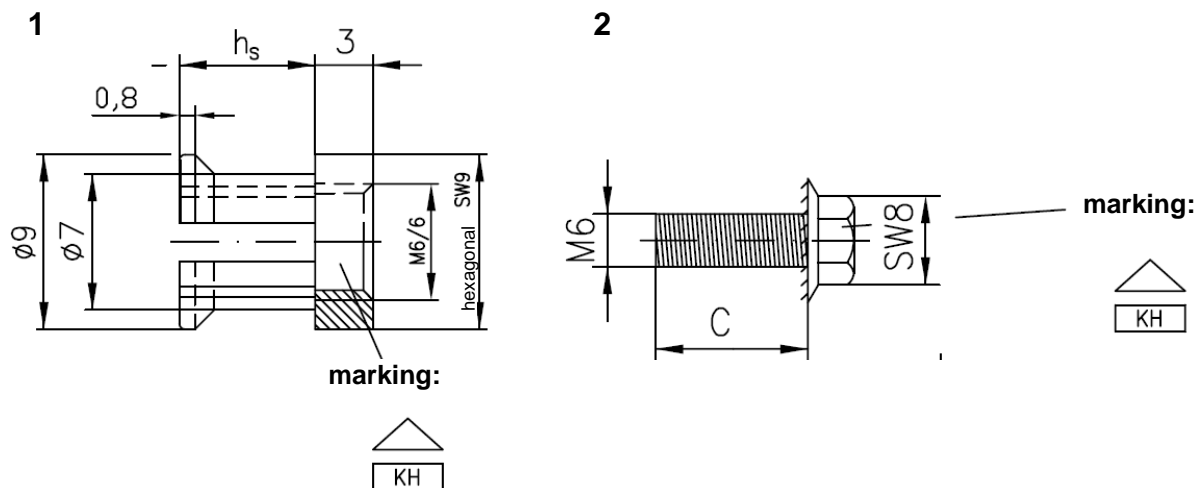

c: The screw length must be adjusted to the respective design

Table A1: Dimensions and Materials

Fastener type		HI-MACS-Undercut Anchor
embedment depth	$h_s =$ [mm]	8,5
screw length	$c =$ [mm]	$h_s + 3\text{mm} + t_{\text{fix}}$
installation torque moment	T_{inst} [Nm]	$2,5 \leq T_{\text{inst}} \leq 4,0$
Materials		
1	anchor sleeve	Stainless steel EN 10088:2014
2	hexagon screw with tooth lock washer	Stainless steel according to EN 10088:2014

HI-MACS-Undercut Anchor for HI-MACS facade panels type: S728 CE MED Alpine White

Product description
Dimensions and Materials

Annex A 2

Specifications of intended use

Anchorage subject to:

- Static and quasi-static loads.

Use conditions (Environmental conditions):

- According to EN 1993-1-4:2015 according to the Corrosion Resistance Class of the fastener (see section 3.1)

Base materials:

- The bending strength of HI-MACS façade panel type: S728 CE MED Alpine White with homogeneous and non-porous surface shall be determined according to EN ISO 178:2013-09.
- The characteristic values of the façade plates correspond to Table B1.

Table B1: characteristic values of the façade panels – geometrical and physical properties

Nominal thickness of façade panel	$h_{nom} =$	[mm]	12
Mean value of modulus of elasticity	$E_{mean} =$	[N/mm ²]	8500
thermal coefficient	$\alpha_T =$	[1/K]	30×10^6
Specific weight	$\gamma =$	[kN/m ³]	17,5
bending resistance	$\sigma_{5\%}^{1)} \geq$	[N/mm ²]	63,0

¹⁾ 5%-Quantil by a confidence level of 75 % and unknown standard deviation

Design:

General:

- Each façade panel is fixed with at least four fasteners in a rectangular arrangement via single agraffes on the substructure (for small panels or small fitted pieces, differential or fill- in pieces the number and position of the fasteners shall be chosen constructively).
- Edge distance and spacing shall be observed. For small fitted pieces, differential and fill-in pieces the edge distance and spacing shall be chosen.
- The substructure is constructed such that the façade panels are fixed technically strain-free via skids (loose bearings) and one fixed point (fixed bearing) - the fixed point may be placed at the panel edge or in the panel field.
- Two fixing points of the façade panel are designed such that they are able to carry the dead load of the façade panel.
- Constraint loads shall be into account for design, if constraint loads exists.
- When using agraffes on horizontal load-bearing profiles the fixing points of a façade panel situated horizontally at the same height are fastened in each case to the same load-bearing profile.
- Verifiable calculation notes and drawings shall be prepared taking account of the loads to be anchored, the nature and strength of the base materials and the dimensions of the anchorage members as well as of the relevant tolerances. The position of the fastener is indicated on the design drawings.

HI-MACS-Undercut Anchor for HI-MACS facade panels type: S728 CE MED Alpine White

Intended use
Specifications

Annex B 1

Verification ultimate limit state:

Anchorage are designed under the responsibility of an engineer experienced in anchorages and facade construction.

$$\frac{N_{Ed}}{N_{Rd}} \leq 1$$

$$\frac{V_{Ed}}{V_{Rd}} \leq 1$$

$$\frac{N_{Ed}}{N_{Rd}} + \frac{V_{Ed}}{V_{Rd}} \leq 1,0$$

N_{Ed} : Design value of the tensile force

$$N_{Ed} = N_{Ek,w} \cdot \gamma_F + N_{Ek,v} \cdot \gamma_F$$

$N_{Ek,w}$: characteristic value of the tensile force of wind load

γ_F : partial safety factor according to EN 1990:2010

$N_{Ek,v}$: For flush fixed fasteners and for installation of horizontal load-bearing profiles permanent loads due to torsion of the profile shall be considered in addition to actions from dead load and wind in direction of the fastener axes. The verification can be omitted, if there is no horizontal distance between fastener and vertical load-bearing profile ($N_{Ek,v} = 0$).

$$N_{Ek,v} = V_{Ek} \cdot e/z$$

V_{Ek} = characteristic value of the shear force due to dead load of the façade panel
e and z [mm] see picture

M shear centre

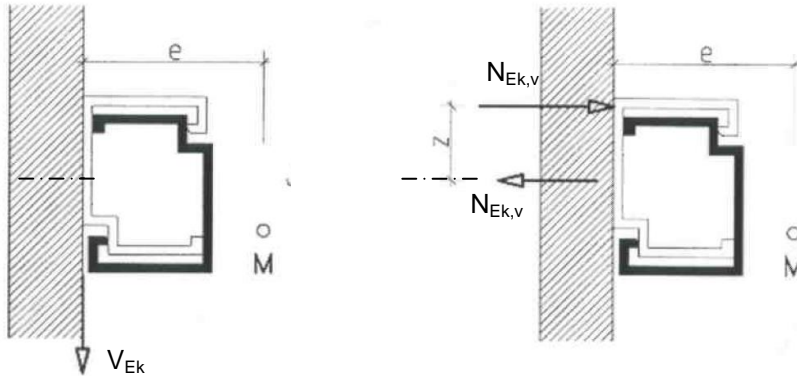

N_{Rd} : design value of the tensile load-bearing capacity

$$N_{Rd} = N_{Rk} / \gamma_M$$

N_{Rk} : characteristic value of the tensile load-bearing capacity according to Table C1
 $\gamma_M = 2,0$; recommended partial safety factor, in absence of national regulations

V_{Ed} : design value of the shear force

$$V_{Ed} = V_{Ek} \cdot \gamma_F$$

V_{Ek} : characteristic value of the shear force

γ_F : partial safety factor according to EN 1990:2010

V_{Rd} : design value of the shear load-bearing capacity

$$V_{Rd} = V_{Rk} / \gamma_M$$

V_{Rk} : characteristic value of the shear load-bearing capacity according to Tabelle C1
 $\gamma_M = 2,0$; recommended partial safety factor, in absence of national regulations

HI-MACS-Undercut Anchor for HI-MACS facade panels type: S728 CE MED Alpine White

Intended use
Specifications

Annex B 2

Installation:

- The drillings are done at the factory or on site under workshop conditions; when making the drillings on site the execution is supervised by the responsible project supervisor or a skilled representative of the project supervisor.
- Bore holes are drilled with a special drill bit according to Annex B 4 and a special drilling device.
- The drilling dust is removed from the drill hole
- In case of aborted hole: new drilling at a minimum distance away of twice the depth of the aborted hole.
- the geometry of the drill hole is checked on 1 % of all drillings. The following dimensions shall be checked and documented according to manufacturer's information and testing instructions by means of a measuring device according to Annex B 4:
 - Volume of the undercut drill hole.
 - Depth position of the undercut; the distance between the lower edge of the measuring device and the façade panel is between 0,0 and 0,3 mm (see Annex B 4).

If the tolerances are exceeded, the geometry of the drill hole shall be checked on 25% of the drillings performed. No further drill hole may exceed the tolerances otherwise all the drill holes shall be controlled. Drilling holes falling below or exceeding the tolerances shall be rejected.

Note: Checking the geometry of the drill hole on 1 % of all drillings means that on one of the 25 panels (this corresponds to 100 drillings in façade panels with four fasteners) one drilling shall be checked. If the tolerances given in Annex A 2, Table A1 are exceeded the extent of the control shall be increase to 25 % of the drillings, i.e. one drilling each shall be checked on all the 25 panels.

- During transport and storage on site the façade panels are protected from damages; the façade panels are not be hung up jerkily (if need be lifters shall be used for hanging up the façade panels); façade panels and reveal panels respectively with incipient cracks are not be installed.
- The façade are installed by skilled specialists and the laying instructions of the manufacturer shall be paid attention to.
- The façade panels are arranged in a "reclined" or "upright" position, they also may be fixed at façade soffits.

electronic copy of the eta by dibt: eta-12/0583

HI-MACS-Undercut Anchor for HI-MACS facade panels type: S728 CE MED Alpine White	Annex B 3
Intended use Specifications	

Geometry of the drill hole

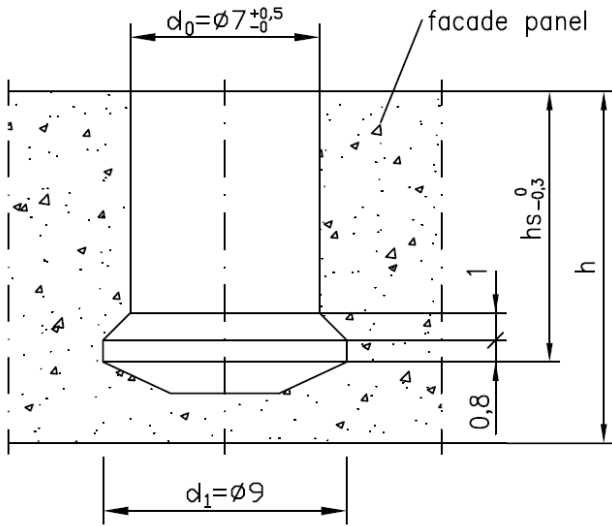

Geometry of the KEIL facade drill

for KEIL facade drill bit 7/9

HM 12/0,8

HM CNC 13/0,8

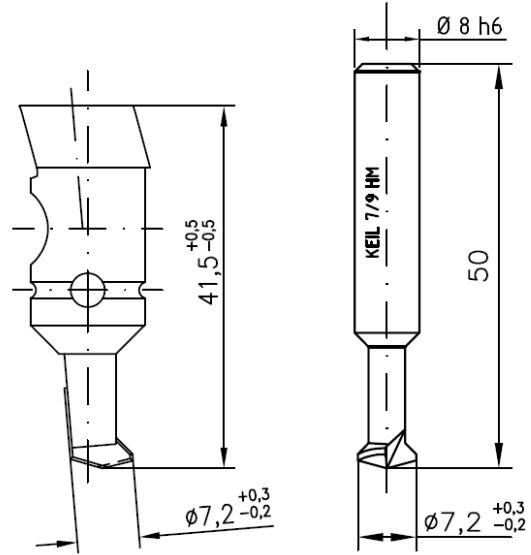

KEIL measuring device

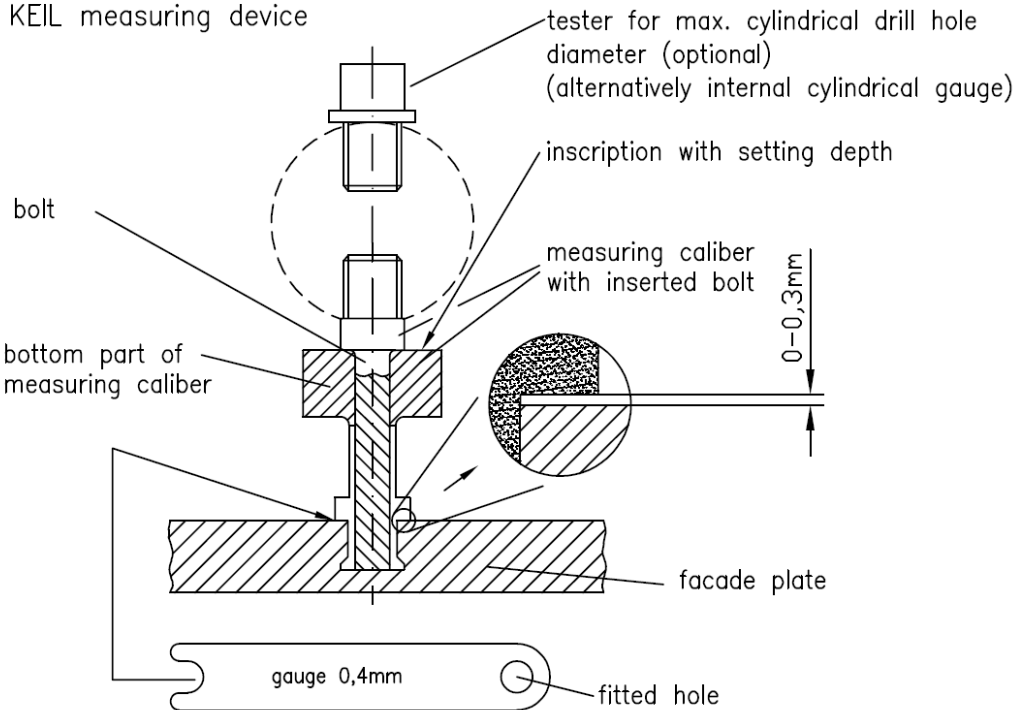

electronic copy of the eta by dibt: eta-12/0583

HI-MACS-Undercut Anchor for HI-MACS facade panels type: S728 CE MED Alpine White

Intended use
Bore hole geometry, drill hole geometry and measurement device

Annex B 4

Definition of edge distance and spacing

single fixing

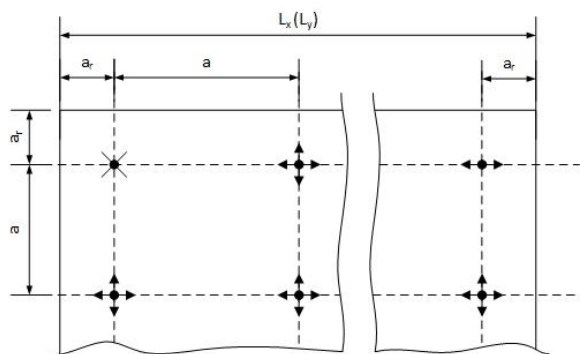

fixing with double agraffes

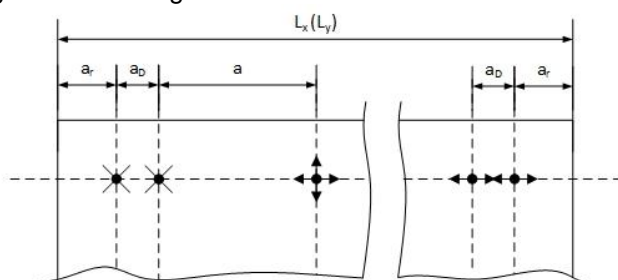

Legend

a = spacing – distance between fasteners

a_D = spacing – distance between fasteners of double agraffes

a_r = edge distance – distance between fastener and panel edge

L_x = length of the facade panel in horizontal direction

L_y = length of the facade panel in vertical direction



= fixed point (locating bearing) between facade panel and substructure



= horizontal sliding point (floating bearing) between panel and substructure



= horizontal and vertical sliding point between facade panel and substructure

Example for fixed point and loose bearing

fixed bearing (fixed point)

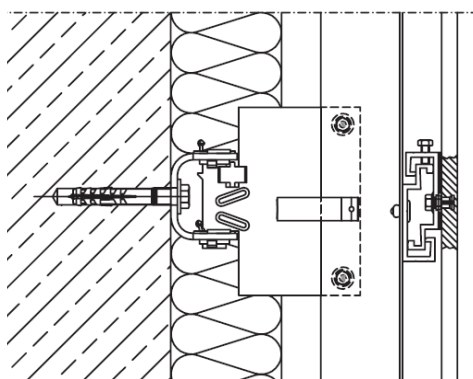

loose bearing (skid)

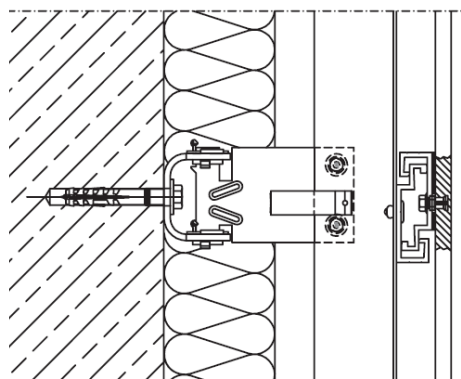

HI-MACS-Undercut Anchor for HI-MACS facade panels type: S728 CE MED Alpine White

Intended use

Definition of edge distance and spacing

Annex B 5

Installation instructions

1. Drilling the undercut hole

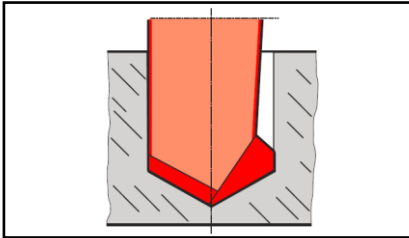

a) Cylindrical drilling

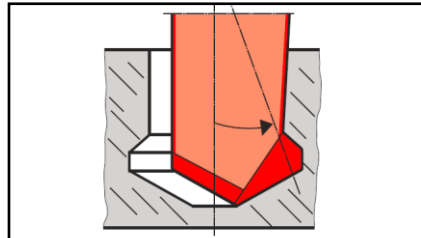

b) Undercutting and cleaning

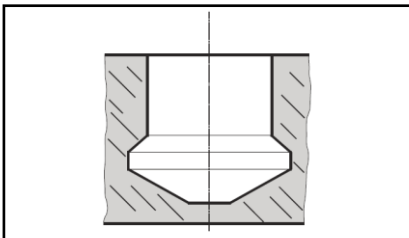

c) Finished undercut hole

2. Checking the undercut hole

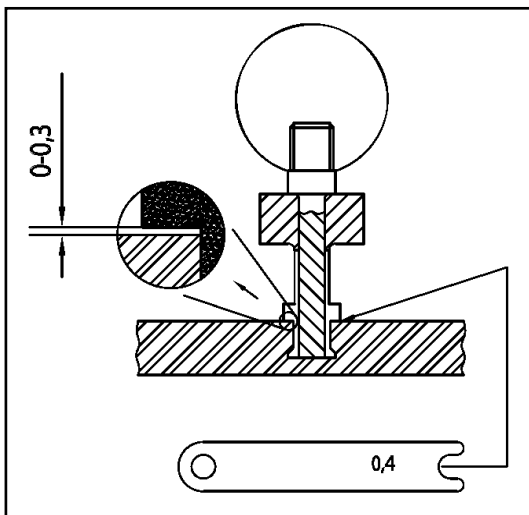

With KEIL depth control guide

HI-MACS-Undercut Anchor for HI-MACS facade panels type: S728 CE MED Alpine White

Intended use
Installation instructions

Annex B 6

3. Installation of fastener (sleeve and screw)

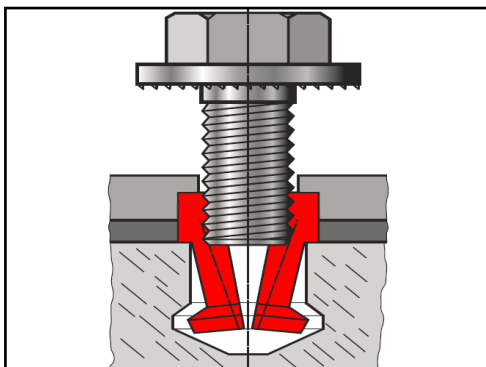

a) Insert the sleeve in the undercut hole and drill the screw in the sleeve

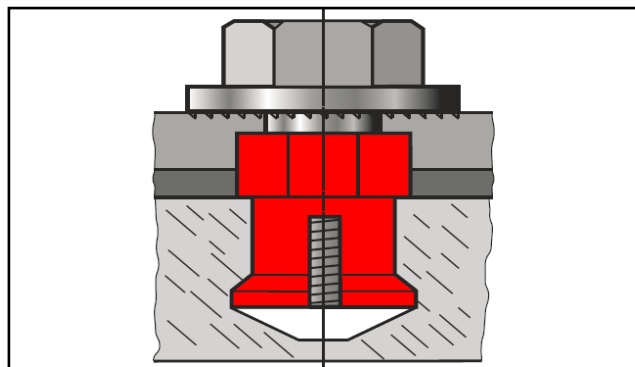

b) Installed undercut anchor

HI-MACS-Undercut Anchor for HI-MACS facade panels type: S728 CE MED Alpine White

Intended use
Installation instructions

Annex B 7

Characteristic values of the fastener in HI-MACS façade panel type: S728 CE MED Alpine White

Table C1:

embedment depth	$h_s =$	[mm]	8,5
characteristic resistance to	tension load	$N_{Rk} =$	1,8
	shear load	$V_{Rk} =$	4,1
edge distance	$a_r \geq$	[mm]	100
spacing	$a \geq$	[mm]	100

HI-MACS-Undercut Anchor for HI-MACS facade panels type: S728 CE MED Alpine White

Performance

Characteristic values of the fastener in HI-MACS façade panel type: S728 CE MED Alpine White

Annex C 1