

Approval body for construction products
and types of construction

Bautechnisches Prüfamt

An institution established by the Federal and
Laender Governments



European Technical Assessment

ETA-13/0197
of 14 May 2018

English translation prepared by DIBt - Original version in German language

General Part

Technical Assessment Body issuing the
European Technical Assessment:

Deutsches Institut für Bautechnik

Trade name of the construction product

Cut string stair system Treppenmeister

Product family
to which the construction product belongs

Prefabricated stair with steps and cut strings made of
solid wood for use as an indoor stair in buildings

Manufacturer

Treppenmeister GmbH
Emminger Straße 38
71131 Jettingen
DEUTSCHLAND

Manufacturing plant

Treppenmeister plant 1-85

This European Technical Assessment
contains

13 pages including 3 annexes which form an integral part
of this assessment

This European Technical Assessment is
issued in accordance with Regulation (EU)
No 305/2011, on the basis of

EAD 340006-00-0506

The European Technical Assessment is issued by the Technical Assessment Body in its official language. Translations of this European Technical Assessment in other languages shall fully correspond to the original issued document and shall be identified as such.

Communication of this European Technical Assessment, including transmission by electronic means, shall be in full. However, partial reproduction may only be made with the written consent of the issuing Technical Assessment Body. Any partial reproduction shall be identified as such.

This European Technical Assessment may be withdrawn by the issuing Technical Assessment Body, in particular pursuant to information by the Commission in accordance with Article 25(3) of Regulation (EU) No 305/2011.

Specific Part

1 Technical description of the product

The Cut string stair System Treppenmeister is a prefabricated stair system, which consists of steps, landings, cut strings having and system fasteners. The steps and landings are connected with the strings by system fasteners on both sides.

The steps, landings and cut strings are made of solid wood, the system fasteners are made of steel.

Handrail and barrier are not part of the stair system, but may be attached to the stair optionally according to the individual requirements.

The product description is given in Annex A. The material values, dimensions and tolerances of the components of the stair not indicated in the annexes shall correspond to the values laid down in the technical documentation¹.

2 Specification of the intended use in accordance with the applicable European Assessment Document

The performances given in Section 3 are only valid if the stair is used in compliance with the specifications and conditions given in Annex B.

The verification and assessment methods on which this European Technical Assessment is based lead to the assumption of a working life of the stair of at least 50 years. The indications given on the working life cannot be interpreted as a guarantee given by the producer, but are to be regarded only as a means for choosing the right products in relation to the expected economically reasonable working life of the works.

¹ The technical documentation comprises all information of the holder of this ETA necessary for the production, installation and maintenance of the stair; these are in particular the structural analysis, design drawings and the manufacturer's installation instructions. The part to be treated confidentially is deposited with Deutsches Institut für Bautechnik and, as far as this is relevant to the tasks of the approved bodies involved in the procedure of the AVCP system, shall be handed over to the approved body.

3 Performance of the product and references to the methods used for its assessment

3.1 Mechanical resistance and stability (BWR 1)

Essential characteristic	Performance
Load-bearing capacity of stair	See Annex C2
Load-bearing capacity of fixings	See technical documentation of this European Technical Assessment
Load/displacement behaviour	See Annex C2
Vibration behaviour	First natural frequency: $f_1 \geq 5$ Hz (inclusive a single mass of 100 kg) Deflection under a single load $F = 1$ kN: $w \leq 5$ mm
Prevention of progressive collapse	Failure of individual components of the stair does not lead to a progressive collapse of the complete stair
Residual load-bearing capacity	Local material failure does not lead to an abrupt total loss of load-bearing capacity of the steps.
Long-term behaviour	Load-bearing capacity are ensured under an appropriate use and maintenance over the indicated working life
Resistance to earthquakes	No performance assessed
Durability against physical, chemical and biological agents	Adequate durability for the intended use under an appropriate use and maintenance

3.2 Safety in case of fire (BWR 2)

Essential characteristic	Performance
Reaction to fire	See Annex A4
Fire resistance	No performance assessed

3.3 Hygiene, health and the environment (BWR 3)

Essential characteristic	Performance
Release of formaldehyde	No formaldehyde treated materials are used
Release of pentachlorophenol	No pentachlorophenol treated materials are used
Radioactive emission	Not relevant

3.4 Safety in use (BWR 4)

Essential characteristic	Performance
Geometry	See Annex C1
Slipperiness	No performance assessed
Equipment of the stair for a safe use	No performance assessed
Safe breakage of components	No brittle failure of individual components
Impact resistance	No performance assessed

4 Assessment and verification of constancy of performance (AVCP) system applied, with reference to its legal base

In accordance with the European Assessment Document EAD No. 340006-00-0506 the applicable European legal act is: 1999/89/EC

The System to be applied is: 2+

In addition, with regard to reaction to fire for products covered by the European Assessment Document EAD No. 340006-00-0506 the applicable European legal act is: 2001/596/EC

The System to be applied is: 4

5 Technical details necessary for the implementation of the AVCP system, as provided for in the applicable European Assessment Document

Technical details necessary for the implementation of the AVCP system are laid down in the control plan deposited at Deutsches Institut für Bautechnik.

Issued in Berlin on 14 May 2018 by Deutsches Institut für Bautechnik

BD Dipl.-Ing. Andreas Kummerow
Head of Department

beglaubigt:
P. Stiller

Types of plan

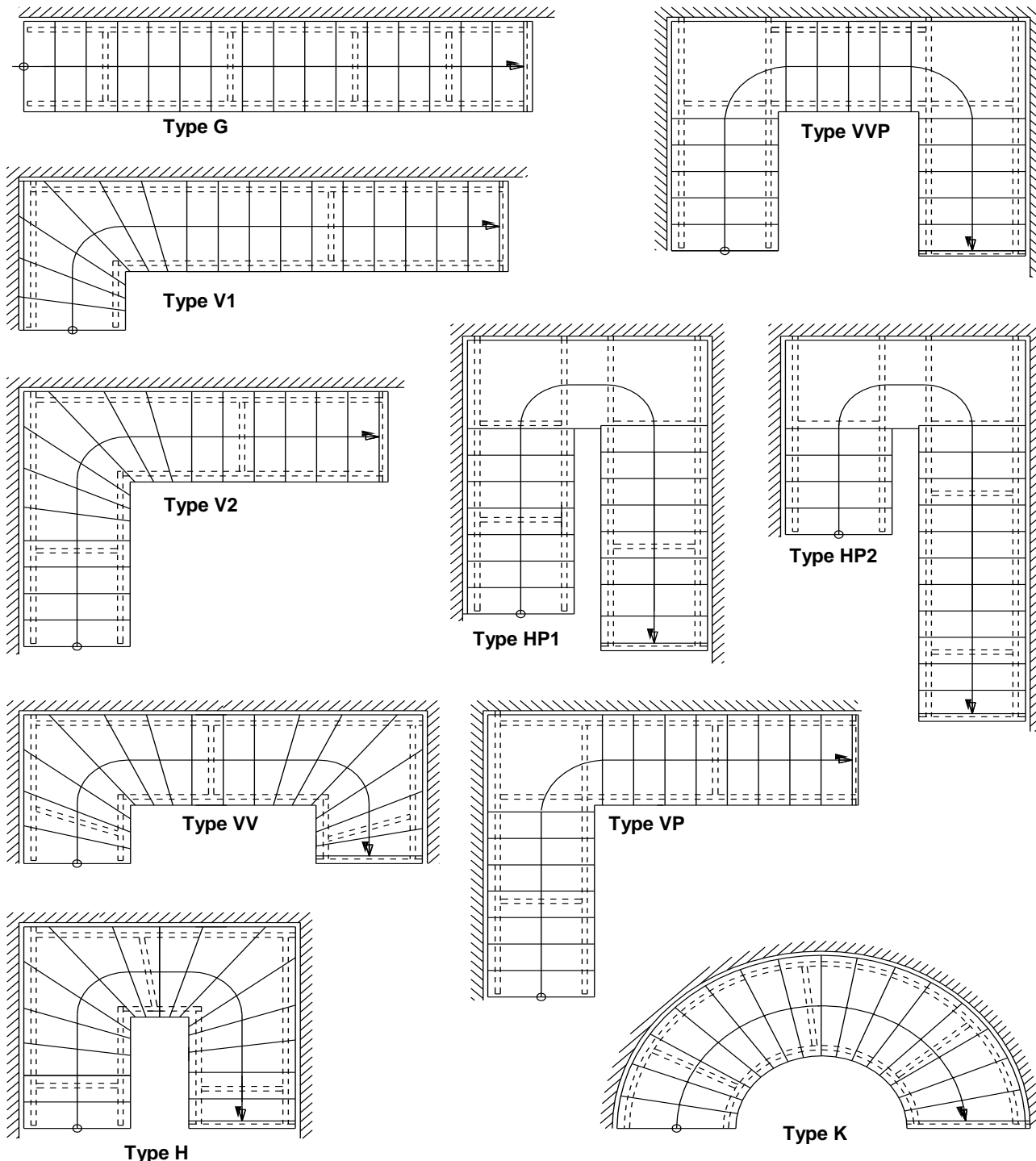

Cut string stair System Treppenmeister

Product (Types of plan)

Annex A1

Types of construction

without riser

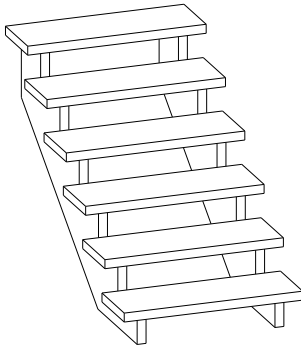

with riser

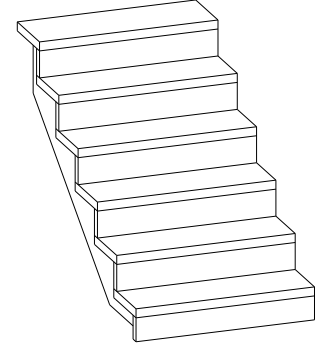
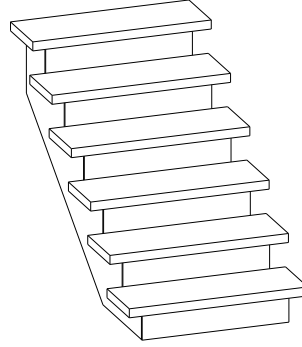

Step – cut string joint

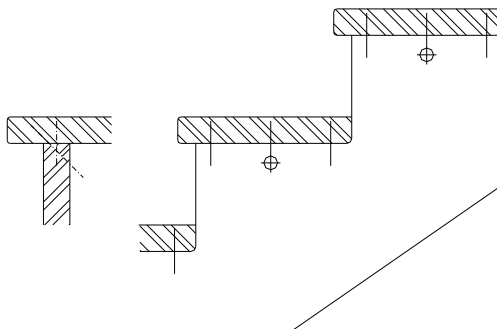

String – string joint

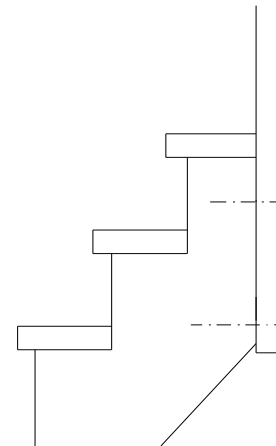

String – cross bracing joint

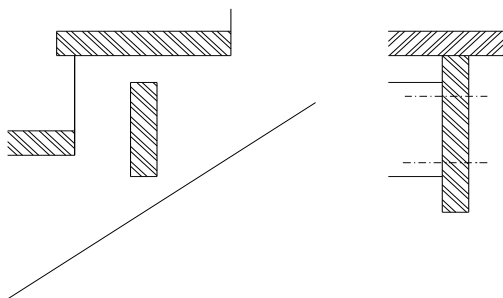

Cut string stair System Treppenmeister

Types of construction, joints: Step – cut string, string - string, string – cross bracing

Annex A2

Joint at bottom

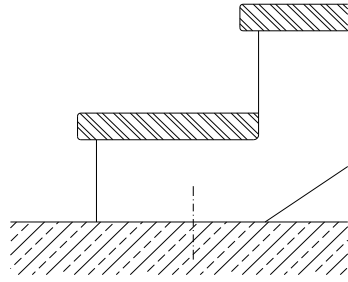

Joint at the top

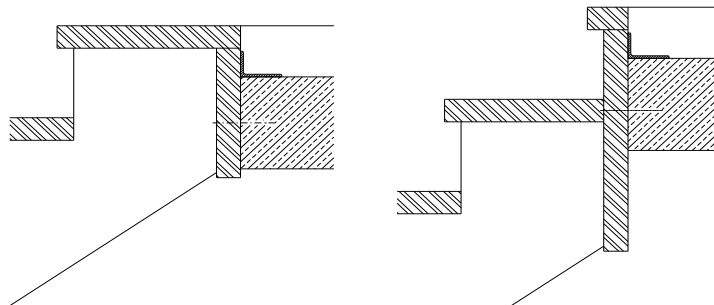

Support of strings at the corner

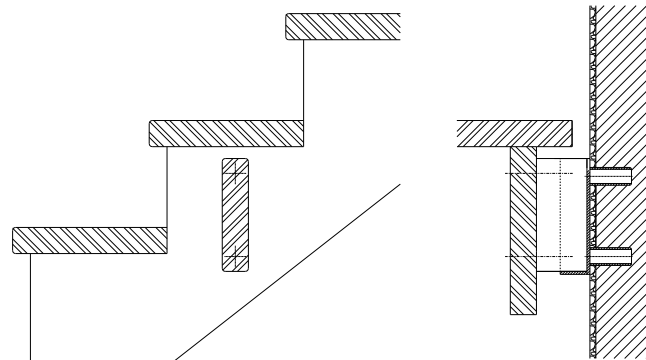

Support of strings of the landings

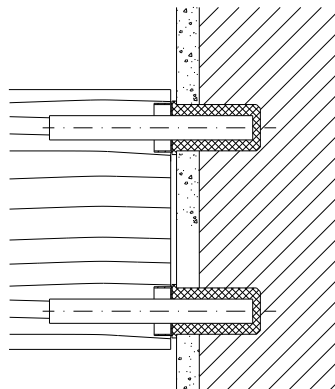

Cut string stair System Treppenmeister

Joints at bottom and at the top, support of strings at the corner and of the landings

Annex A3

Table 1: Minimum dimensions of components of stair and reaction to fire

Component of stair	Material ¹⁾	Dimension		Value	Reaction to fire
Step, landing	Solid wood ²⁾	Thickness	[mm]	44	D-s2, d0
Cut string	Solid wood ²⁾	Width x height	[mm]	44 x 150...210 ³⁾	
Cross bracing	Solid wood ²⁾	Width x height	[mm]	44 x 120	
System fastener, support angles, wall ties	Steel	- ⁴⁾			A1

¹⁾ Materialkennwerte entsprechend technischer Dokumentation

²⁾ Only wood of following species:

Amazakoué, Bangkirai, Bongossi, Beech, Oak, Ash, Iroko/Kambala, Merbau, Wengé, Zebrano

³⁾ Depending on the number of rises and type of plan according to technical documentation

⁴⁾ According to technical documentation

Cut string stair System Treppenmeister

Minimum dimensions of components of the stair and reaction to fire

Annex A4

Specification of intended use (Part 1)

Intended use:

- European Technical Assessment applies for a construction system.
- For the specific case of use the corresponding type of stair is manufactured within the context of the values defined in this European Technical Assessment.
- Values of this ETA apply to all types of stairs, the real dimensions follow in accordance with the relevant case of use.

Stair subject to:

- Static and quasi static loads

Use conditions:

- Indoor stair
- Air temperatures between +5 °C and +30 °C
- Relative air humidity between 30% and 70%
- To the individual requirements handrail and barrier can be attached to the stair optionally. Conditions for possible handrail/barrier:

Dead load ≤ 0.15 kN/m

Height ≤ 1.00 m

Distance of baluster ≤ 0.26 m

Design:

- Design of the stair according to the annexes and the technical documentation of this European Technical Assessment.
- Fastening of the stair to the construction works according to the annexes and the technical documentation of this Technical European Assessment.
- Verification of the transmission of loads to the construction works by the civil engineer responsible for the construction works.
- Load bearing capacity at ultimate limit state:

$$q_k \cdot \gamma_Q \leq q_{RK} / \gamma_M$$

$$Q_k \cdot \gamma_Q \leq Q_{RK} / \gamma_M$$

$$h_k \cdot \gamma_Q \cdot \psi_0 \leq h_{RK} / \gamma_M$$

with

q_{RK}, Q_{RK}, h_{RK} : characteristic values of resistance; see Table 3

γ_M : recommended material partial safety factor; see Table 3

q_k, Q_k, h_k : characteristic values of imposed loads according to EN 1991-1-1:2002 + AC:2009

$\gamma_Q = 1.5$: recommended partial safety factor, in absence of other national regulations

$\psi_0 = 0.7$: recommended combination factor, in absence of other national regulations

- Maximum characteristic values of imposed loads under consideration of the partial factors mentioned above; see Table 5

Cut string stair System Treppenmeister

Specification of intended use (Part 1)

Annex B1

Specification of intended use (Part 2)

Installation:

- Installation by personal appropriately trained and authorized by the manufacturer by means of the technical documentation of this European Technical Assessment
- Installation only in the way as specified in the technical documentation of this European Technical Assessment
- Installation of timber components when moisture content of timber components is $8 \pm 2 \%$
- Sufficient support of the stair when assembling
- Installation of stair components without imposed deformations
- Installation of stair components without significant defects and cracks
- Replacing of stair components, which begin tearing when assembling
- Bolted connection are protected such that they will not be loosened by vibrations

Indication of the manufacturer:

- Ensure that all persons involved will be appropriately informed about the specific conditions according to sections 1 and 2 (including the annexes to which reference is being made as well as the not confidential parts of the technical documentation deposited to this European Technical Assessment)
- Packaging of timber components such that the wood moisture is $8 \pm 2 \%$ during transport and storage
- Instructions for use should provide information as to use, maintenance and repair of the stair. Including the information of avoidance of moisture penetration of the timber components and the information on the relationship between moisture content of timber components, air temperature and relative air humidity

Cut string stair System Treppenmeister

Specification of intended use (Part 2)

Annex B2

Table 2: Geometry

Designation			Dimension	
			minimum	maximum
Going	step on walking line ¹⁾	[mm]	210	370 ²⁾
	tapered step	[mm]	110 ^{2) 3)}	600 ^{2) 4)}
Rise of the stairs ¹⁾		[mm]	140 ²⁾	210
Pitch of the walking line ¹⁾		[°]	21	45
Overlap of steps		[mm]	30	- ⁵⁾
Number of rises		[-]	3	17
Openings	between stairs and wall	[mm]	- ⁵⁾	35
	between consecutive steps	[mm]	- ⁵⁾	166
Clear width of stairs		[mm]	500	1000
Length of the flight		[mm]	- ⁵⁾	4160 ⁶⁾
Thickness of steps		[mm]	44	- ⁵⁾

- 1) Values are constant within one flight
- 2) Tolerance between nominal value and actual value = ± 5 mm
- 3) Wall-free side of tapered step
- 4) Wall side of tapered step
- 5) Not relevant
- 6) Stairs with landings according to technical documentation

- 1 Going**
- 2 Rise**
- 3 Overlap**
- 4 Opening between consecutive steps**
- 5 Length of the flight**
- 6 Thickness of steps**
- 7 Height of the string**
- 8 Cross bracing**

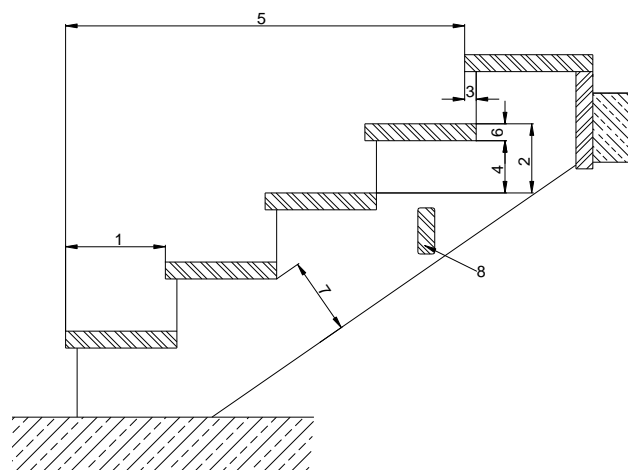

Cut string stair System Treppenmeister

Geometry of the stair

Annex C1

Table 3: Load-bearing capacity - Characteristic values of resistance

Component	Type of loading	Characteristic values of resistance			γ_M
Flight	vertical variable uniformly distributed load	$q_{R,k}$	[kN/m ²]	6.8	1.5 ¹⁾
	vertical variable single load	$Q_{R,k}$	[kN]	4.5	
	horizontal variable uniformly distributed load on barrier	$h_{R,k}$	[kN/m]	0.8	
Joint at the top	vertical variable uniformly distributed load	$q_{R,k}$	[kN/m ²]	5.6	1.25 ²⁾
	vertical variable single load	$Q_{R,k}$	[kN]	3.8	
	horizontal variable uniformly distributed load on barrier	$h_{R,k}$	[kN/m]	0.7	

¹⁾ Recommended partial safety factor (wood decisive), in absence of other national regulations

²⁾ Recommended partial safety factor (wood fastener decisive), in absence of other national regulations

Table 4: Deflections under loading

Deflection of the flight under uniformly distributed load			
uniformly distributed load	q_k	[kN/m ²]	3.0
length of the median line of the flight	L	[mm]	4160 ¹⁾
deflection under load F_S related to the median line of the flight	w	[-]	≤ L/200
Deflection of the step under single point load			
single load	Q_k	[kN]	2.0
clear width of the stair	L	[mm]	1000
deflection under load F_S related to the clear width of the stair	w	[-]	≤ L/200

¹⁾ Stairs with landings according to technical documentation

Table 5: Imposed loads

Type of loading	Imposed loads		
vertical variable uniformly distributed load	q	[kN/m ²]	3.0
vertical variable single load	Q	[kN]	2.0
horizontal variable uniformly distributed load on barrier	h	[kN/m]	0.5

Cut string stair System Treppenmeister

Load-bearing capacity – Characteristic values of resistance,
Deflections under loading,
Imposed loads

Annex C2