

Approval body for construction products  
and types of construction

Bautechnisches Prüfamt

An institution established by the Federal and  
Laender Governments



## European Technical Assessment

ETA-13/0427  
of 19 April 2018

English translation prepared by DIBt - Original version in German language

### General Part

Technical Assessment Body issuing the  
European Technical Assessment:

Deutsches Institut für Bautechnik

Trade name of the construction product

BATI-THERM MW

Product family  
to which the construction product belongs

Product area code: 4  
External Thermal Insulation Composite System with  
rendering on mineral wool for the use as external  
insulation of building walls

Manufacturer

Bati-C S.A.  
30, rue de l'industrie à Bertrange  
8069 LUXEMBURG  
LUXEMBURG

Manufacturing plant

Bati-C S.A.  
30, rue de l'industrie à Bertrange  
8069 LUXEMBURG  
LUXEMBURG

This European Technical Assessment  
contains

19 pages including 4 annexes which form an integral part  
of this assessment

Annex 5 Control Plan contains confidential information  
and is not included in the European Technical  
Assessment when the assessment is publicly available.

This European Technical Assessment is  
issued in accordance with Regulation (EU)  
No 305/2011, on the basis of

ETAG 004, edition 2000, amended 2013e 2000, geändert  
2013,  
used as EAD according to Article 66 Paragraph 3 of  
Regulation (EU) No 305/2011.

**European Technical Assessment  
ETA-13/0427**

**Page 2 of 19 | 19 April 2018**

English translation prepared by DIBt

The European Technical Assessment is issued by the Technical Assessment Body in its official language. Translations of this European Technical Assessment in other languages shall fully correspond to the original issued document and shall be identified as such.

Communication of this European Technical Assessment, including transmission by electronic means, shall be in full. However, partial reproduction may only be made with the written consent of the issuing Technical Assessment Body. Any partial reproduction shall be identified as such.

This European Technical Assessment may be withdrawn by the issuing Technical Assessment Body, in particular pursuant to information by the Commission in accordance with Article 25(3) of Regulation (EU) No 305/2011.

## Specific Part

### 1 Technical description of the product

#### 1.1 Definition of the kit

This product is an External Thermal Insulation Composite System (ETICS) with rendering - a kit comprising components which are factory-produced by the manufacturer or component suppliers. It's made up on site from these. The ETICS manufacturer is ultimately responsible for all components of the ETICS specified in this ETA.

The ETICS kit comprises a prefabricated insulation product of mineral wool (MW) to be bonded and if it necessary additional mechanically fixed onto a wall. The methods of fixing and the relevant components are specified in the table below.

The insulation product is faced with a rendering system consisting of one base coat and finishing coat (site applied), in which the base coat contains reinforcement. The rendering is applied directly to the insulating panels, without any air gap or disconnecting layer.

The ETICS may include special fittings (e.g. base profiles, corner profiles ...) for connection to adjacent building elements (apertures, corners, parapets ...). Assessment and performance of these components is not addressed in this ETA, however the ETICS manufacturer is responsible for adequate compatibility and performance within the ETICS when the components are delivered as a part of the kit.

#### 1.2 Composition of the ETICS

	Components National application documents shall be taken into account	Coverage [kg/m <sup>2</sup> ]	Thickness [mm]
Insulation material with associated method of fixing	<ul style="list-style-type: none"> <li>• <b>Insulation product</b> (see annex 1 for product characteristics) factory-prefabricated mineral wool (MW) product                             <ul style="list-style-type: none"> <li>- MW lamella</li> </ul> </li> <li>• <b>Adhesives</b> <ul style="list-style-type: none"> <li>- <b>Kleber und Armierungsmörtel DS</b> (cement based powder requiring addition of about 25 % of water)</li> </ul> </li> </ul>	<p>–</p> <p>4.0 to 6.0 (prepared)</p>	<p>≤ 200</p> <p>–</p>
	<p><b>Mechanically fixed ETICS with profiles and supplementary adhesive:</b></p> <ul style="list-style-type: none"> <li>• <b>Insulation product</b> (see annex 1 for product characteristics) factory-prefabricated mineral wool (MW) product                             <ul style="list-style-type: none"> <li>- MW panel, <math>\sigma_{mt} \geq 14</math> kPa</li> </ul> </li> <li>• <b>Supplementary adhesive</b> (equal to bonded ETICS)</li> <li>• <b>Profiles</b> (see annex 3 for product characteristics)                             <ul style="list-style-type: none"> <li>– "Halteleisten Alu"</li> <li>– "Verbindungsleisten Alu"</li> </ul> </li> </ul> <p>Aluminium (Al) – profiles</p>	<p>–</p>	<p>60 to 200</p>

	<b>Components</b> National application documents shall be taken into account	<b>Coverage</b> [kg/m <sup>2</sup> ]	<b>Thickness</b> [mm]
<b>Insulation material with associated method of fixing</b>	<ul style="list-style-type: none"> <li>• <b>Anchors for profiles</b> (see annex 2 for product characteristics) <ul style="list-style-type: none"> <li>- WS 8 L</li> <li>- WS 8 N</li> <li>- ejothem SDK U</li> <li>- SDF-K plus</li> <li>- ejothem NK U</li> </ul> </li> <li>• <b>Anchors for insulation product if necessary</b> (equal to mechanically fixed ETICS with anchors and supplementary adhesive, see below)</li> </ul>		
	<p><b>Mechanically fixed ETICS with anchors and supplementary adhesive:</b></p> <ul style="list-style-type: none"> <li>• Insulation product (see annex 1 for product characteristics) factory-prefabricated mineral wool (MW) product <ul style="list-style-type: none"> <li>- MW panel</li> <li>- MW lamella</li> </ul> </li> <li>• <b>Supplementary adhesive</b> (equal to bonded ETICS)</li> <li>• <b>Anchors for insulation product</b> <ul style="list-style-type: none"> <li>- all anchors with ETA according to EAD330196-00-0604<sup>1</sup> with characteristics defined in annex 2</li> </ul> </li> </ul>	<p>–</p> <p>–</p>	<p>60 to 340</p> <p>60 to 200</p>
<b>Base coat</b>	<b>Kleber und Armierungsmörtel DS</b> Identical with the equally named adhesive given above.	6.5 to 13.0 (prepared)	5.0 to 10.0
<b>Glass fibre mesh</b>	<b>WDVS-Gewebe Grob</b> (see annex 4 for product characteristics) Alkali- and slide-resistant glass fibre mesh with mass per unit area of about 210 g/m <sup>2</sup> and mesh size of about 8.0 mm x 8 mm.	–	–
<b>Key coat</b>	<b>Quarzgrundierung</b> Ready to use pigmented liquid - acrylic binder. To be used with all finishing coats indicated hereafter.	ca. 0,200 l/m <sup>2</sup>	–
<b>Finishing coat</b>	<p><b>To use with key coat "Quarzgrundierung" if applicable **::</b></p> <p><b>Application without key coat:</b></p> <ul style="list-style-type: none"> <li>• Thick layered cement based powder requiring addition of about 22 % of water: <b>Edelkratzputz</b> (particle size 2 – 3 mm)</li> </ul>	20.0 to 25.0 (prepared before scraping) about 14.0 (finished)	((von bis bis))

<sup>1</sup>EAD330196-00-0604

Kunststoffdübel zur Befestigung von außenseitigen Wärmedämm-Verbundsystemen mit Putzschicht

	Components National application documents shall be taken into account	Coverage [kg/m <sup>2</sup> ]	Thickness [mm]
	<ul style="list-style-type: none"> <li>Thin layered cement based powder requiring addition of about 27 % of water:                             <ul style="list-style-type: none"> <li><b>Rillenputz</b> (particle size 2 – 3 mm)</li> <li><b>Scheibenputz</b> (particle size 1.5 – 2 – 3 – 4 mm)</li> <li><b>Marmorputz</b> (particle size 0.5 – 1 – 1.5 – 2 – 2.5 mm)</li> </ul> </li> <li>Thin layered cement based powder requiring addition of about 36 to 40 % of water:                             <ul style="list-style-type: none"> <li><b>Leichtedelputz K*</b> (particle size 1.5 – 2 – 3 mm)</li> </ul> </li> <li>Ready to use pastes – acrylic/vinyllic binder:                             <ul style="list-style-type: none"> <li><b>Kunstharz-Fassadenputz K + R*</b> (particle size 1.5 – 2 – 3 – 4 mm)</li> </ul> </li> <li>Ready to use pastes – acrylic/vinyllic/siloxane binder:                             <ul style="list-style-type: none"> <li><b>Silikonharz-Fassadenputz K + R*</b> (particle size 1.5 – 2 – 3 mm)</li> <li><b>Siloxan-Fassadenputz K + R*</b> (particle size 1.5 – 2 – 3 mm)</li> </ul> </li> <li>Ready to use pastes – acrylic/vinyllic/siloxane binder:                             <ul style="list-style-type: none"> <li><b>Silikat-Fassadenputz K + R*</b> (particle size 1.5 – 2 – 3 mm)</li> </ul> </li> </ul>	<p>3.5 to 5.0 (prepared)</p> <p>2.5 to 6.5 (prepared)</p> <p>1.6 to 8.0 (prepared)</p> <p>2.0 to 4.5 (prepared)</p> <p>2.0 bis 4.5 (prepared)</p> <p>2.0 bis 4.0 (prepared)</p> <p>2.0 bis 4.0 (prepared)</p> <p>2.0 bis 3.8 (prepared)</p>	<p>Regulated by particle size</p> <p>1.0 to 5.0</p> <p>Regulated by particle size</p>
<b>Ancillary material</b>	Remains the responsibility of the manufacturer of the ETICS.		
<p>* K / R / MP indicates different structures of the finishing coat.</p> <p>** The instruction to the installer concerning the use of a key coat remains the responsibility of the manufacturer.</p>			

## 2. Specification of the intended use in accordance with the applicable European assessment Document (hereinafter called EAD)

### 2.1 Intended use

This ETICS is intended to be used as external insulation to the walls of buildings made of masonry (bricks, blocks, stones ...) or concrete (cast on site or as prefabricated panels) with and without rendering. The characteristics of the walls shall be verified prior to use of the ETICS, especially regarding conditions for reaction to fire classification and for fixing of the ETICS either by bonding or mechanically. It shall be designed to give the wall to which it is applied satisfactory thermal insulation.

The ETICS is non load-bearing construction element. It does not contribute directly to the stability of the wall on which it is installed, but it can contribute to durability by providing enhanced protection from the effects of weathering.

The ETICS can be used on new or existing (retrofit) vertical walls.

The ETICS is not intended to ensure the air tightness of the building structure.

The choice of the method of fixing depends on the characteristics of the substrate, which could need preparation (see clause 7.2.1 of ETAG 004) and on the national instructions.

The verifications and assessment methods on which this European Technical Assessment (hereinafter called ETA) is based lead to the assumption of a working life of the ETICS "BATI-THERM MW" of at least 25 years. The indications given on the working life cannot be interpreted as a guarantee given by the manufacturer, but are to be regarded only as a means for choosing the right products in relation to the assumed economically reasonable working life of the works.

## 2.2 Manufacturing

The ETA is issued for the ETICS on the basis of agreed data/information, deposited with the DIBt, which identifies the ETICS that has been assessed and judged. Changes to the ETICS or the components or their production process, which could result in this deposited data/information being incorrect, should be notified to the DIBt before the changes are introduced. The DIBt will decide whether such changes affect the approval and consequently the validity of the CE marking on the basis of the approval and if so whether further assessment or alterations to the approval shall be necessary.

## 2.3 Design and installation

The installation instructions including special installation techniques and provisions for the qualification of the personnel are given in the manufacturer's technical documentation.

Design, installation and execution of ETICS are to be in conformity with national documents. Such documents and the level of their implementation in Member States' legislation are different. Therefore, the assessment and declaration of performance are done taking into account general assumptions introduced in the chapters 7.1 and 7.2 of ETAG 004 used as EAD, which summarize how information introduced in the ETA and related documents is intended to be used in the construction process and gives advice to all parties interested when normative documents are missing.

## 2.4 Packing, transport and storage

The information on packaging, transport and storage is given in the manufacturer's technical documentation. It is the responsibility of the manufacturer to ensure that this information is made know to the concerned people.

## 2.5 Use, maintenance, repair

The finishing coat shall normally be maintained in order to fully preserve the ETICS performance. Maintenance includes at least:

- visual inspection of the ETICS
- the repairing of localized damaged areas due to accidents
- the aspect maintenance with products adapted and compatible with the ETICS (possibly after washing or ad hoc preparation)

Only products which are compatible with the ETICS shall be used.

Necessary repairs should be performed as soon as the need has been identified.

The information on use, maintenance and repair is given in the manufacturer's technical documentation.

It is the responsibility of the manufacturer to ensure that this information is made know to the concerned people.

### 3 Characteristics of products and methods of verification

#### 3.0 General

The performances of the kit as described in this chapter are valid provided that the components of the kit comply with Annexes 1 to 4

#### 3.1 Mechanical resistance and stability (BWR 1)

not relevant

#### 3.2 Safety in case of fire (BWR 2)

##### Reaction to fire (ETAG 004 - clause 5.1.2)

Configurations	Organic content	Flame retardant content	Euroclass according to EN 13501-1:2007
Base coat	max. 2.4 %	no flame retardant	
Mineral wool insulation product	in quantity ensuring Euroclass E according to EN 13501-1	no flame retardant	
Profile	-	-	
Anchors	-	-	
<b>rendering system :</b> Base coat with finishing coat and compatible key coat indicated hereafter			
Edelkratzputz Rillenputz Scheibenputz Marmorputz Leichtedelputz K jeder mit Quarzgrundierung	max. 1.2 %	no flame retardant	A2 – s1,d0
Kunstharz-Fassadenputz K + R Silikonharz-Fassadenputz K + R Siloxan-Fassadenputz K + R Silikat-Fassadenputz K + R jeder mit Quarzgrundierung	max. 9.7 %	min. 3 %	

#### 3.3 Hygiene, health and environment (BWR 3)

##### 3.3.1 Water absorption (capillarity test) (ETAG 004 – clause 5.1.3.1)

###### Base coat:

- Water absorption after 1 hour < 1.0 kg/m<sup>2</sup>
- Water absorption after 24 hours < 0.5 kg/m<sup>2</sup>

English translation prepared by DIBt

**Rendering system:**

		Water absorption after 24 hours	
		< 0.5 kg/m <sup>2</sup>	≥ 0.5 kg/m <sup>2</sup>
<b>Rendering systems:</b> Base coat with finishing coat and compatible key coat indicated hereafter	Edelkratzputz mit Quarzgrundierung	x	
	Rillenputz mit Quarzgrundierung	x	
	Scheibenputz mit Quarzgrundierung	x	
	Marmorputz mit Quarzgrundierung	x	
	Leichtedelputz K mit Quarzgrundierung	x	
	Kunstharz-Fassadenputz K + R mit Quarzgrundierung	x	
	Silikonharz-Fassadenputz K + R mit Quarzgrundierung	x	
	Siloxan-Fassadenputz K + R mit Quarzgrundierung	x	
	Silikat-Fassadenputz K + R mit Quarzgrundierung	x	

**3.3.2 Hygrothermal behaviour (ETAG 004 – clause 5.1.3.2)**

Pass (without defects)

**3.3.3 Impact resistance (ETAG 004 – clause 5.1.3.3)**

<b>Rendering system:</b> Base coat with finishing coat and compatible key coat as indicated in clause 1.2	<b>Single standard mesh: "WDVS-Gewebe Grob"</b>
Edelkratzputz	Category I
Rillenputz	Category II
Scheibenputz	Category II
Marmorputz	Category II
Leichtedelputz K	Category II
Kunstharz-Fassadenputz K + R	Category II
Silikonharz-Fassadenputz K + R	Category I
Siloxan-Fassadenputz K + R	Category I
Silikat-Fassadenputz K + R	Category II



### 3.3.4 Water vapour permeability (ETAG 004 – clause 5.1.3.4)

Rendering system: Base coat with finishing coat indicated hereafter (evaluated without key coat)	Equivalent air thickness $s_d$
Edelkratzputz	$\leq 1.0$ m (Test result obtained with a layer thickness 13 mm: 0.17 m)
Rillenputz	$\leq 1.0$ m (Test result obtained with a layer thickness 3 mm: 0.20 m)
Scheibenputz	$\leq 1.0$ m (Test result obtained with a layer thickness 3 mm: 0.11 m)
Marmorputz	$\leq 1.0$ m (Test result obtained with a layer thickness 2,5 mm: 0.22 m)
Leichtedelputz K	$\leq 1.0$ m (Test result obtained with a layer thickness 3 mm: 0.23 m)
Kunstharz-Fassadenputz K + R	$\leq 1.0$ m (Test result obtained with a layer thickness 2 mm: 0.26 m)
Silikonharz-Fassadenputz K + R	$\leq 1.0$ m (Test result obtained with a layer thickness 2 mm: 0.24 m)
Siloxan-Fassadenputz K + R	$\leq 1.0$ m (Test result obtained with a layer thickness 2 mm: 0.22 m)
Silikat-Fassadenputz K + R	$\leq 1.0$ m (Test result obtained with a layer thickness 2 mm: 0.12 m)

### 3.3.5 Release of dangerous substances (ETAG 004 – clause 5.1.3.5, EOTA TR 034)

Essential characteristic	Performance
Release of dangerous substances	no performance assessed

## 3.4 Safety and accessibility in use (BWR 4)

### 3.4.1 Bond strength between base coat and insulation product (MW) (ETAG 004 – clause 5.1.4.1.1)

Conditioning		
Initial state	After hygrothermal cycles	After freeze/thaw test
$\geq 0.08$ MPa	$< 0.08$ MPa but failure in the insulation product	Test not required because freeze/thaw cycles not necessary

English translation prepared by DIBt

**3.4.2 Bond strength between adhesive and substrate resp. insulation product (MW lamella) (ETAG 004 – clauses 5.1.4.1.2 and 5.1.4.1.3)**

Adhesive	Substrate resp. insulation product	Conditioning		
		Initial state	2 d immersion in water and 2 h drying	2 d immersion in water and 7 d drying
Kleber- und Armierungsmörtel DS	Concrete	≥ 0.25 MPa	≥ 0.08 MPa	≥ 0.25 MPa
	MW lamella	≥ 0.08 MPa	≥ 0.03 MPa	≥ 0.08 MPa

Bonded surface:

With a bonded surface of 40 % the formula given in clause 6.1.4.1.3 of ETAG 004 is fulfilled and the use as bonded ETICS is possible.

**3.4.3 Bond strength after ageing (ETAG 004 – clause 5.1.7.1):**

<b>Rendering system:</b> Base coat with finishing coat indicated hereafter	Edelkratzputz*	< 0,08 MPa
	Rillenputz	< 0,08 MPa aber Versagen beim Dämmstoff
	Scheibenputz	
	Marmorputz	
	Leichtedelputz	
	Kunstharz- Fassadenputz K + R	
	Silikonharz- Fassadenputz K + R	
	Siloxan- Fassadenputz K + R	
	Silikat- Fassadenputz K + R	

\* cohesion rupture inside finishing coat

**3.4.4 Fixing strength (displacement test) (ETAG 004 – clause 5.1.4.2)**

Test not required therefore no limitation of ETICS length required.

**3.4.5 Wind load resistance (ETAG 004 – clause 5.1.4.3)**

The following failure loads only apply to the listed combination of component characteristics and the characteristics of the insulation product given in annex 1.

**3.4.5.1 Safety in use of mechanically fixed ETICS using profiles**

Failure loads – Table 1

Characteristics of the MW panels	Dimensions	625 mm x 800 mm
	Thickness	≥ 60 mm
	<b>Tensile strength perpendicular to the faces</b>	<b>≥ 14 kPa</b>
Failure loads [N/panel] (Static Foam Block Test)	Horizontal profiles with a vertical distance of 625 mm, fixed every 30 cm and vertical connection profiles <b>No additional anchors in MW panel</b>	Mindestwert: 1200 Mittelwert: 1250

English translation prepared by DIBt

Failure loads – Table 2

Characteristics of the <b>MW panels</b>	Dimensions	625 mm x 800 mm
	Thickness	≥ 60 mm
	<b>Tensile strength perpendicular to the faces</b>	<b>≥ 14 kPa</b>
Failure loads [N/panel] (Static Foam Block Test)	Horizontal profiles with a vertical distance of 625 mm, fixed every 30 cm and vertical connection profiles <b>Two additional anchors per MW panel,</b> plate diameter ≥ 60 mm, mounted on the MW panel surface	Mindestwert: 2200 Mittelwert: 2400

3.4.5.2 Safety in use of mechanically fixed ETICS using anchors

Failure loads – Table 3

Apply to all anchors listed in the clause 1.2 mounted on the insulation panels surface			
Characteristics of the <b>MW panels</b>	Thickness		≥ 60 mm
	<b>Tensile strength perpendicular to the faces</b>		<b>≥ 14 kPa</b>
Versagenslast [N]	Anchors not placed at the panel joints (Static Foam Block Test)	$R_{\text{panel}}$	Mindestwert: 650 Mittelwert: 740
	Anchors placed at the panel joints (Static Foam Block Test)	$R_{\text{joint}}$	Mindestwert: 590 Mittelwert: 610
	Anchors not placed at the panel joints (Pull-through test, dry conditions)	$R_{\text{panel}}$	Mindestwert: 640 Mittelwert: 690
	Anchors not placed at the panel joints (Pull-through test, wet conditions) - series 2* - series 3*	$R_{\text{panel}}$	Mindestwert: 360 Mittelwert: 390 Mindestwert: 410 Mittelwert: 450

\* according to ETAG 004 clause 5.2.4.1.2 test method (2)

English translation prepared by DIBt

Failure loads – Table 4

Apply to all anchors listed in the clause 1.2 mounted on the insulation panels surface				
Characteristics of the MW panels	Thickness		≥ 80 mm	
	Tensile strength perpendicular to the faces		≥ 5.0 kPa	
Plate diameter of anchor			≥ Ø 90 mm	≥ Ø 140 mm
Failure loads [N]	Anchors not placed at the panel joints (Static Foam Block Test)	R <sub>panel</sub>	Minimal: 480 Average: 490	Minimal: 560 Average: 690
	Anchors placed at the panel joints (Static Foam Block Test)	R <sub>joint</sub>	Minimal: 380 Average: 390	Minimal: 440 Average: 540
	Anchors not placed at the panel joints (Pull-through test, dry conditions)	R <sub>panel</sub>	Minimal: 540 Average: 610	npd
	Anchors not placed at the panel joints (Pull-through test, wet conditions) - series 2*	R <sub>panel</sub>	Minimal: 400 Average: 460	npd
* according to ETAG 004 clause 5.2.4.1.2 test method (2)				

Failure loads – Table 5

Apply to all anchors listed in clause 1.2 mounted on the insulation panels surface			
Characteristics of the MW lamella	Thickness		≥ 60 mm
	Tensile strength perpendicular to the faces		≥ 80 kPa
Plate diameter of anchor			≥ Ø 140 mm
Failure loads [N]	Anchors placed at the panel joints (Pull-through test, dry condition)	R <sub>joint</sub>	Minimal: 620 Average: 660
	Anchors placed at the panel joints (Pull-through test, wet condition)	R <sub>joint</sub>	Minimal: 510 Average: 570
	Anchors placed at the panel joints (Static Foam Block Test)	R <sub>joint</sub>	Minimal: 710

The failure loads of tables 2 and 3 specified above only apply to the following anchors with deep mounting under the given conditions of installation:

Anchor	Thickness of the MW panel [d]	Conditions of installation *
ejotherm STR U ejotherm STR U 2G (ETA-04/0023)	100 mm > d ≥ 80 mm	– Maximum installation depth of the anchor plate: 15 mm (≙ thickness of insulation cover) – Maximum depth of die: 5 mm
	≥ 100 mm	– Maximum installation depth of the anchor plate: 15 mm (≙ thickness of insulation cover) – Maximum depth of die: 20 mm
TERMOZ 8 SV (ETA-06/0180)	≥ 80 mm	– Maximum installation depth of the anchor plate: 15 mm (≙ thickness of insulation cover)
* according to the appropriate ETA of anchor		

English translation prepared by DIBt

### 3.4.6 Render strip tensile test (ETAG 004 – clause 5.5.4.1)

No performance determined for the width of cracks.

### 3.5 Protection against noise (BWR 5)

For the protection against noise no performance was assessed for this product.

### 3.6 Energy economy and heat retention (BWR 6)

#### 3.6.1 Thermal resistance

The nominal value of the additional thermal resistance  $R$  provided by the ETICS to the substrate wall is calculated in accordance with EN ISO 6946:2007 from the nominal value of the insulation product's thermal resistance  $R_D$  given accompanied to the CE marking and from the thermal resistance of the rendering system  $R_{render}$  which is about  $0.02 \text{ (m}^2 \cdot \text{K)/W}$ .

$$R = R_D + R_{render}$$

The thermal bridges caused by mechanical fixing devices (anchors profiles) increase the thermal transmittance  $U$ . This influence had to take into account according to EN ISO 6946:2007.

$U_c = U + \Delta U$	corrected thermal transmittance [ $\text{W}/(\text{m}^2 \cdot \text{K})$ ]
$\Delta U = \Delta U_{anchor} + \Delta U_{profile}$	correction term for mechanical fixing devices (anchors, profiles)
$\Delta U_{anchor} = \chi_p \cdot n$	correction term for anchors
where: $n$	number of anchors per $\text{m}^2$
$\chi_p$	local influence of thermal bridge caused by an anchor. The values listed below can be taken into account, if not specified in the anchor's technical approval
$\chi_p = 0.004 \text{ W/K}$	for anchors with a galvanized steel screw with the head covered by a plastic material
$\chi_p = 0.002 \text{ W/K}$	for anchors with a stainless steel screw with the head covered by plastic material, and for anchors with an air gap at the head of the screw
$\Delta U_{profile} = \Psi \cdot l$	correction term for profiles; $\Delta U_{profile}$ is determined in accordance with EN ISO 10211:2007
where: $\Psi$	length thermal transmittance value of the profile [ $\text{W}/(\text{m} \cdot \text{K})$ ]
$l$	length of profile per $\text{m}^2$ [ $\text{m}/\text{m}^2$ ]

English translation prepared by DIBt

**4 Assessment and verification of constancy of performance (AVCP) system applied, with reference to its legal base**

According to the European Commission decision 97/556/EC amended by the European Commission decision 2001/596/EC, the assessment and verification of constancy of performance system (AVCP) applies suitable following table (see Annex V to Regulation (EU) No 305/2011).

Product	Intended use	Levels or classes (Reaction to fire)	Systems
" BATI-Therm MW "	in external wall subject to fire regulations	A1 <sup>(1)</sup> , A2 <sup>(1)</sup> , B <sup>(1)</sup> , C <sup>(1)</sup>	1
		A1 <sup>(2)</sup> , A2 <sup>(2)</sup> , B <sup>(2)</sup> , C <sup>(2)</sup> , D, E, (A1 to E) <sup>(3)</sup> , F	2+
	in external wall not subject to fire regulations	any	2+
<sup>(1)</sup> Products/materials for which a clearly identifiable stage in the production process results in an improvement of the reaction to fire classification (e.g. an addition of fire retardants or a limiting of organic material) <sup>(2)</sup> Products/materials not covered by footnote (1) <sup>(3)</sup> Products/materials that do not require to be tested for reaction to fire (e.g. products/materials of Classes A1 according to Commission Decision 96/603/EC)			

**5 Technical details necessary for the implementation of the AVCP system, as provided for in the applicable European Assessment Document (EAD)**

Technical details necessary for the implementation of the AVCP system are laid down in the control plan deposited at Deutsches Institut für Bautechnik.

Issued in Berlin on 19 April 2018 by Deutsches Institut für Bautechnik

Dirk Brandenburger  
Head of Department

*beglaubigt:*  
Hartstock

**European Technical Assessment**  
**ETA-13/0427**  
English translation prepared by DIBt

Page 15 of 19 | 19 April 2018

**Annexes:**

- Annex 1: Thermal insulation product characteristic
- Annex 2: Anchors
- Annex 3: Profiles
- Annex 4: Reinforcement

English translation prepared by DIBt

**Annex 1: Thermal insulation product characteristic**

Factory-prefabricated panels and lamella made of mineral wool (MW) to EN 13162:2015 with the following designation code and the other properties having the description in the Table below shall be used, provided that the manufacturer and the trade name of the MW are deposited with the DIBt.

MW – EN 13162 – T5 – DS(T+) – WS – WL(P) – MU1

Description and characteristics	MW panel	MW panel	MW lamella
Reaction to fire; EN 13501-1:2007	Class A1		
Gross heat of combustion [MJ/kg]; EN ISO 1716:2010	PCS ≤ 1.02		
Thermal resistance [(m <sup>2</sup> · K)/W]	Defined in the CE marking in reference to EN 13162:2008		
Tensile strength perpendicular to the faces [kPa]; EN 1607:2013 - in dry conditions*	$\sigma_{mt} \geq 14$	$\sigma_{mt} \geq 5$	$\sigma_{mt} \geq 80$
- in wet conditions** Average value - series 2 - series 3	≥ 33 % of average value in dry conditions ≥ 50 % of average value in dry conditions		
Compressive strength* [kPa]; EN 826:2013	$\sigma_m \geq 40$	$\sigma_m \geq 4$	$\sigma_m \geq 40$
Apparent density [kg/m <sup>3</sup> ]; EN 1602:2013	$120 \leq \rho_a \leq 150$	$100 \leq \rho_a \leq 150$	$80 \leq \rho_a \leq 150$
Shear strength* [kPa]; EN 12090:2013	$20 \leq f_{tk} \leq 100$	$6 \leq f_{tk} \leq 100$	$20 \leq f_{tk} \leq 100$
Shear modulus [MPa]; EN 12090:2013	$1.0 \leq G_m \leq 2.0$	$0.3 \leq G_m \leq 2.0$	$1.0 \leq G_m \leq 2.0$
* Minimal value of all single values ** According to ETAG 004 clause 5.2.4.1.2 test method (2) **** Thermal insulation materials for mechanically fixed ETICS with profiles must circumferentially at the edges, 24 mm from the inner surface, get an approx. 3 mm wide and 13 to 18 mm deep groove cut-in at the factory.			



## Annex 2: Anchors

All anchors with ETA according to EAD330196-00-0604<sup>1</sup> with characteristics having the description below shall be used in the mechanically fixed ETICS:

- plate diameter of anchor  $\geq 60$  mm resp.  $\geq 90$  mm or  $\geq 140$  mm
- plate stiffness  $\geq 0.3$  kN/mm
- load resistance of the anchor plate  $\geq 1.0$  kN

These characteristics and the characteristic tension resistance of the anchors shall be taken from the corresponding ETA.

The anchors listed in the Table in clause 1.2 with reference to the respective ETA shall be used in the mechanically fixed ETICS with profiles for fixing the horizontal profiles.

Trade name	ETA-number
WS 8 L	ETA-02/0019
WS 8 N	ETA-03/0019
IsoFux ND-8Z	ETA-04/0032
SDF-K plus	ETA-04/0064
ejotherm NK U	ETA-05/0009

### Annex 3: Profiles

Aluminium (Al) profiles, EN AW-6060 T66 to EN 755-2: are to be used in the mechanically fixed ETICS with profiles.

The Pull-through resistance of fixings from profiles is  $\geq 500$  N.

#### Horizontal profile – "Halteleiste Alu" (dimensions in millimetres)

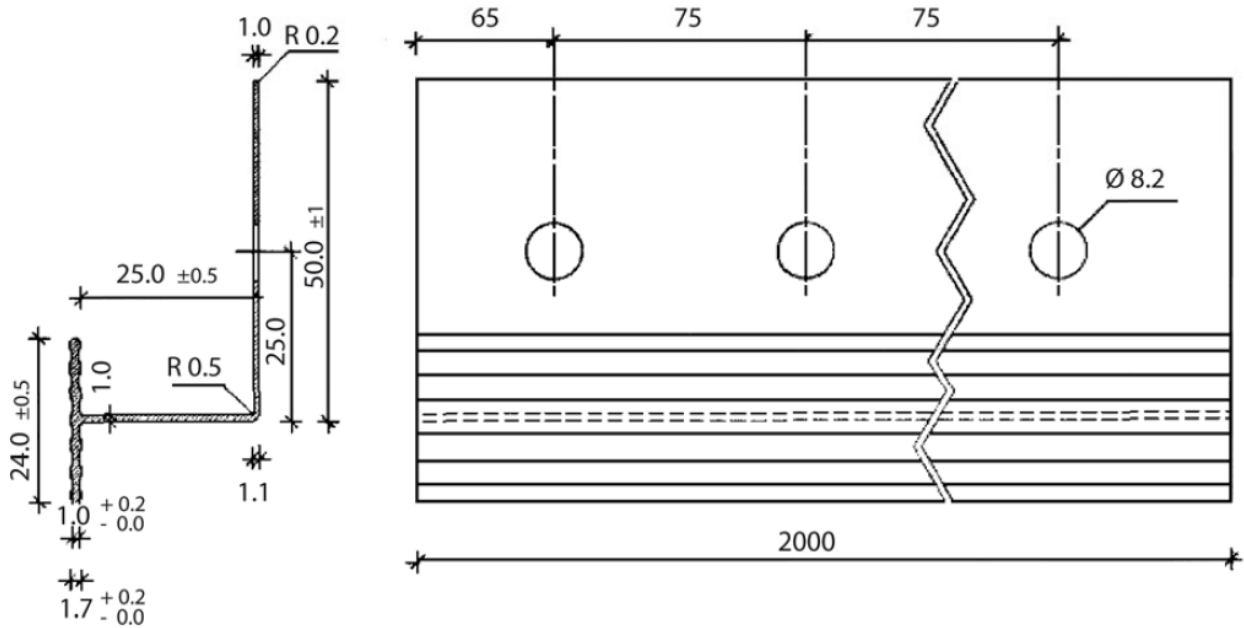

#### Vertical connection profile – "Verbindungsleiste Alu" (dimensions in millimetres)

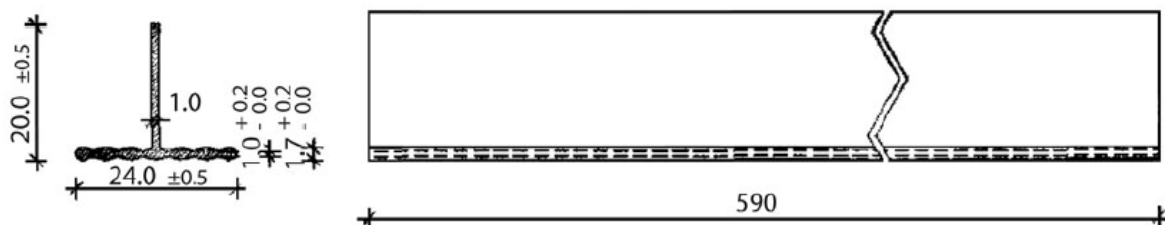

**Annex 4: Reinforcement (glass fibre mesh)**

Characteristics (alkali resistance): Pass

	Description	Residual strength after ageing [N/mm]	Relative residual strength after ageing, of the strength in the as-delivered state [%]
"WDVS-Gewebe grob"	Alkali- and slide-resistant glass fibre mesh with mass per unit area of about 210 g/m <sup>2</sup> and mesh size of about 8.0 mm x 8.0 mm	≥ 20	≥ 50