

Approval body for construction products
and types of construction

Bautechnisches Prüfamt

An institution established by the Federal and
Laender Governments



European Technical Assessment

ETA-13/0906
of 28 September 2018

English translation prepared by DIBt - Original version in German language

General Part

Technical Assessment Body issuing the
European Technical Assessment:

Deutsches Institut für Bautechnik

Trade name of the construction product

Pacifyre® AWM II / Pacifyre® AWM III

Product family
to which the construction product belongs

Pipe collar

Manufacturer

J. van Walraven Holding B.V.
Industrieweg 5
3641 RK Mijdrecht
NIEDERLANDE

Manufacturing plant

Walraven Factory S2

This European Technical Assessment
contains

12 pages including 8 annexes which form an integral part
of this assessment

This European Technical Assessment is
issued in accordance with Regulation (EU)
No 305/2011, on the basis of

EAD 350454-00-1104

This version replaces

ETA-13/0906 issued on 28 June 2013

The European Technical Assessment is issued by the Technical Assessment Body in its official language. Translations of this European Technical Assessment in other languages shall fully correspond to the original issued document and shall be identified as such.

Communication of this European Technical Assessment, including transmission by electronic means, shall be in full. However, partial reproduction may only be made with the written consent of the issuing Technical Assessment Body. Any partial reproduction shall be identified as such.

This European Technical Assessment may be withdrawn by the issuing Technical Assessment Body, in particular pursuant to information by the Commission in accordance with Article 25(3) of Regulation (EU) No 305/2011.

Specific Part

1 Technical description of the product

"Pacifyre[®] AWM II / Pacifyre[®] AWM III" is a pipe collar consisting of a pipe collar enclosure and a fire-protective inlay.

The pipe collar enclosure is made of sheet steel and needs to be sufficiently protected against corrosion. The fire-protective inlay is made of an intumescent material, which expands under heat exposure.

The pipe collar has the dimensions given in Annexes 2 to 4.

A detailed technical description of the fire safety related performance criteria for the construction products is given in Annexes 1 to 4. Detailed information on the construction product's components is deposited with Deutsches Institut für Bautechnik.

NOTE:

The characteristics listed are suitable both for identifying the construction products as well as for performing the manufacturer's factory production control.

2 Specification of the intended use in accordance with the applicable European Assessment Document

"Pacifyre[®] AWM II / Pacifyre[®] AWM III" is intended for use as a component of a pipe penetration seal for plastic pipes.

Pipe penetration seals are used to seal openings in fire-resistant walls and floors, which are penetrated by pipes. Their aim is to preserve the walls' or floors' fire resistance in the area of the penetrations.

This ETA has served to verify the resistance to fire of pipe penetration seals containing two pipe collars (for wall installations) or one pipe collar (for floor installations). The pipe penetration seals also consisted of a seal between the penetrating pipe and the circular edge of the surrounding building component.

More detailed information and data on the verified penetration seals are given in annexes 5 to 8. The construction product "Pacifyre[®] AWM II / Pacifyre[®] AWM III" may be used for penetration seals of use category X (outdoor use – rain, UV light, frost) provided that the other components of the penetration seal, which are not the subject of this ETA, meet the durability requirements. The resistance to fire of the penetration seals shall be verified on a case-by case basis.

The performances given in Section 3 apply exclusively to the penetration seals assessed as part of the ETA procedure (e.g. with respect to the design and arrangement of the penetration seals' components as well as the type and position of the services).

English translation prepared by DIBt

3 Performance of the product and references to the methods used for its assessment

3.1 Intended use: use in penetration seals

3.2 Safety in case of fire (BWR 2)

Essential characteristic	Performance
Resistance to fire of a penetration seal containing the product	The resistance to fire depends on the design and installation of the penetration seal and on the other components that make up the penetration seal. More details on the tested penetration seals and the related fire resistance classes are given in Annexes 1 to 8.

4 Assessment and verification of constancy of performance (AVCP) system applied, with reference to its legal base

In accordance with European Assessment Document (EAD) no. 350454-00-1104, the following legal base shall apply: 1999/454/EC.

The system to be applied is: system 1.

5 Technical details necessary for the implementation of the AVCP system, as provided for in the applicable EAD

Technical details necessary for the implementation of the AVCP system are laid down in the control plan deposited with Deutsches Institut für Bautechnik.

Issued in Berlin on 28 September 2018 by Deutsches Institut für Bautechnik

Prof. Gunter Hoppe
Head of Department

beglaubigt:
Bisemeier

The factory manufactured construction product pipe collar "Pacifyre® AWM II / Pacifyre® AWM III" consists of a pipe collar steel housing and an insert of an intumescent building material which is incorporated in multiple layers in the pipe collar housing.

**Properties and performance criteria of the components of the construction product
"Pacifyre® AWM II / Pacifyre® AWM III"**

Component	Description
"Pipe collar housing"	Dimensions: see Annexes 2 to 4 Material: sheet steel Classification of the fire behavior: Class A1 according to the commission decision 96/603/EC (current version)
"Insert"	Dimensions: see Annexes 2 to 4 Material: Intumescent building material according to ETA-10/0117 Classification of the fire behavior according to EN 13501-1: Class E

The properties listed can be used for the identification of the construction product and for the implementation of the factory production control of the manufacturer.

Implementation details for the factory production control are included in the inspection plan.

Description of the additional components of the tested sealings

Sealing of the residual joint between pipe collar and soffit: Cement mortar	Material: Cement mortar Classification of the fire behavior: Class A1 according to the commission decision 96/603/EC (in the current version)
--	--

**Performance of penetration seals, comprising the construction product
"Pacifyre® AWM II / Pacifyre® AWM III"**

	Essential requirement	Test method	Construction of the sample	Performance acc. to EN 13501-2
1	Resistance to fire	EN 1366-3	100 mm thick rigid wall; design and layout of the penetration seal according to Annex 5	EI 240-U/C
2	Resistance to fire	EN 1366-3	100 mm thick flexible wall; design and layout of the penetration seal according to Annex 6	EI 120-U/C
3	Resistance to fire	EN 1366-3	300 mm thick rigid floor; design and layout of the penetration seal according to Annex 7	EI 180-U/C bzw. E 240-U/C
4	Resistance to fire	EN 1366-3	150 mm thick floor; design and layout of the penetration seal according to Annex 8	EI 120-U/U

The tested/ illustrated seals are only examples for the use.

The illustrations are without guarantee for completeness.

The use of the construction product "Pacifyre® AWM II / Pacifyre® AWM III" in penetration seals shall be in accordance with national requirements for planning, design and execution and in accordance with the installation instruction of the manufacturer.

Pacifyre® AWM II / Pacifyre® AWM III

Description of the construction products, properties and performances

Annex 1

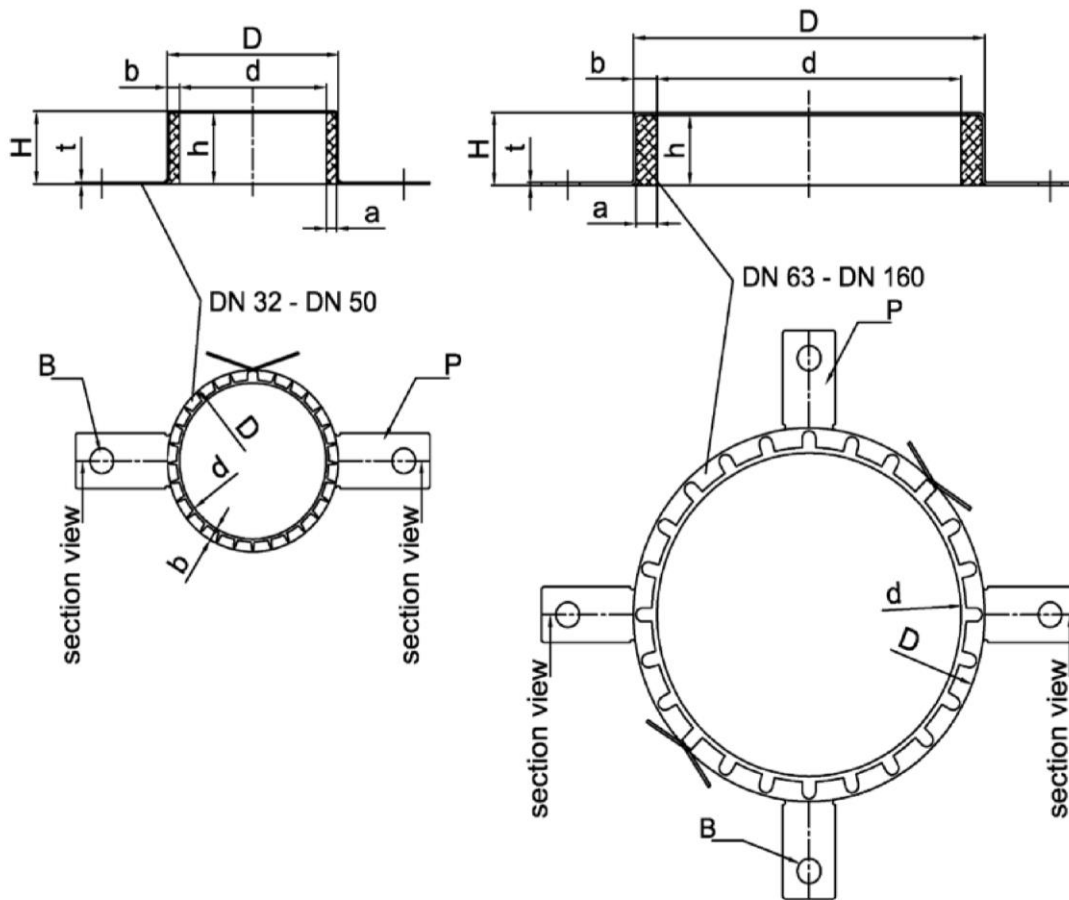

Pipe collar „Pacifyre® AWM II / Pacifyre® AWM III“
in the dimensions AWM III

dA [mm]	d [mm]	D [mm]	b [mm]	t [mm]	H [mm]	P [Stck]	h [mm]	a [mm]	B [mm]
32	38	47	4,6	0,6	26,0	2	25,0	4,0 -0/+0,8	9,0
40	46	55	4,6	0,6	26,0	2	25,0	4,0 -0/+0,8	9,0
50	56	65	4,6	0,6	26,0	2	25,0	4,0 -0/+0,8	9,0
63	69	82	6,6	0,6	26,0	4	25,4	6,0 -0+1,0	9,0
75	81	94	6,6	0,6	26,0	4	25,4	6,0 -0+1,0	9,0
90	96	114	9,0	1,0	26,6	4	25,4	8,0 -0+1,5	9,0
110	116	134	9,0	1,0	26,6	4	25,4	8,0 -0+1,5	9,0
125	132	150	9,0	1,0	26,6	4	38,0	10 -0+2,0	9,0
140	144	168	12	1,0	40,0	4	38,0	10 -0+2,0	9,0
160	164	188	12	1,0	40	4	38,0	10 -0+2,0	9,0

Pacifyre® AWM II / Pacifyre® AWM III

Design of the pipe collar in the size Pacifyre® AWM III

Annex 2

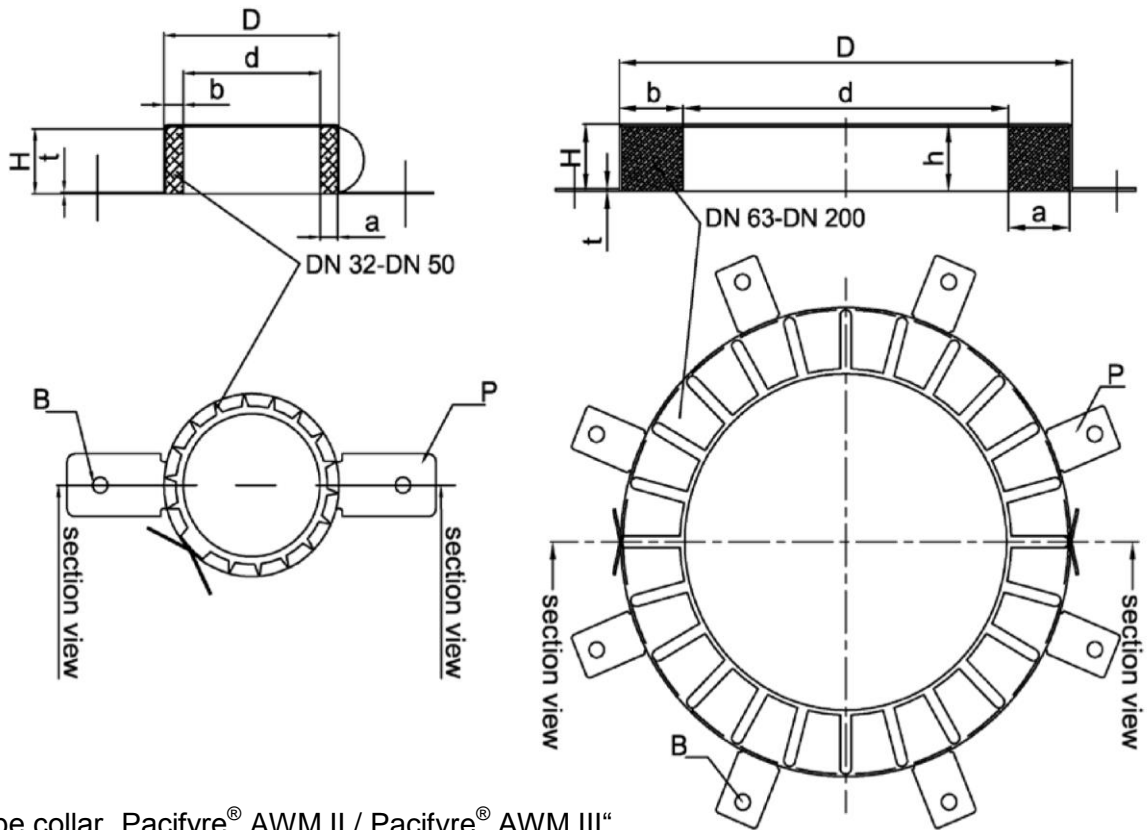

Pipe collar „Pacifyre® AWM II / Pacifyre® AWM III“
in the dimensions AWM II

dA [mm]	d [mm]	D [mm]	b [mm]	t [mm]	H [mm]	P [Stck]	h [mm]	a [mm]	B [mm]
32	36	50	7,0	0,6	26,0	2	25,4	6,4 $\pm 0,5$	6,0
40	44	58	7,0	0,6	26,0	2	25,4	6,4 $\pm 0,5$	6,0
50	54	68	7,0	0,6	26,0	2	25,4	6,4 $\pm 0,5$	6,0
63	67	94	13,5	0,6	26,0	4	25,4	12,8 $\pm 1,0$	6,0
75	79	106	13,5	0,6	26,0	4	25,4	12,8 $\pm 1,0$	6,0
90	94	132	18,3	1,1	26,6	4	25,4	17,1 $\pm 1,0$	9,0
110	114	155	20,5	1,1	26,6	4	25,4	19,2 $\pm 1,5$	9,0
125	129	172	20,5	1,1	40,0	4	38,1	19,2 $-0/+1,5$	9,0
140	144	200	28,0	1,1	40,0	4	38,1	25,6 $-0/+2,0$	9,0
160	164	220	28,0	1,1	40,0	4	38,1	25,6 $-0/+2,0$	9,0
180	184	264	40,0	1,5	40,0	8	38,1	38,4 $\pm 3,0$	9,0
200	204	284	40,0	1,5	40,0	8	38,1	38,4 $\pm 3,0$	9,0

Pacifyre® AWM II / Pacifyre® AWM III

Design of the pipe collar in the size Pacifyre® AWM II

Annex 3

English translation prepared by DIBt

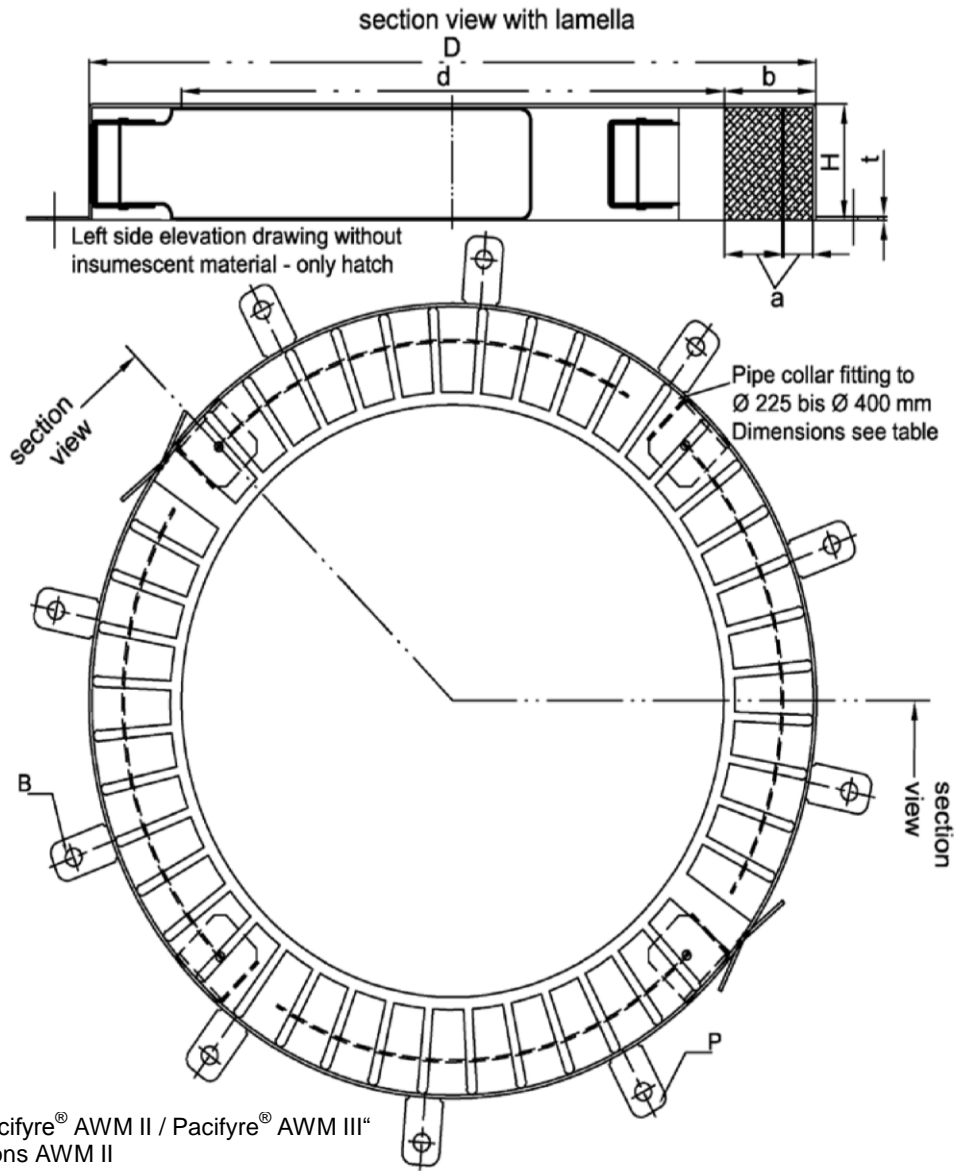

dA [mm]	d [mm]	D [mm]	b [mm]	t [mm]	H [mm]	P [Stck]	h [mm]	a [mm]	B [mm]
225	239	328	44,5	1,5 / 1,0	51,5	10	50	42,0 ± 3,0	8,0
250	264	353	44,5	1,5 / 1,0	51,5	10	50	42,0 ± 3,0	8,0
280	289	378	44,5	1,5 / 1,0	51,5	12	50	42,0 ± 3,0	8,0
300	314	403	44,5	1,5 / 1,0	51,5	12	50	42,0 ± 3,0	8,0
315	328	417	44,5	1,5 / 1,0	51,5	12	50	42,0 ± 3,0	8,0
355	370	459	44,5	1,5 / 1,0	51,5	12	50	42,0 ± 3,0	8,0
400	415	504	44,5	1,5 / 1,0	51,5	12	50	42,0 ± 3,0	8,0

Pacifyre® AWM II / Pacifyre® AWM III

Design of the pipe collar in the size Pacifyre® AWM II

Annex 4

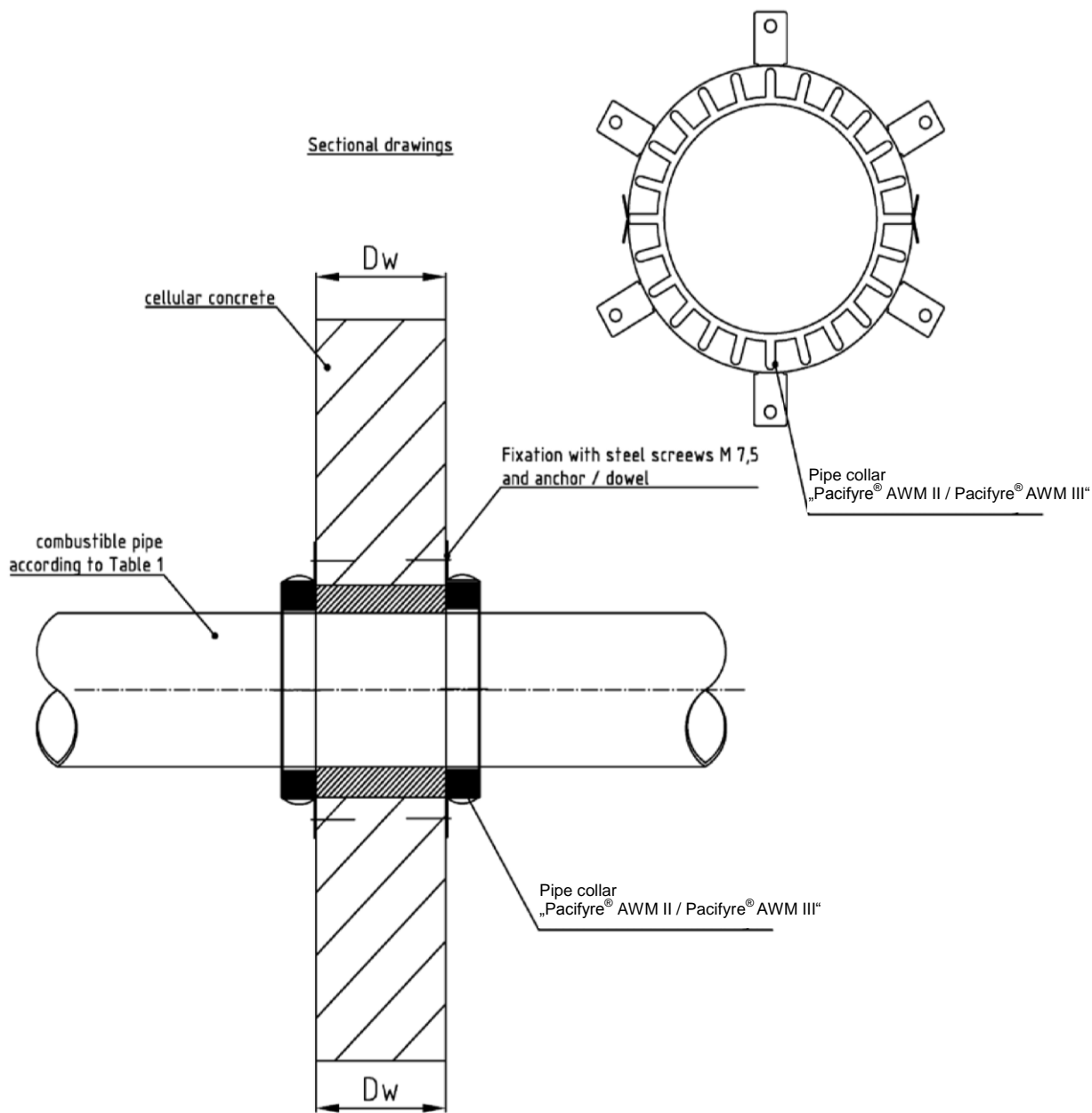

Table 1

Type of pipe	Ø [mm]	s [mm]	Pipe collar size	ρ Wand	D_w [mm]	Classification
PVC	200	9,6	AWM II 200	550 kg/m ³	100	EI 240-U/C

Pacifyre® AWM II / Pacifyre® AWM III

Example for a pipe sealing of fire resistance class EI 240-U/C, using pipe collar "Pacifyre® AWM II / Pacifyre® AWM III", in the size Pacifyre® AWM II, ø 200

Annex 5

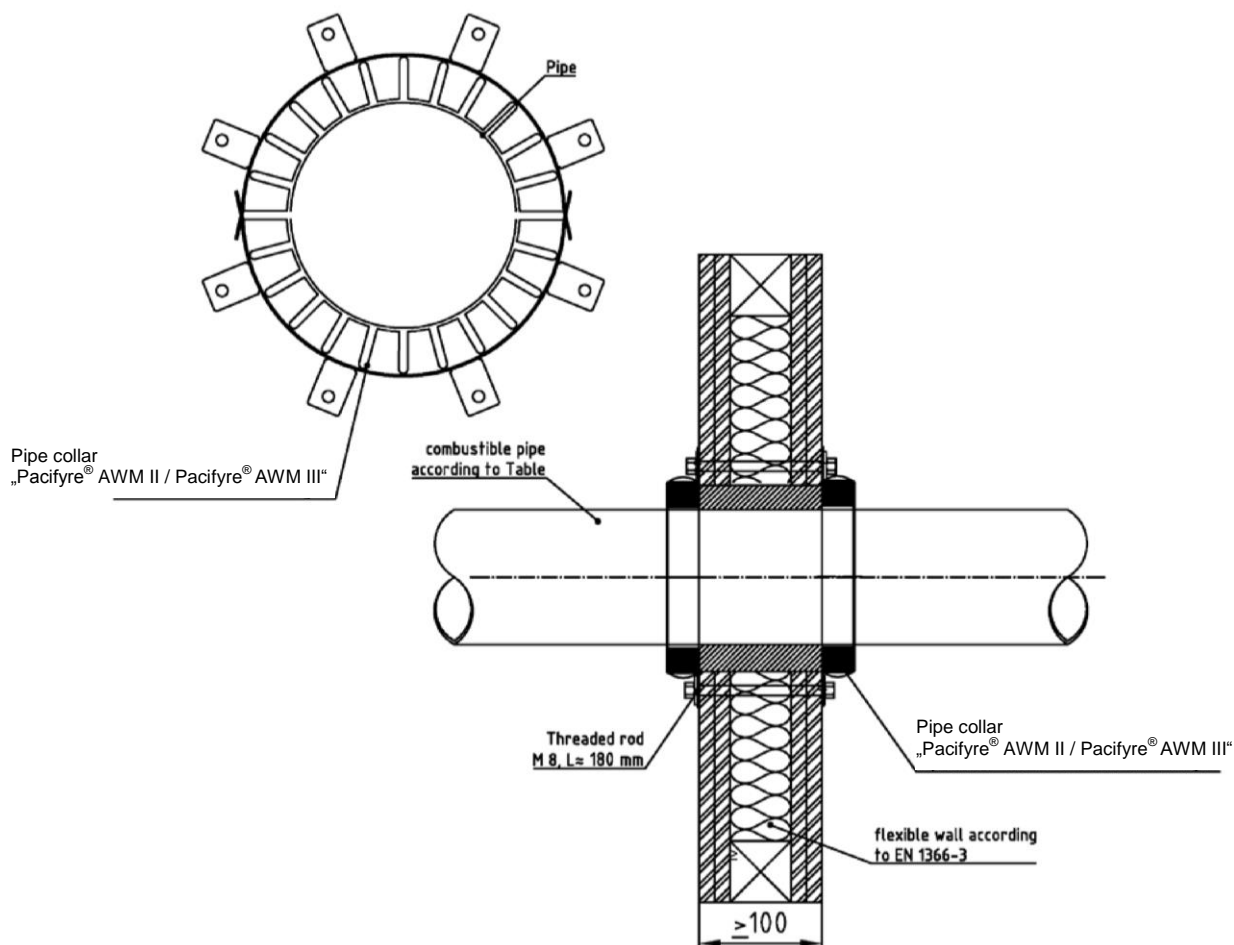

Flexible wall
 CW 50x50x0,6 u. UW 50x40x0,6 according to DIN 18182-01
 2 x 12,5 mm gypsum board F / EN 520-G25/2,5 according to EN 520 two layers on both sides
 40 mm mineral wool insulation, ρ 100kg/m³, melting point \geq 1000° C, A1 according to EN 13501-1

Pipe			
Type of pipe	\varnothing [mm]	s [mm]	Pipe collar size
Coolfit	180	/	AWM II 180

electronic copy of the eta by dibt: eta-13/0906

Pacifyre® AWM II / Pacifyre® AWM III

Example for a pipe sealing of fire resistance class EI 120-U/C, using pipe collar "Pacifyre® AWM II / Pacifyre® AWM III", in the size Pacifyre® AWM II, \varnothing 180

Annex 6

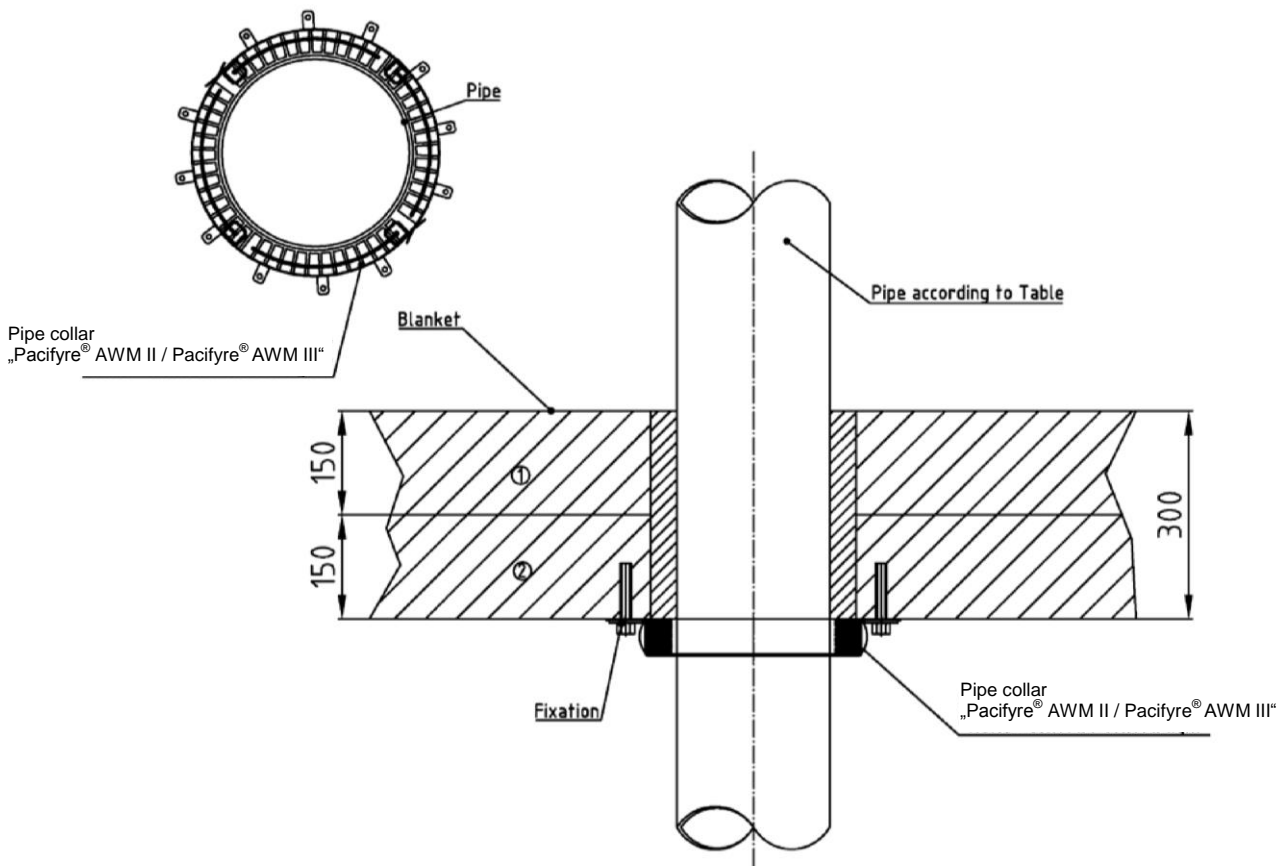

Blanket

- 1 Aerated concrete blocks d = 150 mm; 600 - 650 kg/m³
- 2 Aerated concrete panels d = 150 mm; 450 - 500 kg/m³

Pipe			
Type of pipe	Ø [mm]	s [mm]	Pipe collar size
PVC	400	11,7	AWM II 400

Fixation:

- Screws MMS-P 7,5 x 45
- and
- metal multipurpose anchors 8 x 38

electronic copy of the eta by dibt: eta-13/0906

Pacifyre® AWM II / Pacifyre® AWM III

Example for a pipe sealing of fire resistance class EI 180-U/C or E240-U/C, using pipe collar "Pacifyre® AWM II / Pacifyre® AWM III", in the size Pacifyre® AWM II, ø 400

Annex 7

English translation prepared by DIBt

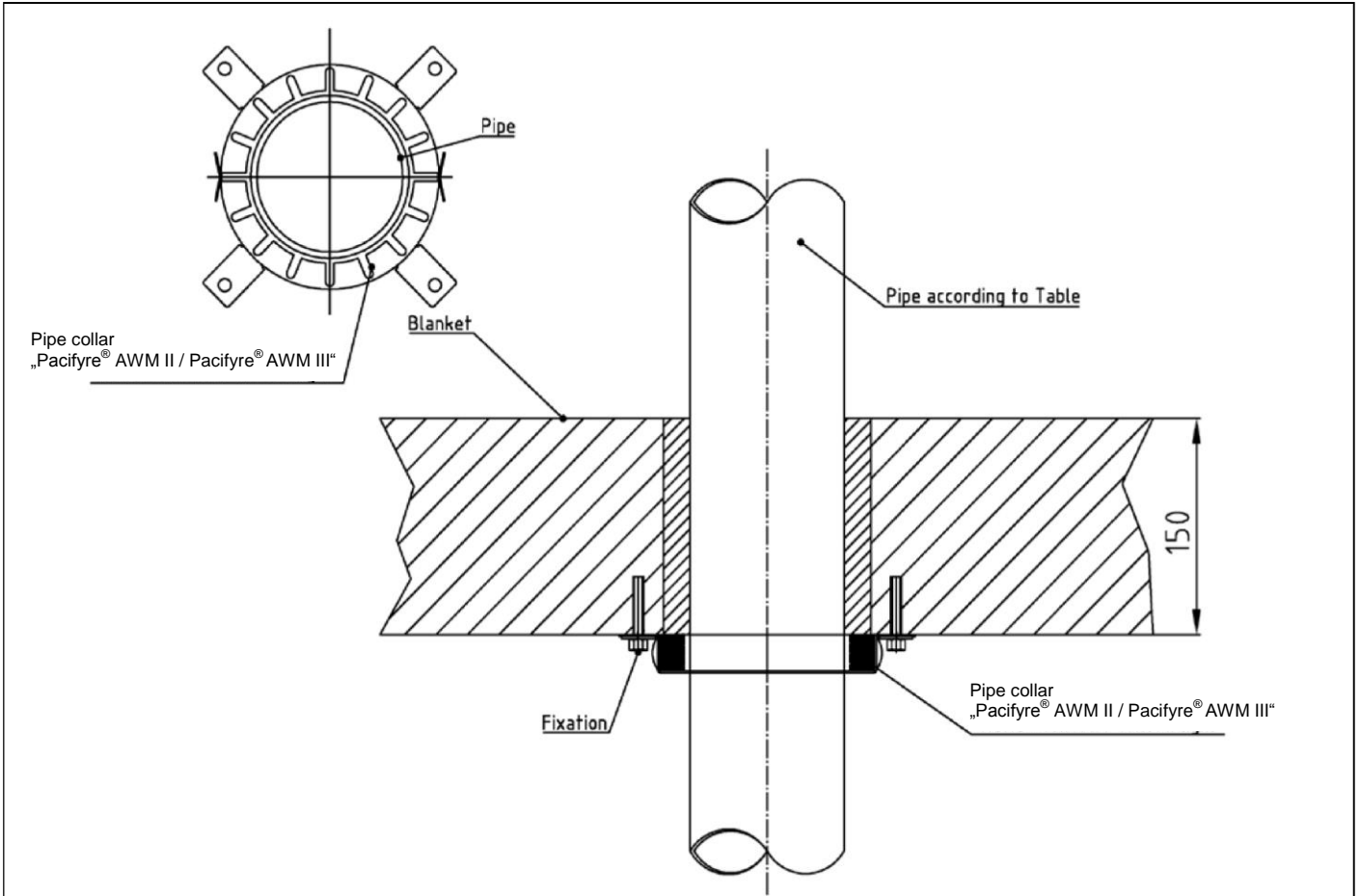

Blanket
Aerated concrete according to EN 1366-3

Pipe			
Type of pipe	∅ [mm]	s [mm]	Pipe collar size
PP	110	2,7	AWM III 110

Fixation:
Screws MMS-P 7,5 x 45
and
metal multipurpose anchors 8 x 38

electronic copy of the eta by dibt: eta-13/0906

Pacifyre® AWM II / Pacifyre® AWM III

Example for a pipe sealing of fire resistance class EI 120-U/U, using pipe collar "Pacifyre® AWM II / Pacifyre® AWM III", in the size Pacifyre® AWM III, ∅ 110

Annex 8