

Approval body for construction products
and types of construction

Bautechnisches Prüfamt

An institution established by the Federal and
Laender Governments



European Technical Assessment

ETA-13/0232
of 16 May 2018

English translation prepared by DIBt - Original version in German language

General Part

Technical Assessment Body issuing the
European Technical Assessment:

Deutsches Institut für Bautechnik

Trade name of the construction product

Nosing expansion joint "MAURER XW1 Expansion Joint"

Product family
to which the construction product belongs

Nosing expansion joint for road bridges

Manufacturer

MAURER SE
Frankfurter Ring 193
80807 München
DEUTSCHLAND

Manufacturing plant

Werk 1
Werk 2
Werk 3
Werk 4

This European Technical Assessment
contains

11 pages including 6 annexes which form an integral part
of this assessment

This European Technical Assessment is
issued in accordance with Regulation (EU)
No 305/2011, on the basis of

ETAG 032 Part 4: "Nosing Expansion Joints",
used as EAD according to Article 66 Paragraph 3 of
Regulation (EU) No 305/2011.

This version replaces

ETA-13/0232 issued on 28 May 2013

The European Technical Assessment is issued by the Technical Assessment Body in its official language. Translations of this European Technical Assessment in other languages shall fully correspond to the original issued document and shall be identified as such.

Communication of this European Technical Assessment, including transmission by electronic means, shall be in full. However, partial reproduction may only be made with the written consent of the issuing Technical Assessment Body. Any partial reproduction shall be identified as such.

This European Technical Assessment may be withdrawn by the issuing Technical Assessment Body, in particular pursuant to information by the Commission in accordance with Article 25(3) of Regulation (EU) No 305/2011.

Specific part

1 Technical description of the product

The nosing expansion joint for road bridges "MAURER XW 1 Expansion Joint" is a kit, which consists of the following components:

- round steel bar stirrups Ø20, S235 JR for anchoring in concrete (only for concrete bridges)
- Anchorage made of steel anchor plates 100x200x15 mm, S235JR (only for concrete bridges)
- Steel T-profile T 320x20 with one waved edge, steel grade S235J2 (only for concrete bridges) or a steel angle profile L 150x20, steel grade S355J2 with a waved edge welded with a flange FL 120x15, steel grade S235JR (for concrete and steel bridges)
- Steel edge profile to hold the sealing element, steel grade S235J0¹ or S235J0 in combination with 1.4571 (hybrid profile) (for concrete and steel bridges)
- Five corrosion protection systems acc. to EN ISO 12944-2² are alternatively parts of the kit. The systems are laid down in Manufacturers the technical documents³. The choice depends on national regulations.
- Flexible elastomeric sealing element made of EPDM (replaceable) (for concrete and steel bridges)

The substructure (concrete in recess and starter bars) and the connection to the bridge deck waterproofing are not part of the kit.

Annex 1 shows the system built-up and the performances. The components and characteristics are specified in Annex 2 to 5.

2 Specification of the intended use in accordance with the applicable European Assessment Document

The expansion joint is used to ensure the continuity of the running surface as well as bearing capacity and the movement of the bridges whatever the nature of the structure constitutive material. The product is used for the user categories vehicles, cyclists and pedestrians for an operating temperature from -40 °C to +45 °C.

The kit is intended to use for bridges made from steel or concrete.

The performances given in Section 3 are only valid if the expansion joint is used in compliance with the specifications and conditions given in Annex B.

In addition the manufacturer gives in the technical documentation information about the conditions of the bridge for the installation of the expansions joints.

The verifications and assessment methods on which this European Technical Assessment is based lead to an assumed working life of the expansion joint of at least 50 years. The sealing element is replaceable and is verified for an assumed working life of 25 years.

The indications given on the working life cannot be interpreted as a guarantee given by the producer, but are to be regarded only as a means for choosing the right products in relation to the expected economically reasonable working life of the works.

¹ EN 10025-2 Hot rolled products of structural steels - Part 2: Technical delivery conditions for non-alloy structural steels

² EN ISO 12944-2 Paints and varnishes – Corrosion protection of steel structures by protective paint systems – Part 2: Classification of environments

³ The manufacturer's technical documents comprises all information necessary for the production and the installation of the product as well as for repair of expansion joint and it is deposited with DIBt.

3 Performance of the product and references to the methods used for its assessment

3.1 Mechanical resistance and stability (BWR 1)

Essential characteristic	Performance
Mechanical resistance	Annex A1 and A5
Resistance to fatigue	Annex A1 and A2
Seismic behaviour	No performance assessed
Movement capacity	Annex A1, A3 and A4
Cleanability	Annex A1
Resistance to wear	Not relevant
Watertightness	Annex A1

3.2 Hygiene, health and the environment (BWR 3) ¹

Essential characteristic	Performance
Content, release of dangerous substances	No performance assessed

3.3 Safety and accessibility in use (BWR 4)

Essential characteristic	Performance
Ability to bridge gaps and levels in the running surface: <ul style="list-style-type: none"> – Allowable surface gaps and voids – Level differences in the running surface 	Annex A1, A3 and A4
Skid resistance	Not relevant
Drainage capacity	Not relevant

4 Assessment and verification of constancy of performance (AVCP) system applied, with reference to its legal base

In accordance with European Technical Guideline ETAG No. 032 the applicable European legal act is 2001/19/EC.

The system to be applied is: 1

5 Technical details necessary for the implementation of the AVCP system, as provided for in the applicable EAD

Technical details necessary for the implementation of the AVCP system are laid down in the control plan deposited with Deutsches Institut für Bautechnik.

Issued in Berlin on 16 May 2018 by Deutsches Institut für Bautechnik

BD Dipl.-Ing. Andreas Kummerow
Head of Department

beglaubigt:
Hemme

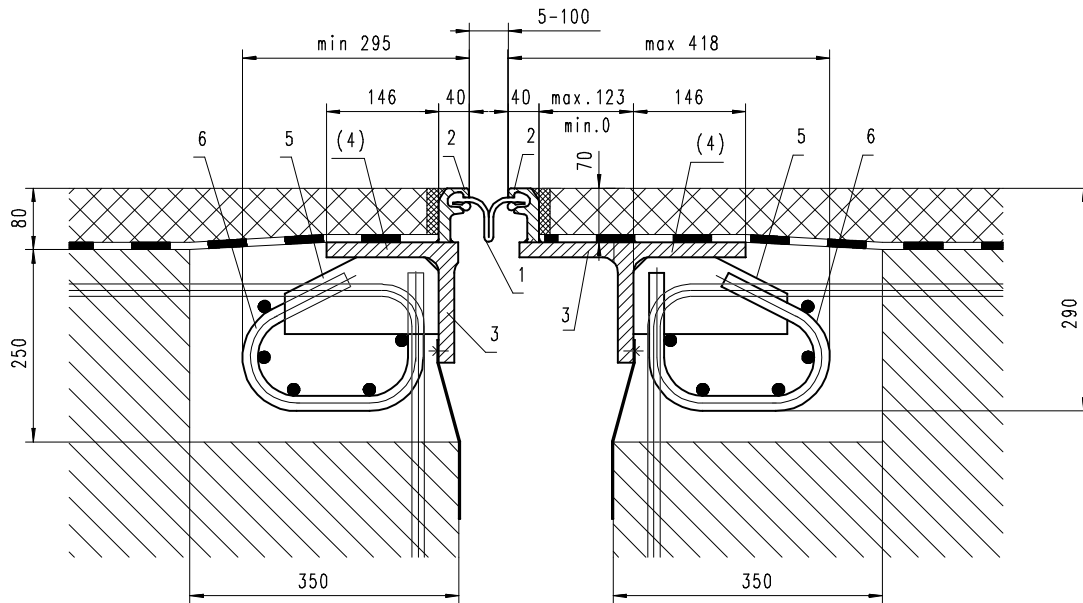

- 1 Flexible elastomeric sealing element made of EPDM (replaceable) (for concrete and steel bridges)
- 2 Steel edge profile to hold the sealing element, steel grade S235J0 or S235J0 in combination with 1.4571 (hybrid profile) (for concrete and steel bridges)
- 3 Steel T-profile T 320x20 with one waved edge, steel grade S235J2 (for concrete and steel bridges)
- 4 or (instead of 3) a steel angle profile L 120x20, steel grade S355J2 with a waved edge welded with a flange FL 120x15, steel grade S235JR (for concrete and steel bridges)
- 5 Anchorage made of steel anchor plates 100x200x15 mm, S235JR (only for concrete bridges)
- 6 round steel bar stirrups $\varnothing 20$, S235 JR for anchoring in concrete (only for concrete bridges)

The positions 2 to 6 are welded together.

User categories	vehicles, cyclists, pedestrian
Slope in traffic direction	$\leq 9\%$
Slope in direction of the expansion joint	$\leq 10\%$
Operating temperatures	$-40\text{ °C} \leq T \leq +45\text{ °C}$
Working life	main components: 50 years replaceable components: 25 years
Mechanical resistance	pass
Resistance to fatigue	pass
Seismic behaviour	no performance assessed
Movement capacity (movement direction)	max. $u_{max} = 95\text{ mm}$
Minimum opening	min $e_{x,min} = 5\text{ mm}$
Vertical movement capacity	$u_z = 20\text{ mm}$
Cleanability	pass
Resistance to wear	not relevant
Watertightness	watertight
Release of dangerous substance	no performance assessed
Allowable gaps and voids	pass for $45^\circ \leq \beta \leq 135^\circ$
Level differences in the running surface	pass
Skid resistance	not relevant
Drainage Capacity	not relevant

Nosing expansion joint "MAURER XW1 Expansion Joint"
MAURER SE

System built up and classifications

Annex A1

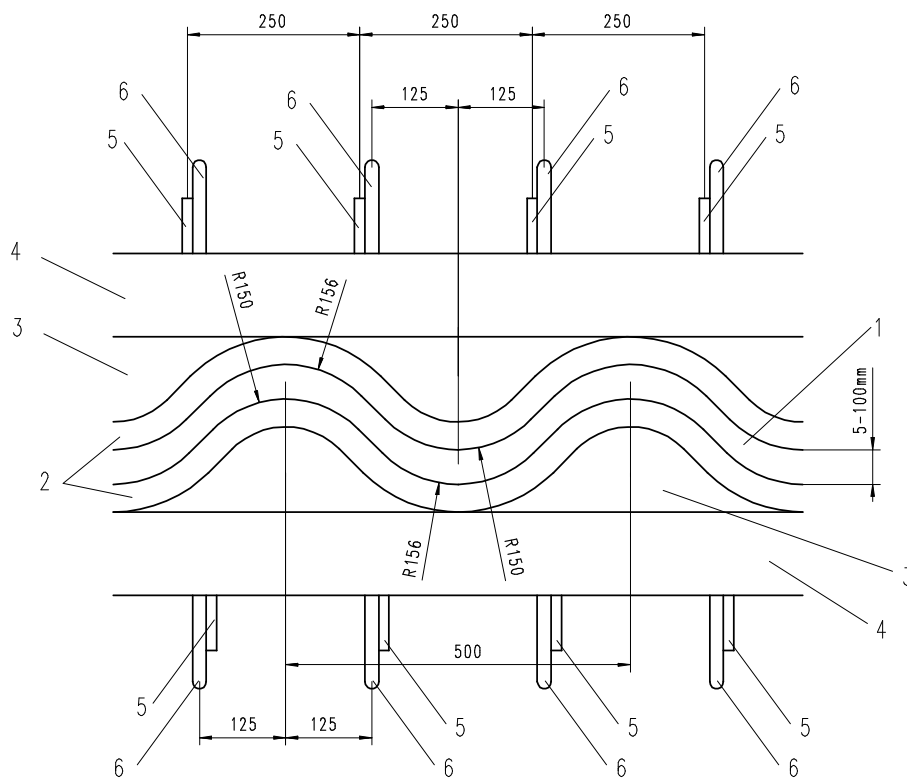

Top view of XW 1

Working life:

According to EN 1991-2 the assumed working life depends on traffic categories. For the expansion joint XW1 the following is valid:

For the modified load model FLM1 the constant amplitude fatigue limit has been verified. Therefore the requirement for an assumed working life of 50 years with $N_{obs} = 2.5 \times 10^7$ (Number of lorries) is included.

electronic copy of the eta by dibt: eta-13/0232

Nosing expansion joint "MAURER XW1 Expansion Joint"
MAURER SE

Top view and working life

Annex A2

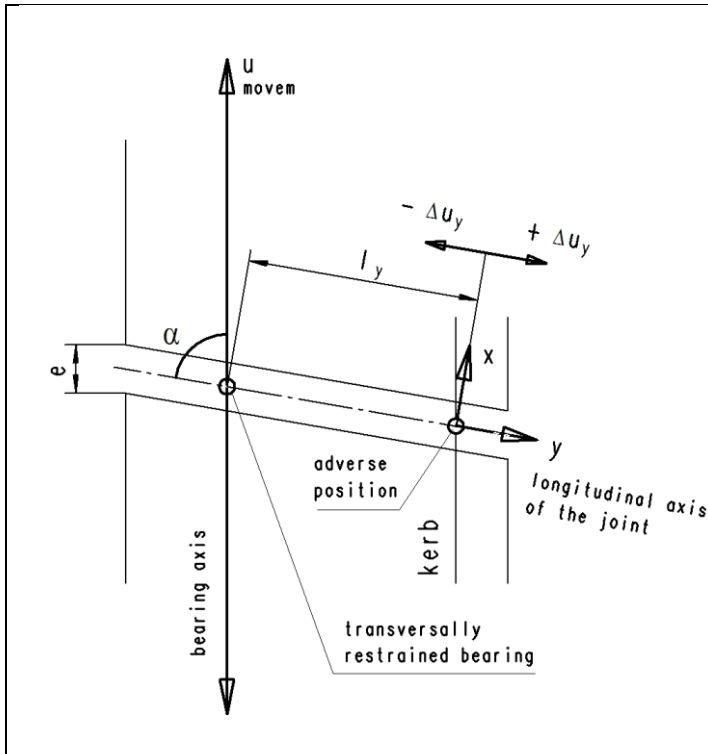

u movement capacity in movement direction of the transversally restrained bearing with the movement related to transversal, longitudinal and vertical axis of the expansion joint u_x, u_y, u

Δu_y additional movement in direction of the longitudinal axis of the joint at the adverse position

e gap width of the expansion joint in movement direction

$e_{x,min}$ minimum gap width perpendicular to the edge of the joint of the expansion joint

α angle between bridge movement direction and longitudinal joint axis

L_q length of the expansion joint in longitudinal joint axis resp. distance between transversally restrained bearing axis and the adverse position

Movement capacity:

intermediate values may be calculated by linear interpolation

α [°]	u_{max} [mm]	$e_{x,min}$ [mm]	$u_{z,max}$ [mm]
90±24	95	5	20
±65	95 (90*)	5	
±60	92,5 (65*)	7.5	
±55	90 (75*)	10	
±50	90	10	
±45	85	15	

* if passing over by cyclist is intended

The XW1 expansion joint has to be designed to allow additional displacements Δu_y in longitudinal axis of the joint, which are caused by creep, shrinkage or temperature.

Values for Δu_y are given in Annex 4.

electronic copy of the eta by dibt: eta-13/0232

Nosing expansion joint "MAURER XW1 Expansion Joint"
MAURER SE

Movement Capacity

Annex A3

English translation prepared by DIBt

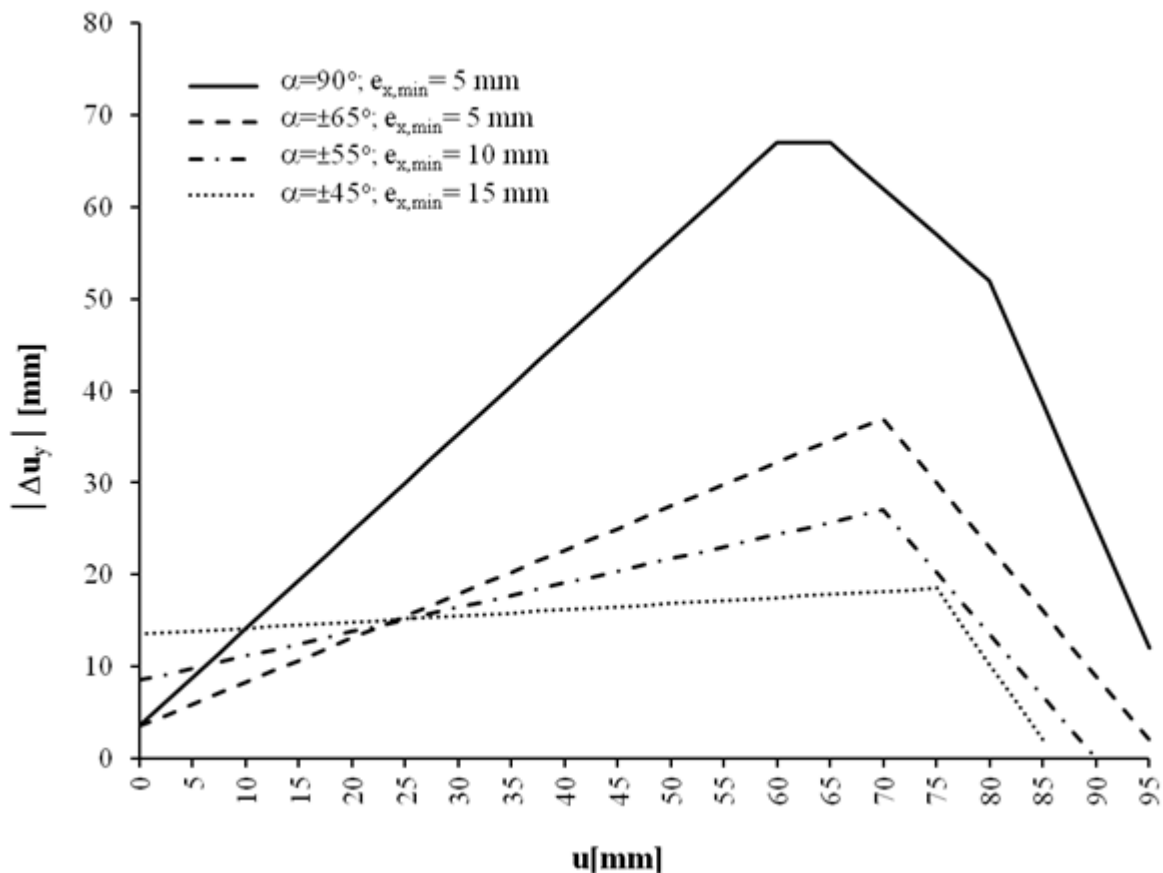

The additional movement capacity Δu in longitudinal direction depends on maximum required movement capacity of the bridge (u), required minimum gap width perpendicular to the longitudinal axis of the joint ($e_{x,min}$) and on skew angle.

For cyclists are additional examinations necessary.

electronic copy of the eta by dibt: eta-13/0232

Nosing expansion joint "MAURER XW1 Expansion Joint"
MAURER SE

Additional movement capacity Δu for vehicles

Annex A4

Concrete

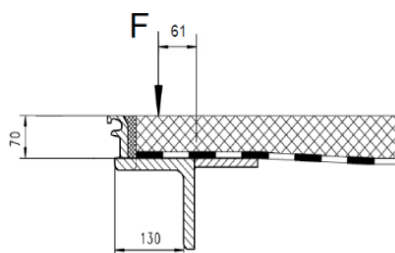

Anchorage forces in the round steel bar stirrups:

ULS	FAT
force/anchor	force/anchor
$Z_d = 20,3 \text{ kN}$	$\Delta Z_d = 15,8 \text{ kN}$
$D_d = 39,1 \text{ kN}$	$\Delta D_d = 26,0 \text{ kN}$

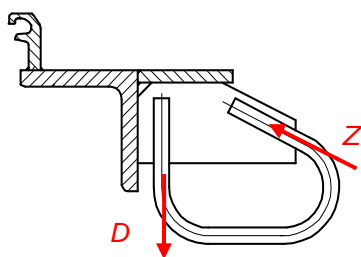

Distance between the anchor: $a = 250 \text{ mm}$

Steel

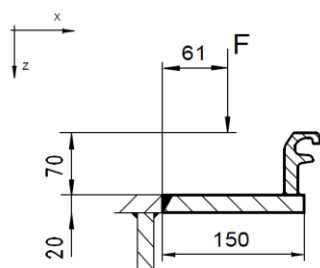

Resulting actions for the design of a connection to a steel bridge

ULS	FAT
$F_{x,d} = 9,6 \text{ kN}$	$\Delta F_{x,d} = 10,4 \text{ kN}$
$F_{y,d} = 5,5 \text{ kN}$	$\Delta F_{y,d} = 0 \text{ kN}$
$F_{z,d} = 55 \text{ kN}$	$\Delta F_{z,d} = 28,5 \text{ kN}$

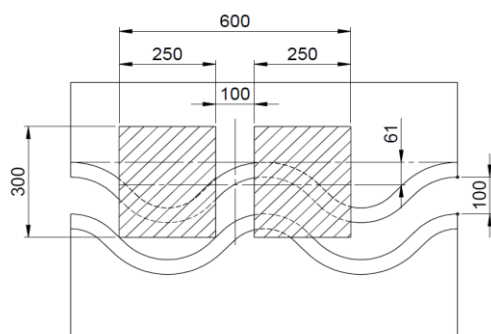

The forces are only for one of the twin tyre with $b = 250 \text{ mm}$.

For the design of the connection to the bridge the double load on a length of $b = 600 \text{ mm}$ and a arm of $d = 61 \text{ mm}$ shall be to consider.

Installation

The performances of the expansion joint can be assumed only, if the installation is carried out according to the installation instructions stated in the manufacturers technical documentation by the manufacturer, in particular taking account of the following points:

- installation by appropriately trained personnel,
- installation of only those components which are marked components of the kit,
- installation with the required tools and adjuvant,
- precautions during installation,
- Inspection of the local bounding conditions,
- inspecting of the bridge deck connection and the correct preparation,
- inspecting compliance with suitable weather conditions,
- inspection during installation and of the finished product and documentation of the results.

Nosing expansion joint "MAURER XW1 Expansion Joint"

Intended use
Specifications

Annex B