

Approval body for construction products
and types of construction

Bautechnisches Prüfamt

An institution established by the Federal and
Laender Governments



European Technical Assessment

ETA-13/0845
of 22 June 2018

English translation prepared by DIBt - Original version in German language

General Part

Technical Assessment Body issuing the
European Technical Assessment:

Deutsches Institut für Bautechnik

Trade name of the construction product

Insulation support KOELNER TFIX-8P

Product family
to which the construction product belongs

Nailed-in plastic anchor for fixing of external thermal
insulation composite systems with rendering in concrete
and masonry

Manufacturer

RAWLPLUG S.A.
Kwidzynska 6
51-416 WROCLAW
POLEN

Manufacturing plant

Production plant No. 2

This European Technical Assessment
contains

12 pages including 3 annexes which form an integral part
of this assessment

This European Technical Assessment is
issued in accordance with Regulation (EU)
No 305/2011, on the basis of

EAD 330196-01-0604

The European Technical Assessment is issued by the Technical Assessment Body in its official language. Translations of this European Technical Assessment in other languages shall fully correspond to the original issued document and shall be identified as such.

Communication of this European Technical Assessment, including transmission by electronic means, shall be in full. However, partial reproduction may only be made with the written consent of the issuing Technical Assessment Body. Any partial reproduction shall be identified as such.

This European Technical Assessment may be withdrawn by the issuing Technical Assessment Body, in particular pursuant to information by the Commission in accordance with Article 25(3) of Regulation (EU) No 305/2011.

Specific Part

1 Technical description of the product

The KOELNER insulation support TFIX-8P is a nailed-in anchor which consists of a plastic part made of polypropylene (virgin material) and an accompanying specific nail of glass fibre reinforced polyamide (virgin material).

The anchor may in addition be combined with the anchor plates KWL 90, KWL 110 and KWL 140.

The product description is given in Annex A.

2 Specification of the intended use in accordance with the applicable European Assessment Document

The performances given in Section 3 are only valid if the anchor is used in compliance with the specifications and conditions given in Annex B.

The verification and assessment methods on which this European Technical Assessment is based lead to the assumption of a working life of the anchor of at least 25 years. The indications given on the working life cannot be interpreted as a guarantee given by the producer, but are to be regarded only as a means for choosing the right products in relation to the expected economically reasonable working life of the works.

3 Performance of the product and references to the methods used for its assessment

3.1 Safety and accessibility in use (BWR 4)

Essential characteristic	Performance
Characteristic tension resistance	See Annex C 1
Edge distances and spacing	See Annex B 2
Point thermal transmittance	See Annex C 2
Displacements	See Annex C 2

3.2 Energy economy and heat retention (BWR 6)

Essential characteristic	Performance
Point thermal transmittance	See Annex C 2

4 Assessment and verification of constancy of performance (AVCP) system applied, with reference to its legal base

In accordance with EAD No. 330196-01-0604, the applicable European legal act is: [97/463/EC].

The system to be applied is: 2+

English translation prepared by DIBt

5 Technical details necessary for the implementation of the AVCP system, as provided for in the applicable EAD

Technical details necessary for the implementation of the AVCP system are laid down in the control plan deposited with Deutsches Institut für Bautechnik.

Issued in Berlin on 22 June 2018 by Deutsches Institut für Bautechnik

BD Dipl.-Ing. Andreas Kummerow
Head of Department

beglaubigt:
E. Aksünger

Installed anchor insulation support KOELNER TFIX 8P

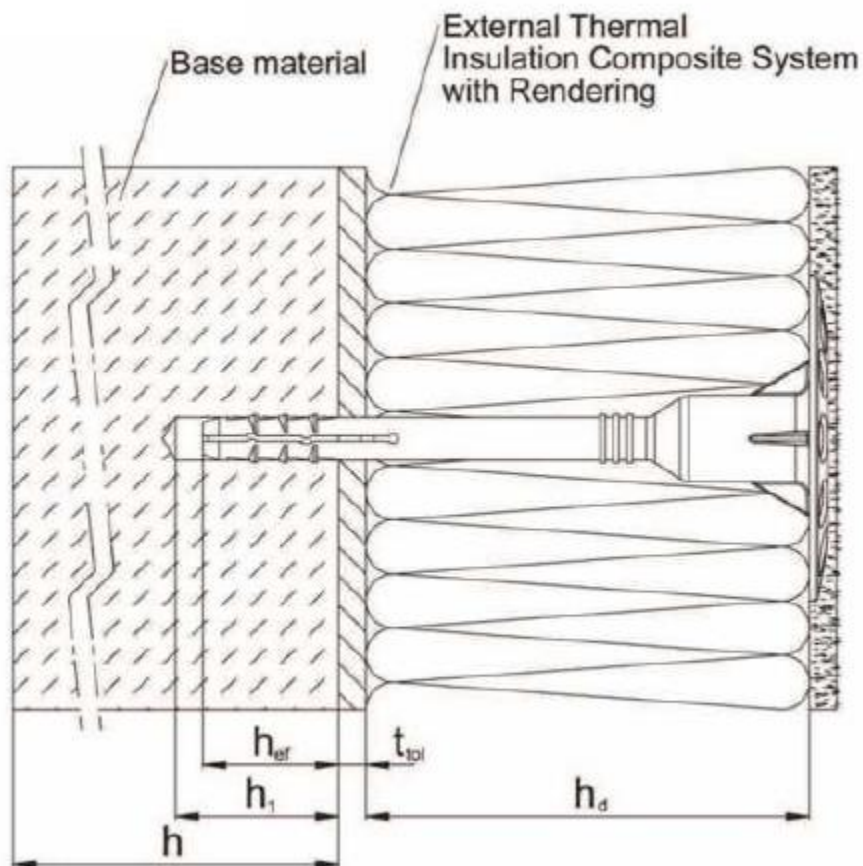

Fixing of ETICS in concrete and masonry

Legend

- h_{ef} = effective anchorage depth
- h = thickness of member (wall)
- h_1 = depth of drilled hole to deepest point
- h_d = thickness of insulation material
- t_{tol} = thickness of equalizing layer or non-load-bearing coating

Insulation support KOELNER TFIX-8P

Product description
Installed anchor

Annex A1

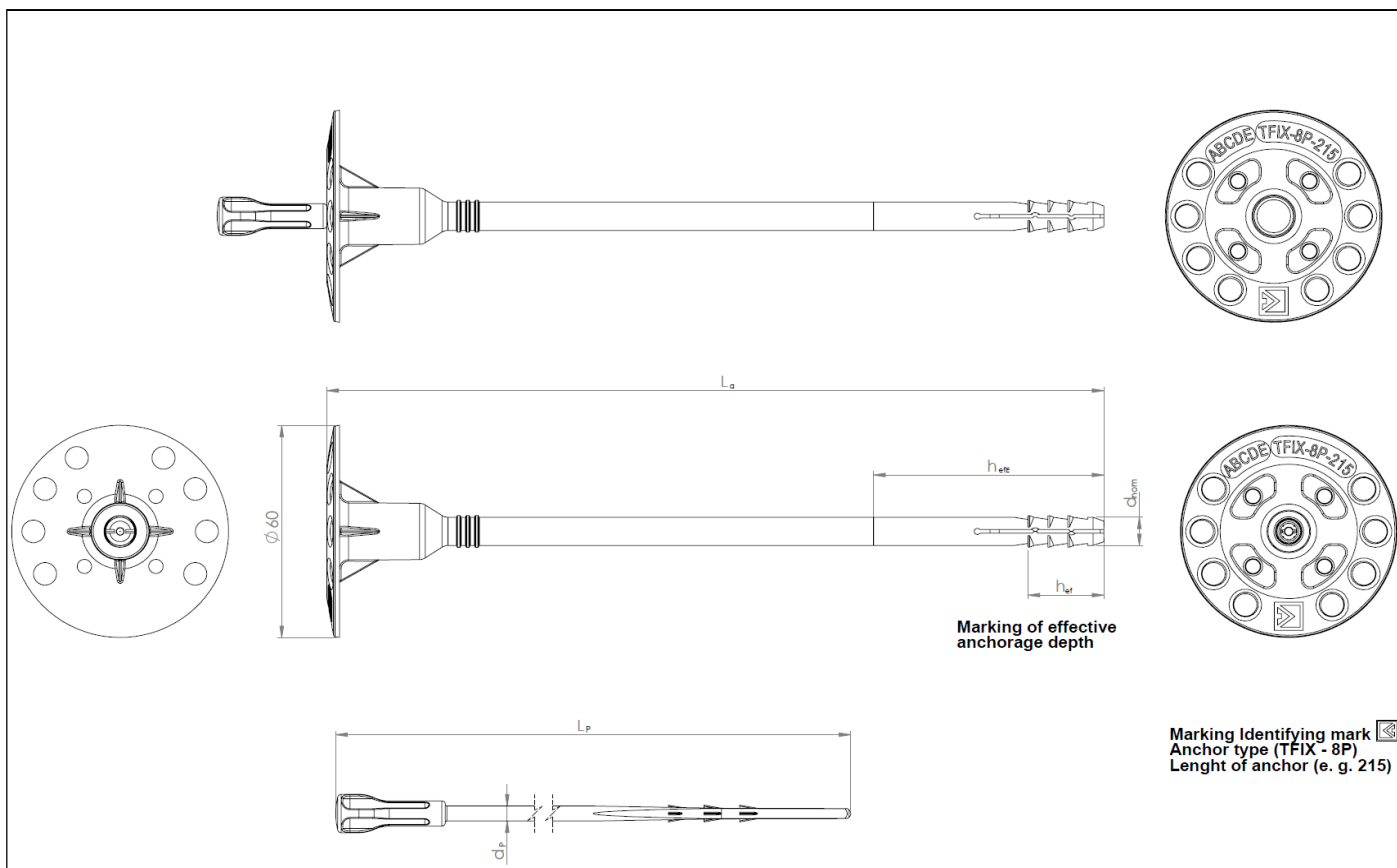

Table A.1: Dimensions

Anchor sleeve			Accompanying expansion pin
d _{nom} [mm]	Base material		d _p [mm]
	ABCD	E	
8	h _{ef} [mm] 25	h _{efE} [mm] 65	4.35 _{±0,1}

Various lengths of the anchor are possible:
Determination of max thickness of insulation:

$$L_{a \min} = 115\text{mm}; L_{a \max} = 215\text{mm}$$

$$h_d = L_a - t_{\text{tol}} - h_{\text{ef}} \quad \text{z.B. } L_a = 135\text{mm}$$

$$t_{\text{tol}} = 10\text{mm}$$

$$h_d = 135\text{mm} - 10\text{mm} - 25\text{mm}$$

$$h_d = 100\text{mm}$$

Table A.2: Materials

designation	Material
Anchor sleeve	Polypropylen (virgin material)
Expansion pin	Polyamide, Glass Fiber reinforced (virgin material)

Insulation support KOELNER TFIX-8P	Annex A2
Product description Dimensions and materials	

KWL 140

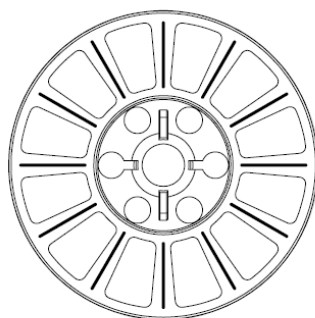

KWL 110

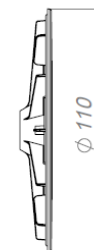
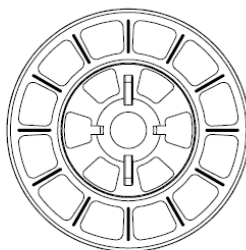

KWL 090

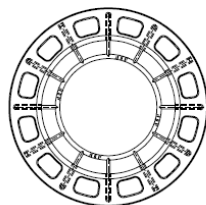

Table A.3: Additional plates, diameter and material

Plate	Diameter	Colour	Materials
KWL 90	90	nature	PA6 + GF, PP
KWL 110	110	nature	
KWL 140	140	nature	

Insulation support KOELNER TFIX-8P

Product description
Additional plate

Annex A3

Specifications

Anchorage subject to:

- The anchor may only be used for transmission of wind suction loads and shall not be used for the transmission of dead loads of the external thermal insulation composite system (ETICS).

Base materials:

- Normal weight concrete (use category A), according to Annex C1.
- Solid masonry (use category B), according to Annex C1.
- Hollow or perforated masonry (use category C), according to Annex C1.
- Lightweight aggregate concrete (use category D), according to Annex C1.
- Autoclaved aerated concrete (use category E), according to Annex C1.
- For other base materials of the use categories A, B, C, D and E the characteristic resistance of the anchor may be determined by job site tests acc. to EOTA Technical Report TR 051 Edition December 2016.

Temperature Range:

- 0°C to +40°C (max. short term temperature +40°C and max. long term temperature +24°C).

Design:

- The anchorages are designed under the responsibility of an engineer experienced in anchorages and masonry work with the partial safety factors $\gamma_M = 2,0$ and $\gamma_F = 1,5$ in absence of other national regulations.
- Verifiable calculation notes and drawings are prepared taking account of the loads to be anchored. The position of the anchors is indicated on the design drawings.
- Fasteners are only to be used for multiple fixings of ETICS.

Installation:

- Hole drilling by the drill modes according to Annex C1.
- Anchor installation carried out by appropriately qualified personnel and under the supervision of the person responsible for technical matters on the site.
- Installation temperature from 0°C to +40°C
- Exposure to UV due to solar radiation of the anchor not protected by rendering ≤ 6 weeks.

Insulation support KOELNER TFIX-8P

Intended use
Specifications

Annex B1

Table B.1: Installation parameters

			[mm]
Drill hole diameter		$d_0 =$	8
cutting diameter of drill bit		$d_{cut} <$	8,45
Base material	ABCD	depth of drilled hole to deepest point	$h_1 >$ 40
		effective anchorage depth	$h_{ef} \geq$ 25
	E	depth of drilled hole to deepest point	$h_1 >$ 80
		effective anchorage depth	$h_{ef} \geq$ 65

Table B.2: Anchor distances and dimensions of members

Use category		ABCD	E
Minimum spacing	$s_{min} =$ [mm]	100	100
Minimum edge distance	$c_{min} =$ [mm]	100	100
Minimum thickness of member	$h =$ [mm]	100	110

Scheme of distances and spacing

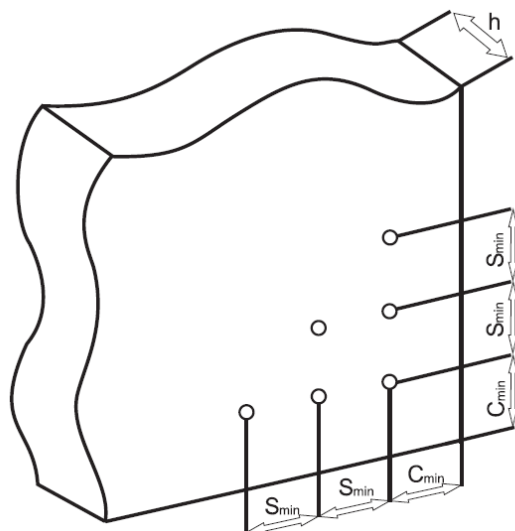

Insulation support KOELNER TFIX-8P

Intended use
Installation parameters and minimum distances

Annex B2

Installation instructions

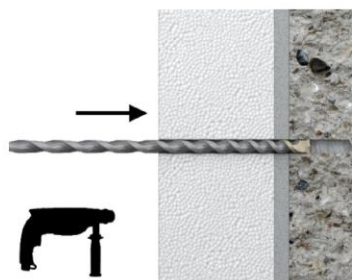

Drill a hole of required diameter and depth.

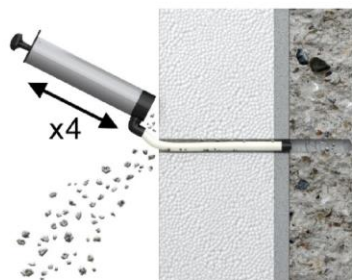

Blow out dust at least 4 times with a hand pump.

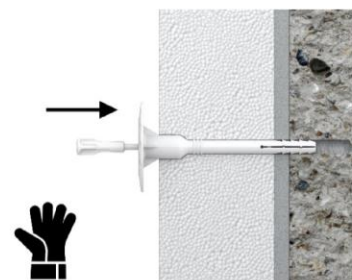

Insert TFIX-8P into the wellbore (this product should be pushed into the wellbore).

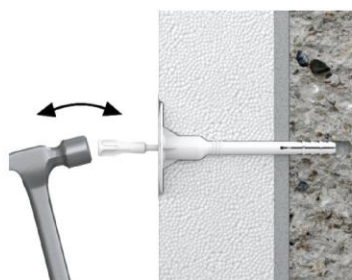

Lightly tap the plastic nail into the plastic sleeve until fixing is secure and flush with insulation material. Use the hammer for proper installation.

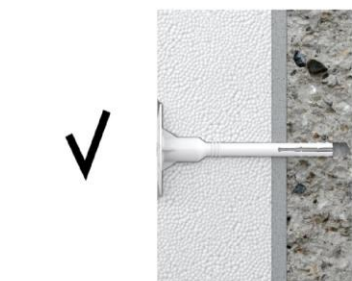

After installation.

electronic copy of the eta by dibt: eta-13/0845

Insulation support KOELNER TFIX-8P

Intended use
Installation instructions

Annex B3

Table C.1: Characteristic resistance to tension loads N_{Rk} in concrete and masonry for a single anchor [kN]

Base material	Bulk density class ρ [kg/dm ³]	Minimum compr.strength f_b [N/mm ²]	General remarks	Drilling method (2)	N_{Rk} [kN]
Concrete C12/15 In accordance with EN 206-1:2000		≥ 15	-	H	0,4
Concrete C16/20 - C50/60 In accordance with EN 206-1:2000		≥ 20	-	H	0,5
Clay brick Mz, In accordance with EN 771-1:2011	$\geq 1,8$	≥ 12	Vertically perforation up to 15%	H	0,5
Sand-lime solid bricks (calcium silicate) KS, In accordance with EN 771-2:2011	$\geq 1,8$	≥ 12	Vertically perforation up to 15%	H	0,5
Sand-lime solid bricks (calcium silicate) KSL, In accordance with EN 771-2:2011	$\geq 1,4$	≥ 12	Vertically perforation up to 15%, with outer web thickness of ≥ 20 mm	H	0,3
Perforated clay bricks In accordance with EN 771-1:2011	$\geq 1,0$	≥ 12	Vertically perforation more than 15%, and less than 50% (1)	D	0,3
Lightweight concrete solid block, Vbl In accordance with EN 771-3:2011	$\geq 0,7$	≥ 4	Proportion of handle hole to resting area up to 10%, Maximum size of handle hole: 110x45 mm	D	0,3
Lightweight concrete hollow block, Hbl, In accordance with EN 771-3:2011	$\geq 0,8$	≥ 2	The anchor shall be placed in a way that spreading part is anchored in the web of the brick; Thickness of outer web ≥ 50 mm;   a = 50 mm d = 175 mm a = 50 mm d = 240 oder 300 mm	D	0,3
Lightweight aggregate Concrete, LA6 In accordance with EN 1520:2011, EN 771-3:2011	$\geq 1,0$	≥ 6	-	D	0,3
Autoclaved aerated concrete AAC 6, In accordance with EN 771-4:2011	$\geq 0,7$	≥ 6	-	D	0,5
(1) Thickness of outer web ≥ 12 mm (2) H = hammer drill, D= rotation drill					
Insulation support KOELNER TFIX-8P					
Performances Characteristic resistance				Annex C1	

Table C.2: Point thermal transmittance in accordance with EOTA Technical Report TR 025: 2016 – 05

Anchor type	Thickness of insulation material h_D [mm]	Point thermal transmittance χ [W/K]
KOELNER TFIX-8P	50 - 180	0,000

Table C.3: Plate stiffness in accordance with EOTA Technical Report TR 026: 2016 – 05

Anchor type	Diameter of the plate [mm]	Load resistance of the anchor plate [kN]	Plate stiffness [kN/mm]
KOELNER TFIX-8P	60	1,38	0,3

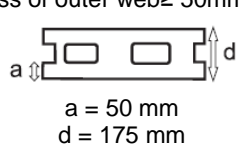
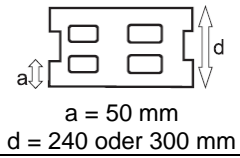
Table C.4: Displacements

Base material	Bulk density class ρ [kg/dm ³]	Minimum compr.strength f_b [N/mm ²]	Tension load N [kN]	Displacements $\delta_m(N)$ [mm]
Concrete C12/15 in accordance with EN 206-1:2000		15	0,13	0,5
Concrete C16/20 - C50/60 in accordance with EN 206-1:2000		20	0,17	0,5
Clay brick Mz, in accordance with EN 771-1:2011	$\geq 1,8$	12	0,13	0,3
Sand-lime solid bricks (calcium silicate) KS, in accordance with EN 771-2:2011	$\geq 1,8$	12	0,10	0,4
Sand-lime solid bricks (calcium silicate) KSL, in accordance with EN 771-2:2011	$\geq 1,4$	12	0,10	0,4
Perforated clay bricks in accordance with EN 771-1:2011	$\geq 1,0$	12	0,10	0,7
Lightweight concrete solid block, Vbl in accordance with EN 771-3:2011	$\geq 0,7$	4	0,13	1,1
Lightweight concrete hollow block, Hbl, in accordance with EN 771-3:2011	$\geq 0,8$	2	0,10	0,2
Lightweight aggregate Concrete, LA6 in accordance with EN 1520:2011, EN 771-3:2011	$\geq 1,0$	6	0,10	0,3
Autoclaved aerated concrete AAC 6, in accordance with EN 771-4:2011	$\geq 0,7$	6	0,17	0,3

Insulation support KOELNER TFIX-8P

Performances
Point thermal transmittance, plate stiffness, displacements

Annex C2