

Approval body for construction products  
and types of construction

Bautechnisches Prüfamt

An institution established by the Federal and  
Laender Governments



## European Technical Assessment

**ETA-18/0570**  
**of 21 November 2018**

English translation prepared by DIBt - Original version in German language

### General Part

Technical Assessment Body issuing the  
European Technical Assessment:

Deutsches Institut für Bautechnik

Trade name of the construction product

Hilti pipe clamps MP-L-I M8/M10

Product family  
to which the construction product belongs

Products related to installation systems supporting  
technical equipment for building services such as pipes,  
conduits, ducts and cables

Manufacturer

Hilti AG Liechtenstein  
Feldkircherstraße 100  
9494 Schaan  
FÜRSTENTUM LIECHTENSTEIN

Manufacturing plant

L1097347

This European Technical Assessment  
contains

11 pages including 7 annexes which form an integral part  
of this assessment

This European Technical Assessment is  
issued in accordance with Regulation (EU)  
No 305/2011, on the basis of

EAD 280016-00-0602

The European Technical Assessment is issued by the Technical Assessment Body in its official language. Translations of this European Technical Assessment in other languages shall fully correspond to the original issued document and shall be identified as such.

Communication of this European Technical Assessment, including transmission by electronic means, shall be in full. However, partial reproduction may only be made with the written consent of the issuing Technical Assessment Body. Any partial reproduction shall be identified as such.

This European Technical Assessment may be withdrawn by the issuing Technical Assessment Body, in particular pursuant to information by the Commission in accordance with Article 25(3) of Regulation (EU) No 305/2011.

## Specific Part

### 1 Technical description of the product

Objects of this European Technical Assessment are Hilti pipe clamps MP-L-I M8/M10. The pipe clamps MP-L-I M8/M10 consist of two profiled steel strips, which are designed to be able to surround a pipe circularly. The clamping strips are connected together by a steel hinge and a steel screw and are pressed onto the outside of the pipe to be fastened by tightening the screw. Each pipe clamp has a designated clamping range. The top clamping strip features a welded connection head with M8/M10 combi-thread. The clamping strips are fitted with an EDPM profile on the inside to aid structure-borne sound insulation, to balance unevenness and to prevent contact corrosion.

Annex A describes the dimensions and materials of the Hilti pipe clamps MP-L-I M8/M10.

### 2 Specification of the intended use in accordance with the applicable European Assessment Document (EAD)

The performance given in Section 3 can only be assumed if the Hilti pipe clamps MP-L-I M8/M10 are used in compliance with the specifications and under boundary conditions set out in Annex B. The test and assessment methods on which this European Technical Assessment is based lead to an assumption of a working life of the Hilti pipe clamps MP-L-I M8/M10 of at least 50 years in final use under ambient temperatures in indoor areas. The indications given on the working life cannot be interpreted as a guarantee given by the producer, but are to be regarded only as a means for choosing the right products in relation to the expected economically reasonable working life of the works.

In accordance with the European Assessment Document EAD 280016-00-0602, the product is intended to be used in

- a) installations for the support of sprinkler kits;
- b) installations for the support of other building service elements such as pipes, conduits, ducts and cables.

### 3 Performance of the product and references to the methods used for its assessment

#### 3.1 Safety in case of fire (BWR 2)

Essential characteristic	Performance
Reaction to fire: Steel	Class A1
Reaction to fire: Plastic parts	not relevant for fire growth based on TR021 and therefore do not need to be classified

#### 3.2 Safety and accessibility in use (BWR 4)

Essential characteristic	Performance
Shape	see Annex A
Dimensions	see Annex A
Material	see Annex A
Characteristic resistance at ambient temperatures	see Annex C

Essential characteristic	Performance
Service load and deformation at ambient temperature (Serviceability Limit State)	see Annex C
Resistance and deformation at elevated temperatures	see Annex D

**4 Assessment and verification of constancy of performance (AVCP) system applied, with reference to its legal base**

In accordance with the European Assessment Document EAD 280016-00-0602, the following legal bases apply:

- In case of intended use a) specified in Section 2:  
Decision of the commission N° 1996/577/EC:  
System 1 applies for the assessment and verification of constancy of performance (AVCP).
- In case of intended use b) specified in Section 2:  
Decision of the commission N° 1999/472/EC:  
System 3 applies for the assessment and verification of constancy of performance (AVCP).

**5 Technical details necessary for the implementation of the AVCP system, as provided for in the applicable EAD**

The technical details necessary for the implementation of the system for the assessment and verification of constancy of performance are laid down in the control plan (confidential part of this European Technical Assessment) deposited at Deutsches Institut für Bautechnik.

Issued in Berlin on 21 November 2018 by Deutsches Institut für Bautechnik

BD Dipl.-Ing. Andreas Kummerow  
Head of Department

*beglaubigt:*  
Dr.-Ing. Häßler

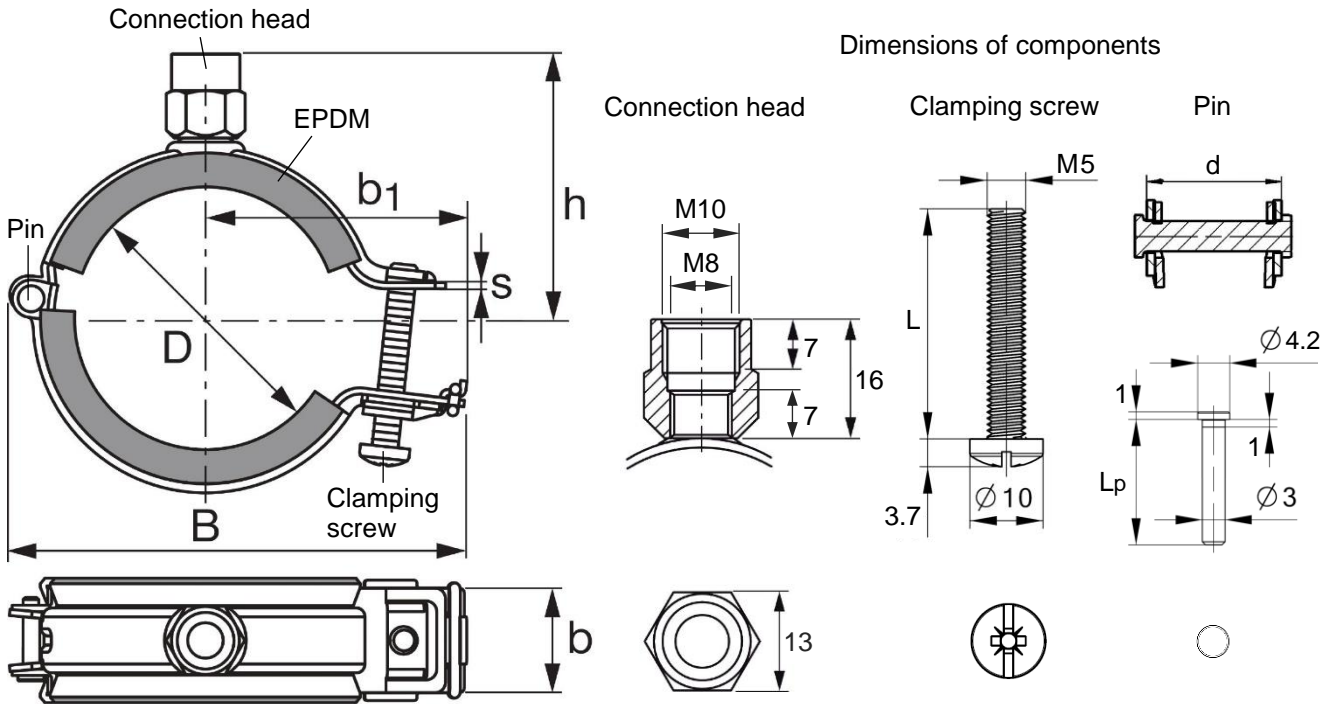

Dimensions in mm

Figure A1: Geometry und dimensions of the pipe clamp MP-L-I M8/M10

Table A1: Materials of pipe clamps MP-L-I M8/M10

Components of pipe clamps	Designation and coating	Standard / Technical delivery conditions
Steel clamping strip	SPCC-SD for the 0.8 mm strip, zinc coated DC01 for the 1.2 mm strip, zinc coated DC01 for the 1.5 mm strip, zinc coated	Details are deposited with DIBt
Steel connection head	ML08A1, zinc coated	Details are deposited with DIBt
Steel clamping screw M5	ML08A1, zinc coated	Details are deposited with DIBt
Steel pin	B-CHIT, zinc coated	Details are deposited with DIBt
Elasto inlays	EPDM	Details are deposited with DIBt

Hilti pipe clamps MP-L-I M8/M10

Product description  
Dimensions and materials

Annex A1

Table A2: Dimensions of pipe clamps MP-L-I M8/M10

Item number	Designation	D [mm]	B [mm]	b x s [mm]	h [mm]	b1 [mm]	L [mm]	Lp [mm]	d [mm]
2172815	MP-L-I 10-14 M8/10	10-14	64	20 x 0.80	29	29	25	16.5	13.4
2172816	MP-L-I 15-20 M8/10	15-20	69	20 x 0.80	32	31	25	16.5	13.4
2172817	MP-L-I 20-26 M8/10	20-26	75	20 x 0.80	36	34	30	16.5	13.4
2172818	MP-L-I 26-32 M8/10	26-32	83	20 x 0.80	39	38	30	16.5	13.4
2172819	MP-L-I 32-38 M8/10	32-38	92	20 x 0.80	42	41	30	16.5	13.4
2172920	MP-L-I 38-45 M8/10	38-45	101	20 x 0.80	45	45	35	16.5	13.4
2172921	MP-L-I 45-53 M8/10	45-53	107	20 x 1.20	51	50	35	16.5	13.4
2172922	MP-L-I 54-63 M8/10	54-63	111	20 x 1.20	56	55	40	16.5	13.4
2172923	MP-L-I 63-72 M8/10	63-72	123	20 x 1.20	60	60	40	16.5	13.4
2172924	MP-L-I 73-82 M8/10	73-82	130	20 x 1.20	65	65	40	16.5	13.4
2172925	MP-L-I 83-92 M8/10	83-92	139	20 x 1.20	68	70	40	16.5	13.4
2172926	MP-L-I 93-103 M8/10	93-103	144	20 x 1.20	71	76	45	16.5	13.4
2172927	MP-L-I 104-114 M8/10	104-114	163	20 x 1.20	78	81	45	16.5	13.4
2172928	MP-L-I 115-128 M8/10	115-128	174	25 x 1.50	84	90	50	18.0	15.5
2172929	MP-L-I 129-142 M8/10	129-142	179	25 x 1.50	86	97	50	18.0	15.5
2172930	MP-L-I 143-156 M8/10	143-156	187	25 x 1.50	90	194	50	18.0	15.5
2172931	MP-L-I 157-170 M8/10	157-170	198	25 x 1.50	95	111	50	18.0	15.5

Hilti pipe clamps MP-L-I M8/M10

Product description  
Dimensions

Annex A2

- Hilti pipe clamps MP-L-I M8/M10 are used to transfer the loads of building services components such as ducts and equipment for sprinkler, water, heating, cooling, ventilation, electrical and other installations. The pipe clamps MP-L-I M8/M10 are suitable for undertaking this load-bearing function under the conditions described in Section 2 of this European Technical Assessment.
- The resistance and deformation at ambient and elevated temperatures apply for static and centric actions.
- The resistance and deformation at elevated temperatures are referring to the boundary conditions of the standard temperature / time curve (STTC) in accordance with EN 1363-1.
- The performance data for the pipe clamp MP-L-I M8/M10 results in conjunction with the threaded rods as per Table B1.
- Prior to installation, it must be ensured that the pipe to be inserted, the anchoring of the threaded rods to the base material and the base material itself are suitable to withstand the resistance values of the pipe clamp MP-L-I and that they have a fireproof certificate.
- The pipe clamps MP-L-I M8/M10 must be installed by appropriately qualified personnel and under the supervision of the site manager. The general installation instructions of the manufacturer apply.

Table B1: Threaded rods for use with pipe clamps MP-L-I M8/M10

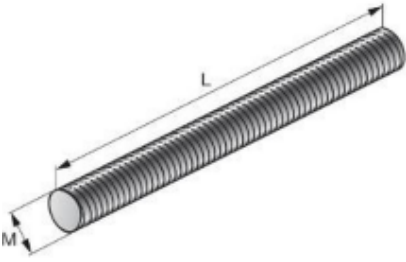
Illustration	Item number	Designation	M thread	L [mm]	Material
	216418	AM10x3000 4.8	M10	3000	Strength class 4.8 in accordance with DIN 976-1, zinc coated
	339796	AM10x2000 4.8	M10	2000	
	339795	AM10x1000 4.8	M10	1000	

Hilti pipe clamps MP-L-I M8/M10

Requirements for performance assessment

Annex B

Table C1: Characteristic tensile strength at ambient temperature

Item number	Designation	Characteristic tensile strength	Partial safety coefficient <sup>1)</sup>
		$F_{Rk}$ [kN]	$\gamma_M$
2172815	MP-L-I 10-14 M8/10	1.75	3.13
2172816	MP-L-I 15-20 M8/10		
2172817	MP-L-I 20-26 M8/10		
2172818	MP-L-I 26-32 M8/10		
2172819	MP-L-I 32-38 M8/10		
2172920	MP-L-I 38-45 M8/10		
2172921	MP-L-I 45-53 M8/10	2.68	2.40
2172922	MP-L-I 54-63 M8/10		
2172923	MP-L-I 63-72 M8/10		
2172924	MP-L-I 73-82 M8/10		
2172925	MP-L-I 83-92 M8/10		
2172926	MP-L-I 93-103 M8/10		
2172927	MP-L-I 104-114 M8/10	4.06	2.15
2172928	MP-L-I 115-128 M8/10		
2172929	MP-L-I 129-142 M8/10		
2172930	MP-L-I 143-156 M8/10		
2172931	MP-L-I 157-170 M8/10		

<sup>1)</sup> provided that no other national regulations apply

Hilti pipe clamps MP-L-I M8/M10

Characteristic resistance at ambient temperature

Annex C1



Table C2: Service load and deformation at ambient temperature

Item number	Designation	Service load $F_{SLs}$ [kN]	Associated deformation [mm]
2172815	MP-L-I 10-14 M8/10	0.748	1.50
2172816	MP-L-I 15-20 M8/10		
2172817	MP-L-I 20-26 M8/10		
2172818	MP-L-I 26-32 M8/10		
2172819	MP-L-I 32-38 M8/10		
2172920	MP-L-I 38-45 M8/10		
2172921	MP-L-I 45-53 M8/10	1.135	2.28
2172922	MP-L-I 54-63 M8/10		
2172923	MP-L-I 63-72 M8/10		
2172924	MP-L-I 73-82 M8/10		
2172925	MP-L-I 83-92 M8/10		
2172926	MP-L-I 93-103 M8/10		
2172927	MP-L-I 104-114 M8/10	1.876	3.40
2172928	MP-L-I 115-128 M8/10		
2172929	MP-L-I 129-142 M8/10		
2172930	MP-L-I 143-156 M8/10		
2172931	MP-L-I 157-170 M8/10		

Hilti pipe clamps MP-L-I M8/M10

Service load and deformation at ambient temperature

Annex C2

Table D1: Resistance and deformation at elevated temperatures

Item number	Designation	Parameter of regression curve		$F_{Rk,30}(\delta)$ [N]	$F_{Rk,t}$ [N]
		$F_{Rk,30}(\delta) = a_3 (a_1 * \delta^{a_2})$	$F_{Rk}(t) = c_3 (c_1 + c_2 / t)$		
2172815	MP-L-I 10-14 M8/10	$a_1 = 84.1275$ $a_2 = 0.2949$ $a_3 = 0.7642$ $8 \text{ mm} \leq \delta \leq 25 \text{ mm}$	$c_1 = 78.64$ $c_2 = 4125.30$ $c_3 = 0.8252$ $18 \text{ min} \leq t < 60 \text{ min}$	$F_{Rk,30}(10) = 127 \text{ N}$ $F_{Rk,30}(15) = 143 \text{ N}$ $F_{Rk,30}(20) = 156 \text{ N}$ $F_{Rk,30}(25) = 166 \text{ N}$	$F_{Rk,30} = 178 \text{ N}$
2172816	MP-L-I 15-20 M8/10				
2172817	MP-L-I 20-26 M8/10				
2172818	MP-L-I 26-32 M8/10				
2172819	MP-L-I 32-38 M8/10				
2172920	MP-L-I 38-45 M8/10				
2172921	MP-L-I 45-53 M8/10	$a_1 = 27.467$ $a_2 = 0.8650$ $a_3 = 0.8555$ $13 \text{ mm} \leq \delta \leq 19 \text{ mm}$	$c_1 = 208.97$ $c_2 = 4242.50$ $c_3 = 0.7259$ $20 \text{ min} \leq t < 60 \text{ min}$	$F_{Rk,30}(13) = 216 \text{ N}$ $F_{Rk,30}(16) = 259 \text{ N}$ $F_{Rk,30}(19) = 300 \text{ N}$	$F_{Rk,30} = 254 \text{ N}$
2172922	MP-L-I 54-63 M8/10				
2172923	MP-L-I 63-72 M8/10				
2172924	MP-L-I 73-82 M8/10				
2172925	MP-L-I 83-92 M8/10				
2172926	MP-L-I 93-103 M8/10				
2172927	MP-L-I 104-114 M8/10	$a_1 = 126.43$ $a_2 = 0.3679$ $a_3 = 0.7489$ $13 \text{ mm} \leq \delta \leq 34 \text{ mm}$	$c_1 = 169.23$ $c_2 = 9018.26$ $c_3 = 0.8056$ $27 \text{ min} \leq t \leq 58 \text{ min}$	$F_{Rk,30}(15) = 256 \text{ N}$ $F_{Rk,30}(20) = 285 \text{ N}$ $F_{Rk,30}(25) = 309 \text{ N}$ $F_{Rk,30}(30) = 331 \text{ N}$ $F_{Rk,30}(34) = 346 \text{ N}$	$F_{Rk,30} = 378 \text{ N}$
2172928	MP-L-I 115-128 M8/10				
2172929	MP-L-I 129-142 M8/10				
2172930	MP-L-I 143-156 M8/10				
2172931	MP-L-I 157-170 M8/10				

**Designation**

$\delta$  Deformation [mm]

$F_{Rk,30}(\delta)$  Load displacement function for an exposure time  $t = 30$  minutes to elevated temperatures [N]

$F_{Rk,t}$  Resistance after an exposure time  $t$  to elevated temperatures [N]

$F_{Rk}(t)$  Resistance time function at elevated temperatures [N]

Hilti pipe clamps MP-L-I M8/M10

Resistance and deformation at elevated temperatures

Annex D

- The screw for the pipe clamps MP-L-I M8/M10 must be tightened consistently with a torque of 2 Nm.

