

Approval body for construction products
and types of construction

Bautechnisches Prüfamt

An institution established by the Federal and
Laender Governments



European Technical Assessment

ETA-08/0323
of 11 October 2019

English translation prepared by DIBt - Original version in German language

General Part

Technical Assessment Body issuing the
European Technical Assessment:

Deutsches Institut für Bautechnik

Trade name of the construction product

weber.therm-Wärmedämm-Verbundsystem A 100/A 200
weber.therm-Wärmedämm-Verbundsystem AM 400

Product family
to which the construction product belongs

Product area code: 4
External Thermal Insulation Composite System with
rendering on mineral wool intended for use on building
walls

Manufacturer

Saint-Gobain Weber GmbH
Schanzenstraße 84
40549 Düsseldorf
DEUTSCHLAND

Manufacturing plant

Saint-Gobain Weber GmbH
Meiersberger Straße
42489 Wülfrath
DEUTSCHLAND

This European Technical Assessment
contains

19 pages including 5 annexes which form an integral part
of this assessment

Annex 6 Control Plan contains confidential information
and is not included in the European Technical
Assessment when that assessment is publicly available

This European Technical Assessment is
issued in accordance with Regulation (EU)
No 305/2011, on the basis of

ETAG 004, edition 2000, amended 2013,
used as EAD according to Article 66 Paragraph 3 of
Regulation (EU) No 305/2011.

The European Technical Assessment is issued by the Technical Assessment Body in its official language. Translations of this European Technical Assessment in other languages shall fully correspond to the original issued document and shall be identified as such.

Communication of this European Technical Assessment, including transmission by electronic means, shall be in full. However, partial reproduction may only be made with the written consent of the issuing Technical Assessment Body. Any partial reproduction shall be identified as such.

This European Technical Assessment may be withdrawn by the issuing Technical Assessment Body, in particular pursuant to information by the Commission in accordance with Article 25(3) of Regulation (EU) No 305/2011.

Specific part

1 Technical description of the product

1.1 Definition of the kit

This product is an External Thermal Insulation Composite System (ETICS) with rendering - a kit comprising components which are factory-produced by the manufacturer or component suppliers. It's made up on site from these. The ETICS manufacturer is ultimately responsible for all components of the ETICS specified in this ETA.

The ETICS kit comprises a prefabricated insulation product of mineral wool (MW) to be bonded and if it necessary additional mechanically fixed onto a wall. The methods of fixing and the relevant components are specified in the table below. The insulation product is faced with a rendering system consisting of one base coat and finishing coat (site applied), in which the base coat contains reinforcement. The rendering is applied directly to the insulating panels, without any air gap or disconnecting layer.

The ETICS may include special fittings (e.g. base profiles, corner profiles ...) for connection to adjacent building elements (apertures, corners, parapets ...). Assessment and performance of these components is not addressed in this ETA, however the ETICS manufacturer is responsible for adequate compatibility and performance within the ETICS when the components are delivered as a part of the kit.

1.2 Composition of the ETICS

	Components National application documents shall be taken into account	Coverage [kg/m ²]	Thickness [mm]
Insulation material with associated method of fixing	Bonded ETICS: <ul style="list-style-type: none"> • Insulation product (see annex 1 for product characteristics) factory-prefabricated mineral wool (MW) product <ul style="list-style-type: none"> - MW lamella • Adhesives <ul style="list-style-type: none"> - weber.therm 300 (cement based powder requiring addition of about 27 % of water) - weber.therm 301 (cement based powder requiring addition of about 25 % of water) - weber.therm 370 (cement based powder requiring addition of about 22 % of water) - weber.therm retec 700 (cement based powder requiring addition of about 27 % of water) - weber.therm retec 740 (cement based powder requiring addition of about 27 % of water) 	-	≤ 200
	Mechanically fixed ETICS with profiles and supplementary adhesive: <ul style="list-style-type: none"> • Insulation product (see annex 1 for product characteristics) factory-prefabricated mineral wool (MW) product <ul style="list-style-type: none"> - MW panel, $\sigma_{mt} \geq 14$ kPa 	-	60 to 200

	Components National application documents shall be taken into account	Coverage [kg/m ²]	Thickness [mm]
Insulation material with associated method of fixing	<ul style="list-style-type: none"> • Supplementary adhesive (equal to bonded ETICS) • Profiles (see annex 3 for product characteristics) <ul style="list-style-type: none"> - "Halteleiste Alu" and - "Verbindungsleiste Alu" Aluminium (Al) – profiles • Anchors for profiles (see annex 2 for product characteristics) <ul style="list-style-type: none"> - WS 8 L - ejothem SDK U - SDF-K plus - ejothem NK U • Anchors for insulation product if necessary (equal to mechanically fixed ETICS with anchors and supplementary adhesive, see below) 		
	Mechanically fixed ETICS with anchors and supplementary adhesive: <ul style="list-style-type: none"> • Insulation product (see annex 1 for product characteristics) factory-prefabricated mineral wool (MW) product <ul style="list-style-type: none"> - MW panel - MW lamella • Supplementary adhesive (equal to bonded ETICS) • Anchors for insulation product (see annex 2 for product characteristics) all anchors with ETA according to EAD330196-01-0604¹ 	–	60 bis 200
Base coat	weber.therm 300 weber.therm 301 weber.therm retec 700 weber.therm retec 740 Identical with the equally named adhesive(s) given above.	} about 7.0 (powder)	5.0 to 7.0 4.0 to 7.0 5.0 to 7.0 5.0 to 7.0
Glass fibre mesh	weber.therm 310 Alkali- and slide-resistant glass fibre mesh with mass per unit area of about 200 g/m ² and mesh size of about 8 mm x 8 mm. (see annex 4 for product characteristics)	–	–
	weber.therm 311* Alkali- and slide-resistant glass fibre mesh with mass per unit area of about 160 g/m ² and mesh size of about 4 mm x 4 mm. (see annex 4 for product characteristics)	–	–

¹ EAD330196-01-0604

Plastic anchors for fixing of external thermal insulation composite systems with rendering

	Components National application documents shall be taken into account	Coverage [kg/m ²]	Thickness [mm]
Key coat	weber.prim 403 Ready to use pigmented liquid with styrol-acrylat binder For the compatibility with the finishing coats see below.	about 0.3 l/m ²	–
Finishing coat	<p>To use without key coat:</p> <ul style="list-style-type: none"> Thick layered cement based powder requiring addition of about 20 % of water (scraped render): weber.top 200, 203, 204, 205, 206** <p>To use with key coat if applicable :***</p> <ul style="list-style-type: none"> Thin layered cement based powder requiring addition of about (20 – 35) % of water: weber.star 220, 221, 222, 223** (particle size 1,5 – 2.0 – 3.0 – 4.0 and 5.0 mm) weber.star 240, 241, 242, 244** (particle size 1,5 – 2.0 – 3.0 – 4.0 and 5.0 mm) weber.star 260, 261** weber.star 270 weber.star 271 weber.star 272, 280** Ready to use paste – potassium silicate binder: weber.pas 460, 461** (particle size 1.0 – 1.5 – 2.0 – 3.0 and 4.0 mm) 	<p>10.0 to 24.0</p> <p>2.5 to 5.0 (powder)</p> <p>2.5 to 5.0 (powder)</p> <p>3.0 to 5.0</p> <p>4.0 to 5.0</p> <p>about 8.0</p> <p>6.0 to 10.0 (powder)</p> <p>2.5 to 4.0</p>	<p>5.0 to 12.0</p> <p>Regulated by particle size</p> <p>3.0 to 5.0</p> <p>3.0 to 5.0</p> <p>about 6.0</p> <p>5.0 to 10.0</p> <p>Regulated by particle size</p>
Ancillary material	Remains the responsibility of the manufacturer.		
<p>* The glass fibre mesh "weber.therm 311" is to be used with the base coat "weber.therm 301" with d ≤ 5 mm only.</p> <p>** The different numbers indicate different grain structures only.</p> <p>*** The instruction to the installer concerning the use of a key coat remains the responsibility of the ETA-holder.</p>			

2 Specification of the intended use in accordance with the applicable European assessment Document (hereinafter called EAD)

2.1 Intended use

This ETICS is intended to be used as external insulation to the walls of buildings made of masonry (bricks, blocks, stones ...) or concrete (cast on site or as prefabricated panels) with and without rendering. The characteristics of the walls shall be verified prior to use of the ETICS, especially regarding conditions for reaction to fire classification and for fixing of the ETICS either by bonding or mechanically. It shall be designed to give the wall to which it is applied satisfactory thermal insulation.

The ETICS is non load-bearing construction element. It does not contribute directly to the stability of the wall on which it is installed, but it can contribute to durability by providing enhanced protection from the effects of weathering.

The ETICS can be used on new or existing (retrofit) vertical walls.

The ETICS is not intended to ensure the air tightness of the building structure.

The choice of the method of fixing depends on the characteristics of the substrate, which could need preparation (see clause 7.2.1 of ETAG 004) and on the national instructions.

The verifications and assessment methods on which this European Technical Assessment (hereinafter called ETA) is based lead to the assumption of a working life of the ETICS "weber.therm-Wärmdämm-Verbundsystem A 100 / A 200" and the "weber.therm-Wärmdämm-Verbundsystem AM 400" of at least 25 years. The indications given on the working life cannot be interpreted as a guarantee given by the manufacturer, but are to be regarded only as a means for choosing the right products in relation to the assumed economically reasonable working life of the works.

2.2 Manufacturing

The ETA is issued for the ETICS on the basis of agreed data/information, deposited with the DIBt, which identifies the ETICS that has been assessed and judged. Changes to the ETICS or the components or their production process, which could result in this deposited data/information being incorrect, should be notified to the DIBt before the changes are introduced. The DIBt will decide whether such changes affect the approval and consequently the validity of the CE marking on the basis of the approval and if so whether further assessment or alterations to the approval shall be necessary.

2.3 Design and installation

The installation instructions including special installation techniques and provisions for the qualification of the personnel are given in the manufacturer's technical documentation. Design, installation and execution of ETICS are to be in conformity with national documents. Such documents and the level of their implementation in Member States' legislation are different. Therefore, the assessment and declaration of performance are done taking into account general assumptions introduced in the chapters 7.1 and 7.2 of ETAG 004 used as EAD, which summarize how information introduced in the ETA and related documents is intended to be used in the construction process and gives advice to all parties interested when normative documents are missing.

2.4 Packing, transport and storage

The information on packaging, transport and storage is given in the manufacturer's technical documentation. It is the responsibility of the manufacturer to ensure that this information is made known to the concerned people.

2.5 Use, maintenance, repair

The finishing coat shall normally be maintained in order to fully preserve the ETICS performance. Maintenance includes at least:

- visual inspection of the ETICS,
- the repairing of localized damaged areas due to accidents,
- the aspect maintenance with products adapted and compatible with the ETICS (possibly after washing or ad hoc preparation).

Only products which are compatible with the ETICS shall be used.

Necessary repairs should be performed as soon as the need has been identified.

The information on use, maintenance and repair is given in the manufacturer's technical documentation.

It is the responsibility of the manufacturer to ensure that this information is made known to the concerned people.

3 Characteristics of products and methods of verification

3.0 General

The performances of the kit as described in this chapter are valid provided that the components of the kit comply with annexes 1 to 4.

3.1 Mechanical resistance and stability (BWR 1)

not relevant

3.2 Safety in case of fire (BWR 2)

Reaction to fire (ETAG 004 - clause 5.1.2)

Configuration	Organic content	Flame retardant content	Euroclass according to EN 13501-1:2007
Base coat	max. 2.3 %	no flame retardant	A2 – s1,d0
Mineral wool-insulation product	in quantity ensuring Euroclass A1 according to EN 13501-1	no flame retardant	
profiles	-	-	
anchors	-	-	
rendering system: Base coat with finishing coat and compatible key coat indicated in clause 1.2:			
- weber.top 200, 203, 204, 205, 206 - weber.star 220, 221, 222, 223 - weber.star 240, 241, 242, 244 - weber.star 260, 261 - weber.star 270 - weber.star 271 - weber.star 272, 280	max. 2.6 %	no flame retardant	
- weber.pas 460, 461	max. 6.9 %	no flame retardant	

3.3 Hygiene, health and environment (BWR 3)

3.3.1 Water absorption (capillarity test) (ETAG 004 – clause 5.1.3.1)

Base coat	Water absorption after 1 h < 1.0 kg/m ²	Water absorption after 24 h < 0.5 kg/m ²
weber.therm 300	x	x
weber.therm 301	x	x
weber.therm retec 700	x	x
weber.therm retec 740	x	x

Rendering system:

		Water absorption after 24 hours	
		< 0.5 kg/m ²	≥ 0.5 kg/m ²
Rendering system: Base coat with finishing coat indicated in clause 1.2:	- weber.top 200, 203, 204, 205, 206	x	
	- weber.star 220, 221, 222, 223 - weber.star 240, 241, 242, 244 - weber.star 260, 261 - weber.star 270 - weber.star 271 - weber.star 272, 280	x	
	- weber.pas 460, 461	x	

3.3.2 Hygrothermal behaviour (ETAG 004 – clause 5.1.3.2)

Hygrothermal cycles tests have not been performed for the ETICS.

3.3.3 Impact resistance (ETAG 004 – clause 5.1.3.3)

The impact resistance of all configurations of the ETICS is not assessed (npd).

3.3.4 Water vapour permeability (ETAG 004 – clause 5.1.3.4)

Rendering system: Base coat with finishing coat and compatible key coat indicated in clause 1.2: (evaluated without decorative coating or key coat)	Equivalent air thickness s_d
- weber.top 200, 203, 204, 205, 206	≤ 1.0 m (Test result obtained with base coat "weber.therm 300" and finish coat "weber.top 204", layer thickness 8 mm: 0.2 m)
- weber.star 220, 221, 222, 223 - weber.star 240, 241, 242, 244 - weber.star 260, 261 - weber.star 270 - weber.star 271 - weber.star 272, 280	≤ 1.0 m (Test result obtained with base coat "weber.therm 300" and finish coat "weber.star 220", particle size 5 mm: 0.2 m)
- weber.pas 460, 461	≤ 1,0 m (Test result obtained with base coat "weber.therm 300" and finish coat "weber.pas 461", particle size 4 mm: 0.3 m)

3.3.5 Release of dangerous substances (ETAG 004 – clause 5.1.3.5, EOTA TR 034)

Essential characteristic	Performance
Release of dangerous substances	no performance assessed

3.4 Safety and accessibility in use (BWR 4)

3.4.1 Bond strength between base coat and insulation product (MW) (ETAG 004 – clause 5.1.4.1.1)

Base coat	Conditioning		
	Initial state	After hygrothermal cycles	After freeze/thaw test
weber.therm 300	≥ 0.08 MPa	< 0,08 MPa jedoch Versagen im Wärmedämmstoff	Test not required because freeze/thaw cycles not necessary
weber.therm 301	≥ 0.08 MPa		
weber.therm retec 700	≥ 0.08 MPa		
weber.therm retec 740	≥ 0.08 MPa		

3.4.2 Bond strength between adhesive and substrate resp. insulation product (EPS) (MW lamella) (ETAG 004 – clauses 5.1.4.1.2 and 5.1.4.1.3)

Adhesive	Substrate resp. insulation product	Conditioning		
		Initial state	2 d immersion in water and 2 h drying	2 d immersion in water and 7 d drying
weber.therm 300	Concrete	≥ 0.25 MPa	≥ 0.08 MPa	≥ 0.25 MPa
	MW lamella	≥ 0.08 MPa	≥ 0.03 MPa	≥ 0.08 MPa
weber.therm 301	Concrete	≥ 0.25 MPa	≥ 0.08 MPa	≥ 0.25 MPa
	MW lamella	≥ 0.08 MPa	≥ 0.03 MPa	≥ 0.08 MPa
weber.therm 370	Concrete	≥ 0.25 MPa	≥ 0.08 MPa	≥ 0.25 MPa
	MW lamella	≥ 0.08 MPa	≥ 0.03 MPa	≥ 0.08 MPa
weber.therm retec 700	Concrete	≥ 0.25 MPa	≥ 0.08 MPa	≥ 0.25 MPa
	MW lamella	≥ 0.08 MPa	≥ 0.03 MPa	≥ 0.08 MPa
weber.therm retec 740	Concrete	≥ 0.25 MPa	≥ 0.08 MPa	≥ 0.25 MPa
	MW lamella	≥ 0.08 MPa	≥ 0.03 MPa	≥ 0.08 MPa

Bonded surface:

With a bonded surface of 50 % the formula given in clause 6.1.4.1.3 of ETAG 004 is fulfilled and the use as bonded ETICS is possible.

3.4.3 Bond strength after ageing (ETAG 004 – clause 5.1.7.1):

An extensive experience on site has been assessed by the DIBT in Germany.

The rendering system (all base coats with each finishing coat indicated in the Table in clause 1.2) has proved its bond strength after ageing by experience on site.

3.4.4 Fixing strength (displacement test) (ETAG 004 – clause 5.1.4.2)

Test not required therefore no limitation of ETICS length required.

3.4.5 Wind load resistance (ETAG 004 – clause 5.1.4.3)

The following failure loads only apply to the listed combination of component characteristics and the characteristics of the insulation product given in annex 1.

English translation prepared by DIBt

3.4.5.1 Safety in use of mechanically fixed ETICS using profiles

Failure loads – table 1

Characteristics of the MW panels	Dimensions	625 mm x 800 mm
	Thickness	≥ 60 mm
	Tensile strength perpendicular to the faces	≥ 14 kPa
Failure load [N/panel] (Static Foam Block Test)	Horizontal profiles with a vertical distance of 625 mm, fixed every 30 cm and vertical connection profiles No additional anchors in MW panel	Minimal: 1200 Average: 1250

Failure loads – table 2

Characteristics of the MW panels	Dimensions	625 mm x 800 mm
	Thickness	≥ 60 mm
	Tensile strength perpendicular to the faces	≥ 14 kPa
Failure load [N/panel] (Static Foam Block Test)	Horizontal profiles with a vertical distance of 625 mm, fixed every 30 cm and vertical connection profiles Two additional anchors per MW panel, plate diameter ≥ 60 mm, mounted on the MW panel surface	Minimal: 2200 Average: 2400

3.4.5.2 Safety in use of mechanically fixed ETICS using anchors

Failure loads – table 3

Apply to all anchors listed in the clause 1.2 mounted on the insulation panels surface			
Characteristics of the MW panels	Thickness		≥ 60 mm
	Tensile strength perpendicular to the faces		≥ 14 kPa
Plate diameter of anchor			≥ Ø 60 mm
Failure load [N]	Anchors not placed at the panel joints (Static Foam Block Test)	R_{panel}	Minimal: 650 Average: 740
	Anchors placed at the panel joints (Static Foam Block Test)	R_{joint}	Minimal: 590 Average: 610
	Anchors not placed at the panel joints (Pull-through test, dry conditions)	R_{panel}	Minimal: 640 Average: 690
	Anchors not placed at the panel joints (Pull-through test, wet conditions) - series 2* - series 3*	R_{panel}	Minimal: 360 Average: 390 Minimal: 410 Average: 450
* according to ETAG 004 (edition 2000) clause 5.2.4.1.2 test method (2)			

Failure loads – table 4

Apply to all anchors listed in the clause 1.2 mounted on the insulation panels surface				
Characteristics of the MW panels	Thickness		≥ 80 mm	
	Tensile strength perpendicular to the faces		≥ 5 kPa	
Plate diameter of anchor			≥ Ø 90 mm	≥ Ø 140 mm
Failure load [N]	Anchors not placed at the panel joints (Static Foam Block Test)	R_{panel}	Minimal: 480 Average: 490	Minimal: 56 Average: 69
	Anchors placed at the panel joints (Static Foam Block Test)	R_{joint}	Minimal: 380 Average: 390	Minimal: 44 Average: 54
	Anchors not placed at the panel joints (Pull-through test, dry conditions)	R_{panel}	Minimal: 540 Average: 610	npd
	Anchors not placed at the panel joints (Pull-through test, wet conditions) - series 2*	R_{panel}	Minimal: 400 Average: 460	npd
* according to ETAG 004 (edition 2000) clause 5.2.4.1.2 test method (2)				

Failure loads – Table 5

Apply to all anchors listed in clause 1.2 mounted on the insulation panels surface			
Characteristics of the MW lamella	Thickness		≥ 60 mm
	Tensile strength perpendicular to the faces		≥ 80 kPa
Plate diameter of anchor			≥ Ø 140 mm
Failure load [N]	Anchors placed at the panel joints (Pull-through test, dry condition)	R_{joint}	Minimal: 620 Average: 660
	Anchors placed at the panel joints (Pull-through test, wet condition)	R_{joint}	Minimal: 510 Average: 570
	Anchors placed at the panel joints (Static Foam Block Test)	R_{joint}	Minimal: 710

The failure loads of tables 2 and 3 specified above only apply to the following anchors with deep mounting under the given conditions of installation:

Anchor	Thickness of the MW panel [d]	Conditions of installation *
ejothem STR U ejothem STR U 2G (ETA-04/0023)	100 mm > d ≥ 80 mm	– Maximum installation depth of the anchor plate: 15 mm (≙ thickness of insulation cover) – Maximum depth of die: 5 mm
	≥ 100 mm	– Maximum installation depth of the anchor plate: 15 mm (≙ thickness of insulation cover) – Maximum depth of die: 20 mm
TERMOZ 8 SV (ETA-06/0180)	≥ 80 mm	– Maximum installation depth of the anchor plate: 15 mm (□ thickness of insulation cover)
* according to the appropriate ETA of anchor		

3.4.6 Render strip tensile test (ETAG 004 – clause 5.5.4.1)

The average value of crack width of the with different glass fibre meshes reinforced base coats measured at a render strain value of 1 % is:

Base coat	Glass fibre mesh	Average value of crack width $w_{m(1\%)}$
weber.therm 300	weber.therm 310	0,10 mm
weber.therm 301	weber.therm 310	0,07 mm
weber.therm 301	weber.therm 311	0,13 mm
weber.therm retec 700	weber.therm 310	0.10 mm
weber.therm retec 740	weber.therm 310	0.10 mm

3.5 Protection against noise (BWR 5)

For the protection against noise no performance was assessed for this product.

3.6 Energy economy and heat retention (BWR 6)

3.6.1 Thermal resistance

The nominal value of the additional thermal resistance R provided by the ETICS to the substrate wall is calculated in accordance with EN ISO 6946:2007 from the nominal value of the insulation product's thermal resistance R_D given accompanied to the CE marking and from the thermal resistance of the rendering system R_{render} which is about $0.02 (m^2 \cdot K)/W$.

$$R = R_D + R_{render}$$

The thermal bridges caused by mechanical fixing devices (anchors profiles) increase the thermal transmittance U . This influence had to take into account according to EN ISO 6946:2007.

$$U_c = U + \Delta U \quad \text{corrected thermal transmittance [W/(m}^2 \cdot \text{K)]}$$

$$\Delta U = \Delta U_{anchor} + \Delta U_{profile} \quad \text{correction term for mechanical fixing devices (anchors, profiles)}$$

$$\Delta U_{anchor} = \chi_p \cdot n \quad \text{correction term for anchors}$$

where: n number of anchors per m^2

χ_p local influence of thermal bridge caused by an anchor. The values listed below can be taken into account, if not specified in the anchor's technical approval

$\chi_p = 0.004 \text{ W/K}$ for anchors with a galvanized steel screw with the head covered by a plastic material

$\chi_p = 0.002 \text{ W/K}$ for anchors with a stainless steel screw with the head covered by plastic material, and for anchors with an air gap at the head of the screw

$$\Delta U_{profile} = \Psi \cdot l \quad \text{correction term for profiles; } \Delta U_{profile} \text{ is determined in accordance with EN ISO 10211:2007}$$

where: Ψ length thermal transmittance value of the profile $[W/(m \cdot K)]$

l length of profile per m^2 $[m/m^2]$

English translation prepared by DIBt

4 Assessment and verification of constancy of performance (AVCP) system applied, with reference to its legal base

According to the European Commission decision 97/556/EC amended by the European Commission decision 2001/596/EC, the assessment and verification of constancy of performance system (AVCP) applies suitable following table (see Annex V to Regulation (EU) No 305/2011).

Product	Intended use	Levels or classes (Reaction to fire)	Systems
"weber.therm-Wärmdämm-Verbundsystem A 100 / A 200"	ETICS in external wall subject to fire regulations	A1 ⁽¹⁾ , A2 ⁽¹⁾ , B ⁽¹⁾ , C ⁽¹⁾	1
		A1 ⁽²⁾ , A2 ⁽²⁾ , B ⁽²⁾ , C ⁽²⁾ , D, E, (A1 to E) ⁽³⁾ , F	2+
"weber.therm-Wärmdämm-Verbundsystem AM 400"	ETICS in external wall not subject to fire regulations	any	2+

⁽¹⁾ Products/materials for which a clearly identifiable stage in the production process results in an improvement of the reaction to fire classification (e. g. an addition of fire retardants or a limiting of organic material)
⁽²⁾ Products/materials not covered by footnote (1)
⁽³⁾ Products/materials that do not require to be tested for reaction to fire (e.g. products/materials of Classes A1 according to Commission Decision 96/603/EC)

5 Technical details necessary for the implementation of the AVCP system, as provided for in the applicable European Assessment Document (EAD)

Technical details necessary for the implementation of the AVCP system are laid down in the control plan deposited at Deutsches Institut für Bautechnik.

Issued in Berlin on 11 October 2019 by Deutsches Institut für Bautechnik

Dirk Brandenburger
Head of Department

beglaubigt:
Windhorst

Annexes:

- Annex 1: Thermal insulation product characteristic
- Annex 2: Anchors
- Annex 3: Profiles
- Annex 4: Reinforcement
- Annex 5: Trade names of the components

Annex 1: Thermal insulation product characteristic

Factory-prefabricated panels and lamella made of mineral wool (MW) to EN 13162:2015 with the following designation code and the other properties having the description in the Table below shall be used, provided that the manufacturer and the trade name of the MW are deposited with the DIBt.

MW – EN 13162 – T5 – DS(T+) – WS – WL(P) – MU1

Description and characteristics	MW panel***	MW panel	MW lamella
Reaction to fire; EN 13501-1:2007	Class A1		
Gross heat of combustion [MJ/kg]; EN ISO 1716:2010	PCS ≤ 1.4		
Thermal resistance [(m ² · K)/W]	Defined in the CE marking in reference to EN 13162:2015		
Tensile strength perpendicular to the faces [kPa]; EN 1607:2013 - in dry conditions*	$\sigma_{mt} \geq 14$	$\sigma_{mt} \geq 5$	$\sigma_{mt} \geq 80$
- in wet conditions** Average value - series 2 - series 3	≥ 33 % of average value in dry conditions ≥ 50 % of average value in dry conditions		
Compressive strength* [kPa]; EN 826:2013	$\sigma_m \geq 40$	$\sigma_m \geq 4$	$\sigma_m \geq 40$
Apparent density [kg/m ³]; EN 1602:2013	$120 \leq \rho_a \leq 150$	$100 \leq \rho_a \leq 150$	$80 \leq \rho_a \leq 150$
Shear strength* [kPa]; EN 12090:2013	$20 \leq f_{tk} \leq 100$	$6 \leq f_{tk} \leq 100$	$20 \leq f_{tk} \leq 100$
Shear modulus [MPa]; EN 12090:2013	$1.0 \leq G_m \leq 2.0$	$0.3 \leq G_m \leq 2.0$	$1.0 \leq G_m \leq 2.0$
* Minimal value of all single values ** according to ETAG 004 (edition 2000), clause 5.2.4.1.2 test method (2) resp. (3) *** Thermal insulation materials for mechanically fixed ETICS with profiles must circumferentially at the edges, 24 mm from the inner surface, get an approx. 3 mm wide and 13 to 18 mm deep groove cut-in at the factory.			

Annex 2: Anchors

All anchors with ETA according to EAD330196-01-0604¹ with characteristics having the description below shall be used in the mechanically fixed ETICS:

- plate diameter of anchor ≥ 60 mm resp. ≥ 90 mm or ≥ 140 mm
- plate stiffness ≥ 0.3 kN/mm
- load resistance of the anchor plate ≥ 1.0 kN

These characteristics and the characteristic tension resistance of the anchors shall be taken from the corresponding ETA.

The anchors listed in the Table in clause 1.2 with reference to the respective ETA shall be used in the mechanically fixed ETICS with profiles for fixing the horizontal profiles.

Trade name	ETA-number
WS 8 L	ETA-02/0019
IsoFux ND-8Z	ETA-04/0032
SDF-K plus	ETA-04/0064
ejotherm NK U	ETA-05/0009

Annex 3: Profiles

Aluminium (Al) profiles, EN AW-6060 T66 to EN 755-2: are to be used in the mechanically fixed ETICS with profiles.

The Pull-through resistance of fixings from profiles is ≥ 500 N.

Horizontal profile – "Halteleiste PVC" (dimensions in millimetres)

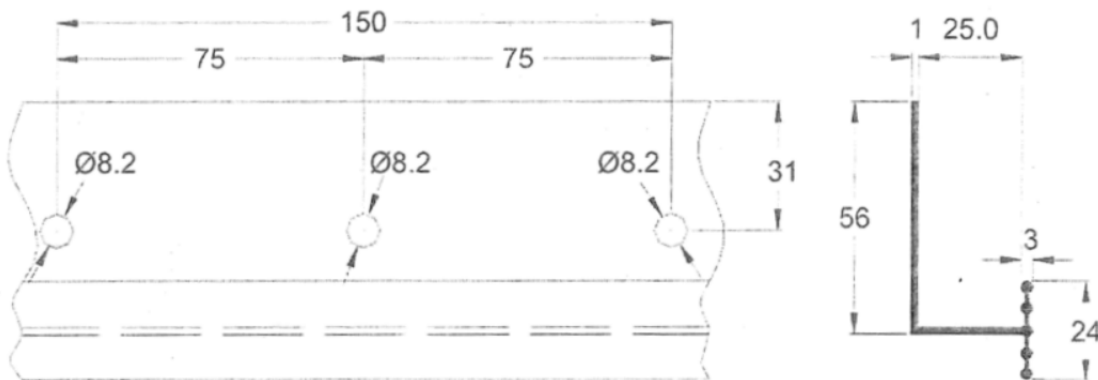

Länge: 2000 mm

Vertical connection profile – "Verbindungsleiste PVC" (dimensions in millimetres)

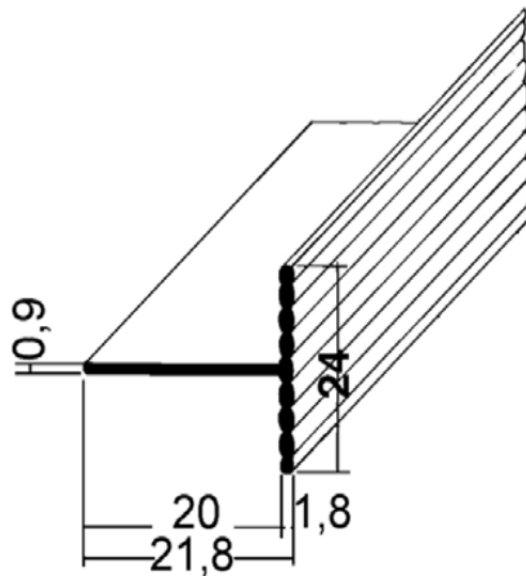

Länge: 590 mm

Annex 4: Reinforcement (glass fibre mesh)

Characteristics (alkali resistance): Pass

	Description	Residual strength after ageing [N/mm]		Relative residual strength after ageing, of the strength in the as-delivered state [%]	
		Warp	Weft	Warp	Weft
weber.therm 310	Alkali- and slide-resistant glass fibre mesh with mass per unit area of about 200 g/m ² and mesh size of about 8 mm x 8 mm	≥ 25	≥ 30	≥ 60	≥ 50
weber.therm 311	Alkali- and slide-resistant glass fibre mesh with mass per unit area of about 160 g/m ² and mesh size of about 4 mm x 4 mm	≥ 20	≥ 20	≥ 50	≥ 50

Annex 5: Trade names of the components

Components	Trade names acc. to the Table in clause 1.2	Further trade names
Adhesives	weber.therm 300	-
	weber.therm 301	weber.therm family KS grob weber.therm freestyle KS weber.therm prestige KS maxit multi Kleber und Armierungsmörtel
	weber.therm 370	-
	weber.therm rettec 700	-
	weber.therm rettec 740	-
Base coats	weber.therm 300	-
	weber.therm 301	weber.therm family KS grob weber.therm freestyle KS weber.therm prestige KS maxit multi Kleber und Armierungsmörtel
	weber.therm rettec 700	-
	weber.therm rettec 740	-
Glass fibre meshes	weber.therm 310	weber.therm Textilglasgittergewebe grob maxit Armierungsgewebe MW
	weber.therm 311	weber.therm Textilglasgittergewebe maxit Armierungsgewebe PS
Key coat	weber.prim 403	weber.prim Putzgrund
Finishing coats	weber.top 200, 203, 204, 205, 206	maxit ip Edelkratzputz
	weber.star 220, 221, 222	-
	weber.star 223	weber.min freestyle RP
	weber.star 240, 241, 242, 244	-
	weber.star 260, 261	-
	weber.star 270	-
	weber.star 271	-
	weber.star 272, 280	-
	weber.pas 460, 461	weber.pas Silikatputz weber.pas extraClean weber.pas decofino weber.pas modelfino
weber.pas 461	weber.pas decofino weber.pas modelfino	