

Approval body for construction products  
and types of construction

Bautechnisches Prüfamt

An institution established by the Federal and  
Laender Governments



## European Technical Assessment

**ETA-11/0189**  
**of 11 September 2019**

English translation prepared by DIBt - Original version in German language

### General Part

Technical Assessment Body issuing the  
European Technical Assessment:

Deutsches Institut für Bautechnik

Trade name of the construction product

Derix X-LAM

Product family  
to which the construction product belongs

Solid wood slab element to be used as a structural  
element in buildings

Manufacturer

W. u. J. Derix GmbH & Co.  
Dam 63  
41372 Niederkrüchten  
DEUTSCHLAND

Manufacturing plant

W. u. J. Derix GmbH & Co.  
Dam 63  
41372 Niederkrüchten  
DEUTSCHLAND  
Poppensieker & Derix GmbH & Co. KG  
Industriestraße 24  
49492 Westerkappeln  
DEUTSCHLAND

This European Technical Assessment  
contains

30 pages including 7 annexes which form an integral part  
of this assessment

This European Technical Assessment is  
issued in accordance with Regulation (EU)  
No 305/2011, on the basis of

EAD 130005-00-0304

This version replaces

ETA-11/0189 issued on 7 April 2016

The European Technical Assessment is issued by the Technical Assessment Body in its official language. Translations of this European Technical Assessment in other languages shall fully correspond to the original issued document and shall be identified as such.

Communication of this European Technical Assessment, including transmission by electronic means, shall be in full. However, partial reproduction may only be made with the written consent of the issuing Technical Assessment Body. Any partial reproduction shall be identified as such.

This European Technical Assessment may be withdrawn by the issuing Technical Assessment Body, in particular pursuant to information by the Commission in accordance with Article 25(3) of Regulation (EU) No 305/2011.

## Specific Part

### 1 Technical description of the product

Derix X-LAM is a cross laminated timber element made of softwood consisting of an odd number of 3 layers up to 11 layers. The lay-up of the cross laminated timber shall be symmetrical to its centre plane. The elements are plane.

Individual layers consist of parallel oriented lamellae made of strength graded boards or wood based panels. Wood based panel layers are bonded to layers made of softwood lamellae or solid wood panels perpendicular (angle of 90°) to each other. The overall thickness of the layers consisting of wood based panels is at most 50 % of the element thickness.

In elements with at least five layers, up to two adjacent layers are oriented with parallel grain direction. With the exception of the solid wood panels according to EN 13986 wood based panels are not arranged in two adjacent layers.

The components and the system setup of the product are given in Annex 2, Figure A.2.1 and Figure A.2.2.

The elements are not treated with wood preservatives and flame retardants.

Wood species are spruce, fir, pine, larch and Douglas fir. For layers consisting of wood based panels oriented strand boards (OSB), plywood, laminated veneer lumber (LVL), and single-layered solid wood panels in each case according to EN 13986 and laminated veneer lumber (LVL) according to EN 14374 are used, for which the load-bearing properties (bending strength, shear strength) are specified and which are intended for use in service class 2 according to EN 1995-1-1.

### 2 Specification of the intended use in accordance with the applicable European Assessment Document

The solid wood slab element is intended to be used as a structural or non-structural element in buildings and timber structures. They are designed to carry and transfer loads both perpendicular to the element plane and in the element plane.

The performances given in Section 3 are only valid if the solid wood slab elements are used in compliance with the specifications and conditions given in Annex 1 to 4.

The verifications and assessment methods on which this European Technical Assessment is based lead to the assumption of a working life of the solid wood slab element of at least 50 years. The indications given on the working life cannot be interpreted as a guarantee given by the producer, but are to be regarded only as a means for choosing the right products in relation to the expected economically reasonable working life of the works.

### 3 Performance of the product and references to the methods used for its assessment

#### 3.1 Mechanical resistance and stability <sup>1)</sup> (BWR 1)

Essential characteristic	Performance
Bending <sup>2)</sup>	See Annexes 2 to 4 (The performance characteristics are expressed by the geometric properties (lay-up of X-Lam, thicknesses of lamellas, etc.) and the strength and stiffness properties of the individual layers.)
Tension and compression <sup>2)</sup>	
Shear <sup>2)</sup>	
Embedment strength	Annex 3
Creep and duration of the load	Annex 3
Dimensional stability	Annex 3
In-service environment	Annex 3
Bond integrity	Annex 3
<sup>1)</sup> This characteristic also relates to BWR 4. <sup>2)</sup> Load bearing capacity and stiffness regarding mechanical actions perpendicular to and in plane of the solid wood slab element.	

For gluing the layers among each other to form a solid wood slab element as well as the finger joints of the individual boards an adhesive type I according to EN 301 or according to EN 15425 is to be used. Specifications are deposited with Deutsches Institut für Bautechnik.

#### 3.2 Safety in case of fire (BWR 2)

Essential characteristic	Performance
Reaction to fire	Annex 3
Resistance to fire	Annex 3

### 3.3 Hygiene, health and the environment (BWR 3)

Essential characteristic	Performance
Content, emission and/or release of dangerous substances	<p>The manufacturer has submitted a written declaration to the Technical Assessment Body (DIBt) that no dangerous substances &gt; 0.1 wt. % are used in the product assessed by the present ETA.</p> <p>Only wood based panels which can be assigned to formaldehyde class E1 according to EN 13986 shall be used.</p> <p>The use of wood preservatives and flame retardants is excluded.</p> <p>The chemical compositions of the adhesives for gluing the cross laminated timber among each other and the wood-based panels as well as the finger joints of the individual boards have to be in compliance with the chemical compositions deposited at the Technical Assessment Body (DIBt).</p>
Release scenarios regarding BWR 3 according to EOTA TR 034: IA 1, IA 2	
Water vapour permeability - Water vapour transmission	Annex 3

### 3.4 Safety and accessibility in use (BWR 4)

Essential characteristic	Performance
Impact resistance	Annex 3

### 3.5 Protection against noise (BWR 5)

Essential characteristic	Performance
Airborne sound insulation	Annex 3
Impact sound insulation	Annex 3
Sound absorption	Annex 3

### 3.6 Energy economy and heat retention (BWR 6)

Essential characteristic	Performance
Thermal conductivity	Annex 3
Air permeability	Annex 3
Thermal inertia	Annex 3

### 3.7 Sustainable use of natural resources (BWR 7)

The performance of this product in terms of sustainable use of natural resources has not been investigated.

English translation prepared by DIBt

**4 Assessment and verification of constancy of performance (AVCP) system applied, with reference to its legal base**

In accordance with EAD No. 130005-00-0304 the applicable European legal act is:  
1997/176/EC amended by 2001/596/EC

The system to be applied is: 1

**5 Technical details necessary for the implementation of the AVCP system, as provided for in the applicable EAD**

Technical details necessary for the implementation of the AVCP system are laid down in the control plan deposited with Deutsches Institut für Bautechnik.

Issued in Berlin on 11 September 2019 by Deutsches Institut für Bautechnik

Dr.-Ing. Lars Eckfeldt  
p. p. Head of Department

*beglaubigt:*  
Deniz

## Annex 1 Specifications of intended use

### A.1.1 Intended Use and Loading

The elements are intended to be used as load-bearing and/or stiffening or not load-bearing element in buildings and timber structures. They are designed to carry and transfer loads both perpendicular to the element plane and in the element plane.

The solid wood slab elements are intended to be subjected to static and quasi-static actions only.

The solid wood slab element is intended to be used in service classes 1 and 2 according to EN 1995-1-1.

Members which are directly exposed to the weather shall be provided with an effective protection for the solid wood slab element in service.

### A.1.2 Design

The suitability of the solid wood slab elements for the specified purpose is given under the following conditions:

- Design of the solid wood slab elements is carried out under the responsibility of an engineer experienced in such products.
- Design of the works accounts for the protection of the solid wood slab elements.
- The solid wood slab elements are installed correctly.

The design of the solid wood slab element can be performed according to EN 1995-1-1 in conjunction with the respective national annex, taking into account Annexes 2 to 6 of the European Technical Assessment. Standards and regulations applicable at the place of use shall be observed.

With the charring rates of the lamellas specified in Table A.3.1, the method according to the respective national versions of EN 1995-1-2, Section 3.4.3, taking into account the standards and regulations applicable at the place of use, is recommended.

### A.1.3 Packaging, transport, storage

The solid wood slab elements shall be protected during transport and storage against any damage and detrimental moisture effects. The manufacturer's instructions for packaging, transport and storage shall be observed.

### A.1.4 Installation provisions

EN 1995-1-1 in conjunction with the respective national annex applies for the installation.

The manufacturer provides assembling instructions in which the product-specific characteristics and important measures to be taken into consideration for assembling are described. The assembling instructions are available at every construction site.

The assembling of the solid wood slab elements according to this European Technical Assessment is carried out by appropriately qualified personnel.

The product shall only be installed in structures where they are protected from wetting, weathering and moisture.

The safety-at-work and health protection regulations have to be observed.

Derix X-LAM

Specifications of intended use

Annex 1

**Annex 2 Dimensions and specifications of the elements**

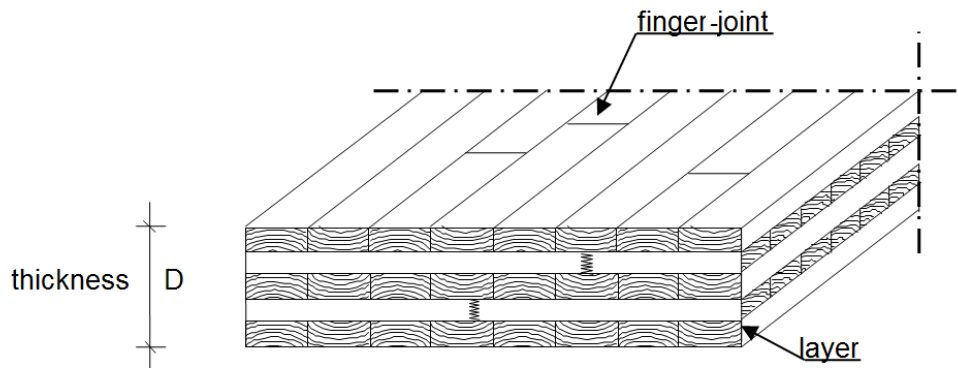

**Figure A.2.1:** Principle structure of the cross laminated timber element (here: example with five layers)

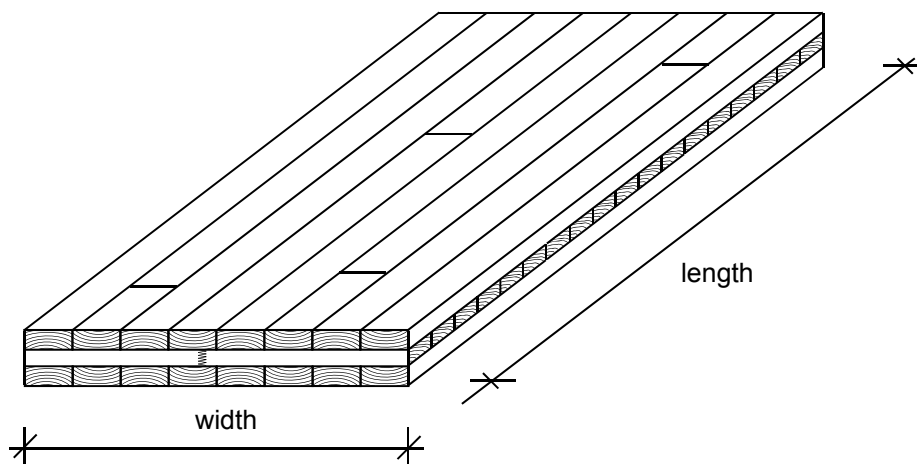

**Figure A.2.2:** Cross laminated timber element (here: example with three layers)

Electronic copy of the ETA by DIBt: ETA-11/0189

Derix X-LAM	Annex 2
Structure of the cross laminated timber element	



**Table A.2.1: Dimensions and specifications of the elements**

Characteristic	Dimensions and specifications
<b>Cross laminated timber element</b>	
Thickness	60 to 400 mm
Tolerance in thickness	± 2 mm if thickness ≤ 200 mm ± 3 mm if thickness > 200 mm
Width	≤ 3.50 m
Tolerance in width	± 3 mm
Length	≤ 18.00 m
Tolerance in length	± 3 mm
Number of layers	3 ≤ n ≤ 11
Number of consecutive layers having the same grain direction	≤ 2 for n ≥ 5
Maximum width of gaps between adjacent boards in longitudinal layers in cross layers for characteristic according to table A.3.1, line 2	3 mm 6 mm tightly butted boards (no gaps)
<b>Boards</b>	
Material	spruce, fir, pine, larch and douglas fir
Strength class according to EN 338 resp. EN 14081-1	≥ C16 <sup>*)</sup>
Surface	planed or grinded
Thickness in longitudinal layers in cross layers	15 to 45 mm 15 to 40 mm
Width	80 to 260 mm
Ratio width to thickness of the cross-layers	≥ 4:1
Moisture of wood according to EN 13183-2	8 ± 2.5; 9 ± 2.5, 10 ± 2.5; 11 ± 2.5, 12 ± 2.5 (in %) Within one cross laminated timber element only one of the specified moisture ranges shall be applied.
Finger joints	according to EN 14080
<b>Wood based panels</b>	
Material	OSB, plywood, LVL and single-layered solid wood panels according to EN 13986 and LVL according to EN 14374 from softwood <sup>**)</sup>
Thickness	15 to 45 mm
Joints	Wood-based panels may not be connected in longitudinal direction. Joints parallel to the longitudinal direction shall be taken into account.
<sup>*)</sup> In each layer 10 % of a lower strength class may be used. <sup>**)</sup> for which the load-carrying properties are specified and which are intended for use in service class 2 acc. to EN 1995-1-1	

Derix X-LAM

Dimensions and specifications of the cross laminated timber elements

Annex 2

### Annex 3 Essential requirements of the cross laminated timber

Table A.3.1: Essential requirements of the cross laminated timber

BWR	Requirement	Verification method	Class / Use category / Value		
1	<b>Mechanical resistance and stability</b>				
	The performance characteristics are expressed by the geometric properties (lay-up of CLT, thicknesses of lamellas, etc.) and the strength, stiffness and density properties of the individual layers; see also Annex 4. In addition the following values apply:				
	Mechanical actions in plane of cross laminated timber	shear strength for the calculation with the gross cross section (characteristic value)	$f_{v,k}$	as given in Table A.3.2 or in Annex 3	
		torsional shear strength of the glued area of crosswise bonded laminations (characteristic value)	$f_{v,tor,k}$	2.5 N/mm <sup>2</sup>	
	Mechanical actions perpendicular to the plane of cross laminated timber	rolling shear strength (characteristic value)	$f_{r,k}$	1.1 N/mm <sup>2</sup>	
		rolling shear modulus (mean value)	$G_{r,mean}$	50 N/mm <sup>2</sup>	
	For references regarding the design see Annexes 4 and 6.				
	Use of fasteners	according to EN 1995-1-1, for further details see Annex 5			
	Creep and duration of load	according to EN 1995-1-1			
	Dimensional stability	Moisture content during use shall not change to such an extent that adverse deformations can occur.			
	Durability of timber	spruce, fir, pine, larch and douglas fir (heartwood and sapwood) Durability see EN 335, EN 350 and EN 460			
In-service environment	EN 1995-1-1	service class 1 and 2			
Bond integrity	EAD 130005-00-0304	passed			
2	<b>Behaviour in case of fire</b>				
	<b>Reaction to fire</b>				
	Solid wood panels except for floorings	Commission Decision 2005/610/EC	Euroclass D-s2, d0		
	<b>Resistance to fire</b>				
	Charring rate	EN 1995-1-2; Table 3.1 <sup>1</sup>			
	tightly butted boards acc. to Tab. A.2.1 for plywood <sup>2</sup>		$\beta_0 = 0.65$ mm/min $\beta_n = 0.8$ mm/min		
for LVL	$\beta_0 = 1,0$ mm/min $\beta_n = 0,65$ mm/min $\beta_n = 0,7$ mm/min				
for OSB <sup>2</sup> and single-layered solid wood panels <sup>2</sup>	$\beta_0 = 0,9$ mm/min				

<sup>1</sup> Charring rates apply to the external lamella directly exposed to the fire.

<sup>2</sup> The values apply to a characteristic density of 450 kg/m<sup>3</sup> and a panel thickness of 20 mm; see 3.4.2(9) for other thicknesses and densities.

Derix X-LAM

Essential requirements of the cross laminated timber

Annex 3

**Table A.3.1: continued**

3	<b>Hygiene, health and the environment</b>		
	Water vapour resistance factor $\mu$	no performance assessed	
	Content of dangerous substances	EAD 130005-00-0340	See clause 3
4	<b>Safety in use</b>		
	Impact resistance	Soft body resistance is assumed to be fulfilled for walls with a minimum of 3 layers and minimum thickness of 60 mm.	
5	<b>Protection against noise</b>		
	Airbourne sound insul.	No performance assessed	
	Impact sound insulation	No performance assessed	
	Sound absorption	No performance assessed	
6	<b>Energy economy and heat retention</b>		
	Thermal conductivity $\lambda$	EN ISO 10456	0.12 W/(m·K)
	Air tightness	EN 12114	Class 4 acc. to EN 12207
	Thermal inertia $c_p$	EN ISO 10456	1600 J/(kg·K)

Derix X-LAM

Essential requirements of the cross laminated timber

Annex 3

**Table A.3.2: Characteristic shear strength  $f_{v,k}$  calculated with the gross cross section (for mechanical actions in plane of the cross laminated timber)**

Element Thickness in mm	Number of layers	Thickness of individual layers in mm (written in <b>bold</b> characters for longitudinal layers)										$f_{v,k}^{(1)}$ in N/mm <sup>2</sup>	
60	3	<b>20</b>	20	<b>20</b>									<b>2.7</b>
80	3	<b>30</b>	20	<b>30</b>									<b>2.0</b>
90	3	<b>30</b>	30	<b>30</b>									<b>2.6</b>
100	3	<b>40</b>	20	<b>40</b>									<b>1.6</b>
110	3	<b>40</b>	30	<b>40</b>									<b>2.1</b>
120	3	<b>40</b>	40	<b>40</b>									<b>2.2</b>
100	5	<b>20</b>	20	<b>20</b>	20	<b>20</b>							<b>3.2</b>
110	5	<b>20</b>	20	<b>30</b>	20	<b>20</b>							<b>2.9</b>
120	5	<b>20</b>	30	<b>20</b>	30	<b>20</b>							<b>3.4</b>
130	5	<b>30</b>	20	<b>30</b>	20	<b>30</b>							<b>2.5</b>
140	5	<b>40</b>	20	<b>20</b>	20	<b>40</b>							<b>2.3</b>
150	5	<b>30</b>	30	<b>30</b>	30	<b>30</b>							<b>3.1</b>
160	5	<b>40</b>	20	<b>40</b>	20	<b>40</b>							<b>2.0</b>
170	5	<b>40</b>	30	<b>30</b>	30	<b>40</b>							<b>2.8</b>
180	5	<b>40</b>	30	<b>40</b>	30	<b>40</b>							<b>2.6</b>
200	5	<b>40</b>	40	<b>40</b>	40	<b>40</b>							<b>2.7</b>
140	7	<b>20</b>	20	<b>20</b>	20	<b>20</b>	20	<b>20</b>					<b>3.4</b>
160	7	<b>30</b>	20	<b>20</b>	20	<b>20</b>	20	<b>30</b>					<b>3.0</b>
180	7	<b>30</b>	20	<b>30</b>	20	<b>30</b>	20	<b>30</b>					<b>2.7</b>
200	7	<b>30</b>	30	<b>30</b>	20	<b>30</b>	30	<b>30</b>					<b>3.2</b>
220	7	<b>40</b>	20	<b>40</b>	20	<b>40</b>	20	<b>40</b>					<b>2.2</b>
240	7	<b>40</b>	20	<b>40</b>	40	<b>40</b>	20	<b>40</b>					<b>2.7</b>
260	7	<b>40</b>	30	<b>40</b>	40	<b>40</b>	30	<b>40</b>					<b>2.8</b>
280	7	<b>40</b>	40	<b>40</b>	40	<b>40</b>	40	<b>40</b>					<b>2.9</b>
230	9	<b>30</b>	20	<b>30</b>	20	<b>30</b>	20	<b>30</b>	20	<b>30</b>			<b>2.8</b>
250	9	<b>40</b>	20	<b>30</b>	20	<b>30</b>	20	<b>30</b>	20	<b>40</b>			<b>2.6</b>
270	9	<b>30</b>	30	<b>30</b>	30	<b>30</b>	30	<b>30</b>	30	<b>30</b>			<b>3.5</b>
280	9	<b>40</b>	20	<b>40</b>	20	<b>40</b>	20	<b>40</b>	20	<b>40</b>			<b>2.3</b>
290	9	<b>40</b>	30	<b>30</b>	30	<b>30</b>	30	<b>30</b>	30	<b>40</b>			<b>3.2</b>
310	9	<b>40</b>	30	<b>40</b>	30	<b>30</b>	30	<b>40</b>	30	<b>40</b>			<b>3.0</b>
320	9	<b>40</b>	30	<b>40</b>	30	<b>40</b>	30	<b>40</b>	30	<b>40</b>			<b>2.9</b>
360	9	<b>40</b>	40	<b>40</b>	40	<b>40</b>	40	<b>40</b>	40	<b>40</b>			<b>3.0</b>
370	11	<b>40</b>	20	<b>40</b>	30	<b>40</b>	30	<b>40</b>	30	<b>40</b>	20	<b>40</b>	<b>2.8</b>
390	11	<b>40</b>	30	<b>40</b>	30	<b>40</b>	30	<b>40</b>	30	<b>40</b>	30	<b>40</b>	<b>3.0</b>
190	7	<b>30</b>	<b>30</b>	20	<b>30</b>	20	<b>30</b>	<b>30</b>					<b>1.7</b>
210	7	<b>30</b>	<b>30</b>	30	<b>30</b>	30	<b>30</b>	<b>30</b>					<b>2.2</b>
230	7	<b>30</b>	<b>30</b>	40	<b>30</b>	40	<b>30</b>	<b>30</b>					<b>2.0</b>
240	7	<b>40</b>	<b>40</b>	20	<b>40</b>	20	<b>40</b>	<b>40</b>					<b>1.3</b>
260	7	<b>40</b>	<b>40</b>	30	<b>40</b>	30	<b>40</b>	<b>40</b>					<b>1.8</b>
280	7	<b>40</b>	<b>40</b>	40	<b>40</b>	40	<b>40</b>	<b>40</b>					<b>1.9</b>
240	9	<b>30</b>	<b>30</b>	20	<b>30</b>	20	<b>30</b>	20	<b>30</b>	<b>30</b>			<b>2.0</b>
270	9	<b>30</b>	<b>30</b>	30	<b>30</b>	30	<b>30</b>	30	<b>30</b>	<b>30</b>			<b>2.6</b>

Derix X-LAM

Essential requirements of the cross laminated timber

Annex 3

**Table A.3.2 (continued)**

Element Thickness in mm	Number of layers	Thickness of individual layers in mm (written in <b>bold</b> characters for longitudinal layers)											$f_{v,k}^{1)}$ in N/mm <sup>2</sup>
300	9	<b>40</b>	<b>40</b>	20	<b>40</b>	20	<b>40</b>	20	<b>40</b>	<b>40</b>			<b>1.6</b>
330	9	<b>40</b>	<b>40</b>	30	<b>40</b>	30	<b>40</b>	30	<b>40</b>	<b>40</b>			<b>2.1</b>
360	9	<b>40</b>	<b>40</b>	40	<b>40</b>	40	<b>40</b>	40	<b>40</b>	<b>40</b>			<b>2.2</b>
290	11	<b>30</b>	<b>30</b>	20	<b>30</b>	20	<b>30</b>	20	<b>30</b>	20	<b>30</b>	<b>30</b>	<b>2.2</b>
310	11	<b>30</b>	<b>30</b>	20	<b>30</b>	30	<b>30</b>	30	<b>30</b>	20	<b>30</b>	<b>30</b>	<b>2.6</b>
360	11	<b>40</b>	<b>40</b>	20	<b>40</b>	20	<b>40</b>	20	<b>40</b>	20	<b>40</b>	<b>40</b>	<b>1.8</b>
400	11	<b>40</b>	<b>40</b>	30	<b>40</b>	30	<b>40</b>	30	<b>40</b>	30	<b>40</b>	<b>40</b>	<b>2.4</b>
60	3	20	<b>20</b>	20									<b>2.7</b>
70	3	20	<b>30</b>	20									<b>2.9</b>
80	3	30	<b>20</b>	30									<b>2.0</b>
90	3	30	<b>30</b>	30									<b>2.6</b>
100	3	30	<b>40</b>	30									<b>2.4</b>
110	3	40	<b>30</b>	40									<b>2.1</b>
120	3	40	<b>40</b>	40									<b>2.2</b>
100	5	20	<b>20</b>	20	<b>20</b>	20							<b>3.2</b>
110	5	20	<b>20</b>	30	<b>20</b>	20							<b>2.9</b>
120	5	20	<b>30</b>	20	<b>30</b>	20							<b>3.4</b>
130	5	30	<b>20</b>	30	<b>20</b>	30							<b>2.5</b>
140	5	30	<b>30</b>	20	<b>30</b>	30							<b>3.1</b>
150	5	30	<b>30</b>	30	<b>30</b>	30							<b>3.1</b>
160	5	40	<b>20</b>	40	<b>20</b>	40							<b>2.0</b>
170	5	30	<b>40</b>	30	<b>40</b>	30							<b>2.8</b>
180	5	40	<b>30</b>	40	<b>30</b>	40							<b>2.6</b>
190	5	40	<b>40</b>	30	<b>40</b>	40							<b>2.6</b>
200	5	40	<b>40</b>	40	<b>40</b>	40							<b>2.7</b>

<sup>1)</sup> Values apply to a minimum board width of: 120 mm for a board thickness of 20 mm;  
140 mm for a board thickness of 30 mm resp. 160 mm for a board thickness of 40 mm.

For elements with lay-ups differing from those given in Table A.3.2 the shear strength for the calculation with the gross cross section may be calculated by :

$$f_{v,k} = \min \left\{ \begin{array}{l} 3,5 \\ 8 \cdot \frac{D_{net}}{D} \\ f_{v,tor,k} \cdot \frac{(n-1)(a^2 + b^2)}{6 D b} \end{array} \right. \quad \text{in N/mm}^2$$

- with
- D = total thickness of the element (sum of longitudinal and cross layers)
  - D<sub>net</sub> = total thickness of longitudinal or cross layers within the element, the smaller value applies
  - n = number of layers within the element, neighbouring layers with parallel lamellas shall be considered as one layer
  - a, b = width of the boards in the longitudinal or cross layers, where b > a  
(If a and b unknown, the minimum value must be applied for a and b.)
  - f<sub>v,tor,k</sub> = char. torsional shear strength acc. to Tab. A.3.1, Annex 3

Derix X-LAM

Essential requirements of the cross laminated timber

Annex 3

**Table A.3.3 Mechanical properties of the solid wood slab elements (examples)**

a) X-LAM solid wood slab elements made from laminations of strength class C24 according EN 338

<b>1. Actions perpendicular to the solid wood slab</b>		
<b>Property</b>	<b>Symbol</b>	<b>Characteristic value</b>
Bending strength	$f_{m,k}$	$k_f \cdot 24 \text{ MPa}^{1)}$
Compressive strength	$f_{c,90,k}$	2.5 MPa
Shear strength perpendicular to the grain of the boards (rolling shear strength)	$f_{r,k}$	1.1 MPa
Modulus of elasticity parallel to the grain of the boards	$E_{0,\text{mean}}$	11 000 MPa
Modulus of elasticity perpendicular to the grain of the boards	$E_{90,\text{mean}}$	370 MPa
Shear modulus parallel to the grain of the boards	$G_{\text{mean}}$	690 MPa
Shear modulus perpendicular to the grain of the boards (rolling shear modulus)	$G_{r,\text{mean}}$	50 MPa
<b>2. Actions in plane of the solid wood slab</b>		
<b>Property</b>	<b>Symbol</b>	<b>Characteristic value</b>
Bending strength	$f_{m,k}$	$k_f \cdot 24 \text{ MPa}^{1)}$
Compressive strength parallel to the grain of the boards	$f_{c,0,k}$	21 MPa
Tensile strength strength parallel to the grain of the boards	$f_{t,0,k}$	14.5 MPa
Tensile strength perpendicular to the grain of the boards	$f_{t,90,k}$	0.4 MPa
Shear strength calculated with the gross cross section	$f_{v,k}$	as given in Table A.3.2
Modulus of elasticity parallel to the grain of the boards	$E_{0,\text{mean}}$	11 000 MPa
Shear modulus parallel to the grain of the boards	$G_{\text{mean}}$	500 MPa
<b>3. Connections with metal fasteners</b>		
<b>Property</b>	<b>Symbol</b>	<b>Mean value</b>
Density	$\rho_{\text{mean}}$	420 kg/m <sup>3</sup>

<sup>1)</sup>  $k_f$  see Annex 4

Derix X-LAM

Essential requirements of the cross laminated timber (example)

Annex 3

b) X-LAM solid wood slab elements made from laminations of strength class C30 according EN 338

<b>1. Actions perpendicular to the solid wood slab</b>		
<b>Property</b>	<b>Symbol</b>	<b>Characteristic value</b>
Bending strength	$f_{m,k}$	$k_t \cdot 30 \text{ MPa}^{1)}$
Compressive strength	$f_{c,90,k}$	2.7 MPa
Shear strength perpendicular to the grain of the boards (rolling shear strength)	$f_{r,k}$	1.1 MPa
Modulus of elasticity parallel to the grain of the boards	$E_{0,mean}$	12 000 MPa
Modulus of elasticity perpendicular to the grain of the boards	$E_{90,mean}$	400 MPa
Shear modulus parallel to the grain of the boards	$G_{mean}$	750 MPa
Shear modulus perpendicular to the grain of the boards (rolling shear modulus)	$G_{R,mean}$	50 MPa
<b>2. Actions in plane of the solid wood slab</b>		
<b>Property</b>	<b>Symbol</b>	<b>Characteristic value</b>
Bending strength	$f_{m,k}$	$k_t \cdot 30 \text{ MPa}^{1)}$
Compressive strength parallel to the grain of the boards	$f_{c,0,k}$	24 MPa
Tensile strength strength parallel to the grain of the boards	$f_{t,0,k}$	19 MPa
Tensile strength perpendicular to the grain of the boards	$f_{t,90,k}$	0.4 MPa
Shear strength calculated with the gross cross section	$f_{v,k}$	as given in Table A.3.2
Modulus of elasticity parallel to the grain of the boards	$E_{0,mean}$	12 000 MPa
Shear modulus parallel to the grain of the boards	$G_{mean}$	540 MPa
<b>3. Connections with metal fasteners</b>		
<b>Property</b>	<b>Symbol</b>	<b>Mean value</b>
Density	$\rho_{mean}$	460 kg/m <sup>3</sup>

<sup>1)</sup>  $k_t$  see Annex 4

Derix X-LAM

Essential requirements of the cross laminated timber (example)

Annex 3

## Annex 4 Recommendations for the design of the elements

### A.4.1 Mechanical actions perpendicular to the element's plane

Stress distribution within the element shall be calculated taking into account the shear deformation of the cross layers.

For simply supported cross laminated timber elements with up to 5 layers the stress distribution may be calculated according to EN 1995-1-1, Annex B as mechanically jointed beam where the value  $s_i/K_i$  is substituted by  $\bar{h}_i/(G_{r,mean} \cdot b)$

with  $\bar{h}_i$  = thickness of the cross layer  
 $G_{R,mean}$  = 50 N/mm<sup>2</sup> shear modulus of the cross layer  
 b = width of the cross layer.

(Design according to the theory of flexible bonded beams see A.4.3)

For cross laminated timber with more than 5 layers numerical solutions shall be used offered by computer programs taking into account the shear deformation of the cross layers.

For the design of cross laminated timber the characteristic strength and stiffness values shall be taken from Annex 3.

For the bending design only the stresses at the edges of the boards are decisive.

For the calculation of the cross-section values according A.4.3 the boards and wood-based panels in load-bearing direction may taken into account.

For the verification of the bending strength the design bending strength value of a layer of boards may be multiplied by a system strength factor factor  $k_{\ell}$ :

$$k_{\ell} = \min \begin{cases} 1 + 0.025 \cdot n \\ 1.2 \end{cases}$$

with n = number of boards within a layer

Tension loads perpendicular to the plane of the element shall be avoided.

### A.4.2 Mechanical actions in plane of the cross laminated timber

Stress distribution within the element shall be calculated by taking into account only the boards which are oriented in the direction of the actions.

Shear stresses may be calculated with the total thickness of the element.

For the design of cross laminated timber elements made of layers of softwood the characteristic strength and stiffness values of the layers of softwood shall be taken from Annex 3.

For the design of cross laminated timber elements with layers of wood-based panels either the characteristic strength and stiffness values of the layers of softwood shall be used or the corresponding values of the wood-based panels may taken into account.

For the verification of the bending strength the design bending strength value of a layer of boards may be multiplied by a system strength factor  $k_{\ell}$ :

$$k_{\ell} = \min \begin{cases} 1 + 0.025 \cdot n \\ 1.2 \end{cases}$$

with n = number of longitudinal layers.

Derix X-LAM

Design considerations

Annex 4



#### A.4.3 Design according to the theory of flexible bonded beams

The calculation of elements with up to five layers can be performed using the theory of flexible bonded beams as described in EN 1995-1-1.

To consider deformations due to shear the factor  $s_i/K_i$  according to the standard is substituted by the factor  $\bar{h}_i/(G_{r,mean} \cdot b)$ . (Note: The symbols have been taken from EN 1995-1-1 and may partly differ from the symbols in this ETA.)

The effective moment of inertia is calculated by:

$$I_{ef} = \sum_{i=1}^3 (l_i \cdot \gamma_i \cdot A_i \cdot a_i^2) \quad \text{with} \quad A_i = b_i \cdot h_i; \quad l_i = \frac{b_i \cdot h_i^3}{12}$$

$$\gamma_1 = \frac{1}{1 + \frac{\pi^2 \cdot E_0 \cdot A_1 \cdot \bar{h}_1}{G_{r,mean} \cdot b \cdot l^2}}; \quad \gamma_2 = 1; \quad \gamma_3 = \frac{1}{1 + \frac{\pi^2 \cdot E_0 \cdot A_3 \cdot \bar{h}_2}{G_{r,mean} \cdot b \cdot l^2}}$$

$$a_1 = \left( \frac{h_1}{2} + \bar{h}_1 + \frac{h_2}{2} \right) - a_2; \quad a_3 = \left( \frac{h_2}{2} + \bar{h}_2 + \frac{h_3}{2} \right) + a_2$$

$$a_2 = \frac{\gamma_1 \cdot A_1 \cdot \left( \frac{h_1}{2} + \bar{h}_1 + \frac{h_2}{2} \right) - \gamma_3 \cdot A_3 \cdot \left( \frac{h_2}{2} + \bar{h}_2 + \frac{h_3}{2} \right)}{\sum_{i=1}^3 (\gamma_i \cdot A_i)}$$

The verification of the bending performance is done by determination of the bending stress at the boundary of the boards (The bending stress in the middle of the boards may for board layers remain unconsidered. For layers of wood-based panels the verification of the bending stress in the middle of the panel shall be performed.):

$$\sigma_{m,r,i,d} = \pm \frac{M_d}{I_{ef}} \cdot \left( \gamma_i \cdot a_i + \frac{h_i}{2} \right) \leq f_{m,d}$$

The verification of the shear performance is done by determination of the shear stress in the decisive plane:

$$\tau_{v,d} = \frac{V_d \cdot \gamma_i \cdot S_i}{I_{ef} \cdot b} \leq f_{R,d}$$

Legend:

- $h_i$  = thickness of the layer  $i$  parallel to the direction of load transfer [mm]
- $\bar{h}_i$  = thickness of the layer  $i$  perpendicular to the direction of load transfer [mm]
- $b$  = width of the element [mm]
- $n$  = number of layers
- $l$  = span width [mm]
- $I_{ef}$  = effective moment of inertia [Nmm<sup>2</sup>]
- $G_{r,mean}$  = rolling shear modulus [N/mm<sup>2</sup>]
- $E_0$  = modulus of elasticity parallel to the grain of the boards [N/mm<sup>2</sup>]

Derix X-LAM

Design considerations

Annex 4

## Annex 5 Fasteners (informative)

### A.5 Recommendations for the design of the fasteners

#### A.5.1 General

The determination of characteristic values of the load-bearing capacity of fasteners in the element shall be carried out according to EN 1995-1-1 or acc. to an European Technical Approval or Assessment which has been granted for the relevant fastener as for softwood or for glued laminated timber. For the calculation according to European regulations national provisions may apply.

Wide faces are the surfaces of the element parallel to the plane of the element consisting of the surface of the outer layers.

Narrow faces are the lateral and the cross grain board surfaces perpendicular to the plane of the element.

Only fasteners according to EN 1995-1-1 or a European Technical Approval or Assessment or according to national regulations may be used.

Fasteners in the lateral surfaces of wood based panels used as cover layers are not allowed.

If the position of the fasteners in the narrow faces is not clearly defined (end grain, gaps between the single boards, etc.), then the most unfavourable case is to be assumed.

The grain direction of the cover layers governs the minimum spacings of the fasteners as well as the embedding strength is. For the minimum spacings, minimum thicknesses, minimum layer thicknesses and minimum penetration length of fasteners, see Annex A.5.6.

Additional please note the following:

#### A.5.2 Nails

The nails must be at least 4.0 mm in diameter.

The effective number of nails  $n_{ef}$  for outer layers with a thickness of  $\leq 40$  mm may be set equal to the actual number  $n$ . For outer layers with a thickness  $> 40$  mm, the effective number of nails  $n_{ef}$  according to EN 1995-1-1 (8.3.1.1) shall be used.

#### Wide faces

The characteristic load-carrying capacity of laterally loaded nails in the wide faces is to be determined according to EN 1995-1-1 in conjunction with DIN EN 1995-1-1/NA. Decisive for the minimum spacing is the direction of the grain of the cover layers. The characteristic density of the cover layers is decisive for the density.

#### Narrow faces

Nails in the narrow faces of the elements shall not be considered as load-bearing.

Derix X-LAM

Fasteners

Annex 5

#### Axially loaded nails (pull-out)

Only profiled nails may be used when pulling out. The characteristic withdrawal capacity in the wide faces may be assumed to be:

$$F_{ax,Rk} = 14 \cdot d^{0.6} \cdot l_{ef} \cdot k_d \quad \text{in N}$$

where

$d$  = outer diameter of the nail (threaded part)

$l_{ef}$  = penetration length of the threaded part

The following conditions should be fulfilled:

- at least two nails in a connection
- diameter of the threaded part  $d \geq 4$  mm
- penetration length of the threaded part  $l_{ef} \geq 8 d$
- characteristic point side withdrawal parameter  $f_{ax,k} \geq 50 \cdot 10^{-6} \cdot \rho_k^2$   
with  $\rho_k$  = characteristic value of density ( $\text{kg/m}^3$ ); max.  $500 \text{ kg/m}^3$

#### **A.5.3 Screws**

As decisive diameter of the screws the outer diameter of the thread applies.

Screws loaded perpendicular to their axis in the wide faces should have a diameter of at least 4 mm, screws in the narrow faces of at least 8 mm, if the edge of a board is not considered construction edge. Penetration depth  $l_{ef} < 4d$  may not be taken into account.

The effective number of screws  $n_{ef}$  for outer layers with a thickness of  $\leq 40$  mm may be set equal to the actual number  $n$ . For outer layers with a thickness  $> 40$  mm, the effective number of screws  $n_{ef}$  according to EN 1995-1-1 (8.3.1.1) shall be used.

#### Wide faces

The load direction must be perpendicular to the screw axis and parallel to the wide face of the cross laminated timber.

The characteristic load bearing capacity of laterally loaded screws in the wide faces can be calculated according to EN 1995-1-1. The regulations for wood screw connections in solid timber shall be used. As density the characteristic value of the wood of the cover layer shall be used. In case the penetration depth of the screw is at least as large as the thickness of the three outer layers, the characteristic density can be assumed with  $\rho_k = 400 \text{ kg/m}^3$ .

The angle between direction of the force and direction of the grain might have to taken into account.

For angles between  $45^\circ \leq \alpha \leq 90^\circ$  between the screw axis and the direction of the grain of the cover layer, the characteristic values for  $\alpha = 90^\circ$  can be assumed if only the dimension perpendicular to the wide faces is taken into account as the penetration depth.

Decisive for the minimum spacing is the direction of the grain of the cover layers.

#### Narrow faces

The load direction must be perpendicular to the screw axis and parallel to the narrow face of the cross laminated timber.

Irrespective of the arrangement of a screw in the narrow face (which means under angles  $0^\circ \leq \alpha \leq 90^\circ$  between screw axis and direction of the grain) the characteristic value of the embedment strength can be assumed to:

$$f_{h,k} = 20 \cdot d^{-0.5} \quad \text{in N/mm}^2$$

with

$d$  = nominal diameter of the screw in mm,

Derix X-LAM

Fasteners

Annex 5

Note:

If a component of the force is oriented perpendicular to the wide face, there is the risk of a failure due to tension perpendicular to the grain. In case the ratio  $D_e/D$  is not over 0.7, a calculation due to tension perpendicular to the grain is advised. In this case, it is recommended to prevent this failure by reinforcing with fully threaded screws parallel to the narrow surface (see Figure).

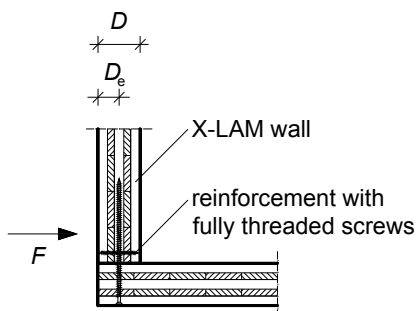

Withdrawal (pull-out), wide and narrow faces

The characteristic withdrawal capacity for self-tapping screws in the wide sides or in the narrow sides of cross laminated timber may be calculated

$$F_{ax,Rk} = \sum_{i=1}^n f_{ax,i,k} \cdot \ell_{ef,i} \cdot d \quad \text{in N}$$

where

- $d$  = Outer thread diameter of the screw, with  $d \geq 6$  mm for screws in the wide sides of cross laminated timber and  $d \geq 8$  mm for screws in the narrow sides of cross laminated timber
- $f_{ax,i,k}$  = Characteristic withdrawal parameter of layer  $i$  depending on the characteristic density  $\rho_{k,i}$  and the angle  $\alpha_i$  between screw axis and grain direction of layer  $i$
- $\ell_{ef,i}$  = Penetration length of the threaded part in layer  $i$
- $n$  = Number of penetrated layers

The following conditions should be fulfilled:

- Penetration length of the threaded part  $\ell_{ef,i} \geq 4 d$

For the design of axially loaded screws in cross laminated timber only threaded parts with an angle  $\alpha \geq 30^\circ$  between screw axis and grain direction may be taken into account.

Screws oriented parallel to the plane side of the cross laminated timber should be completely arranged within one layer. The outer diameter of the threaded part should not exceed the thickness of the layer the screw is arranged in.

The characteristic pull-through strength of the screw head for solid timber may be used, depending on the characteristic density of the layer at the head side of the screw.

Derix X-LAM

Fasteners

Annex 5

#### A.5.4 Split ring, shear plate and toothed-plate connectors

Split ring connectors and toothed-plate connectors may neither be arranged in the wide sides of wood based panels nor in the narrow sides of Derix X-Lam members containing wood-based panels.

##### Wide faces

The characteristic load-carrying capacity of split ring, shear plate and toothed-plate connectors in the wide faces of cross laminated timber may be calculated according to EN 1995-1-1 for an angle between force and grain direction of  $\alpha = 0^\circ$  regardless of the actual angle between the force and grain direction of the cover layers.

When inserting in the wide faces a minimum layer thickness of 20 mm must be maintained.

##### Narrow faces

For split ring and shear plate connectors in the narrow faces of the cross laminated timber the regulations for connections with split ring connectors in the end grain of timber members may be applied.

#### A.5.5 Connections with dowels and bolts

##### Wide faces

The characteristic load-carrying capacity of dowelled or bolted connections in the wide faces is to be determined with the embedding strength according to the following equation:

$$f_{h,\alpha,k} = \frac{32 \cdot (1 - 0.015 \cdot d)}{1.1 \cdot \sin^2 \alpha + \cos^2 \alpha} \quad \text{N/mm}^2$$

with

d fastener diameter in mm

$\alpha$  angle between force and grain direction of the cover layer

Decisive for the calculation of the embedding strength is the grain direction of the cover layers.

For dowels and bolts connections with a diameter  $\geq 10$  mm,  $n_{ef} = n$  may be assumed.

##### Narrow faces

The characteristic load-carrying capacity of dowelled or bolted connections in the narrow faces is to be determined with the embedding strength according to the following equation:

$$f_{h,k} = 9 \cdot (1 - 0.017 \cdot d) \quad \text{N/mm}^2$$

with

d fastener diameter in mm

##### Note:

For actions perpendicular to the plane of the cross laminated timber the possibility of splitting caused by the tension force component perpendicular to the grain, shall be taken into account. Connections with ratios  $D_e/D \leq 0.7$  should be reinforced with fully threaded screws.

Derix X-LAM

Fasteners

Annex 5

### A.5.6 Minimum spacings of fasteners

#### A.5.6.1 Minimum spacings of fasteners in the wide faces

Minimum spacings – parallel and perpendicular to grain

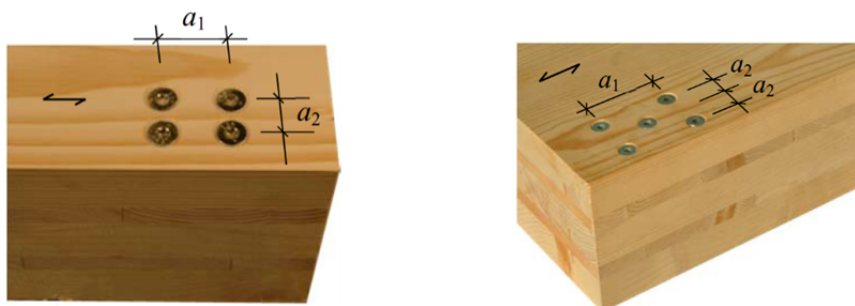

Edge and end distances

loaded end  $a_{3,t}$

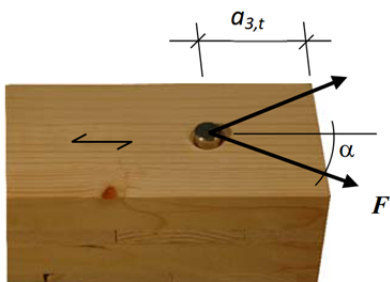

unloaded end  $a_{3,c}$

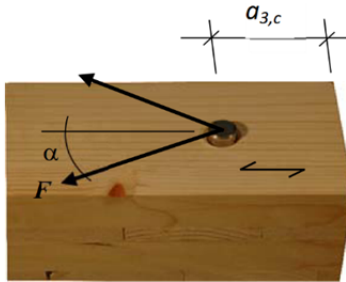

unloaded edge  $a_{4,c}$

loaded edge  $a_{4,t}$

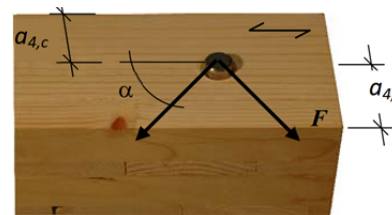
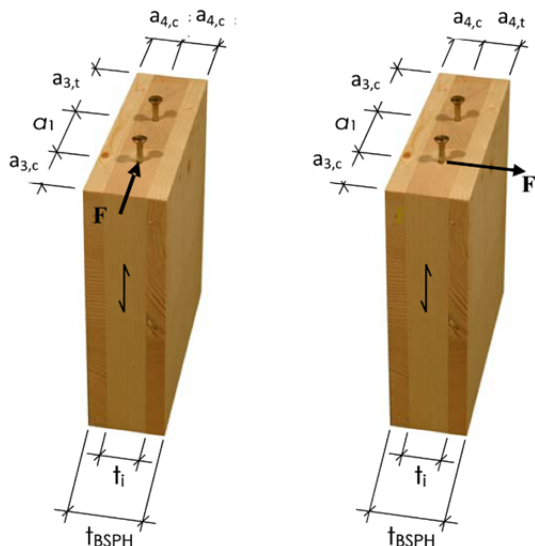

**Table A.5.1:** Minimum spacings of fasteners in the wide faces

fastener	$a_1$	$a_2$	$a_{3,t}$	$a_{3,c}$	$a_{4,t}$	$a_{4,c}$
screws <sup>1)</sup>	$4 \cdot d$	$2.5 \cdot d$	$6 \cdot d$	$6 \cdot d$	$6 \cdot d$	$2.5 \cdot d$
nails	$(3+3 \cdot \cos\alpha) \cdot d$	$3 \cdot d$	$(7+3 \cdot \cos\alpha) \cdot d$	$6 \cdot d$	$(3+4 \cdot \sin\alpha) \cdot d$	$3 \cdot d$
dowels	$(3+2 \cdot \cos\alpha) \cdot d$	$3 \cdot d$	$5 \cdot d$	$4 \cdot d \cdot \sin\alpha$ min. $3 \cdot d$	$3 \cdot d$	$3 \cdot d$
bolts	$(3+2 \cdot \cos\alpha) \cdot d$ min. $4 \cdot d$	$4 \cdot d$	$5 \cdot d$	min. $4 \cdot d$	$3 \cdot d$	$3 \cdot d$
$\alpha$ <sup>1)</sup>	angle between force and grain direction of the cover layer self-tapping screws					

### A.5.6.2 Minimum spacings, minimum thicknesses, minimum layer thicknesses und minimum penetration lengths of fasteners in the narrow faces

The minimum spacings in the narrow faces are independent of the angle between fastener axis and grain direction.



**Table A.5.2:** Minimum spacings of fasteners in the narrow faces

	$a_1$	$a_2$	$a_{3,t}$	$a_{3,c}$	$a_{4,t}$	$a_{4,c}$
screws <sup>1)</sup>	10·d	3·d	12·d	7·d	6·d	3·d
dowels	4·d	3·d	5·d	3·d	5·d	3·d
bolts	4·d	4·d	5·d	4·d	5·d	3·d
<sup>1)</sup> self-tapping screws						

**Table A.5.3:** Requirements for fasteners in the narrow faces of cross laminated timber

fastener	Minimum thickness of the cross laminated timber	Minimum thickness of the relevant layer	Minimum penetration length of the fastener $t_1$ oder $t_2$ <sup>*)</sup>
	$t_{BSPH}$ in mm	$t_i$ in mm	in mm
screws <sup>1)</sup>	10·d	d > 8 mm: 3·d d ≤ 8 mm: 2·d	10·d
dowels bolts	6·d	d	5·d
<sup>*)</sup> $t_1$ Minimum penetration length of the fastener in side members (member to be connected) $t_2$ Minimum penetration length of the fastener in middle members (cross laminated timber element) <sup>1)</sup> self-tapping screws			

## Annex 6 Design of CLT beams loaded in plane direction (informative)

### A.6.1 Noched CLT beams

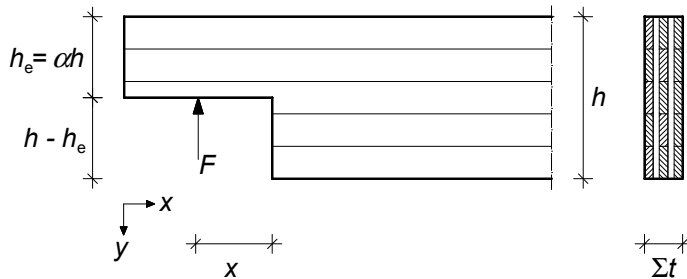

The characteristic value of the load carrying capacity of a notched end of a CLT beam is:

$$V_{Rk} = \min \left\{ \begin{array}{l} \frac{2 \cdot f_{v,k} \cdot h_e \cdot \sum t}{3} \\ \frac{f_{m,k} \cdot h_e^2 \cdot \sum t_x}{6 \cdot x} \\ \frac{f_{t,0,k} \cdot (h - h_e) \cdot \sum t_y}{5.2 \cdot [3(1-\alpha)^2 - 2(1-\alpha)^3]} \\ \frac{n_{CA}}{\frac{3 \cdot k_1 \left( \frac{1}{b \cdot h} - \frac{b}{h^3} \right) + \frac{2.6 \cdot (3(1-\alpha)^2 - 2(1-\alpha)^3)}{f_{r,k} \cdot (h - h_e)^2}} \end{array} \right.$$

#### Legend:

- $f_{v,k}$  characteristic shear strength in plane according to Tab. A.3.1, Annex 3;
- $f_{m,k}$  characteristic bending strength of laminations in longitudinal layers (x-direction);
- $f_{t,0,k}$  characteristic tensile strength parallel to the grain of the laminations in transversal layers (y-direction);
- $f_{v,tor,k}$  characteristic torsional shear strength of the glued area of crosswise bonded laminations according to Tab. A.3.1, Annex 3;
- $f_{r,k}$  characteristic rolling shear strength according to Tab. A.3.1, Annex 3;
- $h_e$  reduced height of the noched beam;
- $h$  total height of the noched beam;
- $\alpha = h_e/h$ ;
- $\sum t_x$  total thickness of longitudinal layers within the element;
- $\sum t_y$  total thickness of transversal layers within the element;
- $\sum t$  element thickness (sum of longitudinal and transversal layers within the element);
- $x$  distance between the corner of the notch and the centre of the support;
- $b$  smallest width of the laminations;
- $n_{CA}$  number of crossing areas within the element thickness;
- $k_1 = 0.9 \cdot (h/h_e)^{k_p}$ ;
- $k_p = 1.45 \cdot (x/h)^{2/3}$

Derix X-LAM

Design of CLT beams loaded in plane direction

Annex 6



**A.6.2 CLT beams with rectangular holes**

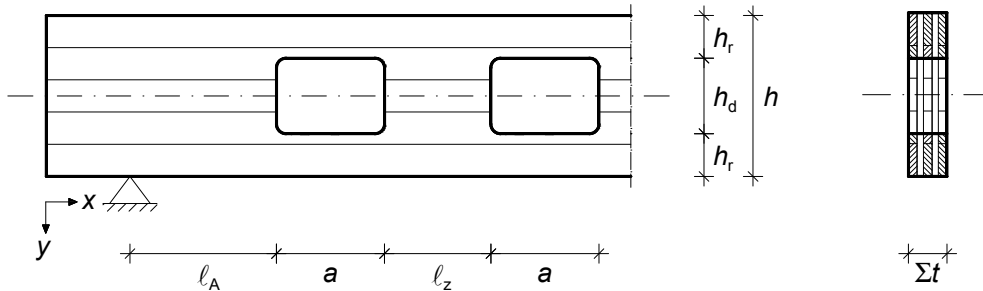

The following conditions for holes located in the middle of beam height with  $l_z \geq \max(a, h/2)$  loaded in plane direction must be fulfilled:

$$\sigma_{m,d} = \frac{6 \cdot M_{Ed} \cdot h}{\sum t_x \cdot (h^3 - h_d^3)} + \frac{3 \cdot V_{Ed} \cdot a}{2 \cdot \sum t_x \cdot h_r^2} \leq f_{m,d} = f_{m,k} \cdot \frac{k_{mod}}{\gamma_M}$$

$$\sigma_{t,0,d} = \frac{2 \cdot F_{t,90,d}}{\sum t_y \cdot b_y} \leq f_{t,0,d} = f_{t,0,k} \cdot \frac{k_{mod}}{\gamma_M}$$

$$\frac{\tau_{tor,d}}{f_{v,tor,d}} + \frac{\max(\tau_{x,d}; \tau_{y,d})}{f_{r,d}} \leq 1 \quad \text{with} \quad f_{v,tor,d} = f_{v,tor,k} \cdot \frac{k_{mod}}{\gamma_M} \quad \text{and} \quad f_{r,d} = f_{r,k} \cdot \frac{k_{mod}}{\gamma_M}$$

**Legend:**

- $M_{Ed}$  design bending moment at the left or right edge of the hole;
- $V_{Ed}$  design shear force at the left or right edge of the hole;
- $f_{m,k}$  characteristic bending strength of the laminations in longitudinal layers (x-direction);
- $f_{t,0,k}$  characteristic tensile strength parallel to the grain of the laminations in transversal layers (y-direction);
- $f_{v,tor,k}$  characteristic torsional shear strength of the glued area of crosswise bonded laminations according to Tab. A.3.1, Annex 3;
- $f_{r,k}$  characteristic rolling shear strength according to Tab. A.3.1, Annex 3;
- $a$  length of the hole,  $a \leq h$ ;
- $l_z$  distance between two adjacent holes,  $l_z \geq \max\{a; 0.5h\}$
- $h$  total height of the beam with hole;
- $h_d$  height of the hole located in the middle of beam height,  $h_d \leq 0.5h$ ;
- $h_r$  remaining height of the beam above and below the hole;
- $\sum t_x$  total thickness of longitudinal layers within the element;
- $\sum t_y$  total thickness of transversal layers within the element;
- $b_y$  width of transversal laminations;

$$F_{t,90,d} = \frac{V_{Ed} \cdot h_d}{4 \cdot h} \left[ 3 - \frac{h_d^2}{h^2} \right] + \frac{0.008 \cdot M_{Ed}}{h_r};$$

$$\tau_{tor,d} = \frac{3 \cdot V_{Ed} \cdot k_2}{n_{CA}} \cdot \left( \frac{1}{b \cdot h} - \frac{b}{h^3} \right) \quad \text{mit} \quad k_2 = 1.81 \cdot \left( \frac{a}{h} \cdot \frac{h_d}{h - h_d} \right) + 1.14;$$

Derix X-LAM

Design of CLT beams loaded in plane direction

Annex 6

$$\tau_{x,d} = \frac{6 \cdot V_{Ed} \cdot t_x \cdot k_3}{\sum t_x \cdot n_A} \cdot \left( \frac{1}{h^2} - \frac{b}{h^3} \right) \quad \text{mit} \quad k_3 = 0.103 \cdot \left( \frac{h_d \cdot a}{b^2} \right) + 1.27 ;$$

$$\tau_{y,d} = \frac{F_{t,90,d}}{n_{CA} \cdot b_y \cdot h_r} ;$$

- $n_{CA}$  number of crossing areas within the element thickness;  
 $b$  smallest width of the laminations;  
 $t_x$  thickness of longitudinal lamination;  
 $n_A$  = 1 for outermost layers in longitudinal direction, otherwise  $n_A = 2$

Derix X-LAM	Annex 6
Design of CLT beams loaded in plane direction	

### A.6.3 CLT beams with transverse connections with axially stressed screws

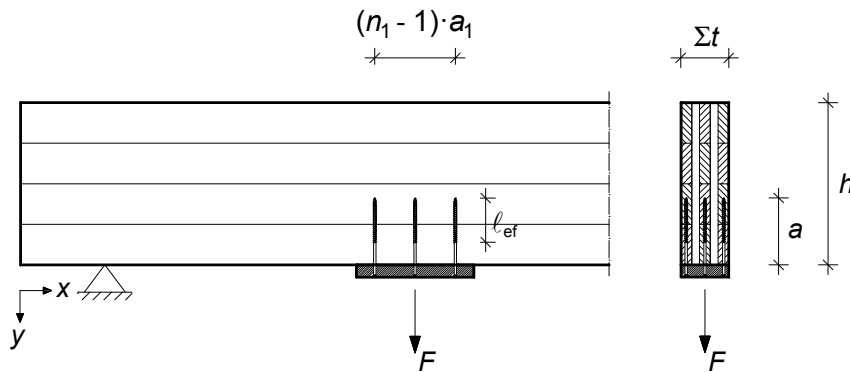

The characteristic value of the load carrying capacity of a transverse connection with axially stressed screws in all longitudinal layers is:

$$F_{90,Rk} = \min \begin{cases} n_{ef} \cdot f_{ax,k} \cdot d \cdot l_{ef} \left( \frac{\rho_k}{\rho_a} \right)^{0.8} \\ \frac{f_{t,0,k} \cdot l_r \cdot \sum t_y}{(1 - 3\alpha^2 + 2\alpha^3)} \\ f_{r,k} \cdot l_r \cdot l_{ef} \cdot n_{CA} \end{cases}$$

#### Legend:

- $f_{ax,k}$  characteristic withdrawal parameter of the screws;
- $d$  outer thread diameter of the screws;
- $l_{ef}$  length of the threaded part of the screws in longitudinal layers;
- $n_{ef}$  effective number of screws according to EN 1995-1-1 equation (8.41);
- $\rho_k$  characteristic density of longitudinal layers;
- $\rho_a$  reference density for  $f_{ax,k}$ ;
- $f_{t,0,k}$  characteristic tensile strength parallel to the grain of the laminations in transversal layers (y-direction);
- $f_{r,k}$  characteristic rolling shear strength according to Tab. A.3.1, Annex 3;
- $l_r = a_1 \cdot n_1$ ;
- $a_1$  spacing of the screws parallel to grain;
- $n_1$  is the number of screws in a row parallel to grain;
- $\sum t_y$  total thickness of transversal layers within the element;
- $\sum t$  element thickness (sum of longitudinal and transversal layers within the element);
- $\alpha = a / h$ ;
- $a$  loaded edge distance of the screw tip;
- $n_{CA}$  number of crossing areas within the element thickness;

Derix X-LAM

Design of CLT beams loaded in plane direction

Annex 6

### A.6.4 Tapered CLT beams

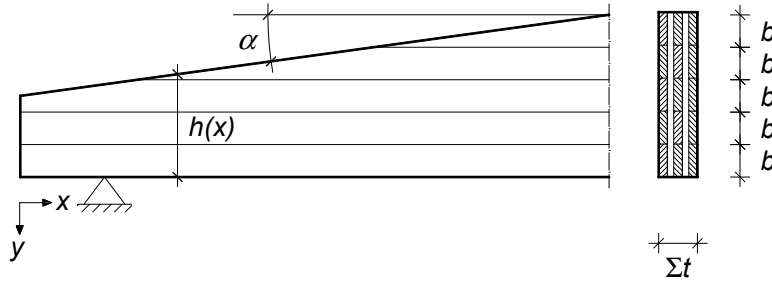

At the outermost fibre of the tapered edge, the stresses should satisfy the expression (6.38) acc. to EN 1995-1-1 with  $k_{m,\alpha}$  as following:

For tensile stresses parallel to the tapered edge:

$$k_{m,\alpha,t} = \frac{1}{\sqrt{1 + \left( \frac{f_{m,xlam,k}}{f_{t,90,xlam,k}} \cdot \tan^2 \alpha \right)^2 + \left( \frac{f_{m,xlam,k}}{f_{v,xlam,k}} \cdot \tan \alpha \right)^2}}$$

For compressive stresses parallel to the tapered edge:

$$k_{m,\alpha,c} = \frac{1}{\sqrt{1 + \left( \frac{f_{m,xlam,k}}{f_{c,90,xlam,k}} \cdot \tan^2 \alpha \right)^2 + \left( \frac{f_{m,xlam,k}}{1.5 \cdot f_{v,xlam,k}} \cdot \tan \alpha \right)^2}}$$

#### Legend:

$f_{i,xlam,k}$  characteristic strength properties in plane of the X-Lam member, related to the element thickness  $\sum t$ , with:

$$f_{m,xlam,k} = \frac{\sum t_x}{\sum t} \cdot f_{m,k};$$

$$f_{c,90,xlam,k} = \min \left\{ f_{c,0,k} \cdot \frac{\sum t_y}{\sum t}; f_{r,k} \cdot \frac{n_{CA} \cdot b}{2 \cdot \sum t} \right\};$$

$$f_{t,90,xlam,k} = \min \left\{ f_{t,0,k} \cdot \frac{\sum t_y}{\sum t}; f_{r,k} \cdot \frac{n_{CA} \cdot b}{2 \cdot \sum t} \right\};$$

$$f_{v,xlam,k} = \min \left\{ \frac{f_{v,lam,k}}{2 \cdot \sum t} \cdot \frac{1}{\frac{1}{f_{v,tor,k}} \cdot \left( 1 - \frac{b^2}{h_x^2} \right) + \frac{2}{f_{r,k}} \cdot \left( \frac{b}{h_x} - \frac{b^2}{h_x^2} \right)} \right\};$$

$\sum t_x$  total thickness of longitudinal layers within the element;

$\sum t_y$  total thickness of transversal layers within the element;

$\sum t$  element thickness (sum of longitudinal and transversal layers within the element);

Derix X-LAM

Design of CLT beams loaded in plane direction

Annex 6

- $b$  width of the boards
- $h_x$  the member height at position  $x$ ;
- $f_{v,lam,k}$  charakteristic shear strength of laminations, here: 3.5 N/mm<sup>2</sup>;
- $f_{v,tor,k}$  charakteristic torsional shear strength of the glued area of crosswise bonded laminations according to Tab. A.3.1, Annex 3;
- $f_{c,0,k}$  charakteristic compressive strength parallel to the grain of the laminations in transversal layers (y-direction);
- $f_{t,0,k}$  charakteristic tensile strength parallel to the grain of the laminations in transversal layers (y-direction);
- $f_{r,k}$  charakteristic rolling shear strength according to Tab. A.3.1, Annex 3;
- $n_{CA}$  number of crossing areas within the element thickness;

Electronic copy of the ETA by DIBt: ETA-11/0189

Derix X-LAM	Annex 6
Design of CLT beams loaded in plane direction	

## Annex 7 References

EAD 130005-00-0304, European Assessment Document for “Solid wood slab element to be used as a structural element in buildings”, Edition March 2015

EN 13986:2014 + A1:2015, Wood-based panels for use in construction - Characteristics, evaluation of conformity and marking

EN 14374:2005, Timber structures - Structural laminated veneer lumber - Requirements

EN 301:2013, Adhesives, phenolic and aminoplastic, for load-bearing timber structures

EN 302-1 bis 4, Adhesives for load bearing timber structures - test methods - Part 1 to 4

EN 15425:2008, Adhesives - One component polyurethane for load bearing timber structures - Classification and performance requirements

EN 1995-1-1:2004 + A1:2008 + A2:2014, Eurocode 5: Design of timber structures - Part 1-1: General - Common rules and rules for buildings

EN 1995-1-2:2004 + AC:2009, Eurocode 5 - Design of timber structures - Part 1-2: General - Structural fire design

EN 338:2016, Structural timber - Strength classes

EN 14081-1:2005+A1:2011, Timber structures - Strength graded structural timber with rectangular cross section - Part 1: General requirements;

EN 14080:2013, Timber structures - Glued laminated timber and glued solid timber - Requirements

EN 13183-2:2002, Moisture content of a piece of sawn timber - Part 2: Estimation by electrical resistance method

EN ISO 10456:2007 + AC:2009, Building materials and products - Hygrothermal properties - Tabulated design values and procedures for determining declared and design thermal values

EN 335:2013, Durability of wood and wood-based products - Use classes: definitions, application to solid wood and wood-based products

EN 350:2016, Durability of wood and woodbased products - Testing and classification of the durability to biological agents of wood and woodbased materials

EN 460:1994, Durability of wood and wood-based products - Natural durability of solid wood - Guide to the durability requirements for wood to be used in hazard classes

### research reports

Stabförmige Bauteile aus Brettsperrholz by H.J. Blaß and M. Flaig, Karlsruher Berichte zum Ingenieurholzbau Band 24, Germany, dated 2012

Biegeträger aus Brettsperrholz bei Beanspruchung in Plattenebene by M. Flaig, Dissertation, Karlsruher Berichte zum Ingenieurholzbau Band 26, Germany, dated 2013

Derix X-LAM

References

Annex 7