

Approval body for construction products  
and types of construction

Bautechnisches Prüfamt

An institution established by the Federal and  
Laender Governments



## European Technical Assessment

**ETA-17/0979**  
**of 22 July 2019**

English translation prepared by DIBt - Original version in German language

### General Part

Technical Assessment Body issuing the  
European Technical Assessment:

Deutsches Institut für Bautechnik

Trade name of the construction product

fischer injection system FIS EM Plus

Product family  
to which the construction product belongs

Bonded fastener for use in concrete

Manufacturer

fischerwerke GmbH & Co. KG  
Otto-Hahn-Straße 15  
79211 Denzlingen  
DEUTSCHLAND

Manufacturing plant

fischerwerke

This European Technical Assessment  
contains

41 pages including 3 annexes which form an integral part  
of this assessment

This European Technical Assessment is  
issued in accordance with Regulation (EU)  
No 305/2011, on the basis of

EAD 330499-01-0601

This version replaces

ETA-17/0979 issued on 6 December 2018

The European Technical Assessment is issued by the Technical Assessment Body in its official language. Translations of this European Technical Assessment in other languages shall fully correspond to the original issued document and shall be identified as such.

Communication of this European Technical Assessment, including transmission by electronic means, shall be in full. However, partial reproduction may only be made with the written consent of the issuing Technical Assessment Body. Any partial reproduction shall be identified as such.

This European Technical Assessment may be withdrawn by the issuing Technical Assessment Body, in particular pursuant to information by the Commission in accordance with Article 25(3) of Regulation (EU) No 305/2011.

## Specific Part

### 1 Technical description of the product

The "fischer injection system FIS EM Plus" is a bonded fastener consisting of a cartridge with injection mortar fischer FIS EM Plus and a steel element according to Annex A5.

The steel element is placed into a drilled hole filled with injection mortar and is anchored via the bond between metal part, injection mortar and concrete.

The product description is given in Annex A.

### 2 Specification of the intended use in accordance with the applicable European Assessment Document

The performances given in Section 3 are only valid if the anchor is used in compliance with the specifications and conditions given in Annex B.

The verifications and assessment methods on which this European Technical Assessment is based lead to the assumption of a working life of the anchor of at least 50 or 100 years. The indications given on the working life cannot be interpreted as a guarantee given by the producer, but are to be regarded only as a means for choosing the right products in relation to the expected economically reasonable working life of the works.

### 3 Performance of the product and references to the methods used for its assessment

#### 3.1 Mechanical resistance and stability (BWR 1)

Essential characteristic	Performance
Characteristic resistance for static and quasi-static tension load	See Annex C 1 to C 12
Characteristic resistance for static and quasi-static shear load	See Annex C 1 to C 4
Displacements for static and quasi-static loads	See Annex C 13 to C 14
Characteristic resistance for seismic performance categories C1 and C2	See Annex C 15 to C 18
Durability	See Annex B 2

#### 3.2 Hygiene, health and the environment (BWR 3)

Essential characteristic	Performance
Content, emission and/or release of dangerous substances	No performance assessed

### 4 Assessment and verification of constancy of performance (AVCP) system applied, with reference to its legal base

In accordance with EAD 330499-01-0601 according to Article 66 Paragraph 3 of Regulation (EU) No 305/2011 the applicable European legal act is: [96/582/EC].

The system to be applied is: 1

**5 Technical details necessary for the implementation of the AVCP system, as provided for in the applicable European Assessment Document**

Technical details necessary for the implementation of the AVCP system are laid down in the control plan deposited at Deutsches Institut für Bautechnik.

Issued in Berlin on 22 July 2019 by Deutsches Institut für Bautechnik

Dr.-Ing. Lars Eckfeldt  
p. p. Head of Department

*beglaubigt:*  
Lange

### Installation conditions part 1

#### fischer anchor rod

##### Pre-positioned installation

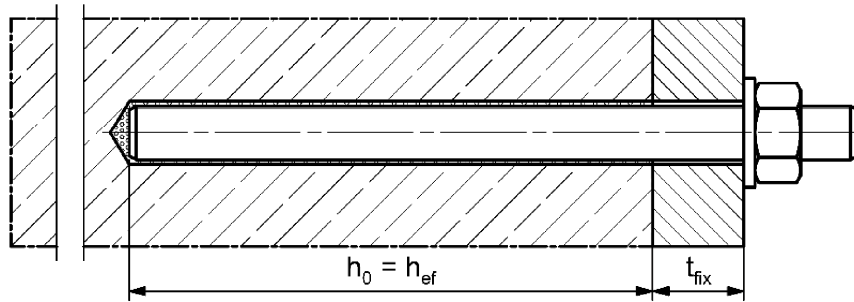

##### Push through installation (annular gap filled with mortar)

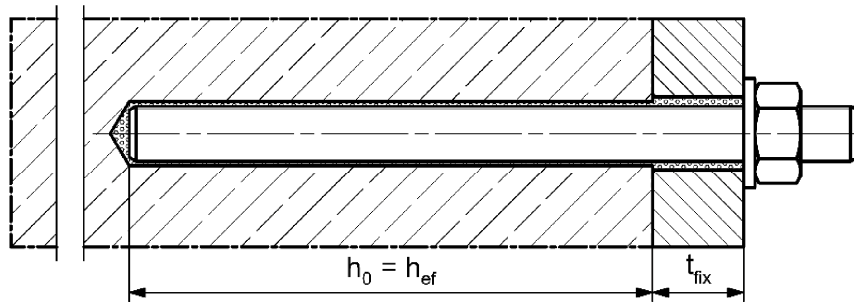

##### Pre-positioned or push through installation with subsequently injected filling disk (annular gap filled with mortar)

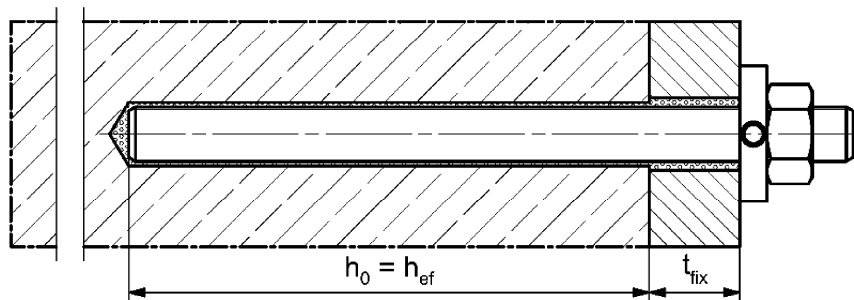

Figures not to scale

$h_0$  = drill hole depth

$h_{ef}$  = effective embedment depth

$t_{fix}$  = thickness of fixture

fischer injection system FIS EM Plus

**Product description**  
Installation conditions part 1

**Annex A 1**

## Installation conditions part 2

### fischer internal threaded anchor RG MI

#### Pre-positioned installation

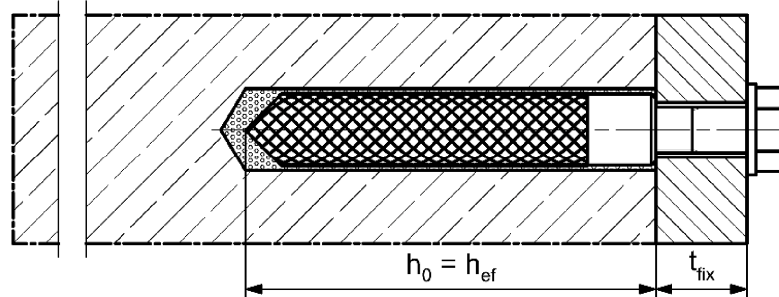

#### Pre-positioned installation with subsequently injected filling disk (annular gap filled with mortar)

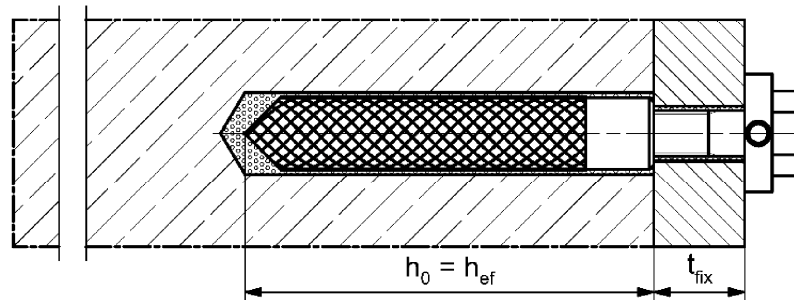

Figures not to scale

$h_0$  = drill hole depth

$h_{ef}$  = effective embedment depth

$t_{fix}$  = thickness of fixture

fischer injection system FIS EM Plus

**Product description**  
Installation conditions part 2

**Annex A 2**

### Installation conditions part 3

#### Reinforcing bar

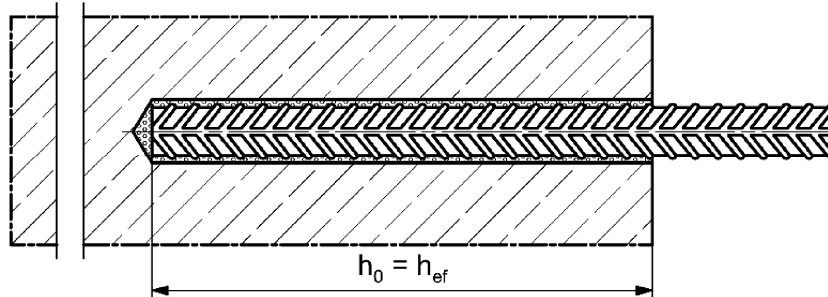

#### fischer rebar anchor FRA

##### Pre-positioned installation

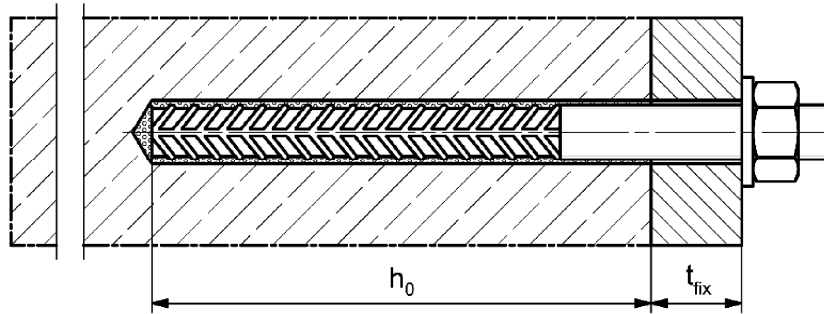

##### Push through installation (annular gap filled with mortar)

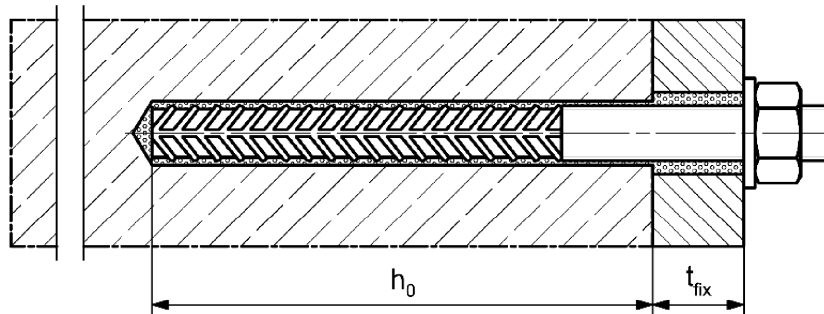

Figures not to scale

$h_0$  = drill hole depth

$h_{ef}$  = effective embedment depth

$t_{fix}$  = thickness of fixture

fischer injection system FIS EM Plus

**Product description**  
Installation conditions part 3

**Annex A 3**

### Overview system components part 1

**Injection cartridge (shuttle cartridge) with sealing cap; Size: 390 ml, 585 ml, 1100 ml, 1500 ml**

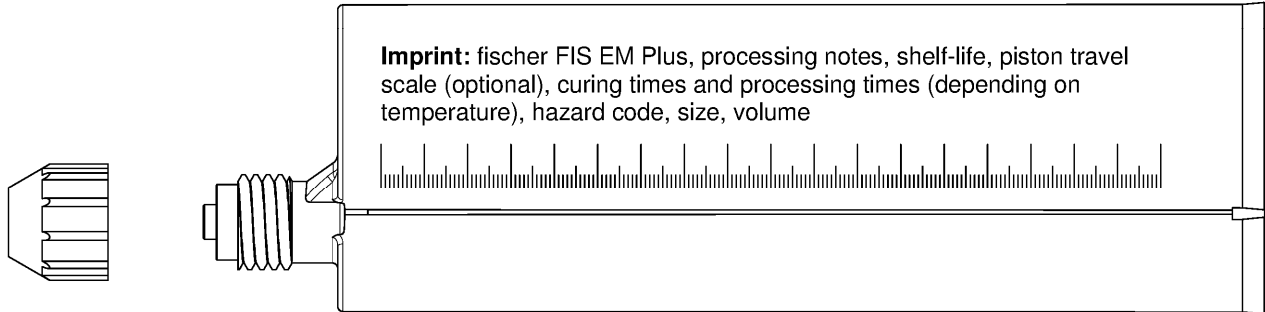

**Static mixer FIS MR Plus or UMR**

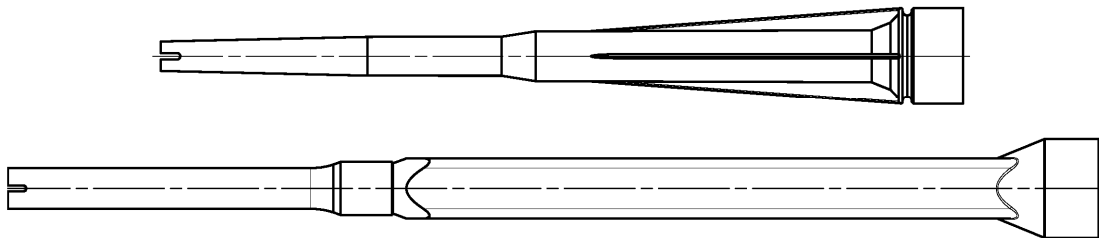

**Injection adapter and Extension tube for static mixer**

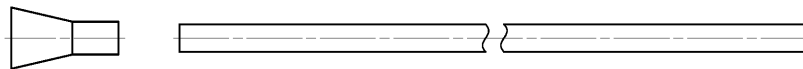

**Cleaning brush BS / BSB**



**Blow-out pump ABP**



Figures not to scale

fischer injection system FIS EM Plus

**System description**

Overview system components part 1;  
cartridges / static mixer / accessories

**Annex A 4**



**Overview system components part 2**

**fischer anchor rod**

Size: M8, M10, M12, M14, M16, M20, M22, M24, M27, M30

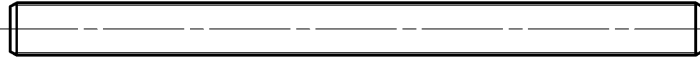

**fischer internal threaded anchor RG MI**

Size: M8, M10, M12, M16, M20



**Screw / threaded rod / washer / hexagon nut**

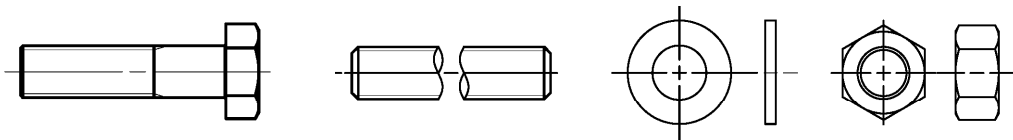

**fischer filling disk FFD with injection adapter**

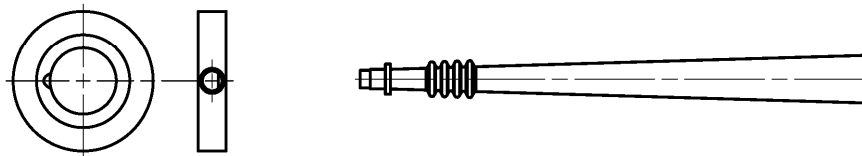

**Reinforcing bar**

Nominal diameter:  $\phi 8$ ,  $\phi 10$ ,  $\phi 12$ ,  $\phi 14$ ,  $\phi 16$ ,  $\phi 18$ ,  $\phi 20$ ,  $\phi 22$ ,  $\phi 24$ ,  $\phi 25$ ,  $\phi 26$ ,  $\phi 28$ ,  $\phi 30$ ,  $\phi 32$ ,  $\phi 34$ ,  $\phi 36$ ,  $\phi 40$



**fischer rebar anchor FRA**

Size: M12, M16, M20, M24



Figures not to scale

fischer injection system FIS EM Plus

**System description**







Overview system components part 2;  
steel components

**Annex A 5**

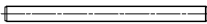
Table A6.1: Materials				
Part	Designation	Material		
1	Injection cartridge	Mortar, hardener, filler		
	Steel grade	Steel, zinc plated	Stainless steel A4 <sup>1)</sup>	High corrosion resistant steel C <sup>2)</sup>
2	Anchor rod	Property class 5.8 or 8.8; EN ISO 898-1:2013 zinc plated $\geq 5 \mu\text{m}$ , EN ISO 4042:1999 A2K or hot-dip galvanized $\geq 40 \mu\text{m}$ EN ISO 10684:2004 $f_{uk} \leq 1000 \text{ N/mm}^2$ $A_5 > 12\%$ fracture elongation	Property class 50, 70 or 80 EN ISO 3506-1:2009 1.4401; 1.4404; 1.4578; 1.4571; 1.4439; 1.4362; 1.4062, 1.4662, 1.4462; EN 10088-1:2014 <sup>1)</sup> $f_{uk} \leq 1000 \text{ N/mm}^2$ $A_5 > 12\%$ fracture elongation	Property class 50 or 80 EN ISO 3506-1:2009 or property class 70 with $f_{yk} = 560 \text{ N/mm}^2$ 1.4565; 1.4529; EN 10088-1:2014 $f_{uk} \leq 1000 \text{ N/mm}^2$ $A_5 > 12\%$ fracture elongation
Fracture elongation $A_5 > 8 \%$ , for applications without requirements for seismic performance category C2				
3	Washer ISO 7089:2000	zinc plated $\geq 5 \mu\text{m}$ , EN ISO 4042:1999 A2K or hot-dip galvanized $\geq 40 \mu\text{m}$ EN ISO 10684:2004	1.4401; 1.4404; 1.4578; 1.4571; 1.4439; 1.4362; EN 10088-1:2014	1.4565; 1.4529; EN 10088-1:2014
4	Hexagon nut	Property class 5 or 8; EN ISO 898-2:2012 zinc plated $\geq 5 \mu\text{m}$ , ISO 4042:1999 A2K or hot-dip galvanized $\geq 40 \mu\text{m}$ EN ISO 10684:2004	Property class 50, 70 or 80 EN ISO 3506-1:2009 1.4401; 1.4404; 1.4578; 1.4571; 1.4439; 1.4362; EN 10088-1:2014	Property class 50, 70 or 80 EN ISO 3506-1:2009 1.4565; 1.4529 EN 10088-1:2014
5	fischer internal threaded anchor RG MI	Property class 5.8 ISO 898-1:2013 zinc plated $\geq 5 \mu\text{m}$ , ISO 4042:1999 A2K	Property class 70 EN ISO 3506-1:2009 1.4401; 1.4404; 1.4578; 1.4571; 1.4439; 1.4362; EN 10088-1:2014	Property class 70 EN ISO 3506-1:2009 1.4565; 1.4529; EN 10088-1:2014
6	Commercial standard screw or anchor / threaded rod for fischer internal threaded anchor RG MI	Property class 5.8 or 8.8; EN ISO 898-1:2013 zinc plated $\geq 5 \mu\text{m}$ , ISO 4042:1999 A2K $A_5 > 8 \%$ fracture elongation	Property class 70 EN ISO 3506-1:2009 1.4401; 1.4404; 1.4578; 1.4571; 1.4439; 1.4362; EN 10088-1:2014 <sup>1)</sup> $A_5 > 8 \%$ fracture elongation	Property class 70 EN ISO 3506-1:2009 1.4565; 1.4529; EN 10088-1:2014 $A_5 > 8 \%$ fracture elongation
7	fischer filling disk FFD similar to DIN 6319-G	zinc plated $\geq 5 \mu\text{m}$ , EN ISO 4042:1999 A2K or hot-dip galvanized $\geq 40 \mu\text{m}$ EN ISO 10684:2004	1.4401; 1.4404; 1.4578; 1.4571; 1.4439; 1.4362; EN 10088-1:2014	1.4565; 1.4529; EN 10088-1:2014
8	Reinforcing bar EN 1992-1-1:2004 and AC:2010, Annex C	Bars and de-coiled rods, class B or C with $f_{yk}$ and k according to NDP or NCL of EN 1992-1-1:2004+AC:2010 $f_{uk} = f_{tk} = k \cdot f_{yk}$		
9	fischer rebar anchor FRA	Rebar part: Bars and de-coiled rods class B or C with $f_{yk}$ and k according to NDP or NCL of EN 1992-1-1:2004+AC:2010 $f_{uk} = f_{tk} = k \cdot f_{yk}$	Threaded part: Property class 70 or 80 EN ISO 3506-1:2009 1.4401, 1.4404, 1.4571, 1.4578, 1.4439, 1.4362, 1.4062 EN 10088-1:2014 <sup>1)</sup> 1.4565; 1.4529 EN 10088-1:2014 <sup>2)</sup>	
<sup>1)</sup> acc. to EN 10088-1:2014 Corrosion resistance class CRC III acc. to EN 1993-1-4:2015 <sup>2)</sup> acc. to EN 10088-1:2014 Corrosion resistance class CRC V acc. to EN 1993-1-4:2015				
fischer injection system FIS EM Plus				<b>Annex A 6</b>
<b>Product description</b> Materials				

## Specifications of intended use (part 1)

**Table B1.1:** Overview use and performance categories

Anchorages subject to		FIS EM Plus with ...							
		Anchor rod 	fischer internal threaded anchor RG MI 	Reinforcing bar 	fischer rebar anchor FRA 				
Hammer drilling with standard drill bit 		all sizes							
Hammer drilling with hollow drill bit (fischer "FHD", Heller "Duster Expert"; Bosch „Speed Clean“; Hilti "TE-CD, TE-YD") 		Nominal drill bit diameter ( $d_0$ ) 12 mm to 35 mm							
Diamond drilling 		all sizes							
Static and quasi static load, in	uncracked concrete	all sizes	Tables: C1.1 C4.1 C5.1	all sizes	Tables: C2.1 C4.1 C7.1	all sizes	Tables: C3.1 C4.1 C9.1	all sizes	Tables: C3.2 C4.1 C11.1
	cracked concrete		C6.1 C13.1		C8.1 C13.2		C10.1 C14.1		C12.1 C14.2
Seismic performance category (only hammer drilling with standard / hollow drill bits)	C1	M10 to M30	Tables: C15.1 C16.2 C17.1	-	-	-	Tables: C16.1 C16.2 C17.2	-	-
	C2	M12 M16 M20 M24	Tables: C15.1 C16.2 C18.1				-		
Use category	I1 dry or wet concrete	all sizes							
	I2 water filled hole	all sizes (not permitted in combined with service life time 100 years)							
Installation direction	D3 (downward and horizontal and upwards (e.g. overhead) installation)								
Installation temperature	$T_{i,min} = -5\text{ °C}$ to $T_{i,max} = +40\text{ °C}$								
In-service temperature	Temperature range I	-40 °C to +60 °C		(max. short term temperature +60 °C ; max. long term temperature +35 °C)					
	Temperature range II	-40 °C to +72 °C		(max. short term temperature +72 °C ; max. long term temperature +50 °C)					
fischer injection system FIS EM Plus									<b>Annex B 1</b>
Intended use Specifications (part 1)									

## Specifications of intended use (part 2)

### Base materials:

- Compacted reinforced or unreinforced normal weight concrete without fibres of strength classes C20/25 to C50/60 according to EN 206:2013+A1:2016

### Use conditions (Environmental conditions):

- Structures subject to dry internal conditions (zinc coated steel, stainless steel or high corrosion resistant steel).
- For all other conditions according to EN1993-1-4:2015 corresponding to corrosion resistance classes to Annex A 6 table 6.1.

### Design:

- Anchorages have to be designed by a responsible engineer with experience of concrete anchor design.
- Verifiable calculation notes and drawings are to be prepared taking account of the loads to be anchored. The position of the anchor is indicated on the design drawings (e. g. position of the anchor relative to reinforcement or to supports, etc.).
- Anchorages are designed in accordance with:  
EN 1992-4:2018 and EOTA Technical Report TR 055.  
Anchorages shall be positioned outside of critical regions (e.g. plastic hinges) of the concrete structure. Fastening in stand-off installation or with a grout layer under seismic action are not covered in this European Technical Assessment (ETA).

### Installation:

- Anchor installation is to be carried out by appropriately qualified personnel and under the supervision of the person responsible for technical matters of the site
- In case of aborted hole: The hole shall be filled with mortar
- Anchorage depth should be marked and adhered to on installation
- Overhead installation is allowed

fischer injection system FIS EM Plus

**Intended use**  
Specifications (part 2)

**Annex B 2**

**Table B3.1:** Installation parameters for anchor rods

Anchor rods		Thread	M8	M10	M12	M14	M16	M20	M22	M24	M27	M30
Width across flats	SW	[mm]	13	17	19	22	24	30	32	36	41	46
Nominal drill hole diameter	$d_0$		10	12	14	16	18	22 24 <sup>1)</sup>	25	28	30	35
Drill hole depth	$h_0$		$h_0 = h_{ef}$									
Effective embedment depth	$h_{ef, min}$		60	60	70	75	80	90	93	96	108	120
	$h_{ef, max}$		160	200	240	280	320	400	440	480	540	600
Diameter of the clearance hole of the fixture	pre-positioned installation $d_f$		9	12	14	16	18	22	24	26	30	33
	push through installation $d_f$		12	14	16	18	20	26	28	30	33	40
Minimum thickness of concrete member	$h_{min}$	$h_{ef} + 30$ ( $\geq 100$ )			$h_{ef} + 2d_0$							
Maximum torque moment for attachment of the fixture	$\max T_{fix}$	[Nm]	10	20	40	50	60	120	135	150	200	300

<sup>1)</sup> Both drill hole diameters can be used

**fischer anchor rod**

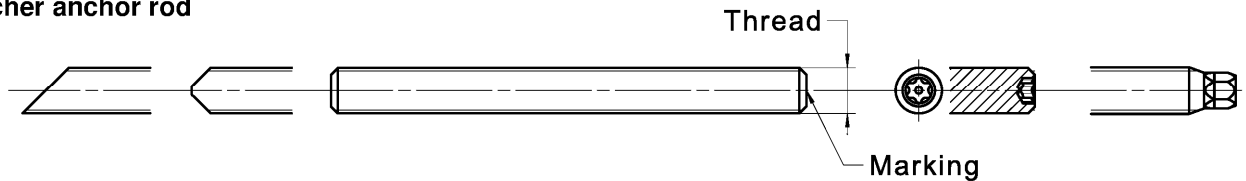

**Marking (on random place) fischer anchor rod:**

- Property class 8.8, stainless steel, property class 80 and high corrosion resistant steel, property class 80: •
- Stainless steel A4, property class 50 and high corrosion resistant steel, property class 50: ••
- Alternatively: Colour coding according to DIN 976-1

**Installation conditions:**

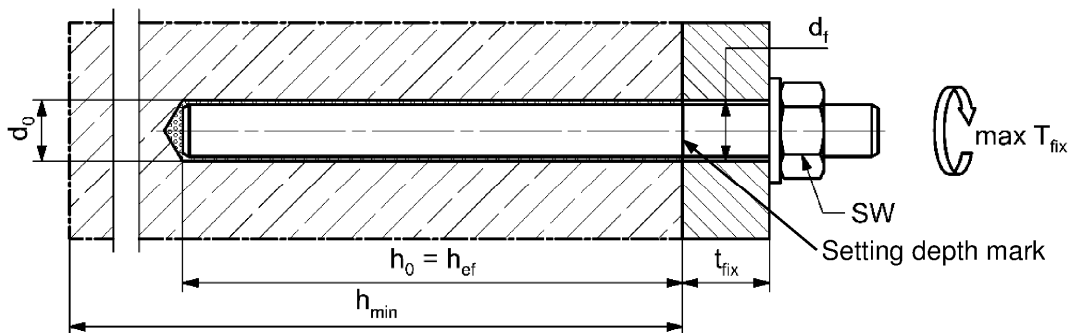

**Commercial standard threaded rods, washers and hexagon nuts may also be used if the following requirements are fulfilled**

- Materials, dimensions and mechanical properties according to Annex A 6, Table A6.1
- Inspection certificate 3.1 according to EN 10204:2004, the documents have to be stored
- Setting depth is marked

Figures not to scale

fischer injection system FIS EM Plus

**Intended use**  
Installation parameters anchor rods

**Annex B 3**

<b>Table B4.1:</b> Minimum spacing and minimum edge distance for anchor rods and reinforcing bars											
<b>Anchor rods</b>			<b>M8</b>	<b>M10</b>	<b>M12</b>	<b>M14</b>	<b>M16</b>	<b>-</b>	<b>M20</b>	<b>M22</b>	<b>M24</b>
<b>Reinforcing bars (nominal diameter)</b>		$\phi$	<b>8</b>	<b>10</b>	<b>12</b>	<b>14</b>	<b>16</b>	<b>18</b>	<b>20</b>	<b>22</b>	<b>24</b>
<b>Minimum edge distance</b>											
Uncracked / cracked concrete	$c_{min}$	[mm]	40	45	45	45	50	55	55	55	60
Minimum spacing	$s_{min}$		according to Annex B5								
<b>Minimum spacing</b>											
Uncracked / cracked concrete	$s_{min}$	[mm]	40	45	55	60	65	85	85	95	105
Minimum edge distance	$c_{min}$		according to Annex B5								
<b>Required projecting area</b>											
Uncracked concrete	$A_{sp,req}$	[1000	8	13	22	23	24	38,5	38,5	39,5	40
Cracked concrete		mm <sup>2</sup> ]	6,5	10	16,5	17,5	18,5	29,5	29,5	30	30,5
<b>Anchor rods</b>											
<b>Reinforcing bars (nominal diameter)</b>		$\phi$	<b>-</b>	<b>-</b>	<b>M27</b>	<b>-</b>	<b>M30</b>	<b>-</b>	<b>-</b>	<b>-</b>	<b>-</b>
<b>Reinforcing bars (nominal diameter)</b>		$\phi$	<b>25</b>	<b>26</b>	<b>-</b>	<b>28</b>	<b>30</b>	<b>32</b>	<b>34</b>	<b>36</b>	<b>40</b>
<b>Minimum edge distance</b>											
Uncracked / cracked concrete	$c_{min}$	[mm]	75	75	75	80	80	120	120	135	175
Minimum spacing	$s_{min}$		according to Annex B5								
<b>Minimum spacing</b>											
Uncracked / cracked concrete	$s_{min}$	[mm]	120	120	120	140	140	160	160	160	160
Minimum edge distance	$c_{min}$		according to Annex B5								
<b>Required projecting area</b>											
Uncracked concrete	$A_{sp,req}$	[1000	47,5	47,5	47,5	64	64	64	64	64	64
Cracked concrete		mm <sup>2</sup> ]	36,5	36,5	36,5	49	49	49	49	49	49
<p><b>Splitting failure</b> for minimum edge distance and spacing in dependence of the effective embedment depth <math>h_{ef}</math>.</p> <p>For the calculation of minimum spacing and minimum edge distance of anchors in combination with different embedment depths and thicknesses of concrete members the following equation shall be fulfilled:</p> $A_{sp,req} < A_{sp,t}$ <p><math>A_{sp,req}</math> = required projecting area  <math>A_{sp,t} = A_{sp,ef}</math> = effective projecting area (according to Annex B5)</p>											
fischer injection system FIS EM Plus									<b>Annex B 4</b>		
<b>Intended use</b> Minimum spacing and edge distance for anchor rods and reinforcing bars											

**Table B5.1:** Effective projecting area  $A_{sp,t}$  with concrete member thickness  $h > h_{ef} + 1,5 \cdot c$  and  $h \geq h_{min}$

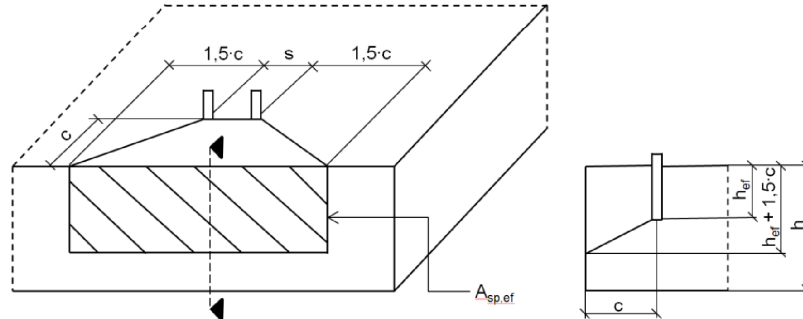

Single anchor	$A_{sp,t} = (3 \cdot c) \cdot (h_{ef} + 1,5 \cdot c)$	$[mm^2]$	with $c \geq c_{min}$
Group of anchors with $s > 3 \cdot c$	$A_{sp,t} = (6 \cdot c) \cdot (h_{ef} + 1,5 \cdot c)$	$[mm^2]$	
Group of anchors with $s \leq 3 \cdot c$	$A_{sp,t} = (3 \cdot c + s) \cdot (h_{ef} + 1,5 \cdot c)$	$[mm^2]$	with $c \geq c_{min}$ and $s \geq s_{min}$

**Table B5.2:** Effektive projecting area  $A_{sp,t}$  with concrete member thickness  $h \leq h_{ef} + 1,5 \cdot c$  and  $h \geq h_{min}$

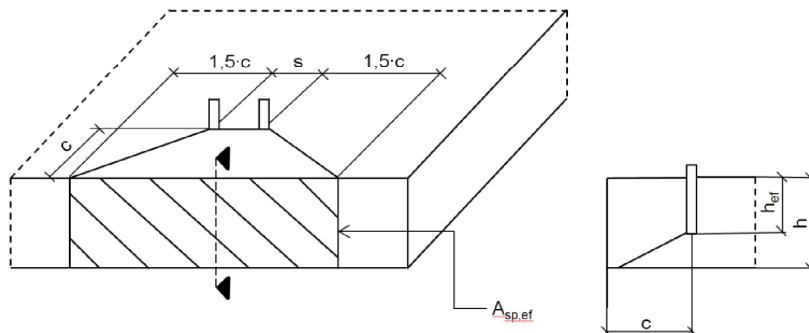

Single anchor	$A_{sp,t} = 3 \cdot c \cdot \text{existing } h$	$[mm^2]$	with $c \geq c_{min}$
Group of anchors with $s > 3 \cdot c$	$A_{sp,t} = 6 \cdot c \cdot \text{existing } h$	$[mm^2]$	
Group of anchors with $s \leq 3 \cdot c$	$A_{sp,t} = (3 \cdot c + s) \cdot \text{existing } h$	$[mm^2]$	with $c \geq c_{min}$ and $s \geq s_{min}$

Edge distance and axial spacing shall be rounded up to at least 5 mm

Figures not to scale

fischer injection system FIS EM Plus

**Intended use**

Minimum thickness of concrete member for anchor rods,  
minimum spacing and edge distance

**Annex B 5**

**Table B6.1:** Installation parameters plus minimum spacing and minimum edge distance for fischer internal threaded anchors RG MI

Internal threaded anchors RG MI		Thread	M8	M10	M12	M16	M20
Diameter of anchor	$d_{nom} = d_H$	[mm]	12	16	18	22	28
Nominal drill hole diameter	$d_0$		14	18	20	24	32
Drill hole depth	$h_0$		$h_0 = h_{ef} = L_H$				
Effective embedment depth ( $h_{ef} = L_H$ )	$h_{ef}$		90	90	125	160	200
Minimum spacing and minimum edge distance	$S_{min} = C_{min}$		55	65	75	95	125
Diameter of clearance hole in the fixture	$d_f$		9	12	14	18	22
Minimum thickness of concrete member	$h_{min}$		120	125	165	205	260
Maximum screw-in depth	$l_{E,max}$		18	23	26	35	45
Minimum screw-in depth	$l_{E,min}$		8	10	12	16	20
Maximum torque moment for attachment of the fixture	$\max T_{fix}$		[Nm]	10	20	40	80

**fischer internal threaded anchor RG MI**

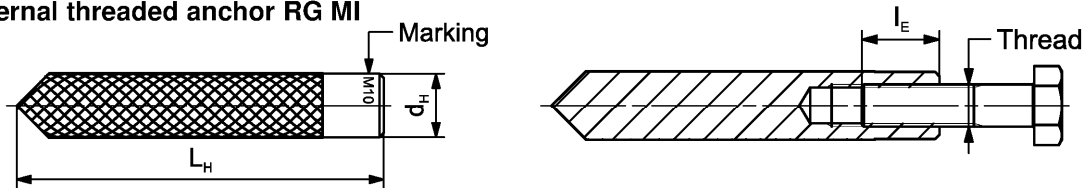

**Marking:** Anchor size e. g.: **M10**  
Stainless steel → additional **A4**; e.g.: **M10 A4**  
High corrosion resistant steel → additional **C**; e.g.: **M10 C**

Retaining bolt or threaded rods (including nut and washer) must comply with the appropriate material and strength class of Annex A 6, Table A6.1

**Installation conditions:**

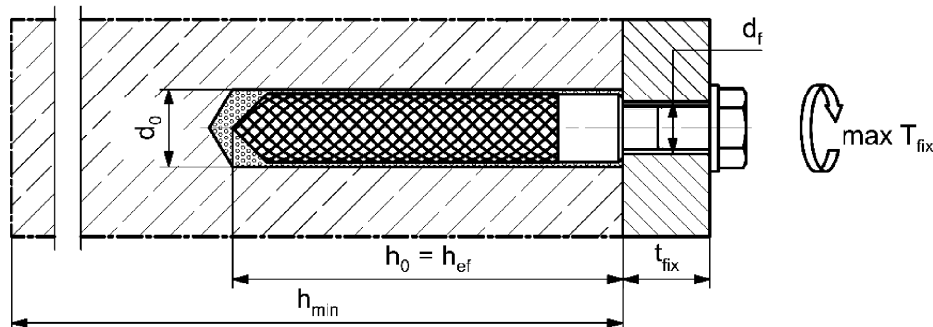

Figures not to scale

fischer injection system FIS EM Plus

**Intended use**  
Installation parameters internal threaded anchors RG MI

**Annex B 6**



**Table B7.1:** Installation parameters for reinforcing bars

Nominal diameter of the bar		$\phi$	8 <sup>1)</sup>	10 <sup>1)</sup>	12 <sup>1)</sup>	14	16	18	20	22	24	
Nominal drill hole diameter	$d_0$	[mm]	10	12	14	16	18	20	25	25	30	30
Drill hole depth	$h_0$		$h_0 = h_{ef}$									
Effective embedment depth	$h_{ef,min}$		60	60	70	75	80	85	90	94	98	
	$h_{ef,max}$		160	200	240	280	320	360	400	440	480	
Minimum thickness of concrete member	$h_{min}$	$h_{ef} + 30$ ( $\geq 100$ )				$h_{ef} + 2d_0$						

Nominal diameter of the bar		$\phi$	25	26	28	30	32	34	36	40	-	
Nominal drill hole diameter	$d_0$	[mm]	30	35	35	40	40	40	45	55	-	
Drill hole depth	$h_0$		$h_0 = h_{ef}$									
Effective embedment depth	$h_{ef,min}$		100	104	112	120	128	136	144	160	-	
	$h_{ef,max}$		500	520	560	600	640	680	720	800	-	
Minimum thickness of concrete member	$h_{min}$	$h_{ef} + 2d_0$										

1) Both drill hole diameters can be used

**Reinforcing bar**



- The minimum value of related rib area  $f_{R,min}$  must fulfil the requirements of EN 1992-1-1:2004+AC:2010
- The rib height must be within the range:  $0,05 \cdot \phi \leq h_{rib} \leq 0,07 \cdot \phi$   
( $\phi$  = Nominal diameter of the bar ,  $h_{rib}$  = rib height)

**Installation conditions:**

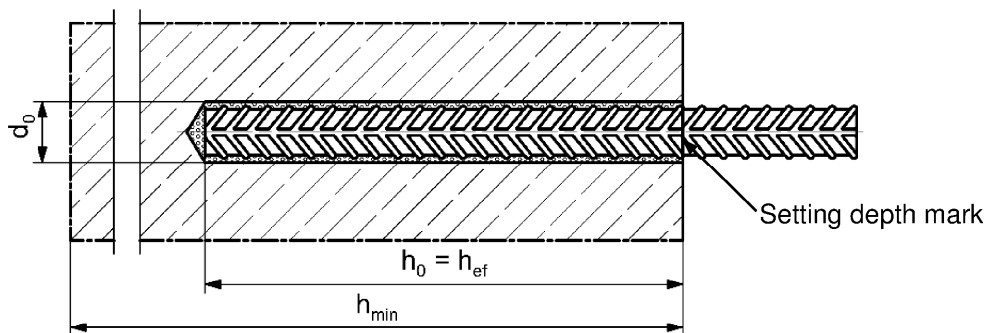

Figures not to scale

fischer injection system FIS EM Plus

**Intended use**  
Installation parameters reinforcing bars

**Annex B 7**

**Table B8.1:** Installation parameters plus minimum spacing and minimum edge distance for fischer rebar anchor FRA

Rebar anchor FRA		Thread	M12 <sup>1)</sup>	M16	M20	M24
Nominal diameter of the bar	$\phi$	[mm]	12	16	20	25
Width across flats	SW		19	24	30	36
Nominal drill hole diameter	$d_0$		14	16	20	30
Drill hole depth	$h_0$		$h_{ef} + l_e$			
Effective embedment depth	$h_{ef,min}$		70	80	90	96
	$h_{ef,max}$		140	220	300	380
Distance concrete surface to welded joint	$l_e$		100			
Minimum spacing and minimum edge distance	$s_{min} = c_{min}$		55	65	85	105
Diameter of clearance hole in the fixture	pre-positioned anchorage $\leq d_f$		14	18	22	26
	push through anchorage $\leq d_f$		18	22	26	32
Minimum thickness of concrete member	$h_{min}$	$h_0 + 30$ ( $\geq 100$ )	$h_0 + 2d_0$			
Maximum torque moment for attachment of the fixture	$\max T_{fix}$	[Nm]	40	60	120	150

<sup>1)</sup> Both drill hole diameters can be used

**fischer rebar anchor FRA**

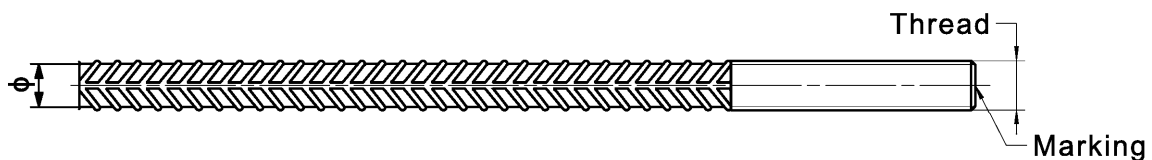

Marking frontal e. g:  FRA (for stainless steel);  
 FRA C (for high corrosion resistant steel)

**Installation conditions:**

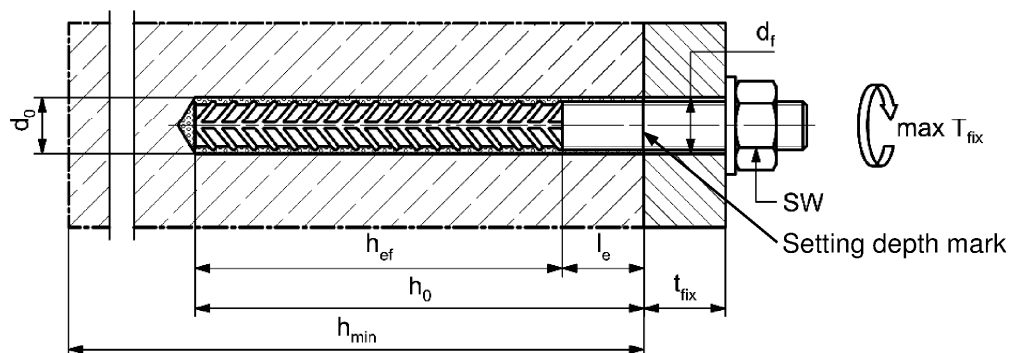

Figures not to scale

fischer injection system FIS EM Plus

**Intended use**  
Installation parameters rebar anchor FRA

**Annex B 8**

**Table B9.1:** Parameters of the cleaning brush BS / BSB (steel brush)

The size of the cleaning brush refers to the drill hole diameter

Nominal drill hole diameter	$d_0$		10	12	14	16	18	20	24	25	28	30	32	35	40	45	55
Steel brush diameter	$d_b$	[mm]	11	14	16	20		25	26	27	30	40			42	47	58

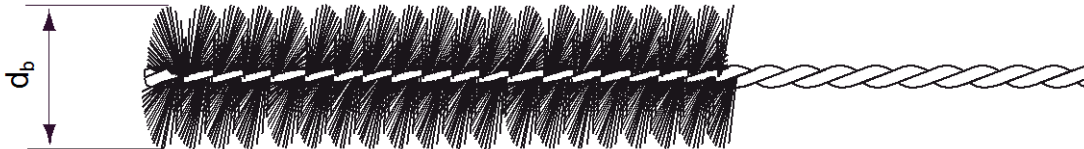

**Table B9.2** Maximum processing time of the mortar and minimum curing time  
(During the curing time of the mortar the concrete temperature may not fall below the listed minimum temperature)

Temperature at anchoring base [°C]	Maximum processing time $t_{work}$	Minimum curing time $t_{cure}$
-5 to -1	240 min	200 h
±0 to +4	150 min	90 h
+5 to +9	120 min	40 h
+10 to +19	30 min	18 h
+20 to +29	14 min	10 h
+30 to +40	7 min	5 h

<sup>1)</sup> In wet concrete or water filled holes the curing times must be doubled





fischer injection system FIS EM Plus

**Intended use**  
Cleaning brush (steel brush)  
Processing time and curing time

**Annex B 9**

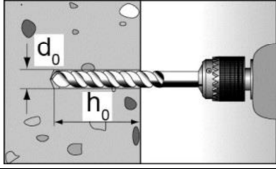
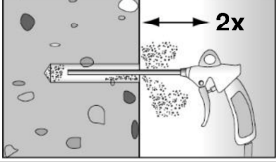
### Installation instructions part 1

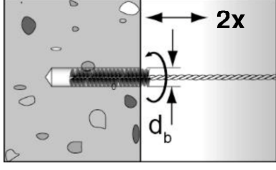
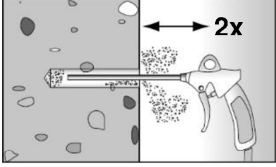
#### Drilling and cleaning the hole (hammer drilling with standard drill bit)

1		<p>Drill the hole. Nominal drill hole diameter <math>d_0</math> and drill hole depth <math>h_0</math> see <b>tables B3.1, B6.1, B7.1, B8.1</b></p>
2		<p>Cleaning the drill hole: Blow out the drill hole twice, with oil free compressed air (<math>p \geq 6</math> bar)</p> 
3		<p>Brush the drill hole twice. For drill hole diameter <math>\geq 30</math> mm use a power drill. For deep holes use an extension. Corresponding brushes see <b>table B9.1</b></p>
4		<p>Cleaning the drill hole: Blow out the drill hole twice, with oil free compressed air (<math>p \geq 6</math> bar)</p> 

Go to step 6

#### Drilling and cleaning the hole (hammer drilling with hollow drill bit)

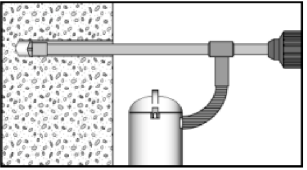
1		<p>Check a suitable hollow drill (see <b>table B1.1</b>) for correct operation of the dust extraction</p>
2		<p>Use a suitable dust extraction system, e. g. Bosch GAS 35 M AFC or a comparable dust extraction system with equivalent performance data</p> <p>Drill the hole with hollow drill bit. The dust extraction system has to extract the drill dust nonstop during the drilling process and must be adjusted to maximum power. Nominal drill hole diameter <math>d_0</math> and drill hole depth <math>h_0</math> see <b>tables B3.1, B6.1, B7.1, B8.1</b></p>

Go to step 6

fischer injection system FIS EM Plus

**Intended use**  
Installation instructions part 1



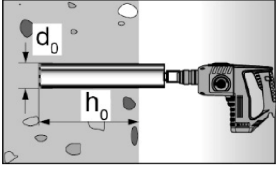
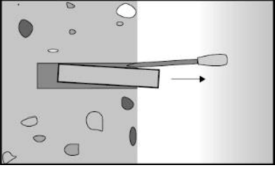
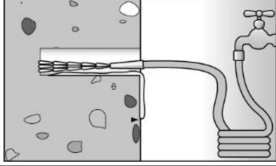
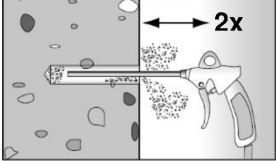
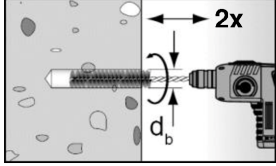
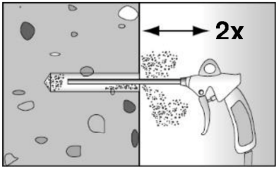

**Annex B 10**

## Installation instructions part 2

### Drilling and cleaning the hole (wet drilling with diamond drill bit)

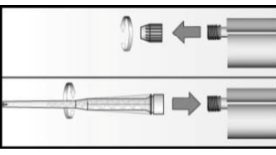
1		<p>Drill the hole. Drill hole diameter <math>d_0</math> and nominal drill hole depth <math>h_0</math> see <b>tables B3.1, B6.1, B7.1, B8.1</b></p>		<p>Break the drill core and remove it</p>
2		<p>Flush the drill hole with clean water until it flows clear</p>		
3		<p>Blow out the drill hole twice, using oil-free compressed air (<math>p &gt; 6</math> bar)</p>		
4		<p>Brush the drill hole twice using a power drill. Corresponding brushes see <b>table B9.1</b></p>		
5		<p>Blow out the drill hole twice, using oil-free compressed air (<math>p &gt; 6</math> bar)</p>		

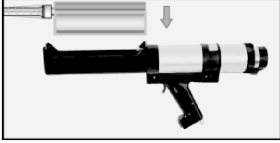
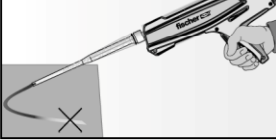
### Preparing the cartridge

6		<p>Remove the sealing cap Screw on the static mixer (the spiral in the static mixer must be clearly visible)</p>		
7			<p>Place the cartridge into the dispenser</p>	
8			<p>Extrude approximately 10 cm of material out until the resin is evenly grey in colour. Do not use mortar that is not uniformly grey</p>	

fischer injection system FIS EM Plus

**Intended use**  
Installation instructions part 2



**Annex B 11**

### Installation instructions part 3

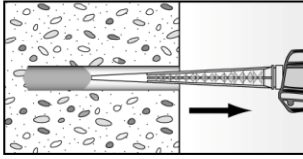
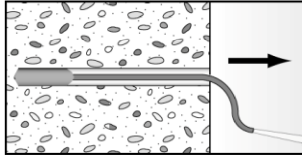
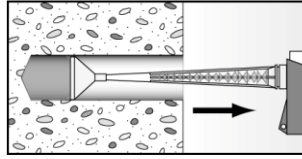
#### Injection of the mortar

<b>9</b>			
	<p>Fill approximately 2/3 of the drill hole with mortar. Always begin from the bottom of the hole and avoid bubbles</p>	<p>For drill hole depth <math>\geq 150</math> mm use an extension tube</p>	<p>For overhead installation, deep holes (<math>h_0 &gt; 250</math> mm) or drill hole diameter (<math>d_0 \geq 40</math> mm) use an injection-adapter</p>

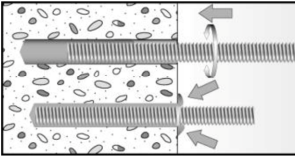
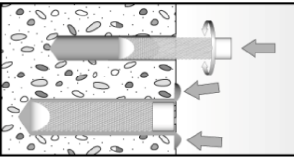
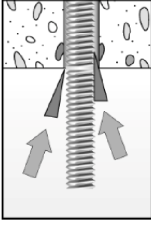
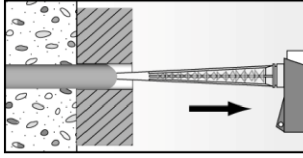
#### Installation of anchor rods or fischer internal threaded anchors RG MI

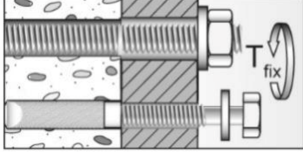
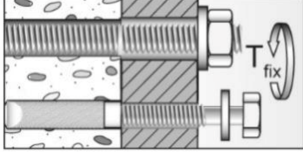
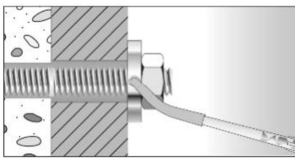
<b>10</b>			<p>Only use clean and oil-free anchor elements. Mark the setting depth of the anchor. Push the anchor rod or fischer internal threaded RG MI anchor down to the bottom of the hole, turning it slightly while doing so. After inserting the anchor element, excess mortar must be emerged around the anchor element.</p>			
		<p>For overhead installations support the anchor rod with wedges (e. g. fischer centering wedges) or fischer overhead clips.</p>		<p>For push through installation fill the annular gap with mortar</p>		
<b>11</b>		<p>Wait for the specified curing time <math>t_{cure}</math> see <b>table B9.2</b></p>	<td style="text-align: center; vertical-align: middle;"><b>12</b></td> <td>  </td> <td> <p>Mounting the fixture max <math>T_{fix}</math> see <b>tables B3.1 and B6.1</b></p> </td>	<b>12</b>		<p>Mounting the fixture max <math>T_{fix}</math> see <b>tables B3.1 and B6.1</b></p>
<b>Option</b>		<p>After the minimum curing time is reached, the gap between anchor and fixture (annular clearance) may be filled with mortar via the fischer filling disc FFD. Compressive strength <math>\geq 50</math> N/mm<sup>2</sup> (e.g. fischer injection mortars FIS HB, FIS SB, FIS V, FIS EM Plus) ATTENTION: Using fischer filling disk FFD reduces <math>t_{fix}</math> (usable length of the anchor)</p>				



fischer injection system FIS EM Plus

**Intended use**  
Installation instructions part 3

**Annex B 12**

### Installation instructions part 4

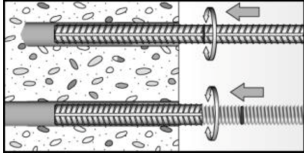
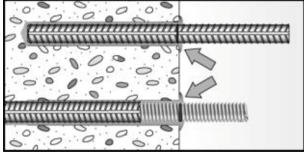
#### Installation reinforcing bars and fischer rebar anchor FRA

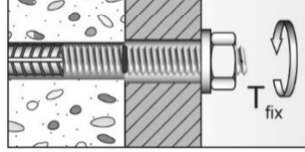
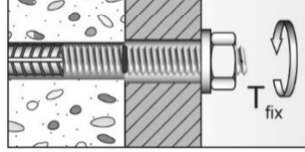
10		<p>Only use clean and oil-free reinforcing bars or fischer FRA. Mark the setting depth. Turn while using force to push the reinforcement bar or the fischer FRA into the filled hole up to the setting depth mark</p>			
10		<p>When the setting depth mark is reached, excess mortar must be emerged from the mouth of the drill hole.</p>			
11	 <p>Wait for the specified curing time <math>t_{cure}</math> see <b>table B9.2</b></p>	<td data-bbox="815 703 911 875">12</td> <td data-bbox="911 703 1230 875">  </td> <td data-bbox="1230 703 1530 875"> <p>Mounting the fixture max <math>T_{fix}</math> see <b>table B8.1</b></p> </td>	12		<p>Mounting the fixture max <math>T_{fix}</math> see <b>table B8.1</b></p>

fischer injection system FIS EM Plus

**Intended use**  
Installation instructions part 4

**Annex B 13**



<b>Table C1.1:</b> Essential characteristics <sup>3)</sup> for the <b>steel bearing capacity</b> under tensile / shear load of <b>fischer anchor rods</b> and <b>standard threaded rods</b>													
Anchor rod / standard threaded rod			M8	M10	M12	M14	M16	M20	M22	M24	M27	M30	
<b>Bearing capacity under tensile load, steel failure</b>													
Characteristic resistance $N_{Rk,s}$	Steel zinc plated	Property class	5.8	19(17)	29(27)	43	58	79	123	152	177	230	281
			8.8	29(27)	47(43)	68	92	126	196	243	282	368	449
	Stainless steel A4 and high corrosion resistant steel C		50	19	29	43	58	79	123	152	177	230	281
			70	26	41	59	81	110	172	212	247	322	393
			80	30	47	68	92	126	196	243	282	368	449
<b>Partial factors <sup>1)</sup></b>													
Partial factor $\gamma_{Ms,N}$	Steel zinc plated	Property class	5.8	1,50									
			8.8	1,50									
	Stainless steel A4 and high corrosion resistant steel C		50	2,86									
			70	1,50 <sup>2)</sup> / 1,87									
			80	1,60									
<b>Bearing capacity under shear load, steel failure</b>													
<b>without lever arm</b>													
Characteristic resistance $V^0_{Rk,s}$	Steel zinc plated	Property class	5.8	9(8)	15(13)	21	29	39	61	76	89	115	141
			8.8	15(13)	23(21)	34	46	63	98	122	141	184	225
	Stainless steel A4 and high corrosion resistant steel C		50	9	15	21	29	39	61	76	89	115	141
			70	13	20	30	40	55	86	107	124	161	197
			80	15	23	34	46	63	98	122	141	184	225
Ductility factor		$k_7$	[-] 1,0										
<b>with lever arm</b>													
Charact. resistance $M^0_{Rk,s}$	Steel zinc plated	Property class	5.8	19(16)	37(33)	65	104	166	324	447	560	833	1123
			8.8	30(26)	60(53)	105	167	266	519	716	896	1333	1797
	Stainless steel A4 and high corrosion resistant steel C		50	19	37	65	104	166	324	447	560	833	1123
			70	26	52	92	146	232	454	626	784	1167	1573
			80	30	60	105	167	266	519	716	896	1333	1797
<b>Partial factors <sup>1)</sup></b>													
Partial factor $\gamma_{Ms,V}$	Steel zinc plated	Property class	5.8	1,25									
			8.8	1,25									
	Stainless steel A4 and high corrosion resistant steel C		50	2,38									
			70	1,25 <sup>2)</sup> / 1,56									
			80	1,33									
<sup>1)</sup> In absence of other national regulations <sup>2)</sup> Only admissible for high corrosion resistant steel C, with $f_{yk} / f_{uk} \geq 0,8$ and $A_s > 12 \%$ (e.g. fischer anchor rods) <sup>3)</sup> Values in brackets are valid for undersized threaded rods with smaller stress area $A_s$ for hotdip galvanized standard threaded rods according to EN ISO 10684:2004+AC:2009													
fischer injection system FIS EM Plus											<b>Annex C 1</b>		
<b>Performance</b> Essential characteristics for the steel bearing capacity of fischer anchor rods and standard threaded rods													



<b>Table C2.1:</b> Essential characteristics for the <b>steel bearing capacity</b> under tensile / shear load of <b>fischer internal threaded anchors RG MI</b>								
<b>fischer internal threaded anchors RG MI</b>			<b>M8</b>	<b>M10</b>	<b>M12</b>	<b>M16</b>	<b>M20</b>	
<b>Bearing capacity under tensile load, steel failure</b>								
Charact. resistance with screw	Property class	5.8	[kN]	19	29	43	79	123
		8.8		29	47	68	108	179
		A4		26	41	59	110	172
		class 70		26	41	59	110	172
<b>Partial factors<sup>1)</sup></b>								
Partial factors	$\gamma_{Ms,N}$	5.8	[-]	1,50				
		8.8		1,50				
		A4		1,87				
		class 70		1,87				
<b>Bearing capacity under shear load, steel failure</b>								
<b>Without lever arm</b>								
Charact. resistance with screw	Property class	5.8	[kN]	9,2	14,5	21,1	39,2	62,0
		8.8		14,6	23,2	33,7	54,0	90,0
		A4		12,8	20,3	29,5	54,8	86,0
		class 70		12,8	20,3	29,5	54,8	86,0
Ductility factor		k <sub>7</sub>	[-]	1,0				
<b>With lever arm</b>								
Charact. resistance with screw	Property class	5.8	[Nm]	20	39	68	173	337
		8.8		30	60	105	266	519
		A4		26	52	92	232	454
		class 70		26	52	92	232	454
<b>Partial factors<sup>1)</sup></b>								
Partial factors	$\gamma_{Ms,V}$	5.8	[-]	1,25				
		8.8		1,25				
		A4		1,56				
		class 70		1,56				
<sup>1)</sup> In absence of other national regulations								
fischer injection system FIS EM Plus							<b>Annex C 2</b>	
<b>Performance</b> Essential characteristics for the steel bearing capacity of fischer internal threaded anchor RG MI								

<b>Table C3.1:</b> Essential characteristics for the <b>steel bearing capacity</b> under tensile / shear load of <b>reinforcing bars</b>																		
Nominal diameter of the bar	$\phi$	8	10	12	14	16	18	20	22	24	25	26	28	30	32	34	36	40
<b>Bearing capacity under tensile load, steel failure</b>																		
Characteristic resistance	$N_{Rk,s}$	[kN]	$A_s \cdot f_{uk}^{(1)}$															
<b>Bearing capacity under shear load, steel failure</b>																		
<b>Without lever arm</b>																		
Characteristic resistance	$V^0_{Rk,s}$	[kN]	$0,5 \cdot A_s \cdot f_{uk}^{(1)}$															
Ductility factor	$k_7$	[-]	0,8															
<b>With lever arm</b>																		
Characteristic resistance	$M^0_{Rk,s}$	[Nm]	$1,2 \cdot W_{el} \cdot f_{uk}^{(1)}$															
<sup>1)</sup> $f_{uk}$ or $f_{yk}$ respectively must be taken from the specifications of the reinforcing bar																		
<b>Table C3.2:</b> Essential characteristics for the <b>steel bearing capacity</b> under tensile / shear load of <b>fischer rebar anchors FRA</b>																		
<b>fischer rebar anchor FRA</b>			<b>M12</b>			<b>M16</b>			<b>M20</b>			<b>M24</b>						
<b>Bearing capacity under tensile load, steel failure</b>																		
Characteristic resistance	$N_{Rk,s}$	[kN]	63			111			173			270						
<b>Partial factor<sup>1)</sup></b>																		
Partial factor	$\gamma_{Ms,N}$	[-]	1,4															
<b>Bearing capacity under shear load, steel failure</b>																		
<b>Without lever arm</b>																		
Characteristic resistance	$V^0_{Rk,s}$	[kN]	30			55			86			124						
Ductility factor	$k_7$	[-]	1,0															
<b>With lever arm</b>																		
Characteristic resistance	$M^0_{Rk,s}$	[Nm]	92			233			454			785						
<b>Partial factor<sup>1)</sup></b>																		
Partial factor	$\gamma_{Ms,V}$	[-]	1,56															
<sup>1)</sup> In absence of other national regulations																		
fischer injection system FIS EM Plus																<b>Annex C 3</b>		
<b>Performance</b> Essential characteristics for the steel bearing capacity of reinforcing bars and fischer rebar anchors FRA																		

Table C4.1: Essential characteristics under tensile / shear load																			
Size		All sizes																	
<b>Tensile load</b>																			
Uncracked concrete	$k_{ucr,N}$	[-]	11,0																
Cracked concrete	$k_{cr,N}$		7,7																
<b>Factors for the compressive strength of concrete &gt; C20/25</b>																			
Increasing factor for $\tau_{RK}$	C25/30	$\Psi_c$	[-]	1,02															
	C30/37			1,04															
	C35/45			1,06															
	C40/50			1,07															
	C45/55			1,08															
	C50/60			1,09															
<b>Splitting failure</b>																			
Edge distance	$h / h_{ef} \geq 2,0$	$C_{cr,sp}$	[mm]	1,0 $h_{ef}$															
	$2,0 > h / h_{ef} > 1,3$			4,6 $h_{ef}$ - 1,8 h															
	$h / h_{ef} \leq 1,3$			2,26 $h_{ef}$															
Spacing	$S_{cr,sp}$			2 $C_{cr,sp}$															
<b>Concrete cone failure</b>																			
Edge distance	$C_{cr,N}$	[mm]	1,5 $h_{ef}$																
Spacing	$S_{cr,N}$		2 $C_{cr,N}$																
<b>Shear load</b>																			
Installation factor	$\gamma_{inst}$	[-]	1,0																
<b>Concrete pry-out failure</b>																			
Factor for pry-out failure	$k_8$	[-]	2,0																
<b>Concrete edge failure</b>																			
The value of $h_{ef}$ (=l <sub>f</sub> ) under shear load		[-]	Conditions according to 1992-4:2018: chapter 7.2.2.5; Section 6; formular 7.43																
<b>Calculation diameters</b>																			
Size			M8	M10	M12	M14	M16	M20	M22	M24	M27	M30							
fischer anchor rods and standard threaded rods	$d_{nom}$	[mm]	8	10	12	14	16	20	22	24	27	30							
fischer internal threaded anchors RG MI	$d_{nom}$		12	16	18	-	22	28	-	-	-	-							
fischer rebar anchor FRA	$d_{nom}$		-	-	12	-	16	20	-	25	-	-							
Size (nominal diameter of the bar)	$\phi$		8	10	12	14	16	18	20	22	24	25	26	28	30	32	34	36	40
Reinforcing bar	$d_{nom}$	[mm]	8	10	12	14	16	18	20	22	24	25	26	28	30	32	34	36	40
fischer injection system FIS EM Plus												<b>Annex C 4</b>							
<b>Performance</b> Essential characteristics under tensile / shear load																			

**Table C5.1:** Essential characteristics of **tensile resistance** for **fischer anchor rods** and **standard threaded rods** in hammer or diamond drilled holes; **uncracked or cracked concrete; service life time 50 years**

Anchor rod / standard threaded rod		M8	M10	M12	M14	M16	M20	M22	M24	M27	M30	
<b>Combined pullout and concrete cone failure</b>												
Calculation diameter	d [mm]	8	10	12	14	16	20	22	24	27	30	
<b>Uncracked concrete</b>												
<b>Characteristic bond resistance in uncracked concrete C20/25</b>												
<u>Hammer-drilling with standard drill bit or hollow drill bit (dry or wet concrete)</u>												
Temperature range	I: 35 °C / 60 °C	$\tau_{Rk,ucr}$ [N/mm <sup>2</sup> ]	18	18	18	17	17	16	15	15	15	14
	II: 50 °C / 72 °C		18	17	17	16	16	15	14	14	14	13
<u>Hammer-drilling with standard drill bit or hollow drill bit (water filled hole)</u>												
Temperature range	I: 35 °C / 60 °C	$\tau_{Rk,ucr}$ [N/mm <sup>2</sup> ]	16	16	15	13	13	11	11	10	10	9
	II: 50 °C / 72 °C		15	14	14	13	12	11	10	10	9	9
<u>Diamond-drilling (dry or wet concrete as well as water filled hole)</u>												
Temperature range	I: 35 °C / 60 °C	$\tau_{Rk,ucr}$ [N/mm <sup>2</sup> ]	16	15	13	12	12	10	10	10	9	9
	II: 50 °C / 72 °C		15	14	12	11	11	10	9	9	8	8
<b>Installation factors</b>												
Dry or wet concrete	$\gamma_{inst}$	[-]	1,0									
Water filled hole			1,4									
<b>Cracked concrete</b>												
<b>Characteristic bond resistance in cracked concrete C20/25</b>												
<u>Hammer-drilling with standard drill bit or hollow drill bit (dry or wet concrete)</u>												
Temperature range	I: 35 °C / 60 °C	$\tau_{Rk,cr}$ [N/mm <sup>2</sup> ]	7,5	7,5	9	8,5	8,5	8,5	8,5	8,5	8,5	8,5
	II: 50 °C / 72 °C		7,5	7,5	9	8,5	8,5	8,5	8,5	8,5	8,5	8,5
<u>Diamond - drilling (dry or wet concrete)</u>												
Temperature range	I: 35 °C / 60 °C	$\tau_{Rk,cr}$ [N/mm <sup>2</sup> ]	7	7	7	7	6	6	7	7	7	7
	II: 50 °C / 72 °C		7	7	7	7	6	6	7	7	7	7
<u>Hammer-drilling with standard drill bit or hollow drill bit and diamond-drilling (water filled hole)</u>												
Temperature range	I: 35 °C / 60 °C	$\tau_{Rk,cr}$ [N/mm <sup>2</sup> ]	6	7,5	7,5	7	6	6	6	6	6	6
	II: 50 °C / 72 °C		6	7	7	7	6	6	6	6	6	6
<b>Installation factors</b>												
Dry or wet concrete	$\gamma_{inst}$	[-]	1,0									
Water filled hole			1,2				1,4					
fischer injection system FIS EM Plus											<b>Annex C 5</b>	
<b>Performance</b> Essential characteristics of tensile resistance for fischer anchor rod and standard threaded rods; service life time 50 years												

<b>Table C6.1: Essential characteristics of tensile resistance for fischer anchor rods and standard threaded rods in hammer or diamond drilled holes; uncracked or cracked concrete; service life time 100 years</b>													
Anchor rod / standard threaded rod		M8	M10	M12	M14	M16	M20	M22	M24	M27	M30		
<b>Combined pullout and concrete cone failure</b>													
Calculation diameter	d	[mm]	8	10	12	14	16	20	22	24	27	30	
<b>Uncracked concrete</b>													
<b>Characteristic bond resistance in uncracked concrete C20/25</b>													
<u>Hammer-drilling with standard drill bit or hollow drill bit (dry or wet concrete)</u>													
Tem- perature range	I: 35 °C / 60 °C		$\tau_{Rk,ucr}$	[N/mm <sup>2</sup> ]	18	18	18	17	17	16	15	15	14
	II: 50 °C / 72 °C				18	17	17	16	16	15	14	14	14
<u>Diamond-drilling (dry or wet concrete)</u>													
Tem- perature range	I: 35 °C / 60 °C		$\tau_{Rk,ucr}$	[N/mm <sup>2</sup> ]	16	15	13	12	12	10	10	10	9
	II: 50 °C / 72 °C				15	14	12	11	11	10	9	9	8
<b>Installation factors</b>													
Dry or wet concrete	$\gamma_{inst}$	[-]	1,0										
Service life time 100 years	I: 35 °C / 60 °C		$\alpha_{100\ years}$	[-]	0,75	0,75	0,75	0,75	0,75	0,75	0,75	0,75	0,75
	II: 50 °C / 72 °C				0,55	0,60	0,60	0,65	0,65	0,65	0,65	0,65	0,65
<b>Cracked concrete</b>													
<b>Characteristic bond resistance in cracked concrete C20/25</b>													
<u>Hammer-drilling with standard drill bit or hollow drill bit (dry or wet concrete)</u>													
Tem- perature range	I: 35 °C / 60 °C		$\tau_{Rk,cr}$	[N/mm <sup>2</sup> ]	7,5	7,5	9	8,5	8,5	8,5	8,5	8,5	8,5
	II: 50 °C / 72 °C				7,5	7,5	9	8,5	8,5	8,5	8,5	8,5	8,5
<u>Diamond - drilling (dry or wet concrete)</u>													
Tem- perature range	I: 35 °C / 60 °C		$\tau_{Rk,cr}$	[N/mm <sup>2</sup> ]	7	7	7	7	6	6	7	7	7
	II: 50 °C / 72 °C				7	7	7	7	6	6	7	7	7
<b>Installation factors</b>													
Dry or wet concrete	$\gamma_{inst}$	[-]	1,0										
Service life time 100 years	I: 35 °C / 60 °C		$\alpha_{100\ years}$	[-]	0,60	0,85	0,80	0,65	0,65	0,65	0,65	0,65	0,65
	II: 50 °C / 72 °C				0,60	0,85	0,80	0,65	0,65	0,65	0,65	0,65	0,65
<p>1) Calculation of characteristic bond resistance in uncracked concrete <math>\tau_{Rk,100\ years,ucr}</math> :</p> $\tau_{Rk,100\ years,ucr} = \alpha_{100\ years} \cdot \tau_{Rk,ucr}$ <p>2) Calculation of characteristic bond resistance in cracked concrete <math>\tau_{Rk,100\ years,cr}</math> :</p> $\tau_{Rk,100\ years,cr} = \alpha_{100\ years} \cdot \tau_{Rk,cr}$													
fischer injection system FIS EM Plus											<b>Annex C 6</b>		
<b>Performance</b> Essential characteristics of tensile resistance for fischer anchor rod and standard threaded rods; service life time 100 years													

**Table C7.1:** Essential characteristics of **tensile resistance** for **fischer internal threaded anchors RG MI** in hammer or diamond drilled holes; **uncracked or cracked concrete; service life time 50 years**

Internal threaded anchor RG MI		M8	M10	M12	M16	M20	
<b>Combined pullout and concrete cone failure</b>							
Calculation diameter	d [mm]	12	16	18	22	28	
<b>Uncracked concrete</b>							
<b>Characteristic bond resistance in uncracked concrete C20/25</b>							
<u>Hammer-drilling with standard drill bit or hollow drill bit (dry or wet concrete)</u>							
Temperature range	I: 35 °C / 60 °C	$\tau_{Rk,ucr}$ [N/mm <sup>2</sup> ]	15	14	14	13	12
	II: 50 °C / 72 °C		14	13	13	12	11
<u>Hammer-drilling with standard drill bit or hollow drill bit (water filled hole)</u>							
Temperature range	I: 35 °C / 60 °C	$\tau_{Rk,ucr}$ [N/mm <sup>2</sup> ]	14	12	12	11	10
	II: 50 °C / 72 °C		13	12	11	10	9
<u>Diamond-drilling (dry or wet concrete as well as water filled hole)</u>							
Temperature range	I: 35 °C / 60 °C	$\tau_{Rk,ucr}$ [N/mm <sup>2</sup> ]	13	12	11	10	9
	II: 50 °C / 72 °C		12	11	10	9	8
<b>Installation factors</b>							
Dry or wet concrete	$\gamma_{inst}$ [-]	[-]	1,0				
Water filled hole			1,4				
<b>Cracked concrete</b>							
<b>Characteristic bond resistance in cracked concrete C20/25</b>							
<u>Hammer-drilling with standard drill bit or hollow drill bit and diamond-drilling (dry or wet concrete)</u>							
Temperature range	I: 35 °C / 60 °C	$\tau_{Rk,cr}$ [N/mm <sup>2</sup> ]	7	6	6	7	7
	II: 50 °C / 72 °C		7	6	6	7	7
<u>Hammer-drilling with standard drill bit or hollow drill bit and diamond-drilling (water filled hole)</u>							
Temperature range	I: 35 °C / 60 °C	$\tau_{Rk,cr}$ [N/mm <sup>2</sup> ]	7	6,5	6	6	6
	II: 50 °C / 72 °C		7	6	6	6	6
<b>Installation factors</b>							
Dry or wet concrete	$\gamma_{inst}$ [-]	[-]	1,0				
Water filled hole			1,2		1,4		
fischer injection system FIS EM Plus						<b>Annex C 7</b>	
<b>Performance</b> Essential characteristics of tensile resistance for fischer internal threaded anchors RG MI; service life time 50 years							

**Table C8.1:** Essential characteristics of **tensile resistance** for **fischer internal threaded anchors RG MI** in hammer or diamond drilled holes; **uncracked or cracked concrete; service life time 100 years**

Internal threaded anchor RG MI		M8	M10	M12	M16	M20		
<b>Combined pullout and concrete cone failure</b>								
Calculation diameter	d [mm]	12	16	18	22	28		
<b>Uncracked concrete</b>								
<b>Characteristic bond resistance in uncracked concrete C20/25</b>								
<u>Hammer-drilling with standard drill bit or hollow drill bit (dry or wet concrete)</u>								
Temperature range	I: 35 °C / 60 °C	$\tau_{RK,ucr}$ [N/mm <sup>2</sup> ]	15	14	14	13	12	
	II: 50 °C / 72 °C		14	13	13	12	11	
<u>Diamond-drilling (dry or wet concrete)</u>								
Temperature range	I: 35 °C / 60 °C	$\tau_{RK,ucr}$ [N/mm <sup>2</sup> ]	13	12	11	10	9	
	II: 50 °C / 72 °C		12	11	10	9	8	
<b>Installation factors</b>								
Dry or wet concrete	$\gamma_{inst}$	[-]	1,0					
Service life time 100 years	I: 35 °C / 60 °C	$\alpha_{100\ years}$	[-]	0,75	0,75	0,75	0,75	0,75
	II: 50 °C / 72 °C			0,55	0,60	0,60	0,65	0,65
<b>Cracked concrete</b>								
<b>Characteristic bond resistance in cracked concrete C20/25</b>								
<u>Hammer-drilling with standard drill bit or hollow drill bit and diamond-drilling (dry or wet concrete)</u>								
Temperature range	I: 35 °C / 60 °C	$\tau_{RK,cr}$ [N/mm <sup>2</sup> ]	7	6	6	7	7	
	II: 50 °C / 72 °C		7	6	6	7	7	
<b>Installation factors</b>								
Dry or wet concrete	$\gamma_{inst}$	[-]	1,0					
Service life time 100 years	I: 35 °C / 60 °C	$\alpha_{100\ years}$	[-]	0,60	0,85	0,80	0,65	0,65
	II: 50 °C / 72 °C			0,60	0,85	0,80	0,65	0,65
<p>1) <b>Calculation of characteristic bond resistance in uncracked concrete <math>\tau_{RK,100\ years,ucr}</math> :</b></p> $\tau_{RK,100\ years,ucr} = \alpha_{100\ years} \cdot \tau_{RK,ucr}$ <p>2) <b>Calculation of characteristic bond resistance in cracked concrete <math>\tau_{RK,100\ years,cr}</math> :</b></p> $\tau_{RK,100\ years,cr} = \alpha_{100\ years} \cdot \tau_{RK,cr}$								
fischer injection system FIS EM Plus						<b>Annex C 8</b>		
<b>Performance</b> Essential characteristics of tensile resistance for fischer internal threaded anchors RG MI; service life time 100 years								

<b>Table C9.1:</b> Essential characteristics of <b>tensile resistance</b> for reinforcing bars in hammer or diamond drilled holes; <b>uncracked or cracked concrete;</b> <b>service life time 50 years</b>																					
Nominal diameter of the bar		$\phi$	8	10	12	14	16	18	20	22	24	25	26	28	30	32	34	36	40		
<b>Combined pullout and concrete cone failure</b>																					
Calculation diameter		d	[mm]	8	10	12	14	16	18	20	22	24	25	26	28	30	32	34	36	40	
<b>Uncracked concrete</b>																					
<b>Characteristic bond resistance in uncracked concrete C20/25</b>																					
Hammer-drilling with standard drill bit or hollow drill bit (dry or wet concrete)																					
Tem- perature range	I: 35 °C / 60 °C		$\tau_{Rk,ucr}$	[N/mm <sup>2</sup> ]	16	15	15	14	14	13	13	13	12	12	12	12	12	11	11	11	
	II: 50 °C / 72 °C				15	14	14	13	13	12	12	12	12	11	11	11	11	11	11	11	10
Hammer-drilling with standard drill bit or hollow drill bit (water filled hole)																					
Tem- perature range	I: 35 °C / 60 °C		$\tau_{Rk,ucr}$	[N/mm <sup>2</sup> ]	16	16	14	13	12	12	11	11	10	10	10	10	9	9	9	8	8
	II: 50 °C / 72 °C				15	14	13	12	12	11	11	10	10	9	9	9	9	9	8	8	8
Diamond-drilling (dry or wet concrete as well as water filled hole)																					
Tem- perature range	I: 35 °C / 60 °C		$\tau_{Rk,ucr}$	[N/mm <sup>2</sup> ]	16	15	13	12	12	11	10	10	10	9	9	9	9	8	8	8	7
	II: 50 °C / 72 °C				15	14	12	11	11	10	10	9	9	9	8	8	8	8	8	7	7
<b>Installation factors</b>																					
Dry or wet concrete		$\gamma_{inst}$	[-]															1,0			
Water filled hole		$\gamma_{inst}$	[-]															1,4			
<b>Cracked concrete</b>																					
<b>Characteristic bond resistance in cracked concrete C20/25</b>																					
Hammer-drilling with standard drill bit or hollow drill bit (dry or wet concrete)																					
Tem- perature range	I: 35 °C / 60 °C		$\tau_{Rk,cr}$	[N/mm <sup>2</sup> ]	7	7	8	8	8	8	8	8	8	8	8	8	8	8	8	8	
	II: 50 °C / 72 °C				7	7	8	8	8	8	8	8	8	8	8	8	8	8	8	8	8
Diamond-drilling (dry or wet concrete)																					
Tem- perature range	I: 35 °C / 60 °C		$\tau_{Rk,cr}$	[N/mm <sup>2</sup> ]	7	7	7	7	6	6	6	7	7	7	7	7	7	5	5	5	5
	II: 50 °C / 72 °C				7	7	7	7	6	6	6	6	7	7	7	7	7	7	5	5	5
Hammer-drilling with standard drill bit or hollow drill bit and diamond-drilling (water filled hole)																					
Tem- perature range	I: 35 °C / 60 °C		$\tau_{Rk,cr}$	[N/mm <sup>2</sup> ]	6	7,5	6,5	6,5	6,5	6	6	6	6	6	6	6	6	5	5	5	5
	II: 50 °C / 72 °C				6	6,5	6,5	6	6	6	6	6	6	6	6	6	6	6	5	5	5
<b>Installation factors</b>																					
Dry or wet concrete		$\gamma_{inst}$	[-]															1,0			
Water filled hole		$\gamma_{inst}$	[-]	1,2							1,4										
fischer injection system FIS EM Plus																					
<b>Performance</b> Essential characteristics of tensile resistance for reinforcing bars; service life time 50 years																					
<b>Annex C 9</b>																					



<b>Table C10.1: Essential characteristics of tensile resistance for reinforcing bars in hammer or diamond drilled holes; uncracked or cracked concrete; service life time 100 years</b>																				
Nominal diameter of the bar $\phi$		8	10	12	14	16	18	20	22	24	25	26	28	30	32	34	36	40		
<b>Combined pullout and concrete cone failure</b>																				
Calculation diameter d		[mm]	8	10	12	14	16	18	20	22	24	25	26	28	30	32	34	36	40	
<b>Uncracked concrete</b>																				
<b>Characteristic bond resistance in uncracked concrete C20/25</b>																				
<u>Hammer-drilling with standard drill bit or hollow drill bit (dry or wet concrete)</u>																				
Tem- perature range	I: 35 °C / 60 °C		$\tau_{Rk,ucr}$	[N/mm <sup>2</sup> ]	16	15	15	14	14	13	13	13	12	12	12	12	12	11	11	11
	II: 50 °C / 72 °C				15	14	14	13	13	12	12	12	12	11	11	11	11	11	11	10
<u>Diamond-drilling (dry or wet concrete)</u>																				
Tem- perature range	I: 35 °C / 60 °C		$\tau_{Rk,ucr}$	[N/mm <sup>2</sup> ]	16	15	13	12	12	11	10	10	10	9	9	9	8	8	8	7
	II: 50 °C / 72 °C				15	14	12	11	11	10	10	9	9	9	8	8	8	8	7	7
<b>Installation factors</b>																				
Dry or wet concrete		$\gamma_{inst}$	[-]	1,0																
Service life time 100 years	I: 35 °C / 60 °C		$\alpha_{100\ years}$	[-]	0,75	0,75	0,75	0,75	0,75	0,75	0,75	0,75	0,75	0,75	0,75	0,75	0,75	0,75	0,75	
	II: 50 °C / 72 °C				0,55	0,60	0,60	0,65	0,65	0,65	0,65	0,65	0,65	0,65	0,65	0,65	0,65	0,65	0,65	0,65
<b>Cracked concrete</b>																				
<b>Characteristic bond resistance in cracked concrete C20/25</b>																				
<u>Hammer-drilling with standard drill bit or hollow drill bit (dry or wet concrete)</u>																				
Tem- perature range	I: 35 °C / 60 °C		$\tau_{Rk,cr}$	[N/mm <sup>2</sup> ]	7	7	8	8	8	8	8	8	8	8	8	8	8	8	8	
	II: 50 °C / 72 °C				7	7	8	8	8	8	8	8	8	8	8	8	8	8	8	8
<u>Diamond-drilling (dry or wet concrete)</u>																				
Tem- perature range	I: 35 °C / 60 °C		$\tau_{Rk,cr}$	[N/mm <sup>2</sup> ]	7	7	7	7	6	6	6	7	7	7	7	7	5	5	5	5
	II: 50 °C / 72 °C				7	7	7	7	6	6	6	7	7	7	7	7	7	5	5	5
<b>Installation factors</b>																				
Dry or wet concrete		$\gamma_{inst}$	[-]	1,0																
Service life time 100 years	I: 35 °C / 60 °C		$\alpha_{100\ years}$	[-]	0,60	0,85	0,80	0,65	0,65	0,65	0,65	0,65	0,65	0,65	0,65	0,65	0,65	0,65	0,65	
	II: 50 °C / 72 °C				0,60	0,85	0,80	0,65	0,65	0,65	0,65	0,65	0,65	0,65	0,65	0,65	0,65	0,65	0,65	0,65
<p>1) Calculation of characteristic bond resistance in uncracked concrete <math>\tau_{Rk,100\ years,ucr}</math> :</p> $\tau_{Rk,100\ years,ucr} = \alpha_{100\ years} \cdot \tau_{Rk,ucr}$ <p>2) Calculation of characteristic bond resistance in cracked concrete <math>\tau_{Rk,100\ years,cr}</math> :</p> $\tau_{Rk,100\ years,cr} = \alpha_{100\ years} \cdot \tau_{Rk,cr}$																				
fischer injection system FIS EM Plus														<b>Annex C 10</b>						
<b>Performance</b> Essential characteristics of tensile resistance for reinforcing bars; service life time 100 years																				

<b>Table C11.1: Essential characteristics of tensile resistance for fischer rebar anchors FRA in hammer or diamond drilled holes; uncracked or cracked concrete; service life time 50 years</b>						
fischer rebar anchor FRA			M12	M16	M20	M24
<b>Combined pullout and concrete cone failure</b>						
Calculation diameter	d	[mm]	12	16	20	25
<b>Uncracked concrete</b>						
<b>Characteristic bond resistance in uncracked concrete C20/25</b>						
<u>Hammer-drilling with standard drill bit or hollow drill bit (dry or wet concrete)</u>						
Temperature range	I: 35 °C / 60 °C	$\tau_{Rk,ucr}$ [N/mm <sup>2</sup> ]	15	14	13	12
	II: 50 °C / 72 °C		14	13	12	12
<u>Hammer-drilling with standard drill bit or hollow drill bit (water filled hole)</u>						
Temperature range	I: 35 °C / 60 °C	$\tau_{Rk,ucr}$ [N/mm <sup>2</sup> ]	14	12	11	10
	II: 50 °C / 72 °C		13	12	11	9
<u>Diamond-drilling (dry or wet concrete as well as water filled hole)</u>						
Temperature range	I: 35 °C / 60 °C	$\tau_{Rk,ucr}$ [N/mm <sup>2</sup> ]	13	12	10	9
	II: 50 °C / 72 °C		12	11	10	9
<b>Installation factors</b>						
Dry or wet concrete	$\gamma_{inst}$	[-]	1,0			
Water filled hole			1,4			
<b>Cracked concrete</b>						
<b>Characteristic bond resistance in cracked concrete C20/25</b>						
<u>Hammer-drilling with standard drill bit or hollow drill bit and diamond-drilling (dry or wet concrete)</u>						
Temperature range	I: 35 °C / 60 °C	$\tau_{Rk,cr}$ [N/mm <sup>2</sup> ]	8	8	8	8
	II: 50 °C / 72 °C		8	8	8	8
<u>Hammer-drilling with standard drill bit or hollow drill bit and diamond-drilling (water filled hole)</u>						
Temperature range	I: 35 °C / 60 °C	$\tau_{Rk,cr}$ [N/mm <sup>2</sup> ]	7	6	6	6
	II: 50 °C / 72 °C		7	6	6	6
<b>Installation factors</b>						
Dry or wet concrete	$\gamma_{inst}$	[-]	1,0			
Water filled hole			1,2	1,4		
fischer injection system FIS EM Plus					<b>Annex C 11</b>	
<b>Performance</b> Essential characteristics of tensile resistance for fischer rebar anchors FRA; service life time 50 years						

<b>Table C12.1: Essential characteristics of tensile resistance for fischer rebar anchors FRA in hammer or diamond drilled holes; uncracked or cracked concrete; service life time 100 years</b>						
fischer rebar anchor FRA		M12	M16	M20	M24	
<b>Combined pullout and concrete cone failure</b>						
Calculation diameter	d	[mm]	12	16	20	25
<b>Uncracked concrete</b>						
<b>Characteristic bond resistance in uncracked concrete C20/25</b>						
<u>Hammer-drilling with standard drill bit or hollow drill bit (dry or wet concrete)</u>						
Tem- perature range	I: 35 °C / 60 °C		$\tau_{Rk,ucr}$	[N/mm <sup>2</sup> ]	15	14
	II: 50 °C / 72 °C				13	12
Tem- perature range	I: 35 °C / 60 °C		$\tau_{Rk,ucr}$	[N/mm <sup>2</sup> ]	13	12
	II: 50 °C / 72 °C				11	10
<u>Diamond-drilling (dry or wet concrete)</u>						
Tem- perature range	I: 35 °C / 60 °C		$\tau_{Rk,ucr}$	[N/mm <sup>2</sup> ]	13	12
	II: 50 °C / 72 °C				12	11
<b>Installation factors</b>						
Dry or wet concrete	$\gamma_{inst}$	[-]	1,0			
Service life time 100 years	I: 35 °C / 60 °C		$\alpha_{100\ years}$	[N/mm <sup>2</sup> ]	0,75	0,75
	II: 50 °C / 72 °C				0,60	0,65
<b>Cracked concrete</b>						
<b>Characteristic bond resistance in cracked concrete C20/25</b>						
<u>Hammer-drilling with standard drill bit or hollow drill bit and diamond-drilling (dry or wet concrete)</u>						
Tem- perature range	I: 35 °C / 60 °C		$\tau_{Rk,cr}$	[N/mm <sup>2</sup> ]	8	8
	II: 50 °C / 72 °C				8	8
<b>Installation factors</b>						
Dry or wet concrete	$\gamma_{inst}$	[-]	1,0			
Service life time 100 years	I: 35 °C / 60 °C		$\alpha_{100\ years}$	[-]	0,80	0,65
	II: 50 °C / 72 °C				0,80	0,65
<p>1) <b>Calculation of characteristic bond resistance in uncracked concrete <math>\tau_{Rk,100\ years,ucr}</math> :</b></p> $\tau_{Rk,100\ years,ucr} = \alpha_{100\ years} \cdot \tau_{Rk,ucr}$ <p>2) <b>Calculation of characteristic bond resistance in cracked concrete <math>\tau_{Rk,100\ years,cr}</math> :</b></p> $\tau_{Rk,100\ years,cr} = \alpha_{100\ years} \cdot \tau_{Rk,cr}$						
fischer injection system FIS EM Plus					<b>Annex C 12</b>	
<b>Performance</b> Essential characteristics of tensile resistance for fischer rebar anchors FRA; service life time 100 years						

<b>Table C13.1: Displacements for anchor rods</b>											
Anchor rod		M8	M10	M12	M14	M16	M20	M22	M24	M27	M30
<b>Displacement-Factors for tensile load<sup>1)</sup></b>											
<b>Uncracked or cracked concrete; Temperature range I, II</b>											
$\delta_{N0}$ -Factor	[mm/(N/mm <sup>2</sup> )]	0,07	0,08	0,09	0,09	0,10	0,11	0,11	0,12	0,12	0,13
$\delta_{N\infty}$ -Factor		0,11	0,12	0,13	0,14	0,15	0,16	0,17	0,18	0,19	0,19
<b>Displacement-Factors for shear load<sup>2)</sup></b>											
<b>Uncracked or cracked concrete; Temperature range I, II</b>											
$\delta_{V0}$ -Factor	[mm/kN]	0,18	0,15	0,12	0,10	0,09	0,07	0,07	0,06	0,05	0,05
$\delta_{V\infty}$ -Factor		0,27	0,22	0,18	0,16	0,14	0,11	0,10	0,09	0,08	0,07
1) Calculation of effective displacement: $\delta_{N0} = \delta_{N0\text{-Factor}} \cdot \tau_{Ed}$ $\delta_{N\infty} = \delta_{N\infty\text{-Factor}} \cdot \tau_{Ed}$ ( $\tau_{Ed}$ : Design value of the applied tensile stress)						2) Calculation of effective displacement: $\delta_{V0} = \delta_{V0\text{-Factor}} \cdot V_{Ed}$ $\delta_{V\infty} = \delta_{V\infty\text{-Factor}} \cdot V_{Ed}$ ( $V_{Ed}$ : Design value of the applied shear force)					
<b>Table C13.2: Displacements for fischer internal threaded anchors RG MI</b>											
Internal threaded anchor RG MI		M8	M10	M12	M16	M20					
<b>Displacement-Factors for tensile load<sup>1)</sup></b>											
<b>Uncracked or cracked concrete; Temperature range I, II</b>											
$\delta_{N0}$ -Factor	[mm/(N/mm <sup>2</sup> )]	0,09	0,10	0,10	0,11	0,13					
$\delta_{N\infty}$ -Factor		0,13	0,15	0,16	0,17	0,19					
<b>Displacement-Factors for shear load<sup>2)</sup></b>											
<b>Uncracked or cracked concrete; Temperature range I, II</b>											
$\delta_{V0}$ -Factor	[mm/kN]	0,12	0,09	0,08	0,07	0,05					
$\delta_{V\infty}$ -Factor		0,18	0,14	0,12	0,10	0,08					
1) Calculation of effective displacement: $\delta_{N0} = \delta_{N0\text{-Factor}} \cdot \tau_{Ed}$ $\delta_{N\infty} = \delta_{N\infty\text{-Factor}} \cdot \tau_{Ed}$ ( $\tau_{Ed}$ : Design value of the applied tensile stress)						2) Calculation of effective displacement: $\delta_{V0} = \delta_{V0\text{-Factor}} \cdot V_{Ed}$ $\delta_{V\infty} = \delta_{V\infty\text{-Factor}} \cdot V_{Ed}$ ( $V_{Ed}$ : Design value of the applied shear force)					
fischer injection system FIS EM Plus										<b>Annex C 13</b>	
<b>Performance</b> Displacements for anchor rods and fischer internal threaded anchors RG MI											

<b>Table C14.1: Displacements for reinforcing bars</b>																		
Nominal diameter of the bar $\phi$	8	10	12	14	16	18	20	22	24	25	26	28	30	32	34	36	40	
<b>Displacement-Factors for tensile load<sup>1)</sup></b>																		
<b>Uncracked or cracked concrete; Temperature range I, II</b>																		
$\delta_{N0}$ -Factor	[mm/(N/mm <sup>2</sup> )]	0,07	0,08	0,09	0,09	0,10	0,10	0,11	0,11	0,12	0,12	0,12	0,13	0,13	0,13	0,14	0,14	0,15
$\delta_{N\infty}$ -Factor		0,11	0,12	0,13	0,14	0,15	0,16	0,16	0,17	0,18	0,18	0,18	0,19	0,19	0,20	0,20	0,21	0,22
<b>Displacement-Factors for shear load<sup>2)</sup></b>																		
<b>Uncracked or cracked concrete; Temperature range I, II</b>																		
$\delta_{V0}$ -Factor	[mm/kN]	0,18	0,15	0,12	0,10	0,09	0,08	0,07	0,07	0,06	0,06	0,06	0,05	0,05	0,05	0,04	0,04	0,04
$\delta_{V\infty}$ -Factor		0,27	0,22	0,18	0,16	0,14	0,12	0,11	0,10	0,09	0,09	0,08	0,08	0,07	0,07	0,06	0,06	0,05
1) Calculation of effective displacement: $\delta_{N0} = \delta_{N0}\text{-Factor} \cdot \tau_{Ed}$ $\delta_{N\infty} = \delta_{N\infty}\text{-Factor} \cdot \tau_{Ed}$ ( $\tau_{Ed}$ : Design value of the applied tensile stress)										2) Calculation of effective displacement: $\delta_{V0} = \delta_{V0}\text{-Factor} \cdot V_{Ed}$ $\delta_{V\infty} = \delta_{V\infty}\text{-Factor} \cdot V_{Ed}$ ( $V_{Ed}$ : Design value of the applied shear force)								
<b>Table C14.2: Displacements for fischer rebar anchors FRA</b>																		
fischer rebar anchor FRA	M12				M16				M20				M24					
<b>Displacement-Factors for tensile load<sup>1)</sup></b>																		
<b>Uncracked or cracked concrete; Temperature range I, II</b>																		
$\delta_{N0}$ -Factor	[mm/(N/mm <sup>2</sup> )]	0,09				0,10				0,11				0,12				
$\delta_{N\infty}$ -Factor		0,13				0,15				0,16				0,18				
<b>Displacement-Factors for shear load<sup>2)</sup></b>																		
<b>Uncracked or cracked concrete; Temperature range I, II</b>																		
$\delta_{V0}$ -Factor	[mm/kN]	0,12				0,09				0,07				0,06				
$\delta_{V\infty}$ -Factor		0,18				0,14				0,11				0,09				
1) Calculation of effective displacement: $\delta_{N0} = \delta_{N0}\text{-Factor} \cdot \tau_{Ed}$ $\delta_{N\infty} = \delta_{N\infty}\text{-Factor} \cdot \tau_{Ed}$ ( $\tau_{Ed}$ : Design value of the applied tensile stress)										2) Calculation of effective displacement: $\delta_{V0} = \delta_{V0}\text{-Factor} \cdot V_{Ed}$ $\delta_{V\infty} = \delta_{V\infty}\text{-Factor} \cdot V_{Ed}$ ( $V_{Ed}$ : Design value of the applied shear force)								
fischer injection system FIS EM Plus															<b>Annex C 14</b>			
<b>Performance</b> Displacements for reinforcing bars and fischer rebar anchors FRA																		

**Table C15.1:** Essential characteristics<sup>2)</sup> for the **steel bearing capacity** under tensile / shear load of **fischer anchor rods** and **standard threaded rods** under seismic action performance category **C1** or **C2**

Anchor rod / standard threaded rod		M10	M12	M14	M16	M20	M22	M24	M27	M30	
<b>Bearing capacity under tensile load, steel failure<sup>1)</sup></b>											
<b>fischer anchor rods and standard threaded rods, performance category C1</b>											
Characteristic resistance $N_{Rk,s,eq,C1}$	Steel zinc plated	5.8	29(27)	43	58	79	123	152	177	230	281
		8.8	47(43)	68	92	126	196	243	282	368	449
	Stainless steel A4 and high corrosion resistant steel C	50	29	43	58	79	123	152	177	230	281
		70	41	59	81	110	172	212	247	322	393
		80	47	68	92	126	196	243	282	368	449
<b>fischer anchor rods and standard threaded rods, performance category C2</b>											
Characteristic resistance $N_{Rk,s,eq,C2}$	Steel zinc plated	5.8	-	39	-	72	108	-	177	-	-
		8.8	-	61	-	116	173	-	282	-	-
	Stainless steel A4 and high corrosion resistant steel C	50	-	39	-	72	108	-	177	-	-
		70	-	53	-	101	152	-	247	-	-
		80	-	61	-	116	173	-	282	-	-
<b>Bearing capacity under shear load, steel failure without lever arm<sup>1)</sup></b>											
<b>fischer anchor rods, performance category C1</b>											
Characteristic resistance $V_{Rk,s,eq,C1}^0$	Steel zinc plated	5.8	15(13)	21	29	39	61	76	89	115	141
		8.8	23(21)	34	46	63	98	122	141	184	225
	Stainless steel A4 and high corrosion resistant steel C	50	15	21	29	39	61	76	89	115	141
		70	20	30	40	55	86	107	124	161	197
		80	23	34	46	63	98	122	141	184	225
<b>Standard threaded rods, performance category C1</b>											
Characteristic resistance $V_{Rk,s,eq,C1}^0$	Steel zinc plated	5.8	11(9)	15	20	27	43	53	62	81	99
		8.8	16(14)	24	32	44	69	85	99	129	158
	Stainless steel A4 and high corrosion resistant steel C	50	11	15	20	27	43	53	62	81	99
		70	14	21	28	39	60	75	87	113	138
		80	16	24	32	44	69	85	99	129	158
<b>fischer anchor rods and standard threaded rods, performance category C2</b>											
Characteristic resistance $V_{Rk,s,eq,C2}^0$	Steel zinc plated	5.8	-	14	-	27	43	-	62	-	-
		8.8	-	22	-	44	69	-	99	-	-
	Stainless steel A4 and high corrosion resistant steel C	50	-	14	-	27	43	-	62	-	-
		70	-	20	-	39	60	-	87	-	-
		80	-	22	-	44	69	-	99	-	-
<sup>1)</sup> Partial factors for performance category C1 or C2 see table C16.2; for fischer anchor rods FIS A / RGM the factor for steel ductility is 1,0 <sup>2)</sup> Values in brackets are valid for undersized threaded rods with smaller stress area $A_s$ for hot dip galvanized standard threaded rods according to EN ISO 10684:2004+AC:2009.											
fischer injection system FIS EM Plus										<b>Annex C 15</b>	
<b>Performance</b> Essential characteristics for the steel bearing capacity for fischer anchor rods and standard threaded rods under seismic action (performance category C1 / C2)											

**Table C16.1:** Essential characteristics for the **steel bearing capacity** under tensile / shear load of **reinforcing bars (B500B)** under seismic action performance category **C1**

Nominal diameter of the bar	$\phi$	10	12	14	16	18	20	22	24	25	26	28	30	32
<b>Bearing capacity under tensile load, steel failure<sup>1)</sup></b>														
<b>Reinforcing bar B500B acc. to DIN 488-2:2009-08, performance category C1</b>														
Characteristic resistance	$N_{Rk,s,eq,C1}$ [kN]	44	63	85	111	140	173	209	249	270	292	339	389	443
<b>Bearing capacity under shear load, steel failure without lever arm<sup>1)</sup></b>														
<b>Reinforcing bar B500B acc. to DIN 488-2:2009-08, performance category C1</b>														
Characteristic resistance	$V^0_{Rk,s,eq,C1}$ [kN]	15	22	30	39	49	61	74	88	95	102	119	137	155

<sup>1)</sup> Partial factors for performance category C1 see table C16.2

**Table C16.2:** Partial factors for **fischer anchor rods, standard threaded rods** and **reinforcing bars (B500B)** under seismic action performance category **C1 or C2**

Anchor rod / standard threaded rod		M10	M12	M14	M16	M20	M22	M24	M27	M30			
Nominal diameter of the bar	$\phi$	10	12	14	16	18	20	24	25	26	28	30	32
<b>Tensile load, steel failure<sup>1)</sup></b>													
Partial factor $\gamma_{Ms,N}$	Steel zinc plated	5.8	1,50										
		8.8	1,50										
	Stainless steel A4 and high corrosion resistant steel C	50	2,86										
		70	1,50 <sup>2)</sup> / 1,87										
		80	1,60										
	Reinforcing bar	B500B	1,40										
<b>Shear load, steel failure<sup>1)</sup></b>													
Partial factor $\gamma_{Ms,V}$	Steel zinc plated	5.8	1,25										
		8.8	1,25										
	Stainless steel A4 and high corrosion resistant steel C	50	2,38										
		70	1,25 <sup>2)</sup> / 1,56										
		80	1,33										
	Reinforcing bar	B500B	1,50										

<sup>1)</sup> In absence of other national regulations

<sup>2)</sup> Only admissible for high corrosion resistant steel C, with  $f_{yk} / f_{uk} \geq 0,8$  and  $A_5 > 12\%$  (e.g. fischer anchor rods)

fischer injection system FIS EM Plus

**Performance**

Essential characteristics for the steel bearing capacity for reinforcing bars under seismic action (performance category C1); partial safety factors (performance category C1 / C2)

**Annex C 16**

<b>Table C17.1: Essential characteristics of resistance for fischer anchor rods and standard threaded rods in hammer drilled holes under seismic action performance category C1; service life time 50 and 100 years</b>															
Anchor rod / standard threaded rod		M10	M12	M14	M16	M20	M22	M24	M27	M30					
<b>Characteristic bond resistance, combined pullout and concrete cone failure</b>															
<b>Hammer-drilling with standard drill bit or hollow drill bit (dry or wet concrete)</b>															
Temperature range	I: 35 °C / 60 °C	$\tau_{RK,eq,C1}$ [N/mm <sup>2</sup> ]	7,0	7,0	6,7	6,0	5,7	6,7	6,7	6,7	6,7				
	II: 50 °C / 72 °C		7,0	7,0	6,7	5,7	5,7	6,7	6,7	6,7	6,7				
<b>Hammer-drilling with standard drill bit or hollow drill bit (water filled hole)</b>															
Temperature range	I: 35 °C / 60 °C	$\tau_{RK,eq,C1}$ [N/mm <sup>2</sup> ]	7,5	7,5	6,5	5,7	5,7	5,7	5,7	5,7	5,7				
	II: 50 °C / 72 °C		6,8	6,8	6,5	5,7	5,7	5,7	5,7	5,7	5,7				
<b>Installation factors</b>															
<b>tensile load</b>															
Dry or wet concrete		$\gamma_{inst}$	[-]	1,0											
Water filled hole				1,2				1,4							
<b>shear load</b>															
All installation conditions		$\gamma_{inst}$	[-]	1,0											
<b>Table C17.2: Essential characteristics of resistance for reinforcing bars in hammer drilled holes under seismic action performance category C1; service life time 50 and 100 years</b>															
Nominal diameter of the bar		$\phi$	10	12	14	16	18	20	22	24	25	26	28	30	32
<b>Characteristic bond resistance, combined pullout and concrete cone failure</b>															
<b>Hammer-drilling with standard drill bit or hollow drill bit (dry or wet concrete)</b>															
Temperature range	I: 35 °C / 60 °C	$\tau_{RK,eq,C1}$ [N/mm <sup>2</sup> ]	7,0	7,0	6,7	5,7	5,7	5,7	6,7	6,7	6,7	6,7	6,7	6,7	4,8
	II: 50 °C / 72 °C		7,0	7,0	6,7	5,7	5,7	5,7	6,7	6,7	6,7	6,7	6,7	6,7	6,7
<b>Hammer-drilling with standard drill bit or hollow drill bit (water filled hole)</b>															
Temperature range	I: 35 °C / 60 °C	$\tau_{RK,eq,C1}$ [N/mm <sup>2</sup> ]	7,5	6,5	6,5	5,7	5,7	5,7	5,7	5,7	5,7	5,7	5,7	5,7	4,8
	II: 50 °C / 72 °C		6,5	6,5	5,8	5,8	5,7	5,7	5,7	5,7	5,7	5,7	5,7	5,7	5,7
<b>Installation factors</b>															
<b>Tensile load</b>															
Dry or wet concrete		$\gamma_{inst}$	[-]	1,0											
Water filled hole				1,2				1,4							
<b>Shear load</b>															
All installation conditions		$\gamma_{inst}$	[-]	1,0											
fischer injection system FIS EM Plus												<b>Annex C 17</b>			
<b>Performance</b> Essential characteristics under seismic action (perfor. category C1) for fischer anchor rods, standard threaded rods and reinforcing bars; service life time 50 and 100 years															



<b>Table C18.1: Essential characteristics of resistance for fischer anchor rods and standard threaded rods in hammer drilled holes under seismic action performance category C2; service life time 50 and 100 years</b>						
Anchor rod / standard threaded rod		M12	M16	M20	M24	
<b>Characteristic bond resistance, combined pullout and concrete cone failure</b>						
<b>Hammer-drilling with standard drill bit or hollow drill bit (dry or wet concrete)</b>						
Tem- perature range	I: 35 °C / 60 °C	$\tau_{Rk,eq,C2}$ [N/mm <sup>2</sup> ]	3,5	5,8	5,0	3,1
	II: 50 °C / 72 °C		3,3	5,5	4,7	2,9
<b>Hammer-drilling with standard drill bit or hollow drill bit (water filled hole)</b>						
Tem- perature range	I: 35 °C / 60 °C	$\tau_{Rk,eq,C2}$ [N/mm <sup>2</sup> ]	3,5	5,8	5,0	3,1
	II: 50 °C / 72 °C		3,3	5,5	4,7	2,9
<b>Installation factors</b>						
<b>Tensile load</b>						
Dry or wet concrete		$\gamma_{inst}$	[-]	1,0		
Water filled hole				1,2	1,4	
<b>Shear load</b>						
All installation conditions		$\gamma_{inst}$	[-]	1,0		
<b>Displacement-Factors for tensile load<sup>1)</sup></b>						
$\delta_{N,(DLS)}$ -Factor		[mm/(N/mm <sup>2</sup> )]	0,09	0,10	0,11	0,12
$\delta_{N,(ULS)}$ -Factor			0,15	0,17	0,17	0,18
<b>Displacement-Factors for shear load<sup>2)</sup></b>						
$\delta_{V,(DLS)}$ -Factor		[mm/kN]	0,18	0,10	0,07	0,06
$\delta_{V,(ULS)}$ -Factor			0,25	0,14	0,11	0,09
1) Calculation of effective displacement: $\delta_{N,(DLS)} = \delta_{N,(DLS)\text{-Factor}} \cdot \tau_{Ed}$ $\delta_{N,(ULS)} = \delta_{N,(ULS)\text{-Factor}} \cdot \tau_{Ed}$ ( $\tau_{Ed}$ : Design value of the applied tensile stress)			2) Calculation of effective displacement: $\delta_{V,(DLS)} = \delta_{V,(DLS)\text{-Factor}} \cdot V_{Ed}$ $\delta_{V,(ULS)} = \delta_{V,(ULS)\text{-Factor}} \cdot V_{Ed}$ ( $V_{Ed}$ : Design value of the applied shear force)			
fischer injection system FIS EM Plus					<b>Annex C 18</b>	
<b>Performance</b> Essential characteristics under seismic action (performance category C2) for fischer anchor rods and standard threaded rods; service life time 50 and 100 years						