

Approval body for construction products
and types of construction

Bautechnisches Prüfamt

An institution established by the Federal and
Laender Governments



European Technical Assessment

ETA-18/0390
of 15 July 2019

English translation prepared by DIBt - Original version in German language

General Part

Technical Assessment Body issuing the
European Technical Assessment:

Deutsches Institut für Bautechnik

Trade name of the construction product

Hanex facade panel

Product family
to which the construction product belongs

Ventilated cladding kit comprising "Hanex facade panel"
and associated fixing

Manufacturer

Hyundai L & C Europe GmbH
Düsseldorfer Straße 13
65760 Eschborn
DEUTSCHLAND

Manufacturing plant

Plant 1

This European Technical Assessment
contains

17 pages including 12 annexes which form an integral
part of this assessment

This European Technical Assessment is
issued in accordance with Regulation (EU)
No 305/2011, on the basis of

EAD 090062-00-0404

The European Technical Assessment is issued by the Technical Assessment Body in its official language. Translations of this European Technical Assessment in other languages shall fully correspond to the original issued document and shall be identified as such.

Communication of this European Technical Assessment, including transmission by electronic means, shall be in full. However, partial reproduction may only be made with the written consent of the issuing Technical Assessment Body. Any partial reproduction shall be identified as such.

This European Technical Assessment may be withdrawn by the issuing Technical Assessment Body, in particular pursuant to information by the Commission in accordance with Article 25(3) of Regulation (EU) No 305/2011.

Specific Part

1 Technical description of the product

Hanex Façade kit for ventilated external wall claddings complies with the family B of EAD 090062-00-0404. The cladding kit consist of white acrylic-based cladding elements (façade panel) mechanically fastened to the subframe by a specific anchor placed in an undercut hole and anchored by mechanical interlock (at least 4 anchors) as listed in section 2 of this document.

The "Hanex façade panel" is a solid surface made of one-third of acrylic resin and two-third of natural mineral aluminium hydroxide with white colour and a thickness of 12 mm.

The product description is given in Annex A.

Hanex Façade kit for ventilated external wall claddings consists of:

- Cladding element: Hanex façade panel (Hanex Premium Surface element, S-008 N-White), white, max. standard formats of acrylic-based cladding elements 930 x 3680 x 12 mm (smaller tiles may be used).
- Cladding fixing: stainless steel KEIL undercut anchor KH 7,0 according to ETA 06/0253 (KH 7)
- Mechanical fastener: The KEIL undercut anchor KH 7,0 according to ETA 06/0253 (KH 7,0) is a special anchor made of stainless steel, consisting of a crosswise slotted anchor sleeve with an M6 internal thread, at the upper edge of which a hexagon is formed to it and a respective hexagon bolt with an integrated tooth lock washer.

Detailed information and data of all the components are given in the annexes of this ETA and in the associated test reports to this ETA.

The subframe, brackets and other fixings between brackets and substrate are not part of the kit assessed in this ETA.

2 Specification of the intended use in accordance with the applicable European Assessment Document

Hanex Façade kit is intended to be used as external wall claddings in ventilated façades (rainscreens). The walls are made of masonry (clay, concrete or stone), concrete (cast on site or as prefabricated panels), timber or metal frame in new or existing buildings (retrofit).

The anchor is put into an undercut drill hole and by driving-in the screw it is placed form-fitted and deformation-controlled.

The vertical load-bearing profiles and horizontal profiles with associated agraffe elements must be metallic elements.

The characteristics of the walls shall be verified prior to use of Hanex Façade kit, especially regarding conditions for reaction to fire classification and for mechanical fixing of Hanex Façade kit.

The performances given in Section 3 are only valid if the anchor is used in compliance with the specifications and conditions given in Annex B.

The provisions made in this European Technical Assessment are based on an assumed working life of at least 25 years for Hanex Façade kit. The indications given on the working life cannot be interpreted as a guarantee given by the producer, but are to be regarded only as a means for choosing the right products in relation to the expected economically reasonable working life of the works.

Hanex Façade kit is made of non-load bearing construction components. They do not contribute directly to the stability of the wall on which they are installed, but they can contribute to its durability by providing enhanced protection from the effect of weathering.

Hanex Façade kit is not intended to ensure the airtightness of the building envelope.

3 Performance of the product and references to the methods used for its assessment

3.1 Safety in case of fire (BWR 2)

Essential characteristic	Performance
Reaction to fire (façade panel) ¹	B-s1, d0 accord. to EN 13501-1
Façade fire performance	No performance assessed
Propensity to undergo continuous smouldering	No performance assessed

Note: A European reference fire scenario has not been laid down for façades. In some Member States, the classification of external wall claddings according to EN 13501-1 might not be sufficient for the use in façades. An additional assessment of external wall claddings according to national provisions (e.g. on the basis of a large-scale test) might be necessary to comply with Member State regulations, until the existing European classification system has been completed.

3.2 Hygiene, health and the environment (BWR 3)

Essential characteristic	Performance
Watertightness of joints	No performance assessed
Waterabsorption	Not relevant
Water vapour permeability	Not relevant
Drainability	No performance assessed
Content, emission and/or release of dangerous substances	No performance assessed

3.3 Safety and accessibility in use (BWR 4)

Essential characteristic	Performance	
Wind load resistance (for the assembled kit)	No performance assessed	
Resistance to horizontal points load	No performance assessed	
Impact resistance	No performance assessed	
Mechanical resistance Family B	Cladding element	See Annex C 1
	Connection between the cladding element and its fixing	See Annex C 1
	Cladding fixing	See Annex C 1

¹ If the conditions mentioned in Annex B1 are fulfilled.

3.4 Protection against noise (BWR 5)

Essential characteristic	Performance
Airborne sound insulation	Not relevant

3.5 Energy economy and heat retention (BWR 6)

Essential characteristic	Performance
Thermal resistance	No performance assessed

3.6 Aspects of durability and serviceability

Essential characteristic	Performance
Behaviour after pulsating load	See Annex C 1
Dimensional stability of external cladding element	No performance assessed
Behaviour after Immersion in water	See Annex C 1
Freeze-thaw resistance	See Annex C 1
Chemical and biological resistance	No performance assessed
Corrosion	No performance assessed
UV radiation resistance	No performance assessed
Hygrothermal behaviour	No performance assessed

4 Assessment and verification of constancy of performance (AVCP) system applied, with reference to its legal base

In accordance with EAD 090062-00-0404, July 2018 the applicable European legal act is: [2003/640/EC].

System of attestation of conformity applicable to cladding kit is: 2+ for any use except for uses subject to regulations on reaction² to fire.

For uses subject to regulations on reaction to fire the applicable AVCP systems regarding reaction to fire are 1, or 3, or 4 depending on the conditions defined in the said Decision.

5 Technical details necessary for the implementation of the AVCP system, as provided for in the applicable EAD

Technical details necessary for the implementation of the AVCP system are laid down in the control plan deposited with Deutsches Institut für Bautechnik.

Issued in Berlin on 15 July 2019 by Deutsches Institut für Bautechnik

BD Dipl.-Ing. Andreas Kummerow
Head of Department

beglaubigt:
F. Beckmann

² Including propensity to undergo continuous shouldering, where relevant.

Kit for external wall cladding

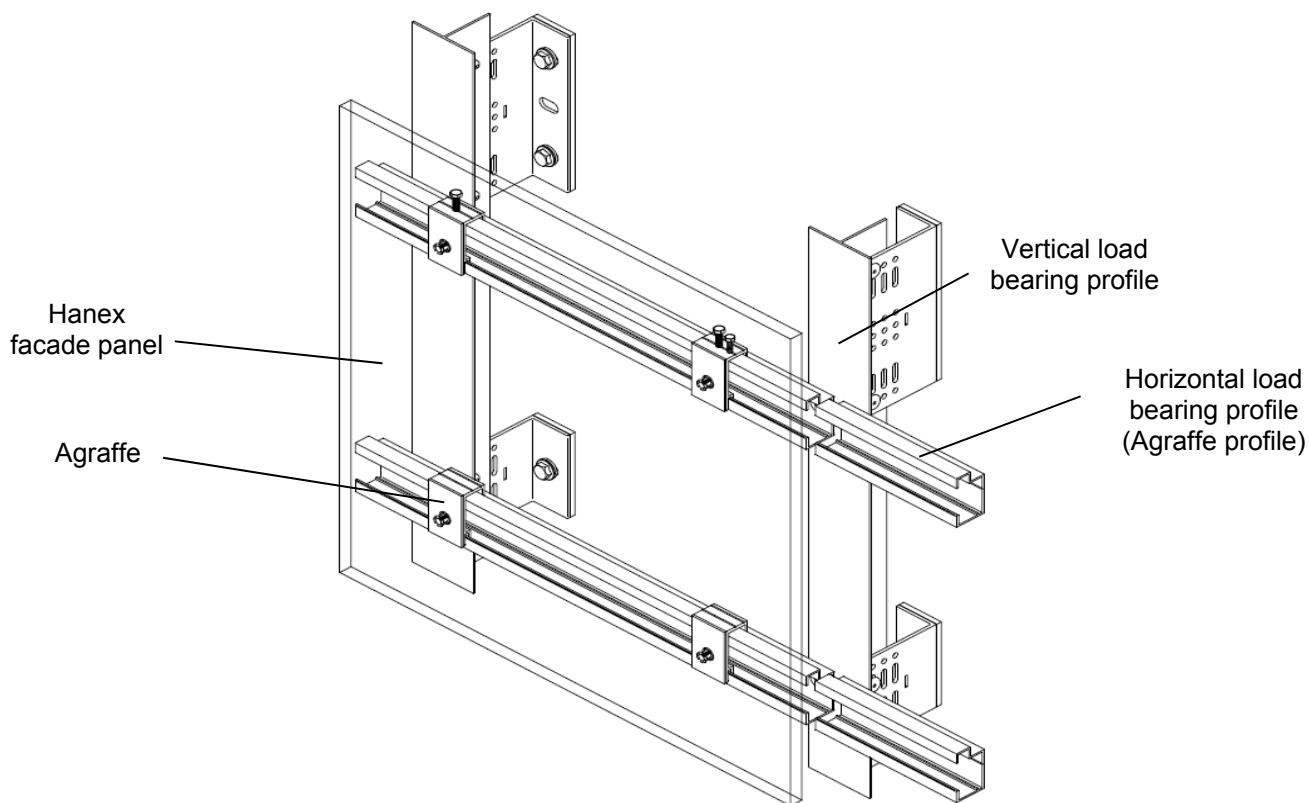

**Installed fastener
Keil KH 7,0**

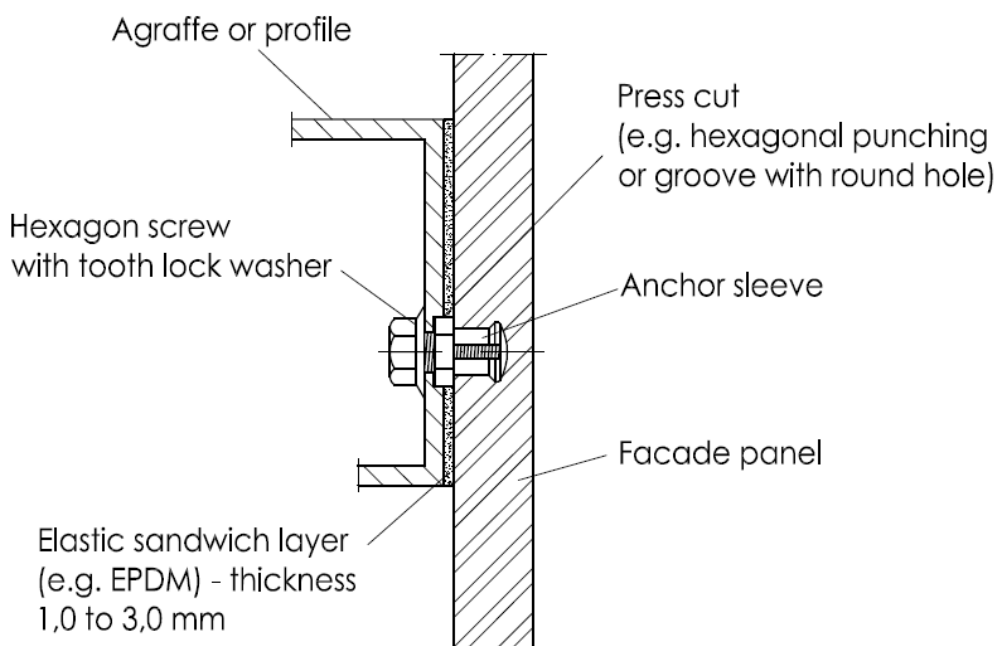

Hanex facade panel

Product description
Installed kit for external wall cladding and fixing

Annex A 1

Fastener for Hanex facade panel (KEIL KH 7,0 and Flat-head screw with coiled washer)

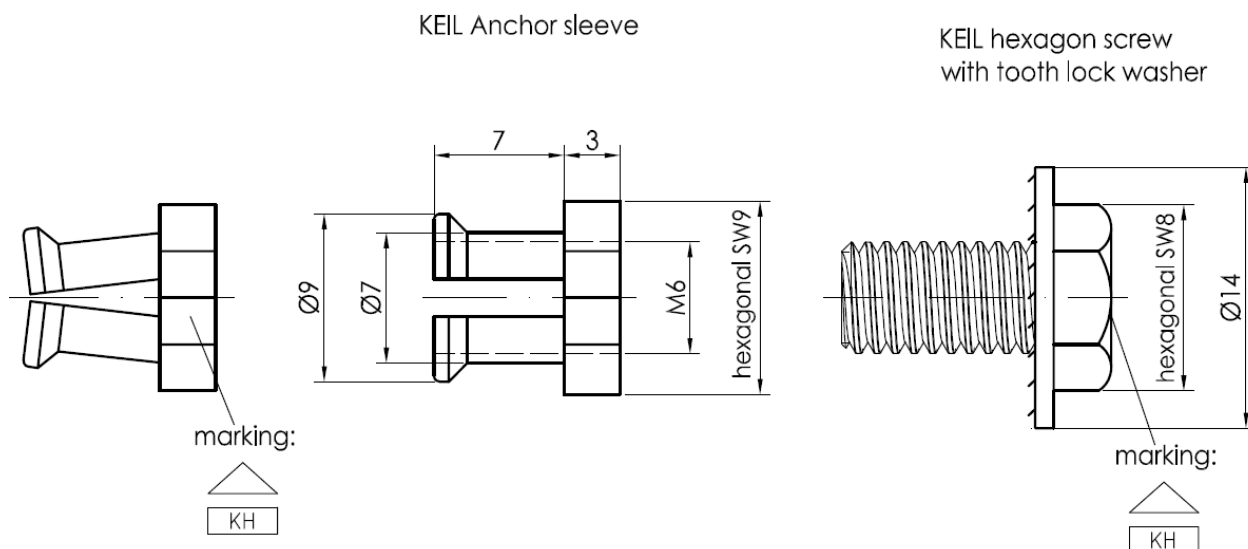

Hanex Facade panel (dimension in mm)

Table A2: Dimensions, materials and physical properties

Hanex Facade panel type			Hanex Solid Surfaces
thickness	t =	[mm]	12*
lengths	l =	[mm]	3680*
width	w =	[mm]	760*
colour identification			S-008 N-White
bulk density	ρ =	[KN/m ³]	18
thermal coefficient ³⁾	α _T =	[1/K]	30,4 x 10 ⁻⁶
Mean value of modulus of elasticity	E _{mean} ≥	[N/mm ²]	9500
bending resistance (acc. EN ISO 178:2013-09)	σ _{u5%} ¹⁾ ≥	[N/mm ²]	62
bending resistance (acc. EN ISO 178:2013-09)	σ _{B,min} ²⁾ =	[N/mm ²]	60
* width and lengths tolerances +0,5 mm; thickness tolerances ± 0,3 mm			
1) 5%-Quantil by a confidence level of 75 % and unknown standard deviation			
2) the minimum single value of the façade panel			
3) According to the information of the manufacture			

Hanex facade panel

Product description
Hanex Façade panel - dimensions, materials and physical properties

Annex A 2

Cladding fixings:

Fastener (dimension in mm)

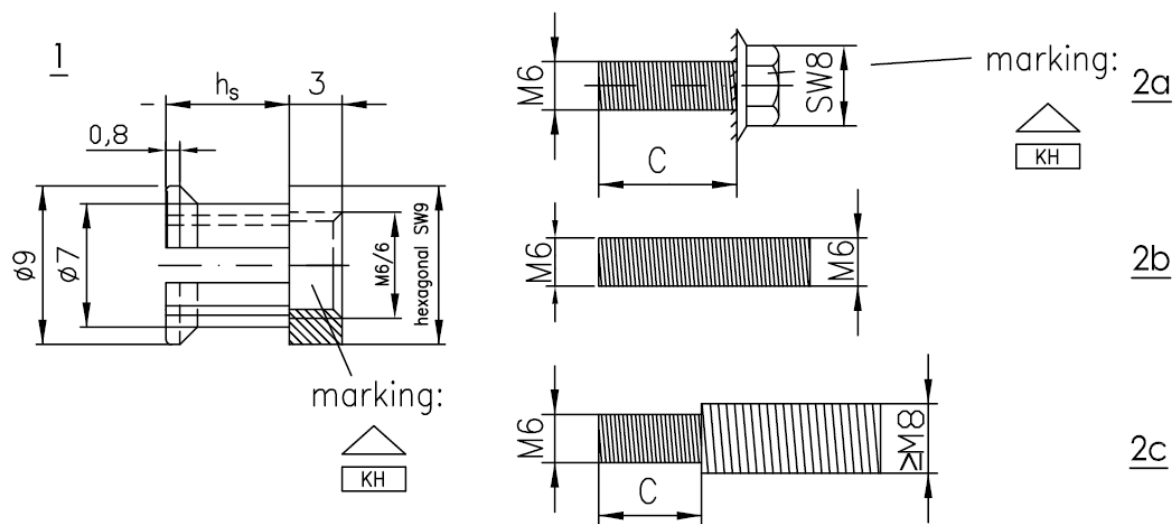

c: The screw must be adjusted to the respective design

Table A3: Dimensions and Materials

Fastener type		KEIL KH 7,0
embedment depth	$h_s =$ [mm]	7,0
screw length	$c =$ [mm]	$h_s + 3\text{mm} + t_{fix}$
installation torque moment	T_{inst} [Nm]	$2,5 \leq T_{inst} \leq 4,0$
Materials		
1	anchor sleeve	Stainless steel 1.4404 according to EN 10088:2014
2a	hexagon screw with tooth lock washer	stainless steel 1.4401, 1.4404 or 1.4578 according to EN 10088:2014
2b	threaded pin	
2c	threaded bolt	

Hanex facade panel

Product description
KEIL KH 7,0 - dimensions and materials

Annex A 3

Specifications of intended use

Scope

Accordinging the EAD 090062-00-0404 / Cladding family B

Anchorage subject to:

Static and quasi-static loads

Design

The design of the external wall claddings for ventilated façades using Hanex Façade kit comprising "Hanex façade panels" and the associated fixings should take into account:

- It is assumed that the substrate wall meets the necessary requirements regarding the mechanical strength (resistance to static and dynamic loads) and the airtightness, as well as the relevant resistance regarding watertightness and water vapour.
- The verification of the designed system by means of calculation, taking into account the mechanical characteristic values of the kit components in order to resist the actions (dead loads, wind loads, etc.) applying on the specific works. National safety factors and other national provisions must be followed.
- The design of the façade panels and their fixing can be carried out according to the conditions given in Annex B 2 to Annex B 4, the national regulations must be considered.
- The selection and verification of the brackets which support the subframe vertical profiles considering compatible materials (e.g. aluminium alloy) and the mechanical resistance (vertical and horizontal resistance) according to the envisaged actions obtained from the mechanical calculation of the designed system. Bracket resistance should be verified according to assessment given in EAD 090062-00-0404.
- The selection and verification of the anchors between the brackets and the external walls (substrate), taking into account the substrate material and the minimum resistance required (pull-out and shear resistance) according to the envisaged actions obtained from the mechanical calculation of the designed system.
- The accommodation of the designed system movements to the substrate or structural movements.
- The execution of singular parts of the façade; some examples of construction details are indicated in Annex A1.
- The corrosion protection of the designed system metallic components taking into account the category of corrosivity of the atmosphere of works (e.g. acc. ISO 9223).
- The drainability of the ventilated air space between the cladding elements and the insulation layer or the external wall accordingly.
- An insulation layer is usually fixed on the external wall and should be defined in accordance with a harmonized standard or an European technical assessment and taking into account the section 3.1 of this ETA.
- Because the joints are not watertight, the first layer behind ventilated air space (e.g. insulation layer) should be composed by materials with low water absorption.
- For the classification of the reaction to fire for the façade panel in end use conditions the following application parameters must be considered:

Panel colour S-008 N-White; panel thickness 12mm; bulk density approx. 1750 kg/m³; rear-ventilated outside wall claddings with air gap ≥ 20mm, mechanical fixed on bar shaped subframe of wood or metal, substrate with class A1 or A2-s1-d0 acc. EN 13501-1 (d≥20mm, ρ=35kg/m³), open joints ≤ 12mm, closed joints must be covered with metallic profiles

Hanex facade panel

Intended use

Specifications – scope and design

Annex B 1

Installation of the kits in works

Installation should be carried out according to the ETA holder’s specifications and using the specific kit components.

Installation should be carried out by appropriately qualified staff and under the supervision of the technical responsible of the site.

- The drillings are done at the factory or on site under workshop conditions; when making the drillings on site the execution is supervised by the responsible project supervisor or a skilled representative of the project supervisor.
- Making of the undercut drilling is done with the drill bit according to Annex B 6 and a special drilling device in accordance with the information deposited with Deutsches Institut für Bautechnik.
- The drillings are removed from the drill hole.
- In case of aborted hole: new drilling at a minimum distance away of twice the depth of the aborted hole.
- The geometry of the drill hole is checked on 1 % of all drillings. The following dimensions shall be checked and documented according to manufacturer's information and testing instructions by means of a measuring device according to Annex B 6:
 - Volume of the undercut drill hole.
 - Depth position of the undercut; the distance between the lower edge of the measuring device and the façade panel is between 0,0 and 0,3 mm (see Annex B 6).

If the tolerances are exceeded, the geometry of the drill hole shall be checked on 25% of the drillings performed. No further drill hole may exceed the tolerances otherwise all the drill holes shall be controlled. Drilling holes falling below or exceeding the tolerances shall be rejected.

Note: Checking the geometry of the drill hole on 1 % of all drillings means that on one of the 25 panels (this corresponds to 100 drillings in façade panels with four anchors) one drilling shall be checked. If the tolerances given in Annex A 3, Table A3 are exceeded the extent of the control shall be increase to 25 % of the drillings, i.e. one drilling each shall be checked on all the 25 panels.

- During transport and storage on site the façade panels are protected from damages; the façade panels are not be hung up jerkily (if need be lifters shall be used for hanging up the façade panels); façade panels and reveal panels respectively with incipient cracks are not be installed.
- The façade are installed by skilled specialists and the laying instructions of the manufacturer shall be paid attention to.
- The façade panels are arranged in a "reclined" or "upright" position, they also may be fixed at façade soffits.
- The profiles or agraffes must be fixed as defined and set out in this document (see Annex A/B).

Use, maintenance and repair of the works

Maintenance of the assembled systems or kits components includes inspections on site, taking into account the following aspects:

- regarding the Hanex façade panel: appearance of any damage such as cracking or detachment
- regarding the fasteners (fixing): presence of corrosion or deformation

Necessary repairs should be done rapidly, using the same kit components and following the repair instructions given by ETA holder.

Hanex facade panel

Intended use
Specifications – installation and use

Annex B 2

Design method

General

The design values of the actions shall be calculated on basis of EN 1990 in consideration of the existing loads. The combinations of actions shall be equal to EN 1990. The actions shall be specified according to EN 1991-1-1 to EN 1991-1-7. Corresponding national regulations shall be taken into consideration. The unfavourable combination is decisive. Where necessary for the design of the anchor and the façade panel several combinations shall be analysed separately.

The typical fundamental combination for façade panels considers actions from dead load $F_{Ek,G}$ (permanent action) and wind $F_{Ek,w}$ (leading variable action).

According to EN 1990 the following fundamental combination depending on the load direction results for a vertical façade panel:

Fundamental combination for loads parallel to the panel: $F_{Ed||} = F_{Ek,G} \cdot \gamma_G$

Fundamental combination for loads perpendicular to the panel: $F_{Ed\perp} = F_{Ek,w} \cdot \gamma_Q$
with $\gamma_G = 1,35$; $\gamma_Q = 1,50$

For hanging panels (over head mounting) or reveals respectively the load direction shall be taken into consideration and the combinations of actions shall be based on EN 1990.

The calculation shall be carried out in a linear elastic manner. The stiffness of the substructure shall be considered for the respective case of application.

- Each façade panel is fixed with at least four anchors in a rectangular arrangement via single agraffes or double agraffes on the substructure (for small panels or small fitted pieces, differential or fill- in pieces the number and position of the anchors shall be chosen constructively).
- The substructure is constructed such that the façade panels are fixed technically strain-free via skids (loose bearings) and one fixed point (fixed bearing) - the fixed point may be placed at the panel edge or in the panel field.
- Two fixing points of the façade panel are designed such that they are able to carry the dead load of the façade panel.
- When using agraffes on horizontal load-bearing profiles the fixing points of a façade panel situated horizontally at the same height are fastened in each case to the same load-bearing profile.
- Joint construction between the façade panels is done by a joint filler or are kept open; it is ensured that additional stresses (e.g. by temperature) do not lead to important additional loadings (see also classification of the reaction to fire for the façade panel in Annex B1).
- Verifiable calculation notes and drawings shall be prepared taking account of the loads to be anchored, the nature and strength of the base materials and the dimensions of the anchorage members as well as of the relevant tolerances. The position of the anchor is indicated on the design drawings.
- The façade panels, their fixings as well as the substructure including its connection to wall brackets and their connection to the construction works are designed for the respective case of application under the responsibility of an engineer skilled in the field of façade construction.

Hanex facade panel

Intended use

Specifications – installation and use

Annex B 3

Verification of the anchor loads

In addition to the actions from dead load and wind load the following actions shall be considered as permanent loads in direction to the anchor axes:

- in case of flush fixing of the anchor and when using horizontal load-bearing profiles: due to torsion of the load-bearing profile resulting from dead load of the façade panel the following load $N_{E_{k,V}}$ shall be considered:

$$N_{V,E_{k,V}} = V_{E_{k,V}} \cdot e/z$$

with $V_{E_{k,V}}$ = shear load due to dead load of the façade panel; e and z [mm] (see Figure 2)

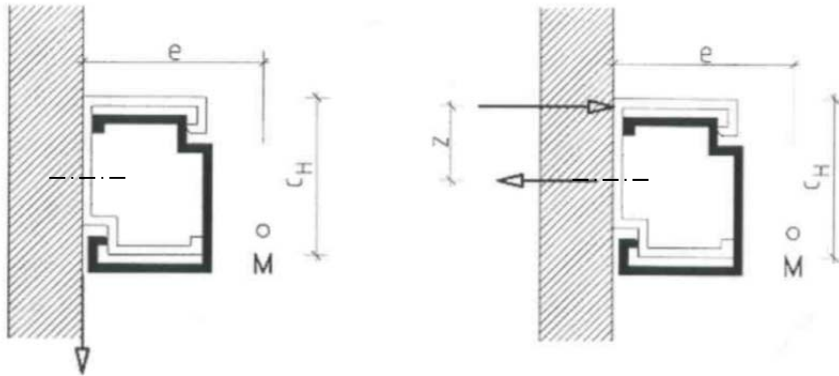

Figure 2: torsion of horizontal load-bearing profiles resulting from dead load of the façade panels

For the determined anchor forces it shall be verified that the following equation are met:

Equation 1: $\frac{\Sigma N_{Ed}}{N_{Rd}} \leq 1$

Equation 2: $\frac{V_{Ed}}{V_{Rd}} \leq 1$

Equation 3: $\frac{\Sigma N_{Ed}}{N_{Rd}} + \frac{V_{Ed}}{V_{Rd}} \leq 1,2$

With:

ΣN_{Ed} = design value of existing anchor tension load

$$\Sigma N_{Ed} = N_{Ed} + N_{V,Ed}$$

V_{Ed} = design value of existing anchor shear load

N_{Rd} = design value of anchor load-bearing capacity for tension load: $N_{Rd} = N_{Rk} / \gamma_M$ (with N_{Rk} and γ_M according to Annex C 1)

V_{Rd} = design value of anchor load-bearing capacity for shear load: $V_{Rd} = V_{Rk} / \gamma_M$ (with V_{Rk} and γ_M according to Annex C 1)

Verification of the bending stresses

For the determined bending stresses it shall be verified, that the following equation is met:

Equation 4: $\sigma_{Ed} \leq \sigma_{Rd}$

With

σ_{Ed} = design value of existing bending stress in the façade panel

σ_{Rd} = design value of bending strength: $\sigma_{Rd} = \sigma_{Rk} / \gamma_M$ with σ_{Rk} ; γ_M according to Annex C 1, Table C1

Electronic copy of the ETA by DIBt: ETA-18/0390

Hanex facade panel	Annex B 4
Intended use Specifications – installation and use	

English translation prepared by DIBt

Definition of edge distance and spacing

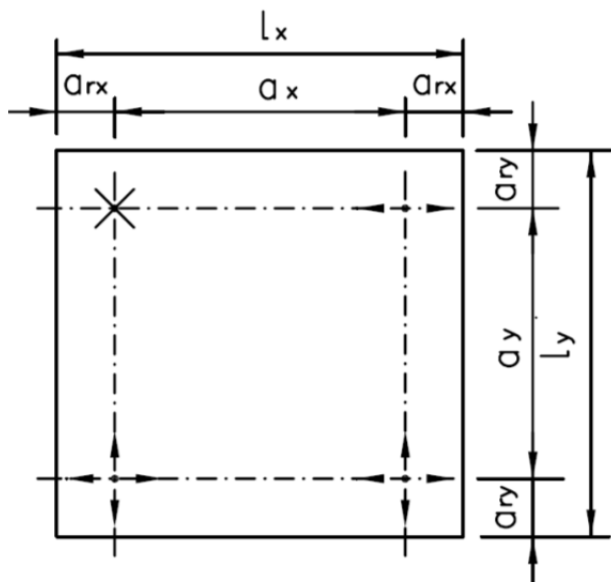

Legend:

- $a_{x,y}$ = edge distance – distance of an anchor to the panel edge
- $a_{x,y}$ = spacing – distance between anchors
- L_x = greater length of the façade panel
- L_y = smaller length of the façade panel
- X = fixed point (fixed bearing)
- ↔ = horizontal skid (loose bearing)
- ↕ = horizontal and vertical skid (loose bearing)

Example for fixed point and loose bearing

fixed bearing (fixed point)

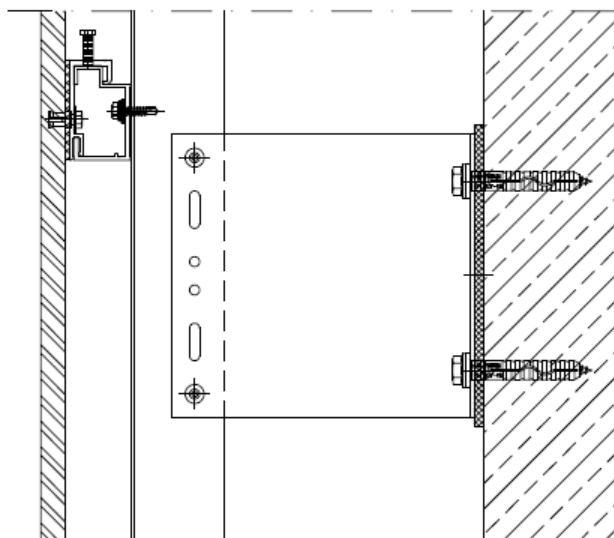

loose bearing (skid)

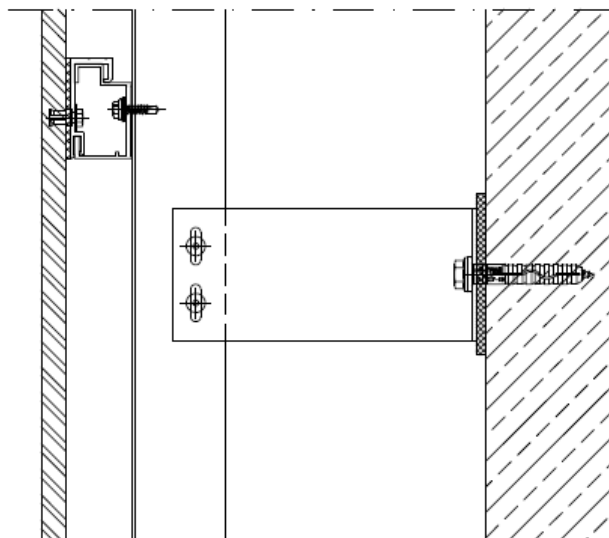

Hanex facade panel

Intended use
Specifications – installation and use

Annex B 5

Geometry of the KEIL facade drill for KEIL facade drill bit 7/9

Carbide tipped facade drill bit

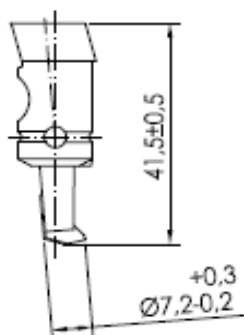

Carbide tipped drill bit / CNC

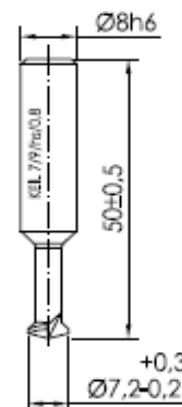

Geometry of the drill hole

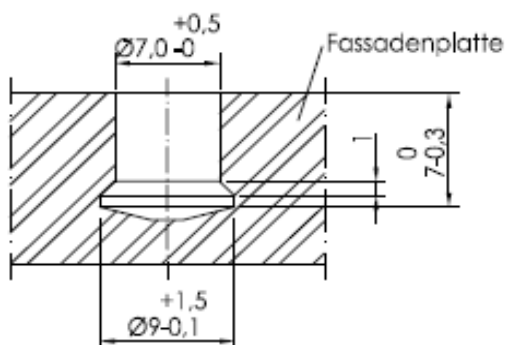

KEIL measuring device

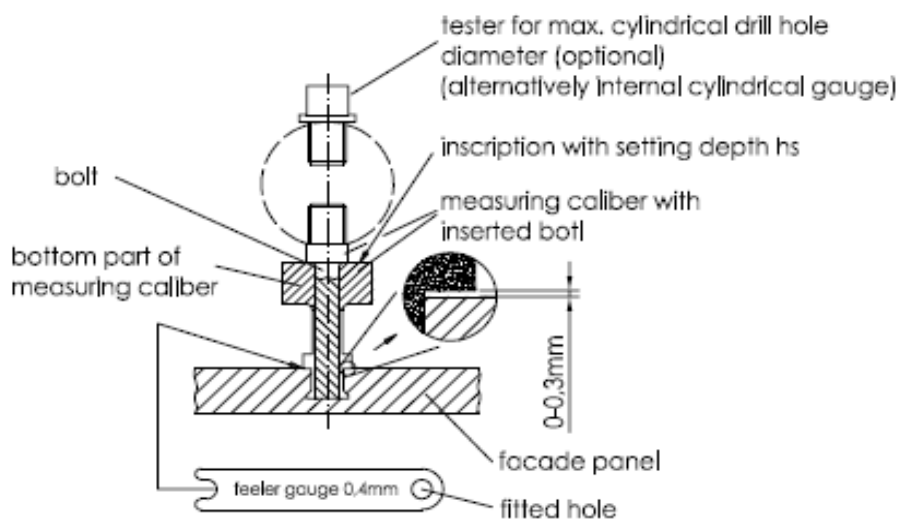

Drawing scale not true to real scale

Hanex facade panel

Intended use
Drill hole dimensions
Setting tools and testing equipment

Annex B 6

Installation instructions fastener

1. Drilling the undercut hole

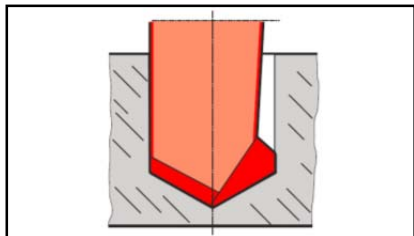

a) Cylindrical drilling

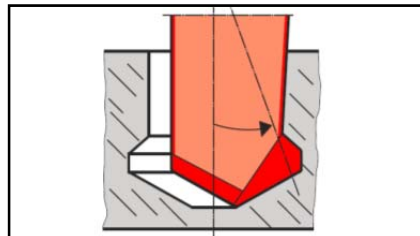

b) Undercutting and clearing

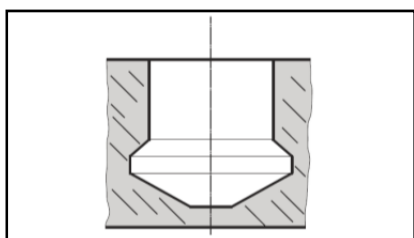

c) Finished undercut hole

2. Checking the undercut hole

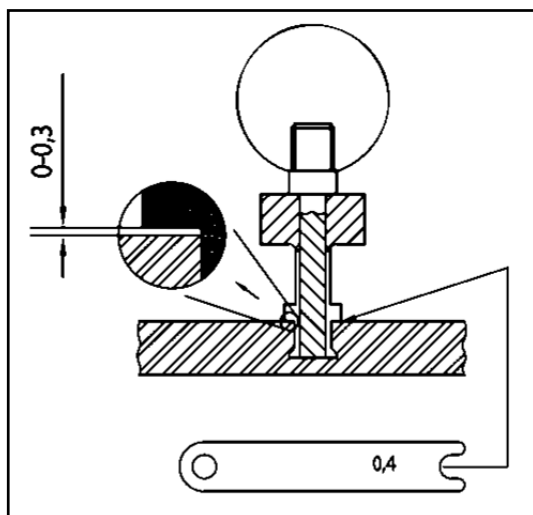

with KEIL depth control guide

Hanex facade panel

Intended use
Installation instructions fastener

Annex B 7

3. Installation of fastener (sleeve and screw)

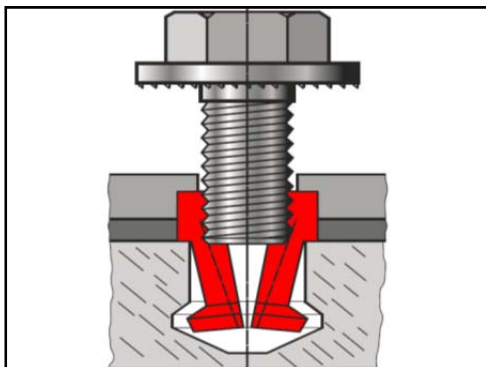

a) Insert the sleeve in the undercut hole and drill the screw in the sleeve

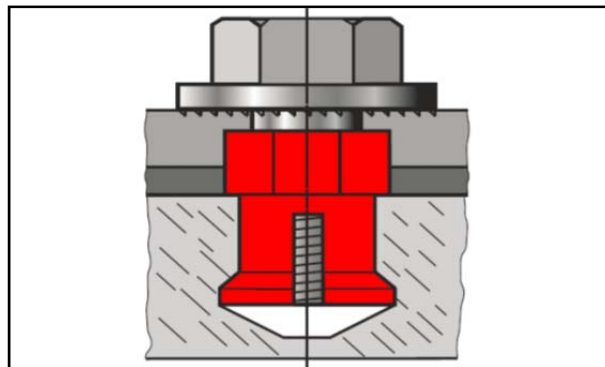

b) Installed undercut anchor

4. Installation of fastener (sleeve and grub screw)

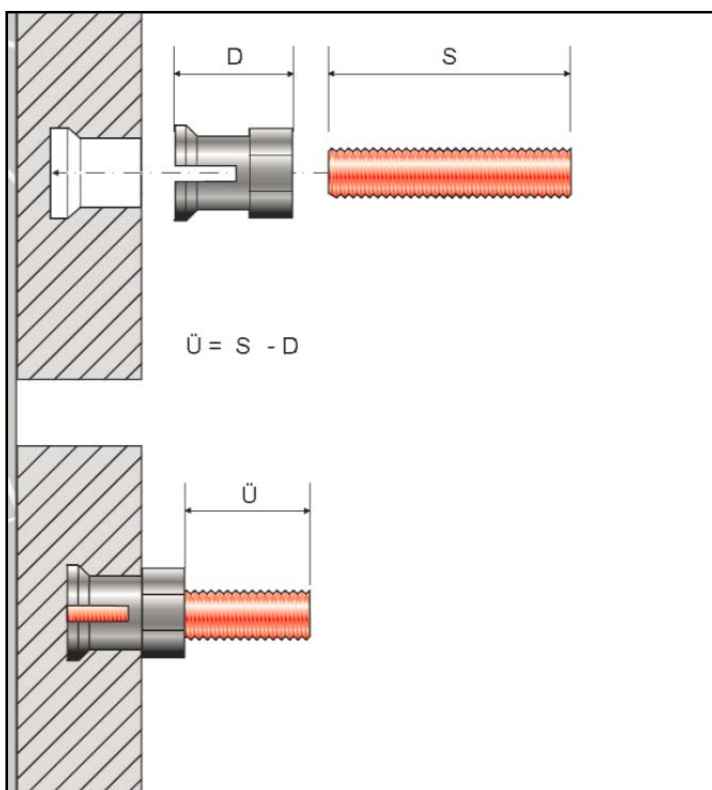

a) Insert the sleeve in the undercut hole

b) Drill the grub screw in the sleeve

c) Installed undercut anchor

Hanex facade panel

Performances
Characteristic values of the anchor and Hanex façade panel

Annex B 8

Table C1: Characteristic values and performances of the anchor and Hanex façade panel

characteristic values of Hanex façade panel	panel thickness	$h \geq$	[mm]	12,0		
	char. resistance to bending stress	$\sigma_{Rk} =$	[N/mm ²]	46,0		
	Mean value of modulus of elasticity	$E_{mean} =$	[N/mm ²]	9000		
	thermal coefficient	$\alpha_T =$	[1/K]	$30,4 \times 10^{-6}$		
	dead load	$g_k =$	[kN/m ²]	0,23		
	partial safety factor ¹⁾	$\gamma_M =$	[-]	1,8		
characteristic values of KEIL KH 7,0 anchor	anchorage depth	$h_s =$	[mm]	7		
	characteristic resistance to	tension load ²⁾	$N_{Rk} =$	[kN]	2,20	2,20
		shear load ²⁾	$V_{Rk} =$		3,00	3,30
	edge distance ³⁾	$a_r \geq$	[mm]	50	100	
	spacing	$a \geq$	[mm]	100		
	double agraffe	$a_D \geq$	[mm]	45		
	partial safety factor ¹⁾	$\gamma_M =$	[-]	1,8		

¹⁾ In absence of other national regulations.

²⁾ in case of coincident stress of an anchor due to tension and shear load the equation according to Annex B 4 shall be observed

³⁾ For small fitted pieces, differential and fill-in pieces the edge distance and spacing shall be chosen constructively

Aspects of durability and serviceability

Characteristic values and performances of the anchor and Hanex façade panel

characteristic values	Behaviour after pulsating load	[kN]	2,65
	Behaviour after Immersion in water	[kN]	2,74
	Freeze-thaw resistance	[kN]	2,32

Hanex facade panel

Performances

Characteristic values of the anchor and Hanex façade panel

Annex C 1