

Approval body for construction products
and types of construction

Bautechnisches Prüfamt

An institution established by the Federal and
Laender Governments



European Technical Assessment

ETA-19/0438
of 27 November 2019

English translation prepared by DIBt - Original version in German language

General Part

Technical Assessment Body issuing the
European Technical Assessment:

Deutsches Institut für Bautechnik

Trade name of the construction product

HALFEN Hot-rolled mounting channel HM;
Special screws HS

Product family
to which the construction product belongs

Hot-rolled mounting channel

Manufacturer

Halfen GmbH
Liebigstraße 14
40764 Langenfeld
DEUTSCHLAND

Manufacturing plant

HALFEN GmbH
Liebigstraße 14
40764 Langenfeld
DEUTSCHLAND

This European Technical Assessment
contains

18 pages including 14 annexes which form an integral
part of this assessment

This European Technical Assessment is
issued in accordance with Regulation (EU)
No 305/2011, on the basis of

EAD 330667-00-0602

The European Technical Assessment is issued by the Technical Assessment Body in its official language. Translations of this European Technical Assessment in other languages shall fully correspond to the original issued document and shall be identified as such.

Communication of this European Technical Assessment, including transmission by electronic means, shall be in full. However, partial reproduction may only be made with the written consent of the issuing Technical Assessment Body. Any partial reproduction shall be identified as such.

This European Technical Assessment may be withdrawn by the issuing Technical Assessment Body, in particular pursuant to information by the Commission in accordance with Article 25(3) of Regulation (EU) No 305/2011.

Specific part

1 Technical description of the product

The Halfen hot-rolled mounting channel HM is a system consisting of a C-shaped channel profile of carbon steel and stainless steel as well as a special shaped (hooked) Halfen-channel bolts.

The mounting channel can be welded to the steel structure. Any fixture may be connected to the mounting channel by Halfen-channel bolts with appropriate nuts and washers.

Figure 1 shows the principal setup of the construction product.

The product description is given in Annex A.

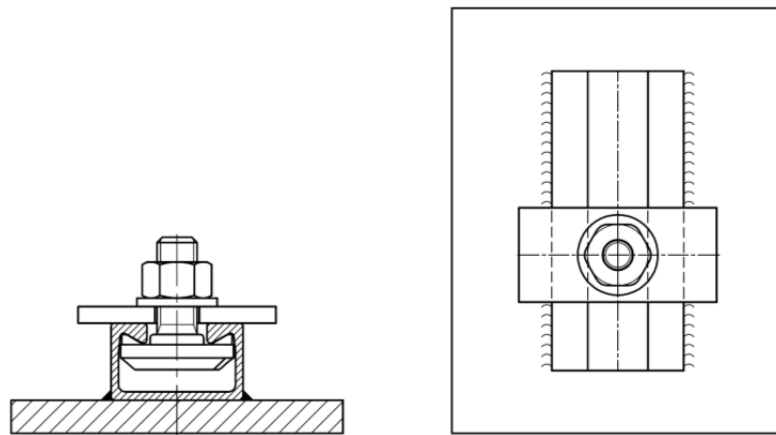

Figure 1: Principle setup of hot-rolled mounting channel

2 Specification of the intended use in accordance with the applicable European Assessment Document

The performances given in Section 3 are only valid if the mounting channel is used in compliance with the specifications and conditions given in Annex B.

The verifications and assessment methods on which this European Technical Assessment is based lead to the assumption of a working life of the mounting channel of at least 50 years. The indications given on the working life cannot be interpreted as a guarantee given by the producer, but are to be regarded only as a means for choosing the right products in relation to the expected economically reasonable working life of the works.

3 Performance of the product and references to the methods used for its assessment

3.1 Mechanical resistance and stability (BWR 1)

Essential characteristic	Performance
Characteristic resistance for tension under static and quasi-static loading	See Annex C1 to C2
Characteristic resistance for shear under static and quasi-static loading	See Annex C3 to C4
Installation parameters	See Annex B1 to B5
Geometric values	See Annex A1, A3 and A4
Durability	See Annex A2
Characteristic resistance for fatigue tensile loading	NPD

3.2 Safety in case of fire (BWR 2)

Essential characteristic	Performance
Reaction to fire	Class A1 according to EN 13501-1

4 Assessment and verification of constancy of performance (AVCP) system applied, with reference to its legal base

In accordance with EAD No. 330667-00-0602, the applicable European legal act is: 1998/214/EC

The system to be applied is: 2+

5 Technical details necessary for the implementation of the AVCP system, as provided for in the applicable EAD

Technical details necessary for the implementation of the AVCP system are laid down in the control plan deposited with Deutsches Institut für Bautechnik.

Issued in Berlin on 27 November 2019 by Deutsches Institut für Bautechnik

BD Dipl.-Ing. Andreas Kummerow
Head of Department

beglaubigt:

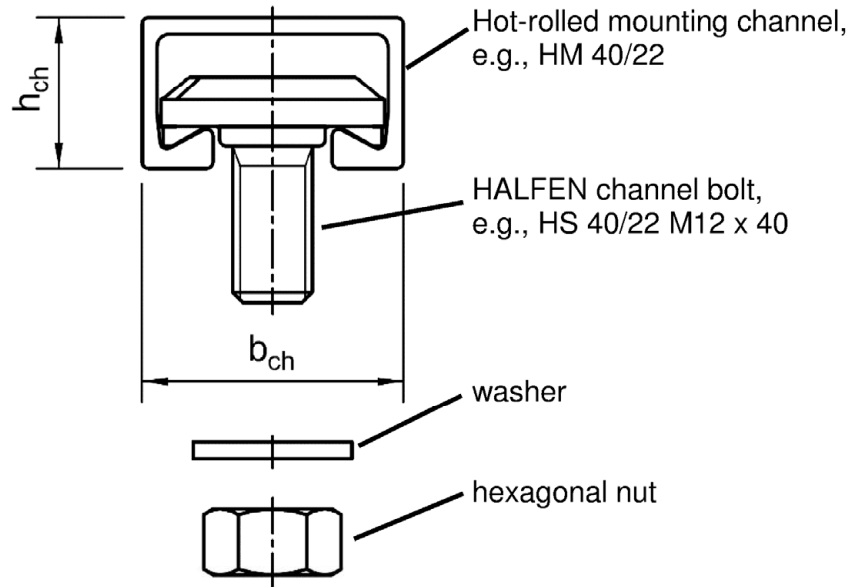

HALFEN hot-rolled mounting channels

HALFEN hot-rolled mounting channel	b _{ch} [mm]	h _{ch} [mm]
HM 40/22	39,50	23,00
HM 50/30	49,00	30,00
HM 52/34	52,50	33,50
HM 55/42	54,50	42,00
HM 72/48	72,00	48,50

Material of channels:

Steel

1.0038/1.0044

Stainless steel

A2 1.4301/1.4307/1.4541
A4 1.4401/1.4404/1.4571
L4, DX 1.4362
F4, FA 1.4462
HCR 1.4529/1.4547

Marking of the HALFEN channel bolts
e.g.: HALFEN A4-70

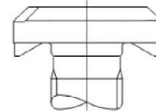

H or HALFEN

Identifying mark of the producer

A4

Material

70

Strength grade

Material of channel bolts:

Steel

No marking

Stainless steel

A2 1.4301/1.4307/1.4567/1.4541
A4 1.4401/1.4404/1.4571/1.4578
L4 1.4362
F4, FA 1.4462
HCR 1.4529/1.4547

Strength grade of the channel bolts:

Steel

4.6, 8.8 Strength grade 4.6, 8.8

Stainless steel

50, 70 Strength grade 50, 70

HALFEN Hot-Rolled Mounting Channels HM

Product description
Marking and materials

Annex A1

Table A2: Materials and intended use

Item no.	Specification	Intended use			
		1	2	3	4
		Dry internal conditions	Internal conditions with usual humidity	Medium corrosion exposure	High corrosion exposure
		Hot-Rolled Mounting Channels may only be used in structures subject to dry internal conditions. e.g. accomodations, bureaus, schools, hospitals, shops, exceptional internal conditions with usual humidity acc. column 2	Hot-Rolled Mounting Channels may also be used in structures subject to internal conditions with usual humidity. e.g. kitchen, bath and laundry in residential buildings, exceptional permanent damp conditions and application under water	Hot-Rolled Mounting Channels may also be used in structures subject to external atmospheric exposure (incl. industrial and marine environment) or exposure in permanently damp internal conditions, if no particular aggressive conditions exist. e.g. structures subject to external atmospheric exposure if no particular aggressive conditions exist acc. column 4	Hot-Rolled Mounting Channels may also be used in structures subject to exposure in particular aggressive conditions. e.g. permanent, alternating immersion in seawater or the splash zone of seawater, chloride atmosphere of indoor swimming pools or atmosphere with chemical pollution (e.g. in desulphurization plants or road tunnels where de-icing materials are used)
Materials					
①	HALFEN Hot-Rolled Mounting Channel	Steel 1.0038 (A), 1.0044 (A) hot-dip galv. $\geq 55 \mu\text{m}$ acc. to (J)	Steel 1.0038 (A), 1.0044 (A) hot-dip galv. $\geq 55 \mu\text{m}$ acc. to (J) Stainless Steel ⁴⁾ 1.4301 (B), 1.4307 (B), 1.4541 (B)	Stainless steel ⁴⁾ 1.4401 (B), 1.4404 (B), 1.4571 (B), 1.4362 (B)	Stainless steel ⁴⁾ 1.4462 ²⁾ (B), 1.4529 (B), 1.4547 (B)
②	HALFEN Channel Bolts	Steel strength grade 4.6 / 8.8 (C) electroplated $\geq 5 \mu\text{m}$ acc. to (G)	Steel strength grade 4.6 / 8.8 (C) hot-dip galv. $\geq 50 \mu\text{m}$ acc. to (H) ¹⁾ Stainless Steel ⁴⁾ strength grade 50, 70 (D) 1.4301 (B), 1.4307 (B), 1.4567 (B), 1.4541 (B)	Stainless steel ⁴⁾ strength grade 50, 70 (D) 1.4401 (B), 1.4404 (B), 1.4571 (B), 1.4362 (B), 1.4578 (B)	Stainless steel ⁴⁾ strength grade 50, 70 (D) 1.4462 ²⁾ (B), 1.4529 (B), 1.4547 (B)
③	Washer ³⁾ (I) and (K) production class A, 200 HV	Steel EN 10025 electroplated $\geq 5 \mu\text{m}$ acc. to (G)	Steel EN 10025 hot-dip galv. $\geq 50 \mu\text{m}$ acc. to (H) ¹⁾ Stainless Steel ⁴⁾ steel grade A2, A3 (D)	Stainless steel ⁴⁾ steel grade A4, A5 (D)	Stainless steel ⁴⁾ 1.4462 ²⁾ (B), 1.4529 (B), 1.4547 (B)
④	Hexagonal nuts (L)	Steel strength grade 5/8 (E) electroplated $\geq 5 \mu\text{m}$ acc. to (G)	Steel strength grade 5/8 (E) hot-dip galv. $\geq 50 \mu\text{m}$ acc. to (H) ¹⁾ Stainless steel ⁴⁾ strength grade 70, 80 (F) steel grade A2, A3 (F)	Stainless steel ⁴⁾ strength grade 70, 80 (F) steel grade A4, A5 (F)	Stainless steel ⁴⁾ strength grade 70, 80 (F) 1.4462 ²⁾ (B), 1.4529 (B), 1.4547 (B)

A - EN 10025-2:2004
B - EN 10088-3:2014
C - EN ISO 898-1:2013
D - EN ISO 3506-1:200

E - EN ISO 898-2:2012
F - EN ISO 3506-2:2009
G - EN ISO 4042:1999
H - EN ISO 10684:2004

I - EN ISO 7089:2000
J - EN ISO 1461:2009
K - EN ISO 7093-1:2000
L - EN ISO 4032:2012

¹⁾ or electroplated with special coating $\geq 12 \mu\text{m}$

²⁾ 1.4462 not applicable for indoor swimming pools

³⁾ not included in scope of delivery

⁴⁾ stainless steel channel profiles only in combination with stainless steel channel bolts, washers and nuts

HALFEN Hot-Rolled Mounting Channels HM

Product description
Materials and intended use

Annex A2

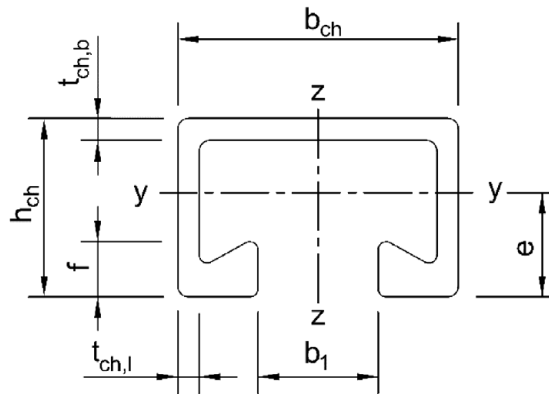

Table A3-1: Profile dimensions (steel and stainless steel)

Hot-rolled-mounting channel	Material	Dimensions					
		b_{ch} [mm]	h_{ch} [mm]	$t_{ch,b}$ [mm]	$t_{ch,l}$ [mm]	b_1 [mm]	f [mm]
40/22	steel	39,50	23,00	2,60	2,30	18,00	6,00
50/30		49,00	30,00	3,20	2,65	22,50	7,85
52/34		52,50	33,50	4,10	4,00	22,50	10,50
55/42		54,50	42,00	5,00	5,00	26,00	12,90
72/48		72,00	48,50	4,50	5,00	33,00	15,50
40/22	stainless steel	39,50	23,00	2,60	2,30	18,00	6,00
50/30		49,00	30,00	3,20	2,65	22,50	7,85
52/34		52,50	33,50	4,10	4,00	22,50	10,50
72/48		72,00	48,50	4,50	5,00	33,00	15,50

Table A3-2: Cross-section values of profiles (steel and stainless steel)

Hot-rolled-mounting channel	Material	Cross-section values						
		e [mm]	I_y [mm ⁴]	I_z [mm ⁴]	$W_{el,y}$ [mm ³]	$W_{el,z}$ [mm ³]	$W_{pl,y}$ [mm ³]	$W_{pl,z}$ [mm ³]
40/22	steel	12,46	19859	57718	1594	2922	2169	3681
50/30		16,29	52575	137809	3228	5625	4383	7051
52/34		17,42	93336	237412	5357	9044	7186	11502
55/42		22,10	187482	362909	8485	13318	11727	16687
72/48		24,01	349723	833480	14279	23152	18283	28943
40/22	stainless steel	12,46	19859	57718	1594	2922	2169	3681
50/30		16,29	52575	137809	3228	5625	4383	7051
52/34		17,42	93336	237412	5357	9044	7186	11502
72/48		24,01	349723	833480	14279	23152	18283	28943

HALFEN Hot-Rolled Mounting Channels HM

Product description
Profile dimensions

Annex A3

HALFEN channel bolt, Hook-head geometry

Notch for
marking the
position

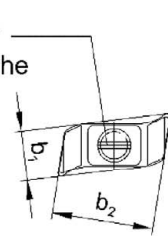

Marking acc Annex A1

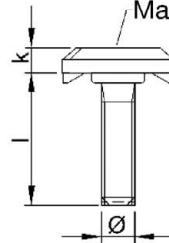

alternative Hook-head geometry

Notch for
marking the
position

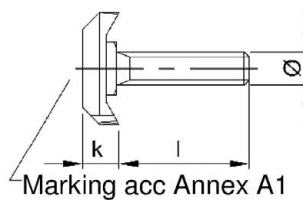
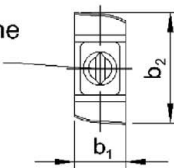

Marking acc Annex A1

Table A4: Dimensions of HALFEN channel bolts

Head	HS	Thread Ø	Channel bolts - wing shape			Channel bolts - alternative shape			Hot-rolled mounting channel
			Width b ₁ [mm]	Length b ₂ [mm]	Thickness k [mm]	Width b ₁ [mm]	Length b ₂ [mm]	Thickness k [mm]	
Hook-head	40/22	M10	15	30,8	7,2	–	–	–	40/22
		M12	15	30,8	7,2	–	–	–	
		M16	17,4	30,8	8,2 (9,8)	–	–	–	
	50/30	M10	16,3	40,2	10	15	41,5	10	50/30
		M12	16,3	40,2	10	15	41,5	10	52/34
		M16	19,4	40,2	11	20	41,5	11	55/42
		M20	21	39,5	12,5	21	41,5	12	
		M24	–	–	–	24,5	41	18	55/42
	72/48	M20	–	–	–	23	58	14	72/48
		M24	–	–	–	25	58	16	
M27		–	–	–	28	58	18		
M30		–	–	–	31	58	20		

() value applies for strength grade 8.8

HALFEN Hot-Rolled Mounting Channels HM

Product description
HALFEN channel bolts, dimensions

Annex A4

Table A5: Strength grade of HALFEN channel bolts

	Steel ¹⁾		Stainless steel ¹⁾	
Strength grade	4.6	8.8	50	70
f _{uk} [N/mm ²]	400	800	500	700
f _{yk} [N/mm ²]	240	640	210	450
Finish	electroplated, hot-dip galv.		–	

¹⁾ materials according Annex A1 and Annex A2, Tab. A2

HALFEN Hot-Rolled Mounting Channels HM

Product description
HALFEN channel bolts, strength grade

Annex A5

Specifications for intended use

HALFEN hot-rolled mounting channels and channel bolts subject to:

- Static and quasi-static loads in tension and shear perpendicular to the longitudinal axis of the channel and combinations of these loads.
- Shear loads with or without lever arm.

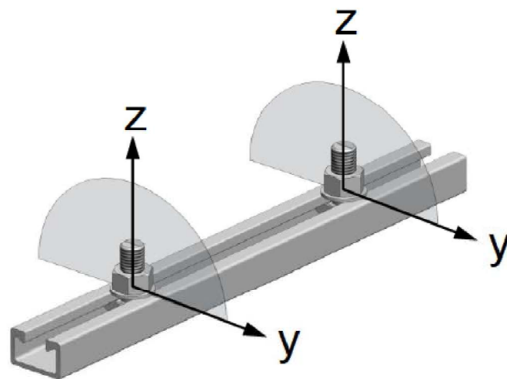

tension load: z-direction

shear load: y-direction

- HALFEN hot-rolled mounting channels can be connected to the structure by direct welding or by lugs welded to the channel walls.

Use conditions (Environmental conditions):

- Structures subject to dry internal conditions (e.g. accommodations, bureaus, schools, hospitals, shops, exceptional internal conditions with usual humidity)
(hot-rolled mounting channels and channel bolts according to Annex A2, Table A2, column 1 - 4)
- Structures subject to internal conditions with usual humidity (e.g. kitchen, bath and laundry in residential buildings, exceptional permanent damp conditions and application under water)
(hot-rolled mounting channels and channel bolts according to Annex A2, Table A2, column 2 - 4)
- Structures subject to external atmospheric exposure (incl. industrial and marine environment) or exposure to permanently damp internal conditions, if no particular aggressive conditions (e.g. permanent, alternating immersion in seawater etc.) exist.
(hot-rolled mounting channels and channel bolts according to Annex A2, Table A2, column 3 - 4)
- Structures subject to exposure in particular aggressive conditions (e.g. permanent, alternating immersion in seawater or the splash zone of seawater, chloride atmosphere of indoor swimming pools or atmosphere with chemical pollution (e.g. in desulphurization plants or road tunnels where de-icing materials are used))
(hot-rolled mounting channels and channel bolts according to Annex A2, Table A2, column 4)

Design:

- HALFEN hot-rolled mounting channels are designed under the responsibility of an engineer experienced in framing systems and bolted connections.
- For static and quasi-static loading the hot-rolled mounting channels are designed according to Annexes C1 – C4 and EN 1993-1-1.
- The welding seams are calculated in accordance to EN 1993-1-8. The spacing of the welding seams must not exceed the minimum spacing of the channel bolts given in Annex C1, Table C1-1 resp. Annex C3, Table C3-1 (max. $e_w \leq S_{\min,s,N}$).

HALFEN Hot-Rolled Mounting Channels HM

Intended use
Specifications

Annex B1

Installation:

- The installation of hot-rolled mounting channels is carried out by appropriately qualified personnel under the supervision of the person responsible for the technical matters on site.
- Use of HALFEN hot-rolled mounting channels only as supplied by the manufacturer without any alterations. Hot-rolled mounting channels and channel bolts are a complete system and must always be used as a set.
- For hot-rolled mounting channels made of stainless steel there are no restrictions regarding corrosion resistance when using cut channel pieces, if cutting is done professionally and contamination of cutting edges with corroding material is avoided.
- Installation in accordance with the installation instruction given in Annexes B4 and B5.
- Washers may be chosen according to Annex A2 and provided separately by the user.
- Orientating the channel bolt (groove mark according to Annex B4) rectangular to the channel axis.
- The required installation torque given in Annex B3 must be applied and must not be exceeded.

Transport and storage of hot-rolled mounting channels made of stainless steel:

- Hot-rolled mounting channels made of stainless steel must be stored separately from carbon steel and other metallic materials to avoid surface contamination.
- Store in a dry place.

HALFEN Hot-Rolled Mounting Channels HM

Intended use
Specifications

Annex B2

Table B3: Installation torque of HALFEN channel bolts

HALFEN hot-rolled mounting channel	HALFEN channel bolts \varnothing	Min. spacing $s_{\min, cbo}$ of channel bolts	Installation torque T_{inst} ²⁾			
			Steel – steel contact ¹⁾			
			Steel 4.6	Steel 8.8	Stainless steel 50	Stainless steel 70
	[mm]	[mm]	[Nm]			
40/22	10	50	15	40	15	30
	12	60	25	70	25	50
	16	80	65	180	60	130
50/30	10	50	15	40	15	30
	12	60	25	70	25	50
	16	80	65	180	60	130
	20	100	130	360	120	250
52/34	10	50	15	40	15	30
	12	60	25	70	25	50
	16	80	65	180	60	130
	20	100	130	360	120	250
55/42	10	50	15	40	15	30
	12	60	25	70	25	50
	16	80	65	180	60	130
	20	100	130	360	120	250
	24	120	230	620	200	440
72/48	20	100	130	360	120	250
	24	120	230	620	200	440
	27	135	340	900	300	650
	30	150	460	1200	400	850

¹⁾ materials according to Annex A1 and Annex A2, Tab. A2

²⁾ T_{inst} must not be exceeded

HALFEN Hot-Rolled Mounting Channels HM

Intended use
Installation parameters

Annex B3

Installation of hot-rolled mounting channels

- Hot-rolled mounting channel is cut to length and positioned. It can be advisable to set some weld spots for pre-fixation. Hot-rolled mounting channels made of carbon steel have to be welded before corrosion protection e.g. hot-dip galvanising.
- Welding may only be carried out by qualified personnel with suitable welding procedures.
- Steel components to which the hot-rolled mounting channels are welded must have sufficient weldability.
- If necessary, the quality of the weld seam shall be tested by suitable non-destructive testing.
- The welding seams are calculated in accordance to EN 1993-1-8. The spacing of the welding seams must not exceed the minimum spacing of the channel bolts given in Annex C1, Table C1-1 resp. Annex C3, Table C3-1 (max. $e_w \leq S_{\min,s,N}$).
- After the welding residues have been removed the entire structure (carbon steel) is protected against corrosion, e. g. by hot-dip galvanizing.

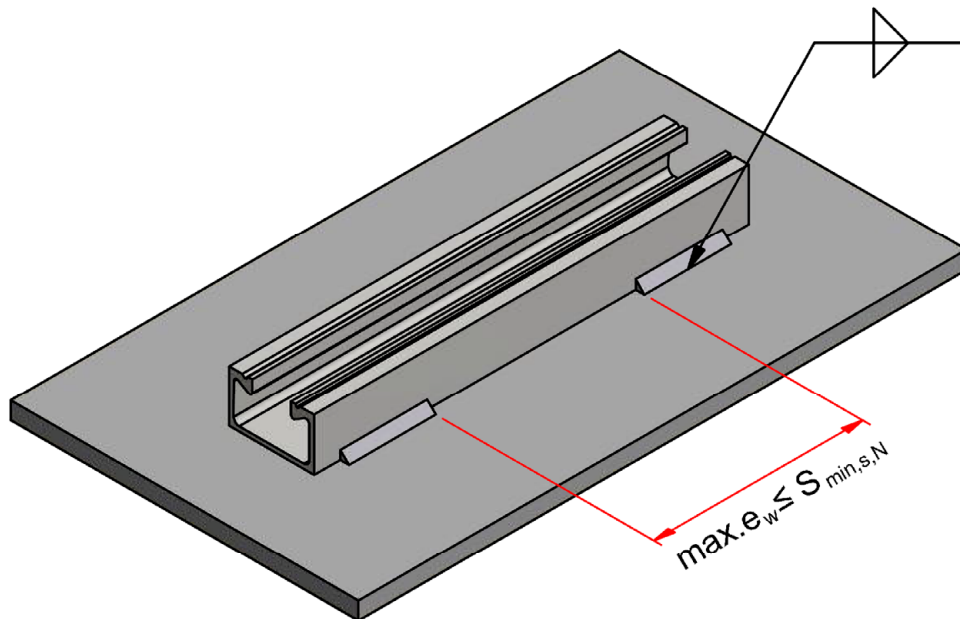

HALFEN Hot-Rolled Mounting Channels HM

Intended use
Installation instruction – HALFEN hot-rolled mounting channels

Annex B4

Installation of HALFEN channel bolts

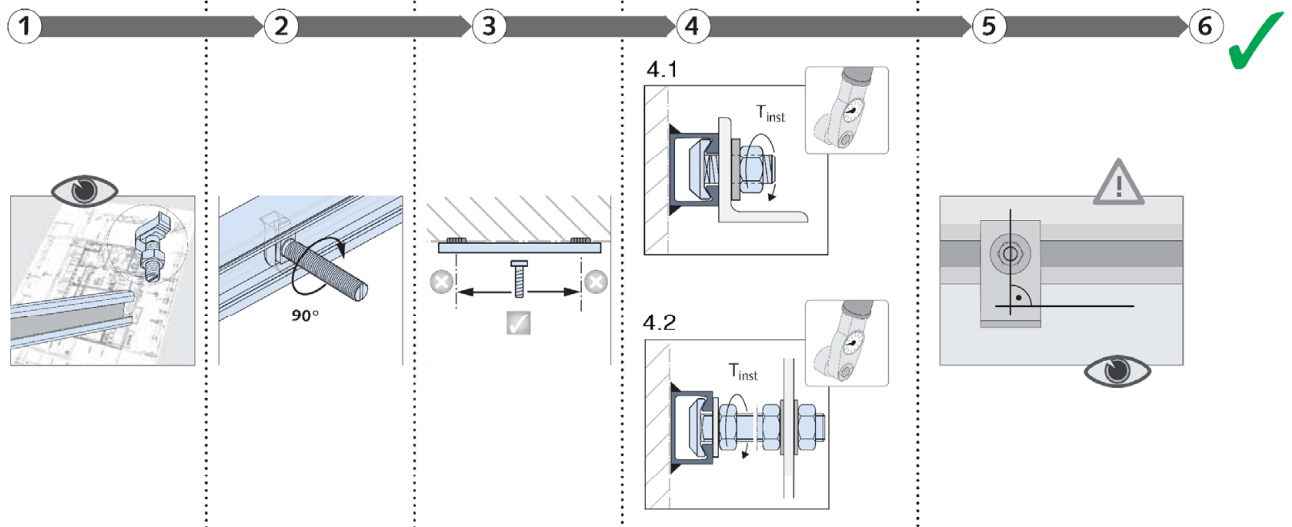

Selection of the HALFEN channel bolts in accordance with the planning document.

Insert the HALFEN channel bolts into the channel slot. After a 90° turn clockwise the HALFEN screw locks into position (check whether the groove mark is perpendicular to the channel longitudinal axis).

Positioning of the HALFEN channel bolts: The bolts must not be mounted outside the welding seams at the channel ends.

Tighten the hexagonal nut to the installation torque (T_{inst}) acc. table stated below. T_{inst} must not be exceeded. 4.1: general application, 4.2: installation with lever arm

After tightening the nut check if the groove mark on the HALFEN channel bolt is perpendicular to the channel longitudinal axis. If it is not perpendicular the screw must be completely loosened, re-inserted and tightened again.

Table B5: Installation torque of HALFEN channel bolts

Material/strength grade		Hot-rolled mounting channel	T_{inst} [Nm] ¹⁾						
			M10	M12	M16	M20	M24	M27	M30
Steel	4.6	All profiles	15	25	65	130	230	340	460
	8.8		40	70	180	360	620	900	1200
Stainless steel	50		15	25	60	120	200	300	400
	70		30	50	130	250	440	650	850

¹⁾ T_{inst} must not be exceeded

HALFEN Hot-Rolled Mounting Channels HM

Intended use
Installation instruction – HALFEN channel bolts

Annex B5

Table C1-1: Characteristic resistance for tension under static and quasi-static loading

Mounting channel ¹⁾			HM 40/22	HM 50/30	HM 52/34	HM 55/42	HM 72/48
Resistance for tension, local failure of channel lips							
Minimum spacing of bolts	$S_{\min, s, N}$	[mm]	150	200	200	250	300
Characteristic resistance	$N_{Rk, s, l}$	[kN]	26	38	68	100	120
Partial safety factor	$\gamma_{Ms, l}$ ²⁾		1,8				

¹⁾ for steel and stainless steel

²⁾ in absence of other national regulations

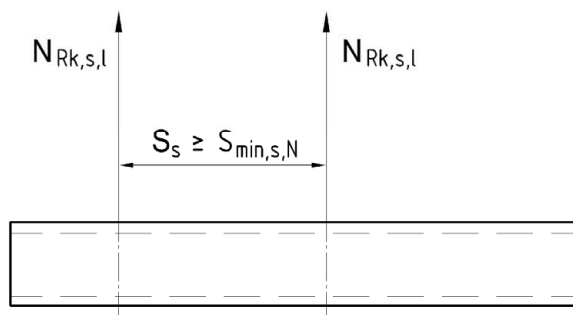

Table C1-2: Displacements under tension service load

Mounting channel ¹⁾			HM 40/22	HM 50/30	HM 52/34	HM 55/42	HM 72/48
Displacement due to tensile loading							
Service load	N	[kN]	10,4	15,2	27,2	40,0	48,0
Displacement	δ_N	[mm]	0,5	0,5	0,6	0,6	0,6

¹⁾ for steel and stainless steel

HALFEN Hot-Rolled Mounting Channels HM

Performances
Characteristic resistances under tension load – steel failure of channel and displacements

Annex C1

Table C2: Characteristic resistances under tension load – steel failure of HALFEN channel bolts

HALFEN channel bolts \emptyset	M10	M12	M16	M20	M24	M27	M30
Steel failure							
Charakt. resistance $N_{Rk,s}$ [kN]	4.6	33,7	62,8	98,0	141,2	183,6	224,4
	8.8	46,4	125,6	196,0	282,4	367,2	448,8
	50 ¹⁾	29,0	78,5	122,5	176,5	229,5	280,5
	70 ¹⁾	40,6	109,9	171,5	247,1	321,3	392,7
Partial safety factor γ_{Ms} ²⁾	4.6	2,00					
	8.8	1,50					
	50 ¹⁾	2,86					
	70 ¹⁾	1,87					

¹⁾ materials according Annex A1 and A2
²⁾ in absence of other national regulations

HALFEN Hot-Rolled Mounting Channels HM

Performances
Characteristic resistances under tension load – steel failure of channel bolts

Annex C2

Table C3-1: Characteristic resistance for shear under static and quasi-static loading

Mounting channel ¹⁾			HM 40/22	HM 50/30	HM 52/34	HM 55/42	HM 72/48
Resistance for shear, local failure of channel lips							
Minimum spacing of bolts	$S_{\min, s, v}$	[mm]	150	200	200	250	300
Characteristic resistance	$V_{Rk, s, l}$	[kN]	14	27	38	45	50
Partial safety factor	$\gamma_{Ms, l}$		1,8				

¹⁾ for steel and stainless steel

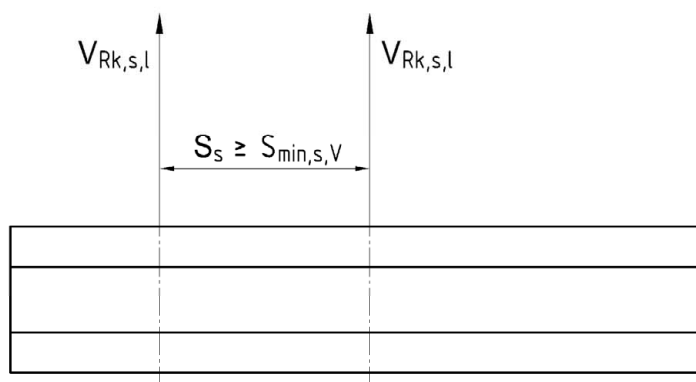

Table C3-2: Displacements under shear service load

Mounting channel ¹⁾			HM 40/22	HM 50/30	HM 52/34	HM 55/42	HM 72/48
Displacement due to shear loading							
Service load	V	[kN]	5,6	10,8	15,2	18,0	20,0
Displacement	δ_v	[mm]	0,3	0,8	0,6	0,6	0,9

¹⁾ for steel and stainless steel

HALFEN Hot-Rolled Mounting Channels HM

Performances
Characteristic resistances under shear load – steel failure of channel and displacements

Annex C3

Table C4: Characteristic resistances under shear load – steel failure of HALFEN channel bolts

HALFEN channel bolts Ø		M10	M12	M16	M20	M24	M27	M30
Steel failure								
Characteristic resistance	$V_{Rk,s}$ [kN]	4.6	20,2	37,7	58,8	84,7	110,2	134,6
		8.8	33,7	62,8	98,0	141,2	183,6	224,4
		50 ¹⁾	25,3	47,1	73,5	105,9	137,7	168,3
		70 ¹⁾	35,4	65,9	102,9	148,3	192,8	235,6
Characteristic flexure resistance	$M^0_{Rk,s}$ [Nm]	4.6	52,4	133,2	259,6	449,0	665,8	899,6
		8.8	104,8	266,4	519,3	898,0	1331,5	1799,2
		50 ¹⁾	65,5	166,5	324,5	561,3	832,2	1124,5
		70 ¹⁾	91,7	233,1	454,4	785,8	1165,1	1574,3
Partial safety factor	$\gamma_{Ms}^{2)}$	4.6	1,67					
		8.8	1,25					
		50 ¹⁾	2,38					
		70 ¹⁾	1,56					

¹⁾ materials according Annex A1 and A2
²⁾ in absence of other national regulations

HALFEN Hot-Rolled Mounting Channels HM

Performances
Characteristic resistances under shear load – steel failure of channel bolts

Annex C4