

Approval body for construction products  
and types of construction

Bautechnisches Prüfamt

An institution established by the Federal and  
Laender Governments



## European Technical Assessment

ETA-19/0460  
of 15 August 2019

English translation prepared by DIBt - Original version in German language

### General Part

Technical Assessment Body issuing the  
European Technical Assessment:

Deutsches Institut für Bautechnik

Trade name of the construction product

MAURER MSM® Spherical und Cylindrical Bearing

Product family  
to which the construction product belongs

Spherical and cylindrical bearing with special sliding  
material made of UHMWPE (Ultra high molecular weight  
polyethylene)

Manufacturer

MAURER PRO GMBH  
Frankfurter Ring 193  
80807 München  
DEUTSCHLAND

Manufacturing plant

Plan 1 to 5

This European Technical Assessment  
contains

31 pages including 24 annexes which form an integral  
part of this assessment

This European Technical Assessment is  
issued in accordance with Regulation (EU)  
No 305/2011, on the basis of

EAD 050004-01-0301

The European Technical Assessment is issued by the Technical Assessment Body in its official language. Translations of this European Technical Assessment in other languages shall fully correspond to the original issued document and shall be identified as such.

Communication of this European Technical Assessment, including transmission by electronic means, shall be in full. However, partial reproduction may only be made with the written consent of the issuing Technical Assessment Body. Any partial reproduction shall be identified as such.

This European Technical Assessment may be withdrawn by the issuing Technical Assessment Body, in particular pursuant to information by the Commission in accordance with Article 25(3) of Regulation (EU) No 305/2011.

## Specific Part

### 1 Technical description of the product

The MAURER MSM<sup>®</sup> Spherical and Cylindrical Bearing is a spherical or cylindrical bearing, which permits rotation and displacement movements by a flat and a curved sliding surface between bearing plates of steel (see Figures Annex A). The subject of the ETA is the complete bearing, including, if relevant, the necessary guides or restraints. As an alternative to the Figures in Annex A, the bearing may also be used upside down, i.e. with flat sliding surfaces lying below (meaningful, for example in the case of steel bridges).

The MAURER MSM<sup>®</sup> Spherical and Cylindrical Bearing is designed according to EN 1337-7 and may be combined with sliding elements according to EN 1337-2 as shown in EN 1337-1. Instead of PTFE according to EN 1337-2, MSM<sup>®</sup>, a special sliding material made of UHMWPE (Ultra high molecular weight polyethylene) with a melting temperature of at least 50 °C higher than the maximum operating temperature described below, suitable for low and high temperatures outside the scope of EN 1337-2 with improved wear resistance and load-bearing capacity, is used for the sliding surfaces of the bearing.

Sliding surfaces with a diameter of the circumscribing circle of special sliding material sheets less than 75 mm or greater than 3000 mm, or with operating bearing temperatures less than -50 °C or greater than +80 °C, are outside the scope of this ETA. Operating bearing temperatures above 48 °C are limited to short periods as due to climate temperature changes. If composite material is used in guides the maximum operating bearing temperature is limited to 48 °C.

Note: The operating bearing temperature is considered to be the shade air temperature as given in EN 1991-1-5.

Bearings with an included angle  $2\theta > 60^\circ$  for spherical and  $2\theta > 75^\circ$  respectively for cylindrical bearings are beyond the scope of this ETA.

The special metal sliding alloy MSA<sup>®</sup> may be used as mating surface. For operating bearing temperatures between -50 °C and +48 °C the sliding coating system MSC<sup>®</sup> may be used as mating surface.

#### Material combinations

The sliding materials in the bearing are combined as shown in Table 1. Only one combination is used in a sliding surface. The sliding surface is lubricated in accordance with EN 1337-2, clause 7.4.

Table 1: Combination of materials for permanent applications as sliding surfaces for spherical and cylindrical bearings with special sliding material MSM<sup>®</sup>

Flat surface		Curved surface		Guides	
dimpled MSM <sup>®</sup>	austenitic steel	dimpled MSM <sup>®</sup>	austenitic steel	undimpled MSM <sup>®</sup>	austenitic steel
	MSA <sup>®</sup>		hard chromium plating	CM1	austenitic steel
	MSC <sup>®</sup>		MSA <sup>®</sup>	CM2	
			MSC <sup>®</sup>		

The sliding surface may be subdivided in two restrained parts above and below the rotation element permitting in total the design movement, see the example in Annex A, Fig. A.7.

#### **MSM® sheets**

The composition of the material is confidential. Relevant information is laid down in Table 2, further details are laid down in the technical documentation to this ETA, deposited with the Technical Assessment Body.

The required geometrical characteristics of MSM® sheets and their confinement are given in Annex B. The curved MSM® sheet may be attached to either the convex or the concave backing plate.

#### **Composite material**

Instead of the undimpled MSM® sheets, only where self-alignment between the mating parts of the bearing is possible, composite materials CM1 and CM2 in accordance with either clause 5.3.1 or 5.3.2 of EN 1337-2 can be used in guides.

#### **Austenitic steel**

Austenitic steel sheets are in accordance with EN 1337-2, clause 5.4 and Annex C, clause C.4.

#### **Hard chromium plated surfaces**

Hard chromium plated surfaces are in accordance with EN 1337-2, clause 5.5.

#### **Sliding alloy MSA®**

Sliding alloy MSA® with special surface treatment may be used as an alternative to steel for backing plates in accordance with Annex D. The material characteristics and surface treatments of the sliding alloy MSA® are confidential and are laid down in the technical documentation to this ETA, deposited with the Technical Assessment Body.

#### **Sliding coating MSC®**

Sliding coating MSC® may be used as mating surface as an alternative to austenitic steel. The material, layer and surface characteristics of the sliding coating MSC® are confidential and are laid down in the technical documentation to this ETA, deposited with the Technical Assessment Body.

#### **Lubricant**

Silicon grease according to EN 1337-2, clause 5.8 is used as lubricant for sliding surfaces.

#### **Ferrous materials for backing plates**

The ferrous materials used for backing plates of the sliding surfaces are in accordance with EN 1337-2, clause 5.6.

#### **Attachment of sliding materials**

Attachment of sliding materials is in accordance with EN 1337-2, clause 7.2 and Annex C, clause C.4.

## 2 Specification of the intended use in accordance with the applicable European Assessment Document

The MAURER MSM<sup>®</sup> Spherical and Cylindrical Bearings are intended to be used for the support of bridges or building works in accordance with the scope of EN 1337-1 where the requirements on the individual bearing are critical.

The MAURER MSM<sup>®</sup> Spherical and Cylindrical Bearings are suitable for all types of structures but especially for non-rigid structures with relatively large and frequent displacements caused by working loads, next for superstructures that induce fast sliding displacements in bearings, e.g. in bridges for the high speed railways, as well as for regions with continuously low and/or high temperatures. Spherical and cylindrical parts made of sliding alloy MSA<sup>®</sup> are highly corrosion resistant.

The MAURER MSM<sup>®</sup> Spherical and Cylindrical Bearings are mainly used in concrete, steel and composite structures.

The performance given in Section 3 can only be assumed if the MAURER MSM<sup>®</sup> Spherical and Cylindrical Bearings are used in compliance with the specifications and under boundary conditions set out in Annexes.

The verifications and assessment methods on which this European Technical Assessment is based lead to an assumption of a working life of the MAURER MSM<sup>®</sup> Spherical and Cylindrical Bearings of at least 50 years. The working life of the bearing is reduced to 10 years, if in the bearing's guides the composite materials according to EN 1337-2 are used instead of the special sliding material MSM<sup>®</sup> in final use under ambient temperatures in indoor areas. The indications given on the working life cannot be interpreted as a guarantee given by the producer, but are to be regarded only as a means for choosing the right products in relation to the expected economically reasonable working life of the works.

### 3 Performance of the product and references to the methods used for its assessment

#### 3.1 Mechanical resistance and stability (BWR 1)

Essential characteristics	Method of assessment	Performance
Load bearing capacity	EAD, Clause 2.2.1	<i>Characteristic compressive strength <math>f_k</math></i> for all mating partners according to Table 1: See Annex C, Table C.1
		<i>Characteristic short-term compressive strength <math>f_{k,s-t}</math></i> for all mating partners according to Table 1: See Annex C, Table C.2
		<i>High temperature resistance of sliding elements:</i> Resistant up to 80 °C
Rotation capability	EAD, Clause 2.2.2	<i>Total rotation capability (see Annex E):</i> 10.000 m of accumulated slide path in the curved sliding surface for all mating partners according to Table 1 (see Annex E)
Displacement capacity	EAD, Clause 2.2.3	<i>Total displacement capacity (see Annex E):</i> 50.000 m of accumulated slide path in flat sliding surfaces for mating partner austenitic steel 10.000 m of accumulated slide path in flat sliding surfaces for mating partners MSA® or MSC® (Table 1) 10.000 m of accumulated slide path in guides for mating partner austenitic steel 2.000 m of accumulated slide path in guides for mating partner MSC® (Table 1)
Coefficient of friction	EAD, Clause 2.2.4	See Annex B
Resistance against corrosion and chemical and environmental influences	EAD, Clause 2.2.5	<i>Corrosion resistance:</i> Protective coating systems of ferrous materials with durability class "h" and following corrosivity categories (EN ISO 12944-1 and -2): - C5 (outdoor locations) or C4 (interior locations) Sliding alloy MSA®: - Durable in accordance with EN 1337-9 Sliding coating MSC®: - Corrosivity category C4, durability class "h" Provisions of EN 1337-2, Clause 7.3 for hard chromium plating have to be considered.
		<i>Resistance of the special sliding material MSM® and the special sliding coating MSC® against chemical and environmental influences:</i> Resistant

English translation prepared by DIBt

**4 Assessment and verification of constancy of performance (AVCP) system applied, with reference to its legal base**

According to the decision 95/467/EC of the European Commission, amended by the Commission Decision 2001/596/EC and 2002/592/EC, the system(s) of assessment and verification of constancy of performance (see Annex V of Regulation (EU) No 305/2011) is 1.

**5 Technical details necessary for the implementation of the AVCP system, as provided for in the applicable European Assessment Document**

Technical details necessary for the implementation of the AVCP system are laid down in the control plan deposited at Deutsches Institut für Bautechnik.

Issued in Berlin on 15 August 2019 by Deutsches Institut für Bautechnik

BD Dipl.-Ing. Andreas Kummerow  
Head of Department

*beglaubigt:*  
Hoppe

## Annex A

### Description of the product and its intended use

#### MAURER MSM<sup>®</sup> Spherical and Cylindrical Bearing (example)

Guided spherical bearing  
(moveable unidirectional)

Free spherical bearing  
(moveable multidirectional)

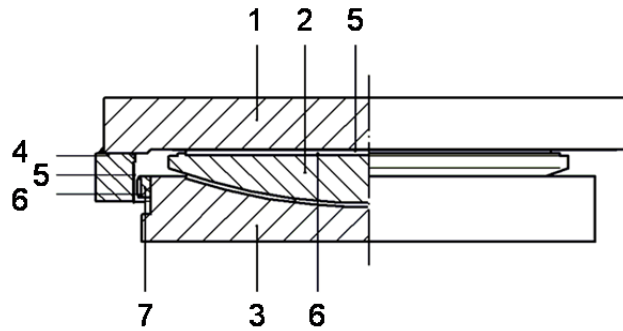

Guided cylindrical bearing  
(moveable unidirectional)

Free cylindrical bearing  
(moveable multidirectional)

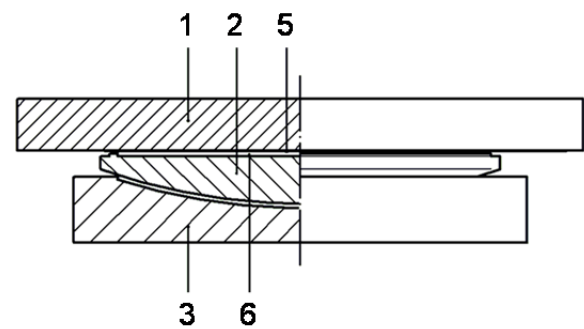
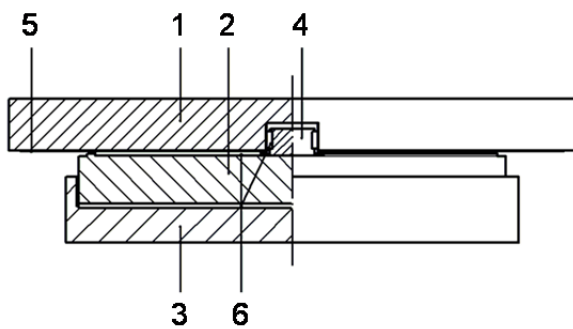

#### Key:

- |  |                                   |
|--|-----------------------------------|
| 1 Sliding plate                        | 5 Austenitic steel sheet          |
| 2 Rotational element (convex plate)    | 6 MSM <sup>®</sup> sheet or strip |
| 3 Bottom plate (concave backing plate) | 7 Rocker strip                    |
| 4 Guiding key                          |                                   |

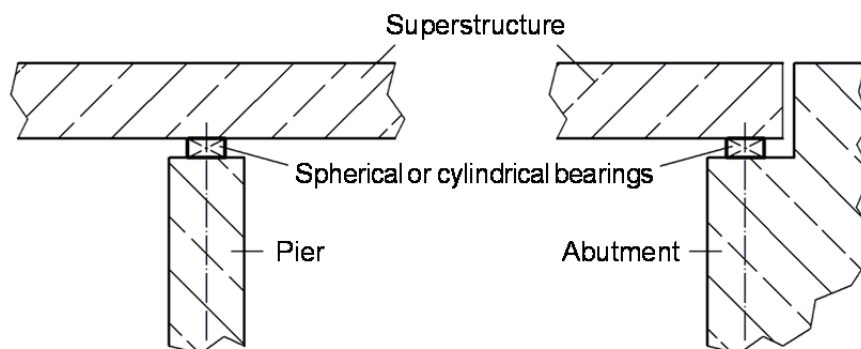

Figure A.1 - Assembly of a guided and free movable MAURER MSM<sup>®</sup> Spherical and Cylindrical Bearings and its intended use (example)



MAURER MSM<sup>®</sup> Spherical and Cylindrical Bearings consist of a backing plate with a convex spherical or cylindrical surface (rotational element) and a backing plate with a concave spherical or cylindrical surface between which a MSM<sup>®</sup> sheet and the mating material form a curved sliding surface (see Figure A.2 and A.4).

MAURER MSM<sup>®</sup> Spherical and Cylindrical Bearings are also used in combination with flat sliding elements and guides to form free and guided bearings (see Figure A.3 a) to d) and A.5 a) to c)). MAURER MSM<sup>®</sup> Spherical and Cylindrical Bearings combined with a flat sliding element can be used together with a restraining ring to form fixed bearings (see Figure A.3 d)).

Note: Numbers in brackets in Figures A.2 to A.5 refer to the examples shown in Figure 1 of EN 1337-1.

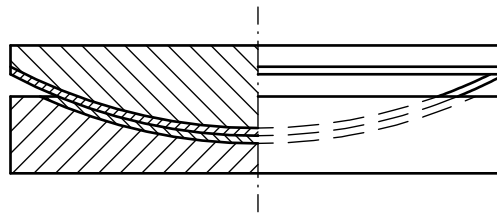

Fixed by sliding surface (3.2)

Figure A.2 - MAURER MSM<sup>®</sup> Spherical Bearing

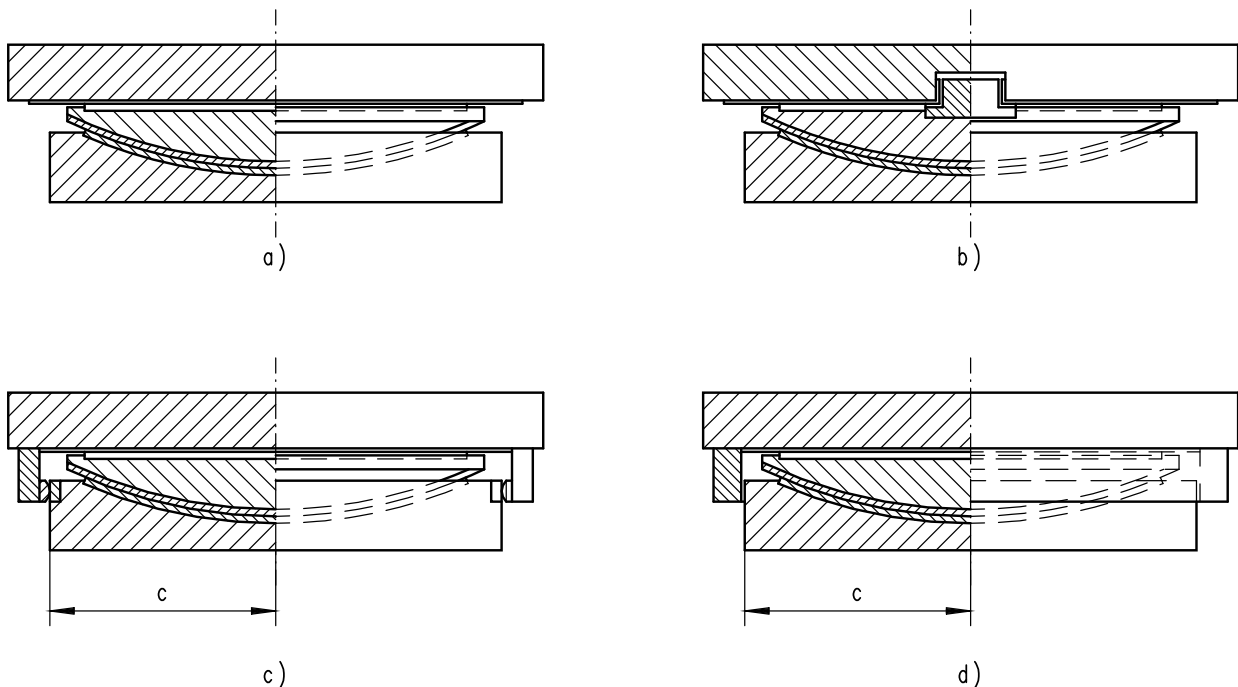

**Key:**

- a) Free for displacements in any direction (3.5)
- b) Guided by an internal guide for displacements in one direction (3.4)
- c) Guided by external guides in one direction (3.3)
- d) Fixed by a restraining ring (3.1)

Figure A.3 - MAURER MSM<sup>®</sup> Spherical Bearings combined with flat sliding elements

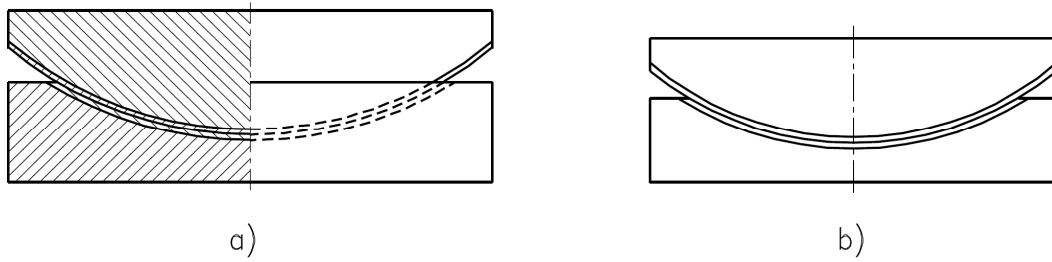

**Key:**

- a) Fixed by end stops and sliding surface (7.1)
- b) Without end stops for displacements in y-direction (7.2)

Figure A.4 - MAURER MSM<sup>®</sup> Cylindrical Bearings

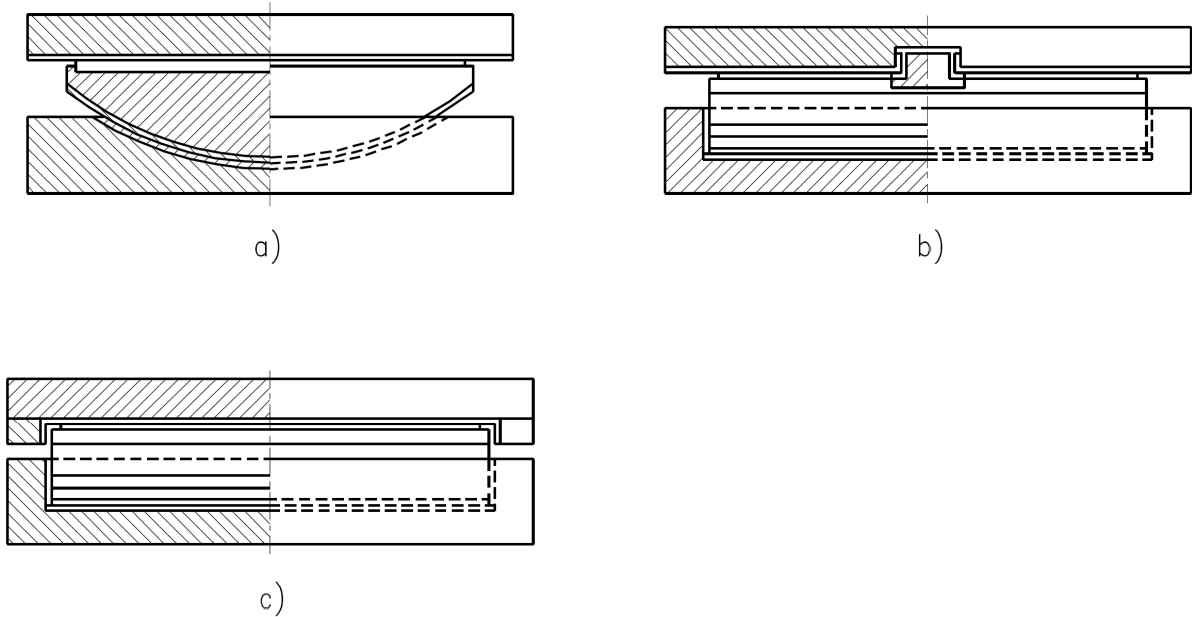

**Key:**

- a) Free for displacements in any direction (7.4)
- b) Guided by an internal guide for displacements in x-direction (7.3)
- c) Guided by external guides for displacements in x-direction

Figure A.5 - MAURER MSM<sup>®</sup> Cylindrical Bearings combined with flat sliding elements

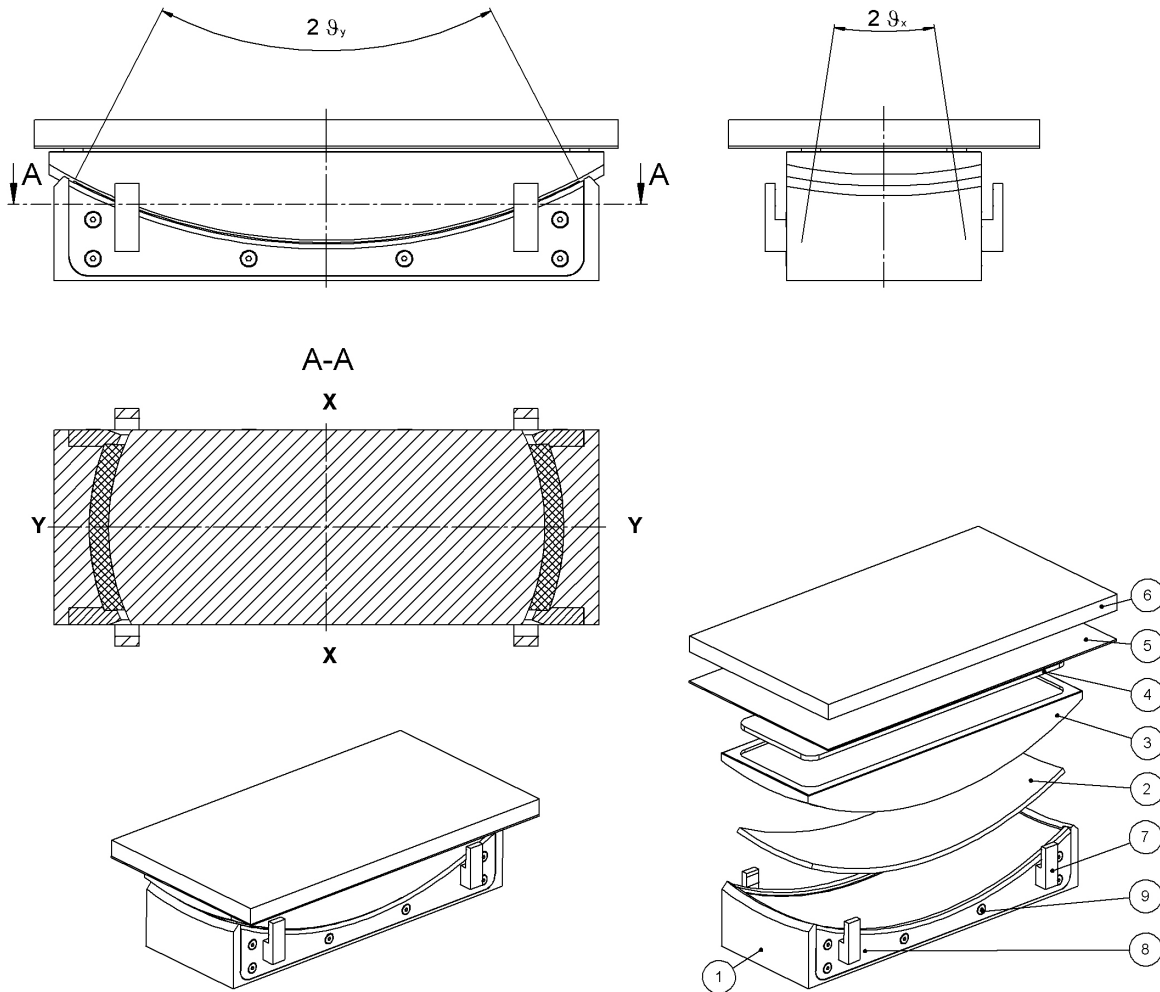

**Key:**

- 1 Lower backing plate
- 2 Curved MSM<sup>®</sup> sheet
- 3 Segmental spherical part
- 4 Flat MSM<sup>®</sup> sheet
- 5 Mating surface
- 6 Upper backing plate
- 7 Locking device
- 8 Lateral recess plate
- 9 Screw

Figure A.6 - MAURER MSM<sup>®</sup> Spherical Segment Bearing (example)

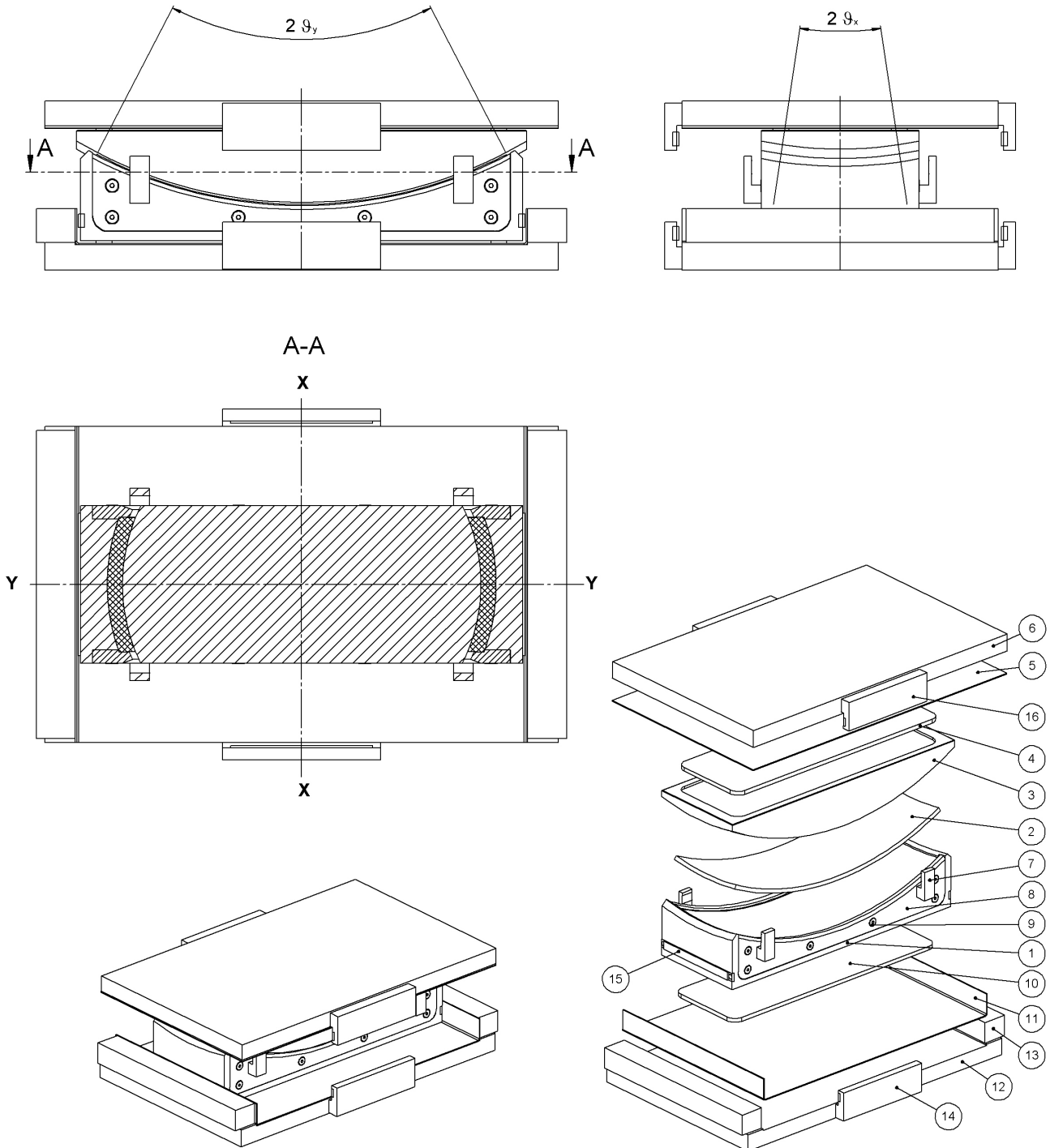

**Key:**

- |   |                          |    |                       |
|---|--------------------------|----|-----------------------|
| 1 | Lower backing plate      | 9  | Screw                 |
| 2 | Curved MSM® sheet        | 10 | Lower flat MSM® sheet |
| 3 | Segmental spherical part | 11 | Lower mating surface  |
| 4 | Upper flat MSM® sheet    | 12 | Lower Sliding plate   |
| 5 | Upper mating surface     | 13 | Guiding key           |
| 6 | Upper sliding plate      | 14 | Lower restraint       |
| 7 | Locking device           | 15 | MSM® strip            |
| 8 | Lateral recess plate     | 16 | Upper restraint       |

Figure A.7 - MAURER MSM® Spherical Segment Bearing with two sliding surfaces (example)

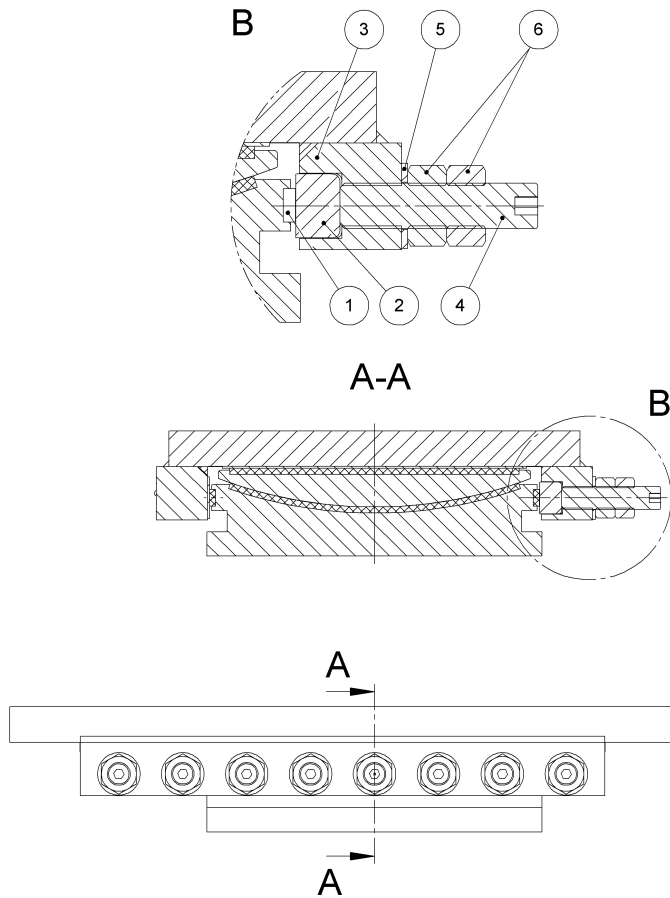

**Key:**

- 1 MSM® strip in guides
- 2 Austenitic steel bar
- 3 Guiding key
- 4 Threaded bolts
- 5 Washer
- 6 nut, lock nut

Figure A.8 - MAURER MSM® Bearings with adjustable guides (example)

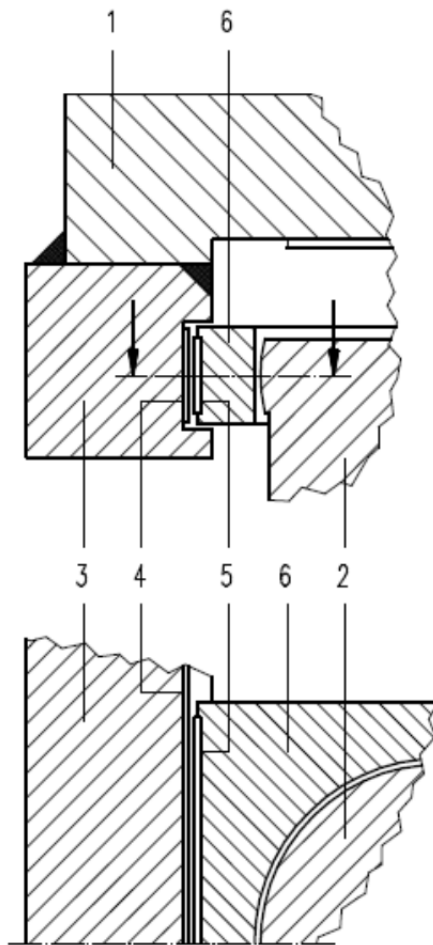

**Key:**

- 1 Sliding plate
- 2 Backing plate
- 3 Guiding key
- 4 Mating surface
- 5 MSM<sup>®</sup> or CM
- 6 Guide ring

Figure A.9 - MAURER MSM<sup>®</sup> Spherical Bearings with guided rotation ring (example)

## Annex B

### Sliding friction coefficient

The following coefficients of friction  $\mu_{max}$  shall be used for the design evaluation of the bearing. For the design of the structure in which the bearing is incorporated, the minimum friction value of cases (a) to (c) shall be applied. These values shall not be applied in the presence of high dynamic actions which may occur for instance in seismic zones. The effects of friction shall not be used to relieve the effects of externally applied horizontal loads.

#### (a) Coefficient of friction at low temperatures

For sliding elements combined with dimpled and lubricated MSM<sup>®</sup> sheets used in zones where the minimum operating bearing temperature doesn't fall below - 35 °C, the coefficient of friction  $\mu_{max}$  is determined as a function of the average pressure  $\sigma_{MSM}$  [MPa], as follows:

$$0.020 \leq \mu_{max} = \frac{1.6}{15 + \sigma_{MSM}} \leq 0.08$$

For guides, the coefficient of friction shall be considered to be independent of contact pressure. The coefficient of friction  $\mu_{max} = 0.10$  shall be used.

#### (b) Coefficient of friction at very low temperatures

For sliding elements combined with dimpled and lubricated MSM<sup>®</sup> sheets used in zones where the minimum operating bearing temperature does fall below - 35 °C (down to - 50 °C), the coefficient of friction  $\mu_{max}$  is determined as a function of the average pressure  $\sigma_{MSM}$  [MPa], as follows:

$$0.027 \leq \mu_{max} = \frac{2.8}{30 + \sigma_{MSM}} \leq 0.08$$

For guides, the coefficient of friction shall be considered to be independent of contact pressure. The coefficient of friction  $\mu_{max} = 0.12$  shall be used.

#### (c) Coefficient of friction at moderate low temperatures

For sliding elements combined with dimpled and lubricated MSM<sup>®</sup> sheets used in zones where the minimum operating bearing temperature doesn't fall below - 5 °C, the coefficient of friction  $\mu_{max}$  is determined as a function of the average pressure  $\sigma_{MSM}$  [MPa], as follows:

$$0.015 \leq \mu_{max} = \frac{1.2}{15 + \sigma_{MSM}} \leq 0.06$$

For guides the coefficient of friction shall be considered to be independent of contact pressure. The coefficient of friction  $\mu_{max} = 0.07$  shall be used.

For composite materials see clause 6.7 of EN 1337-2.

## Annex C

### Load bearing capacity (compressive strength)

#### C.1 Design verification for sliding surface

When dimensioning sliding surfaces, all the internal forces and moments due to actions and frictional resistance shall be considered. The design values of the action to be taken into account shall be determined in accordance with the basic design criteria given in EN 1337-1.

Deformation of sliding materials shall not be used to accommodate rotations except as permitted in C.2.

The following conditions shall be verified under the fundamental combination of actions:

$$N_{Sd} \leq \frac{f_k}{\gamma_m} \cdot A_r = \frac{f_k}{\gamma_m} \cdot \lambda \cdot A$$

where is:

$N_{Sd}$  design axial force

$f_k$  characteristic value of compressive strength acc. Table C.1

$\gamma_m$  partial safety factor for materials in accordance with EN 1990

$A$  contact area of the flat sliding surface or the projection of curved surfaces

$\lambda$  coefficient given in Annex G

$A_r$  reduced contact area of the sliding surface whose centroid is the point through which  $N_{Sd}$  acts with the total eccentricity  $e_t$ , which is caused by both mechanical and geometrical effects.  $A_r$  shall be calculated on the basis of the theory of plasticity assuming a rectangular stress block (see Annex G). For guides eccentricity can be neglected.

For the verification at the seismic combination of actions  $f_k$  may be replaced by  $f_{k,s-t}$ , the characteristic short-term compressive strength given in Table C.2, and  $\gamma_m$  shall be replaced by  $\gamma_{m,s-t}$ , the partial safety factor for short-term loads.

*Note: The  $\gamma_m$  value should be given in NDP (national determined parameter). In absence of NDP the recommended value is  $\gamma_m = 1.4$  and  $\gamma_{m,s-t} = 1.2$ .*

For MSM<sup>®</sup> sheets with smallest dimension  $L$ ,  $a$  or  $b$  in accordance with Annex F.1 larger or equal to 100 mm, contact areas  $A$  and  $A_r$  shall be taken as the gross area without deduction for the area of the dimples. For sheets with  $L$ ,  $a$  or  $b$  smaller than 100 mm the area of the dimples shall be deducted from the gross area.

The indication of products performance is based on the assessment under the conditions as given in clause 2.2.1 of the EAD.

The characteristic compressive strengths of MSM<sup>®</sup> are given in Table C.1 and are valid for operating bearing temperatures up to 80 °C. For bearings exposed to a maximum operating bearing temperature in excess of 35 °C and up to 80 °C the characteristic compressive strength shall be estimated by linear interpolation of the values given in the table C.1.

Table C.1: Characteristic compressive strength  $f_k$  of MSM<sup>®</sup>

Operating bearing temperature	≤ 35 °C	48 °C	70 °C <sup>1)</sup>	80 °C <sup>1)</sup>
<b>Sliding surface</b>	<b>Characteristic compressive strength <math>f_k</math></b>			
<b>Main sliding surface</b> Dead loads and variable loads	180 MPa	135 MPa	90 MPa	75 MPa
<b>Guides</b> Variable loads				
<b>Guides</b> Dead loads; Effects of temperature, shrinkage and creep	60 MPa	45 MPa	30 MPa	25 MPa
<sup>1)</sup> The use of MSC <sup>®</sup> as mating sliding surface is limited to a maximum operating temperature of 48 °C.				



For guides with composite material see 6.3 and 6.6 of EN 1337-2.

Table C.2: Characteristic short-term compressive strength of MSM<sup>®</sup>

<b>Maximum bearing temperature <math>T_{max, seismic}</math></b>	48 °C
<b>Sliding surface <sup>1)</sup></b>	<b>Characteristic short-term compressive strength <math>f_{k,s-t}</math></b>
<b>Main sliding surface</b> Short-term loads due to seismic events	240 MPa
<b>Guides</b> Short-term loads due to seismic events	
<sup>1)</sup> For sliding surfaces with MSC <sup>®</sup> as mating partner $f_k$ has to be used for verifications at the seismic combination of actions.	

For the purpose of compressive stress evaluation the curved sliding surface shall be replaced by its projection on a flat surface as shown in Figure C.1.

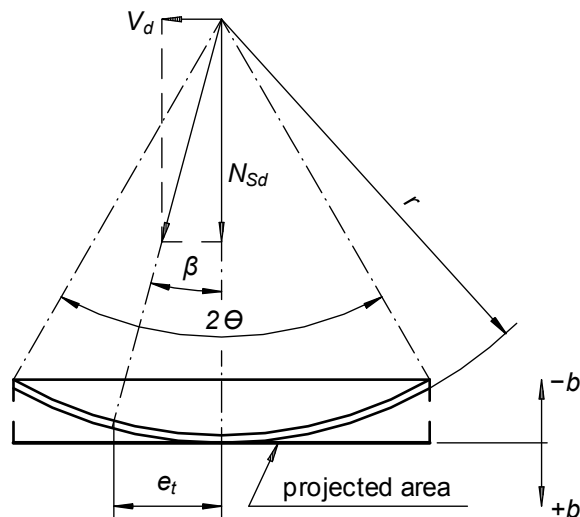

Figure D.1 - Evaluation scheme for the curved sliding surface (example)

Internal forces and moments acting on the curved sliding surface due to frictional resistance, externally applied horizontal loads and the rotated condition of the bearing shall be taken into account when determining the resulting total eccentricity  $e_t$  of the axial force  $N_{Sd}$ .

Secondary effects due to the action of the restraints shall also be considered.

*Note:* In Annex H, formulae are given for the evaluation of the eccentricities in the most common cases.

*Separation of sliding surfaces may lead to wear due to contamination and increased deformation due to lack of confinement of the MSM<sup>®</sup> sheet. As this could endanger long term fitness for use, the achievement of the edge pressure  $\sigma_{MSM} = 0$  is considered as serviceability limit state.*

With the exception of guides, it shall be verified that  $\sigma_{MSM} \geq 0$  under the characteristic combination of actions. In doing so the sliding material shall be assumed to be linear elastic and the backing plates shall be deemed to be rigid. The condition  $\sigma_{MSM} \geq 0$  is satisfied when the total eccentricity  $e_t$  falls within the kernel of the projected area.

For circular sheets this condition is satisfied when:

$$e_t \leq \frac{L}{8}$$

where

$L$  diameter see Annex F

## C.2 Guides

Guides may be used for resisting horizontal forces  $V_d$  due to variable and permanent actions. Depending on the bearing construction, the guides may be arranged externally or centrally. The sliding materials shall be fixed on keys and keyways in the backing plates.

Clearance  $c$  between sliding components in unused condition shall meet the following condition:

$$c \leq 1.0 \text{ mm} + \frac{L [\text{mm}]}{1000}$$

A typical example of the attachment of guides is shown in Figure A.1 of Annex A. In the design of the connection at ultimate limit state in accordance with EN 1993-1-1, the effects of horizontal force  $V_d$ , its induced moment and the friction forces shall be considered.

The maximum clearance in guides may be reduced due to adjustable guides. For this purpose high tensile screws in accordance with EN 1993 shall be used. The main principle of adjustable guides is shown in Annex A, Figure A.8.

Where, under the design rotation about transverse axis, under the characteristic combination of actions the differential deformation of the MSM<sup>®</sup> sheet across its smallest dimension "a" would exceed 0.2 mm, a rotation element shall be included in the backing plate (see EN 1337-1, clause 3.3, Figure 1). The rotation element shall be designed in accordance with the requirements of the mating surfaces of guides given in this ETA and pot to piston contact surfaces given in EN 1337-5.

## C.3 Restraining rings

The indication of products performance is based on the assessment under the following conditions:

The free MAURER MSM<sup>®</sup> Spherical and Cylindrical Bearing may be fixed by a steel restraining ring. The design shall be in accordance with EN 1337-5, clause 6.

## C.4 Austenitic steel sheets

The minimum thickness of austenitic steel sheet shall be in accordance with Table C.2.

The indication of products performance is based on the assessment under the following conditions:

- The austenitic steel sheet is fully in contact with the backing plate over the area which will be in contact with the MSM<sup>®</sup> sheet.
- When attaching the austenitic steel sheet by screwing, counterpunched screwing and riveting, corrosion resistant fasteners compatible with the austenitic steel sheet shall be used for securing its edges. They shall be provided at all corners and along the edges outside the area of contact with the MSM<sup>®</sup> sheet with the maximum spacing listed in Table C.3.

Table C.2: Thickness and methods of attachment of austenitic steel sheets.

Type of surface	Method of attachment	Thickness [mm]
flat	full surface bonding	1.5
	continuous fillet weld	≥ 1.5
	counterpunched screwing	≥ 1.5
	screwing, riveting	≥ 2.5
spherical	full surface bonding	≥ 2.5
	continuous fillet weld	≥ 2.5
	recessed in concave surfaces	≥ 2.5
cylindrical	full surface bonding	≥ 1.5
	continuous fillet weld	≥ 1.5
	recessed in concave surfaces	≥ 2.5

Table C.3: Maximum fastener spacing for attachment of austenitic steel sheets by screwing, counterpunched screwing and riveting.

Austenitic steel sheet thickness [mm]	Maximum fasteners spacing [mm]
1.5	150
2.0	300
2.5	450
3.0	600

## Annex D

### Load - deformation behaviour

The indication of products performance is based on the assessment under the following conditions:

- The MSM<sup>®</sup> and the mating sliding materials shall be supported by metallic plates (backing plates) with flat or curved surfaces.
- The geometrical conditions are given in Annex I.

The design of the backing plates shall take into account the following:

- verification for the fundamental combination of actions when internal forces and moments from lateral actions are to be considered in addition to the effects from deformation as per hereafter,
- any cross section reduction (for example due to keyway and the attachment bolts),
- deformations as per hereafter,
- the required stiffness for transport and installation as per hereafter,
- distribution of forces to the adjacent structural members as per hereafter.

*Note: If the deformations (see Figure D.1) exceed the values given below, unacceptably small clearance between the adjacent backing plates and higher wear will occur. As this could endanger the long term fitness for use of the sliding element, this condition is considered serviceability limit state.*

The deformation  $\Delta w$  (see Figure D.1) shall meet the following condition:

$$\Delta w \leq h \left( 0.45 - 1.708 k \sqrt{\frac{h}{L}} \right) \text{ with } 0 \leq 1.708 k \leq 1.0 \text{ and } k = \frac{\sigma_{MSM} [\text{MPa}] - 45}{78.5}$$

where is

$L, h$  see Annex F

$\sigma_{MSM}$  average pressure in the sliding surface under the characteristic combination of action

$k$  stiffness coefficient depends on sliding material

The stress in the backing plate induced by the respective deformation shall not exceed the yield stress in order to avoid permanent deformations. The theoretical model for evaluation of the above requirements (deformation  $\Delta w$  and yield strength) shall include the effects of all the bearing components which have a significant influence on these deformations including the adjacent structural members and their short and long-term properties.

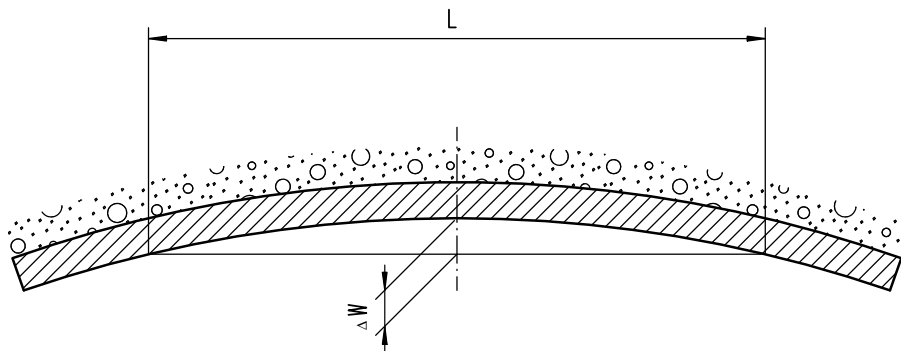

Figure D.1 - Deformations of backing plates.

For steel and concrete, the design values of material properties in accordance with EN 1993-1-1 and EN 1992-1-1, respectively, apply.

In this model the following assumptions shall be made:

- a) central load;
- b) notional design modulus of elasticity of MSM<sup>®</sup> = 900 MPa;
- c) the total thickness  $t_{MSM}$  of MSM<sup>®</sup> sheet;
- d) notional design Poisson's ratio of MSM<sup>®</sup> = 0.44;
- e) in the case of adjacent structural members of solid construction: linear reduction of the elastic modulus of concrete or mortar from the edge to the centre of the backing plate from 100% to 80%.

A suitable method for calculating deformation  $\Delta w$  for common materials is given in Annex I, clause I.5.

When using the method given in Annex I yield stress evaluation of the backing plate is not required if:

- the condition for the deformation  $\Delta w$  is met;
- the concrete strength class is at least C25/30 in accordance with EN 206-1;
- and the steel grade is at least S355 in accordance with EN 10025.

The above also applies when using lower concrete strength classes and/or steel grades, provided the deformation limit values calculated as above are reduced by a factor of:

- 0.90 when using concrete strength class C20/25
- 0.67 when using steel S235
- 0.60 when using both concrete C20/25 with steel S235.

*Note: The above is not the only criterion to be considered in determining the relative deformation  $\Delta w$ . Particular attention shall be paid to loadings during construction (e.g. when large backing plates are not propped during concrete casting).*

The calculation of the relative deformation of the backing plate with convex surface shall be omitted.

Square or rectangular plates shall be idealised to circular plates of diameter

$$d_b = 1.13 \cdot a_b$$

where  $a_b$  is the side of the square plate or the minor side of the rectangular plate.

The thickness of the backing plate shall be:

$$t_b \geq 0.04 \cdot \sqrt{a_b^2 + b_b^2}$$

or 10 mm, whichever is greater, where:

$a_b$  is the minor side of backing plate and

$b_b$  is the major side of backing plate.

## Annex E

### Rotation capability and displacement capacity of MAURER MSM<sup>®</sup> Spherical and Cylindrical Bearings

#### E.1 Rotation capability

The indication of products performance regarding the sliding surfaces is based on the assessment under conditions given in this ETA.

Under the fundamental combination of actions it shall be shown that:

- the metallic surfacing mating with the MSM<sup>®</sup> material shall completely cover the MSM<sup>®</sup> sheet,
- there is no contact between the upper and the lower part of the bearing or any other metallic component (see EN 1337-1, Annex A).

Concerning the above conditions the increase of rotations, specified in clause 5.4 of EN 1337-1, shall be taken into account.

For rotations about a transverse axis of guides see Annex C, clause C.2.

For guides with composite material see clause 6.3 of EN 1337-2.

For MAURER MSM<sup>®</sup> Spherical Bearings with external guides the rotation capability around the vertical axis may be increased using a guide ring, see Figure A.9 of Annex A. The contact surfaces of this guide ring are designed in accordance with the requirements given in Annex C, clause C.3.

#### E.2 Displacement capacity

The single, maximum displacement capacity is given by the geometrical design of the sliding elements. By taking into account the increased movements according to 5.4 in EN 1337-1, it shall be verified under the fundamental combination of actions that with maximum displacement of the sliding element the mating sliding partner completely covers the MSM<sup>®</sup> or CM sheets, respectively.

The intended working life of 50 years of MAURER MSM<sup>®</sup> Spherical and Cylindrical Bearings corresponds to Working Life Category 3 (see Table E.1). Its estimation is based on the two different maximum design values of accumulated slide path per year  $S_{Ay,d}$  for buildings and bridges and the corresponding recommended mating partner in flat sliding surfaces given in Table E.2.

Table E.1: Working Life Category of structural bearings

Working Life Category	Years
1	10
2	25
3	50
4	100

Table E.2: Recommended mating partner in sliding surfaces depending on the type of structure

Type of structure	Design accumulated slide path per year $S_{Ay,d}$	Recommended mating partner in sliding surfaces		
		flat	curved	guides
Buildings	$\leq 200$ m/year	MSA <sup>®</sup> , MSC <sup>®</sup>	all materials according to Table 1	MSC <sup>®</sup>
Bridges	$\leq 1000$ m/year	Austenitic steel		Austenitic steel

## Annex F

### Geometrical characteristics of MSM® sheets

#### F.1 Details of recess and relief for sliding elements with MSM®

The performance characteristics of MAURER MSM® Spherical and Cylindrical Bearings given in this ETA are valid only for the following geometrical conditions.

For MAURER MSM® spherical bearings the absence of two symmetrical circular segments for not subdivided sheets is permissible, if the limitation for the included angle given in clause 1 and the proof of non separation of the sliding surfaces given in Annex C, clause C.1 is fulfilled for both the main axes. The main principle of MAURER MSM® spherical segment bearings is shown in Annex A, Fig. A.6 and A.7.

##### F.1.1 Recessed MSM® sheets

The MSM® sheets shall be recessed into a backing plate as shown in Figure G.1.

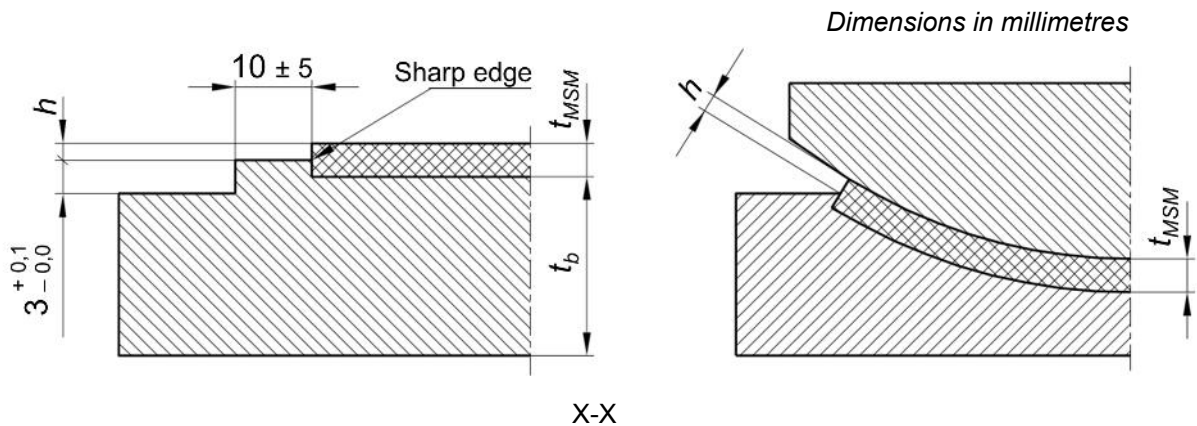

Figure G.1 - Details of MSM® recess and relief

*Note: A fixed value for the depth of the relief is given to facilitate the measurement of the MSM® protrusion  $h$  after installation. For section X-X, see figure F.2 resp. F.3.*

The thickness  $t_{MSM}$  and protrusion  $h$  of the MSM® sheet in the unloaded condition with corrosion protection shall meet the conditions given in Table F.1

Table F.1: Thickness  $t_{MSM}$  and protrusion  $h$  of the MSM® sheet

Design values	Flat and curved sliding surfaces	Guides
Thickness $t_{MSM}$ in mm	$2.65 \cdot h \leq t_{MSM} \leq 10.0$ (with $h$ in mm)	$8.0 \leq t_{MSM} \leq 10.0$
Protrusion $h$ in mm	$h = 2.50 + \frac{L}{3000}$ $L$ diameter of the projected area of the MSM® sheet in mm	$h = 3.0 \pm 0.2$

The tolerance on the protrusion  $h$  is  $\pm 0.2$  mm for  $L \leq 1200$  mm and  $\pm 0.3$  mm for  $L > 1200$  mm. The protrusion  $h$  shall be verified at marked measuring points, where the corrosion protection coating shall not exceed 300  $\mu\text{m}$ . There shall be at least two measuring points, suitably located.

The admissible tolerance on thickness  $t_{MSM}$  of single MSM<sup>®</sup> sheets or associated multiple sheets is:

- $+0,3$   
 $-0,0$  mm for sheets with a diameter  $L \leq 1200$  mm and
- $+0,4$   
 $-0,0$  mm for sheets with a diameter  $L > 1200$  mm.

### F.1.2 Flat MSM<sup>®</sup> sheets

Flat MSM<sup>®</sup> sheets for the main sliding surface shall be circular and may be sub-divided into a maximum of four identical parts. Further sub-divisions are beyond the scope of this ETA. The smallest dimension "a" shall not be less than 50 mm. The distance between individual MSM<sup>®</sup> sheets shall not be greater than twice the thickness of the backing plate of the MSM<sup>®</sup> or the mating material, whichever is least. Figure F.2 shows some examples of sub-division of flat MSM<sup>®</sup> sheets.

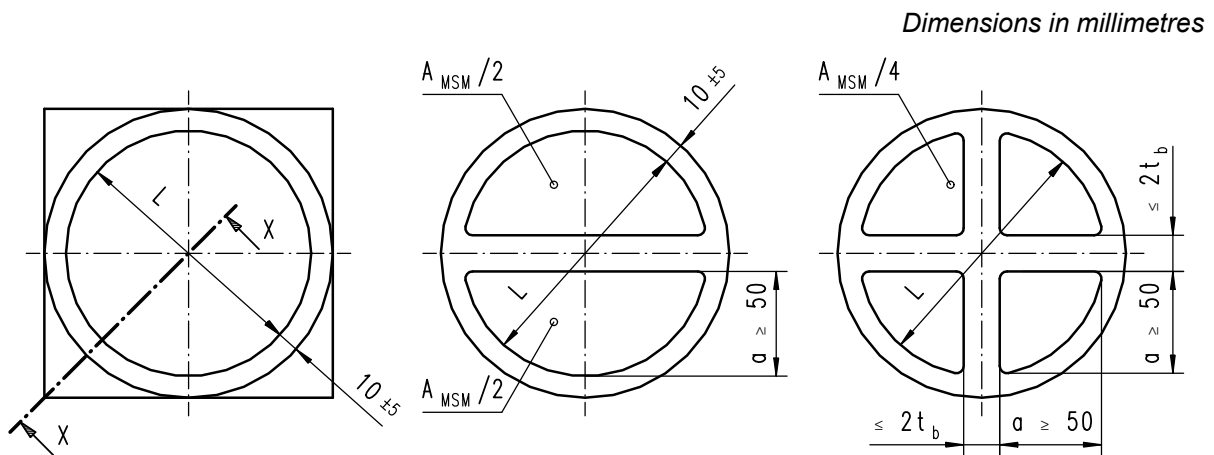

Figure F.2 - Examples of recessed flat MSM<sup>®</sup> configurations

### F.1.3 Curved MSM<sup>®</sup> sheets

Curved MSM<sup>®</sup> sheets shall be circular and may be subdivided into a disc and an annulus. If the curved sliding sheet is subdivided, the diameter  $d$  shall not be less than 1000 mm or  $2/3 \cdot L$ , whichever is greater, and the width of the annulus shall not be less than 50 mm. The annulus may be divided into equal segments. Both the disc and the annulus may be retained in recesses. The separating ring of the backing plate shall not be more than 10 mm wide. Figure F.3 shows the configurations of curved MSM<sup>®</sup> sheets for spherical sliding surfaces.

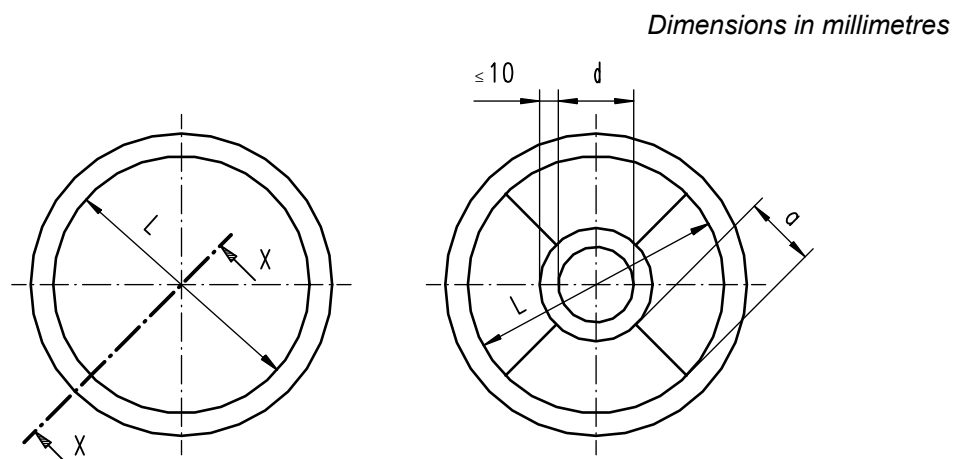

Figure F.3 - Subdivision of recessed MSM<sup>®</sup> sheets for spherical sliding surfaces



Curved MSM<sup>®</sup> sheets for cylindrical sliding surfaces shall be rectangular and may be subdivided into a maximum of two identical parts. Figure 4 of EN 1337-2 shows the configurations of curved MSM<sup>®</sup> sheets for cylindrical sliding surfaces.

#### F.1.4 MSM<sup>®</sup> sheets for MAURER Multisurface Spherical Bearings

As an alternative to the geometrical rules given above flat and curved surfaces of spherical bearings made of MSM<sup>®</sup> may consist of one centric circular sheet with diameter  $a$  and one or more concentric annuli with a constant width  $b$ . The dimensions  $a$  and  $b$  shall not be smaller than 50 mm. The radial distance  $f$  between the individual sheets shall not be less than 10 mm and not greater than twice the thickness of the backing plate of the MSM<sup>®</sup> sheet or the backing plate of the mating material, whichever is least. The annuli may be subdivided into segments. Both the disc and the annulus may be retained in recesses. Figure F.4 shows the configurations of flat and curved MSM<sup>®</sup> sheets for MAURER MSM<sup>®</sup> Multisurface Spherical Bearings.

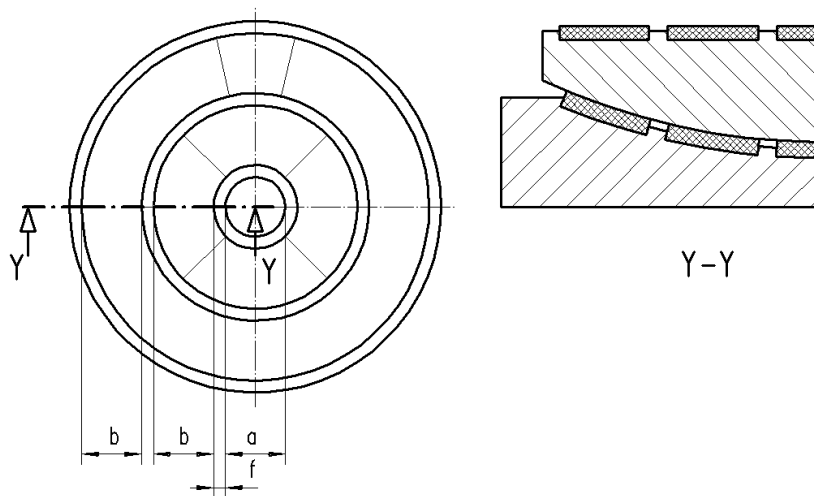

Figure F.4 - Subdivision of recessed MSM<sup>®</sup> sheets for MAURER MSM<sup>®</sup> Multisurface Spherical Bearings (Example)

#### F.1.5 MSM<sup>®</sup> sheets for guides

Dimension  $a$  is not less than 15 mm and the modified shape factor

$$S = \frac{A_{MSM}}{u \cdot h} \cdot \frac{t_{MSM} - h}{h}$$

is greater than 4 (see figure F.5).  $A_{MSM}$  is the compressed (undeformed) surface and  $u$  the perimeter of the MSM<sup>®</sup> sheet.

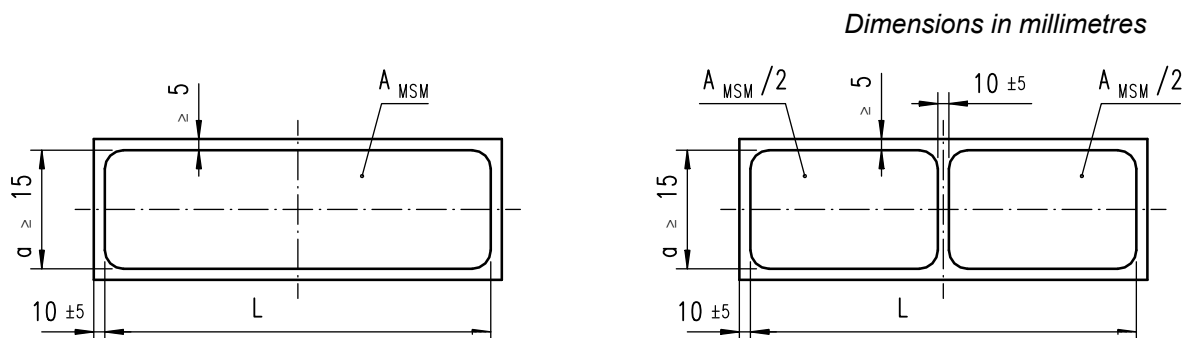
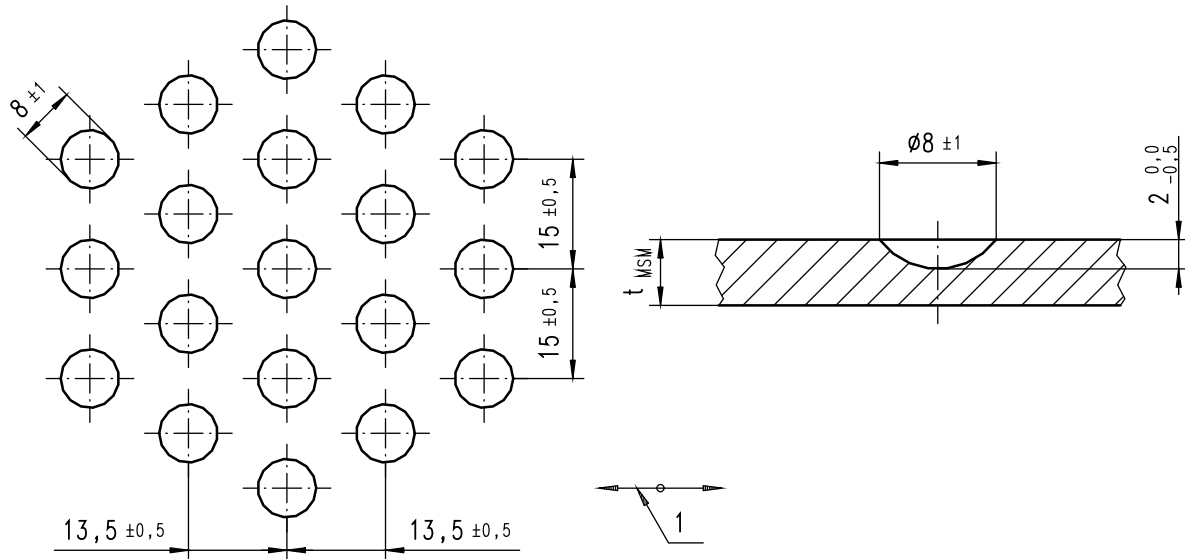

Figure F.5 - Examples of recessed MSM<sup>®</sup> sheets for guides

## F.2 Dimple pattern for sliding elements with MSM<sup>®</sup>

For pressures due to characteristic permanent actions  $G_k$  exceeding 5 MPa a uniform pattern of dimples shall be provided to retain the lubricant. The shape and arrangement of the dimples in the unloaded and unused condition and the alignment with the main direction of sliding is shown in figure F.6.

*Dimensions in millimetres*



**Key:**

1 Main direction of sliding

Figure F.6 - Pattern of dimples in recessed MSM<sup>®</sup> sheets

## Annex G

### Reduced area for circular sliding elements

This annex gives the values of the coefficient  $\lambda$  used in Annex C for the calculation of the reduced area  $A_r$  of curved sliding surfaces. The values of the coefficient  $\lambda$  have been calculated by means of a mathematical model made with the following assumptions:

- 1) only compressive stresses are transmitted;
- 2) the stresses in the compressed area are constant and equal to the design value  $f_d$  of compressive resistance of MSM<sup>®</sup> sheets (i.e. the stress block theory is adopted);
- 3) stresses are always normal to the contact surface: a conservative hypothesis justified by the low coefficient of friction of MSM<sup>®</sup> in contact with polished metal surfaces;
- 4) the adjacent backing plates are perfectly rigid.

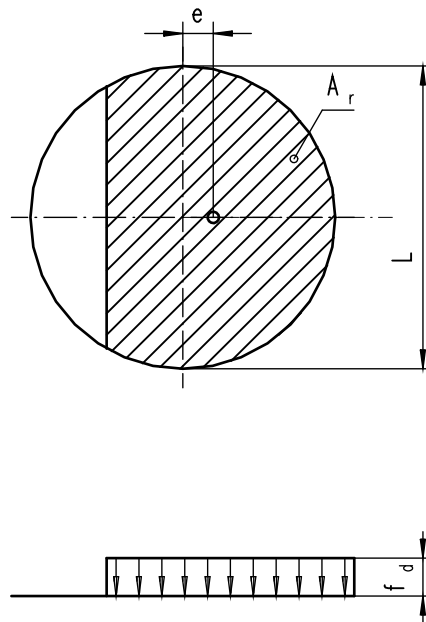

Figure G.1 - Reduced contact area  $A_r$  for circular sliding surfaces.

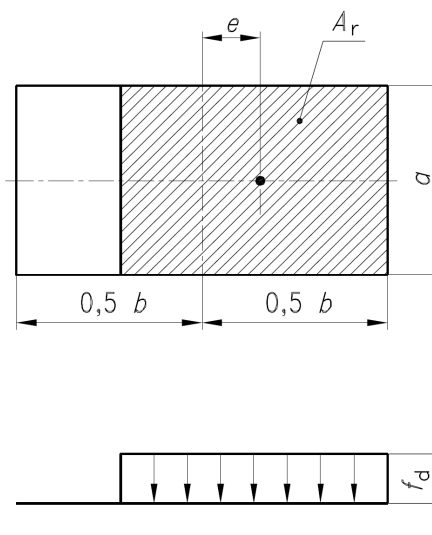

Figure G.2 - Reduced contact area  $A_r$  for rectangular sliding surfaces.

$$A_r = \lambda \cdot A$$

where is

$\lambda$  Coefficient given in Table G.1.

A Contact area for flat sliding surfaces or projection area of the curved sliding surface

$$A = \pi \cdot L^2 / 4$$

As an alternative to the exact values given in Table G.1, the following approximate formula can be used for flat sliding surfaces:

$$\lambda = 1 - 0.75 \pi \cdot e / L$$

Table G.1 - Coefficient  $\lambda = A_r / A$

e / L	sliding surface								
	flat	spherical				cylindrical			
		$\theta$							
		30°	25°	20°	10°	30°	25°	20°	10°
0.000									
0.050	0.990	0.991	0.991	0.990	0.990				
0.010	0.979	0.982	0.981	0.980	0.979	0.984	0.983	0.981	0.980
0.020	0.957	0.962	0.961	0.960	0.958	0.968	0.965	0.962	0.961
0.030	0.934	0.942	0.940	0.938	0.936	0.951	0.947	0.943	0.941
0.040	0.912	0.922	0.919	0.916	0.913	0.934	0.929	0.924	0.921
0.050	0.888	0.901	0.898	0.894	0.890	0.917	0.911	0.905	0.901
0.060	0.865	0.880	0.876	0.872	0.867	0.900	0.893	0.886	0.881
0.070	0.841	0.858	0.853	0.849	0.844	0.882	0.874	0.866	0.862
0.080	0.818	0.836	0.831	0.826	0.820	0.864	0.855	0.847	0.842
0.090	0.793	0.814	0.808	0.803	0.796	0.846	0.837	0.827	0.822
0.100	0.769	0.792	0.786	0.780	0.773	0.828	0.818	0.808	0.802
0.110	0.745	0.770	0.763	0.757	0.749	0.809	0.799	0.788	0.782
0.120	0.722	0.747	0.740	0.733	0.724	0.790	0.779	0.768	0.762
0.125	0.709	0.736	0.729	0.722	0.712	0.780	0.769	0.758	0.752
0.130	0.697	0.725	0.717	0.710	0.700	0.771	0.760	0.749	0.742
0.140	0.673	0.702	0.693	0.686	0.676	0.752	0.740	0.729	0.722
0.150	0.649	0.680	0.670	0.663	0.653	0.733	0.721	0.709	0.702
0.160	0.625	0.657	0.647	0.639	0.628	0.713	0.701	0.689	0.682
0.170	0.601	0.635	0.624	0.616	0.604	0.693	0.681	0.669	0.662
0.180	0.577	0.612	0.601	0.592	0.581	0.673	0.661	0.649	0.642
0.190	0.552	0.590	0.578	0.569	0.557	0.653	0.641	0.629	0.622
0.200	0.529	0.567	0.556	0.546	0.533	0.633	0.621	0.609	0.602
0.210	0.506	0.545	0.533	0.523	0.510	0.612	0.600	0.589	0.582
0.215	0.500	0.541	0.529	0.518		0.602	0.590	0.579	0.572
0.220	0.482	0.523	0.511	0.500		0.592	0.580	0.569	0.562
0.230	0.458	0.501				0.571	0.559	0.548	0.542
0.240	0.435					0.550	0.539	0.528	0.522
0.250	0.412					0.529	0.518	0.508	0.502

*Note: Intermediate values may be obtained by linear interpolation*

## Annex H

### Method for calculation the eccentricities in MAURER MSM<sup>®</sup> Spherical and Cylindrical Bearings

#### H.1 General

Frictional forces, forces from applied horizontal loads and the rotated condition of the bearing produce eccentricity of the axial force  $N_s$ , which is used in the verification of MSM<sup>®</sup> sheets, the adjacent structural members and the anchoring devices. This annex gives methods for calculating the significant eccentricities. Depending on the design features of a particular bearing, additional eccentricities may exist. When several eccentricities occur in a cross-section under consideration, they need to be added.

#### H.2 Friction resistance

##### H.2.1 Curved sliding surfaces

In the presence of rotational movements an internal moment occurs due to the frictional resistance. Regardless of whether the bearing has one or two surfaces, the associated eccentricity  $e_1$  is:

$$e_1 = \mu_{max} \cdot r$$

The coefficient of friction  $\mu_{max}$  is given in Annex B.

##### H.2.2 Sliding surfaces with external guides and restraining rings

For the spherical and cylindrical bearings of the type shown by Figures A.3 c) and d) in Annex A rotational movements produce an eccentricity which affects only the adjacent structural members (i.e. plinth, beam etc.) and the anchoring devices, where:

$$e_2 = \frac{V_d}{N_{Sd}} \cdot \mu_{max} \cdot c$$

For bearings with sliding elements in guides as per Table 1, the coefficient of friction  $\mu_{max}$  is given in Annex B. For restraining rings with steel to steel contact  $\mu_{max}$  should be assumed to be 0.2.

#### H.3 Rotation

In all the types of bearings with two sliding surfaces a rotation angle  $\alpha$  produces an eccentricity  $e_3$  of the vertical load on the curved surface equal to:

$$e_3 = \alpha \cdot (r + b)$$

where  $b$  represents the distance between the cross-section under consideration and the sliding surface. At any rate, this eccentricity acts nonetheless in the opposite direction to that given under Annex C. The occurrence of  $e_3$  depends on whether the curved MSM<sup>®</sup> sheet is either attached to the convex or concave backing plate and whether the value  $\alpha$  is greater or lesser than  $\mu$  as well as on whether the bearing clearance is performing its function effectively in the case of guided bearings. In the type of bearings equipped with only one sliding surface  $e_3$  occurs only in the curved MSM<sup>®</sup> sheet and, furthermore, only when said sheet is attached to the convex backing plate.

#### H.4 Lateral forces

Lateral forces result from horizontal actions and the friction resistance of the other bearings in the structure. In bearings where lateral forces are transmitted by external guides or restraining rings, the eccentricity in the curved sliding surface is equal to zero. In bearings of the fixed type with only one sliding surface or with internal guides the horizontal load  $V_s$  produces an eccentricity given by:

$$e_4 = \frac{V_d}{N_{Sd}} \cdot (r + b)$$

In all cases where the lines of application of lateral action and reaction are not coincident the resulting couple causes an eccentricity that shall be additionally taken into account.

## Annex I

### Backing plates

#### I.1 General

Dimensional limitations of backing plates with concave surfaces are shown in Figure I.1.

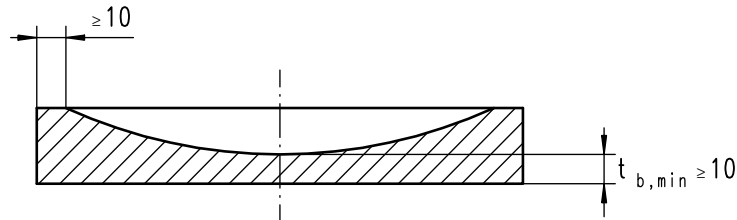

Figure I.1 - Dimensional limitations of a backing plate with a concave surface

#### I.2 MSM<sup>®</sup> confinement

The shoulders of the recess shall be sharp and square to restrict the flow of MSM<sup>®</sup> (see Annex F, Figure F.1). The radius at the root of the recess shall not exceed 1 mm. The depth of the confining recess shall be related to the dimensions of the MSM<sup>®</sup> sheet in accordance with Annex F. In principle the MSM<sup>®</sup> sheet shall fit the recess without clearance. Intermittent gaps between the edge of the MSM<sup>®</sup> sheet and the recess shall not exceed the values given in Table I.1 at room temperature.

Table I.1 - Fit of confined MSM<sup>®</sup> sheets.

Dimension $L$ [mm]	Gap [mm]
$75 \leq L \leq 600$	0.6
$600 < L \leq 1200$	0.9
$1200 < L \leq 1500$	1.2

where is

$L$  Diameter according to Annex F

For diameters  $L > 1500$  mm the gaps are limited to  $L$  [mm] / 1250

#### I.3 Flatness

Surfaces of backing plates in contact with sliding materials or anchor and shimming plates shall be treated in such a way that the maximum deviation  $\Delta z$  from theoretical flat surface shall not exceed  $0.0003 \cdot d$  or 0.2 mm, whichever is greater.

#### I.4 Fit of sliding surfaces

The maximum deviation  $\Delta z$  from theoretical flat or curved surface within the area of the mating MSM<sup>®</sup> sheet shall not exceed  $0.0003 \cdot L$  or 0.2 mm, whichever is greater.

### I.5 Method for calculating the deformation of backing plates attached to concrete

For circular metallic plates attached to concrete structural members of concrete strength class C20/25 according to EN 206-1 or greater and mortar layers of equivalent strength, the maximum relative deformation  $\Delta w$  over the diameter  $L$  is given by the equation below:

$$\Delta w = \frac{0.55}{L} \cdot k_c \cdot \alpha_c \cdot k_b \cdot \alpha_b$$

with

$$k_c = 1.1 + (1.7 - 0.85 \cdot d_b/L) \cdot (2 - d_b/L_0) \quad \text{if } L_0 \leq d_b \leq 2 \cdot L_0$$

$$k_c = 1.1 \quad \text{if } d_b > 2 \cdot L_0$$

$$\alpha_c = \frac{N_{Qd}}{E_{cd}} + \frac{N_{Gd}}{E_{crd}}$$

$$k_b = 0.30 + (0.55 \cdot d_b/L)$$

$$\alpha_b = \left( \frac{L}{L + 2 \cdot t_b} \right)^2 \cdot \left( \frac{3 \cdot L_0}{d_b} \right)^{0.4}$$

where is

$d_b$  diameter of the backing plate

$t_b$  thickness of the backing plate; for backing plates with a concave surface the calculation may be based on the equivalent constant thickness

$$t'_b = t_{b,min} + 0.6 (t_{b,max} - t_{b,min})$$

$L$  diameter of MSM<sup>®</sup> sheet

$L_0$  reference diameter = 300 mm

$N_{Qd}$  design axial force due to variable actions

$N_{Gd}$  design axial force due to permanent actions

$E_{cd}$  design secant modulus of elasticity of concrete

$E_{crd}$  design reduced modulus of elasticity of concrete, for the determination of creep when acted upon by permanent design actions  $N_{Gd}$  ( $E_{crd} \cong 1/3 E_{cd}$ )

The above approximate procedure may also be applied to square plates and rectangular plates if they are idealised to circular plates of diameter

$$d_b = 1.13 a_b$$

where  $a_b$  is the side of the square plate or the minor side of the rectangular plate.