

Approval body for construction products  
and types of construction

Bautechnisches Prüfamt

An institution established by the Federal and  
Laender Governments



## European Technical Assessment

ETA-10/0215  
of 22 January 2020

English translation prepared by DIBt - Original version in German language

### General Part

Technical Assessment Body issuing the  
European Technical Assessment:

Deutsches Institut für Bautechnik

Trade name of the construction product

String stair system Treppenmeister

Product family  
to which the construction product belongs

Prefabricated stair with steps and strings made of solid  
wood for use as an indoor stair in buildings

Manufacturer

Treppenmeister GmbH  
Emminger Straße 38  
71131 Jettingen  
DEUTSCHLAND

Manufacturing plant

Treppenmeister, Plant 1 to 85

This European Technical Assessment  
contains

17 pages including 3 annexes which form an integral part  
of this assessment

This European Technical Assessment is  
issued in accordance with Regulation (EU)  
No 305/2011, on the basis of

EAD 340006-00-0506

This version replaces

ETA-10/0215 issued on 12 February 2018

The European Technical Assessment is issued by the Technical Assessment Body in its official language. Translations of this European Technical Assessment in other languages shall fully correspond to the original issued document and shall be identified as such.

Communication of this European Technical Assessment, including transmission by electronic means, shall be in full. However, partial reproduction may only be made with the written consent of the issuing Technical Assessment Body. Any partial reproduction shall be identified as such.

This European Technical Assessment may be withdrawn by the issuing Technical Assessment Body, in particular pursuant to information by the Commission in accordance with Article 25(3) of Regulation (EU) No 305/2011.

## Specific Part

### 1 Technical description of the product

The string Stair system Treppenmeister is a prefabricated stair system, which consists of steps, strings and system fasteners. The steps are connected with the strings by system fasteners on both sides. Handrail and barrier can be part of the stair system, but they are not necessary for the load-bearing capacity of the stair.

The steps, the landing, the strings, the handrail and the posts are made of solid wood, the balusters are made of steel or solid wood and the system fasteners are made of steel.

The product description is given in Annex A. The material values, dimensions and tolerances of the components of the stair not indicated in the annexes shall correspond to the values laid down in the technical documentation<sup>1</sup>.

### 2 Specification of the intended use in accordance with the applicable European Assessment Document

The performances given in Section 3 are only valid if the stair is used in compliance with the specifications and conditions given in Annex B.

The verification and assessment methods on which this European Technical Assessment is based lead to the assumption of a working life of the stair of at least 50 years. The indications given on the working life cannot be interpreted as a guarantee given by the producer, but are to be regarded only as a means for choosing the right products in relation to the expected economically reasonable working life of the works.

<sup>1</sup> The technical documentation comprises all information of the manufacturer necessary for the production, installation and maintenance of the stair; these are in particular the structural analysis, design drawings and the manufacturer's installation instructions. The part to be treated confidentially is deposited with Deutsches Institut für Bautechnik and, as far as this is relevant to the tasks of the approved bodies involved in the procedure of attestation of the AVCP-System, shall be handed over to the approved body.

### 3 Performance of the product and references to the methods used for its assessment

#### 3.1 Mechanical resistance and stability (BWR 1)

Essential characteristic	Performance
Load-bearing capacity of stair	See Annex C2
Load-bearing capacity of fixings	See technical documentation of this European Technical Assessment
Load/displacement behaviour	See Annex C2
Vibration behaviour	First natural frequency: $f_1 \geq 5$ Hz (inclusive a single mass of 100 kg) Deflection under a single load $F = 1$ kN: $w \leq 5$ mm
Prevention of progressive collapse	Failure of individual components of the stair does not lead to a progressive collapse of the complete stair
Residual load-bearing capacity	Local material failure does not lead to an abrupt total loss of load-bearing capacity of the stair.
Long-term behaviour	Load-bearing capacity are ensured under an appropriate use and maintenance over the indicated working life
Resistance to earthquakes	No performance assessed
Durability against physical, chemical and biological agents	Adequate durability for the intended use under an appropriate use and maintenance

#### 3.2 Safety in case of fire (BWR 2)

Essential characteristic	Performance
Reaction to fire	See Annex A6
Fire resistance	No performance assessed

#### 3.3 Hygiene, health and the environment (BWR 3)

Essential characteristic	Performance
Release of formaldehyde	Wood adhesive does not contain formaldehyde
Release of pentachlorophenol	No pentachlorophenol treated materials are used
Radioactive emission	Not relevant

### 3.4 Safety in use (BWR 4)

Essential characteristic	Performance
Geometry	See Annex C1
Slipperiness	No performance assessed
Equipment of the stair for a safe use	Handrail and barrier can be part of the stair system (see Annex A4 and A5). If vertical balusters, arranged between step and handrail, are used as fill-in elements, climb ability for infants will not be supported Tactility and visibility: No performance assessed
Safe breakage of components	No brittle failure of individual stair components made of wood or steel ESG-H: type C according to EN 12600:2002-11 VSG: type B according to EN 12600:2002-11
Impact resistance	Verified for filling elements made of glass up to a pendulum fall height of twin tyres (weight 50 kg) of 450 mm (Type I and Type III) and 350 mm (Type II) Pendulum tests: test assembly according to EN 12600:2002-11 test performance according to TRAV <sup>2</sup>

## 4 Assessment and verification of constancy of performance (AVCP) system applied, with reference to its legal base

In accordance with the European Assessment Document EAD No. 340006-00-0506 the applicable European legal act is: 1999/89/EC

The System to be applied is: 2+

In addition, with regard to reaction to fire for products covered by the European Assessment Document EAD No. 340006-00-0506 the applicable European legal act is: 2001/596/EC

The System to be applied is: 4

<sup>2</sup>

TRAV: Technical rules for glazings used as barrier against falling down, Version January 2003  
(Technische Regeln für die Verwendung von absturzsichernden Verglasungen, Fassung Januar 2003)

**5 Technical details necessary for the implementation of the AVCP system, as provided for in the applicable European Assessment Document**

Technical details necessary for the implementation of the AVCP system are laid down in the control plan deposited at Deutsches Institut für Bautechnik.

Issued in Berlin on 22 January 2020 Deutsches Institut für Bautechnik

BD Dipl.-Ing. Andreas Kummerow  
Head of Department

*beglaubigt:*  
Stiller

### Types of construction

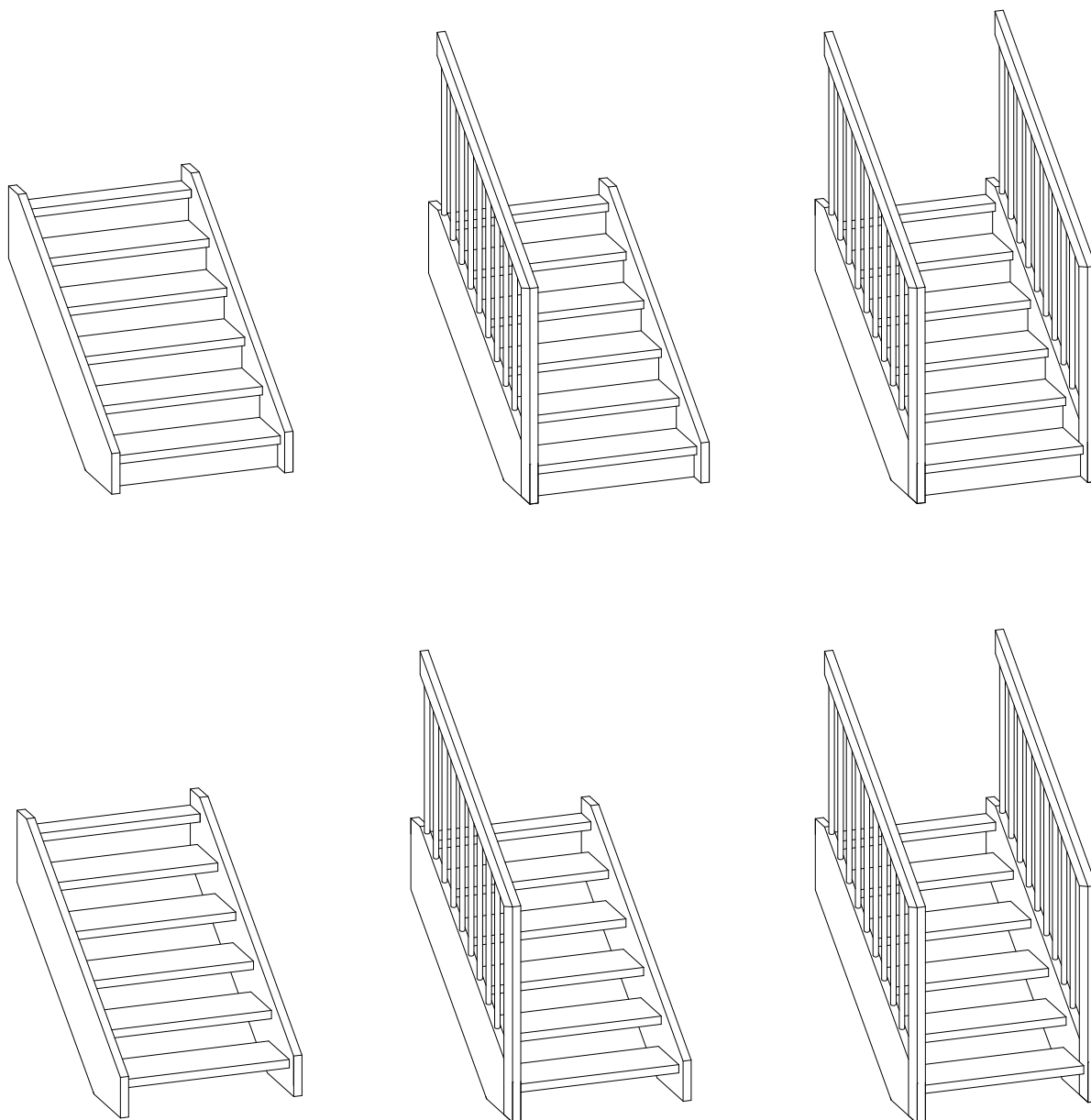

**String stair system Treppenmeister**

Product (types of construction)

**Annex A1**

### Types of plan

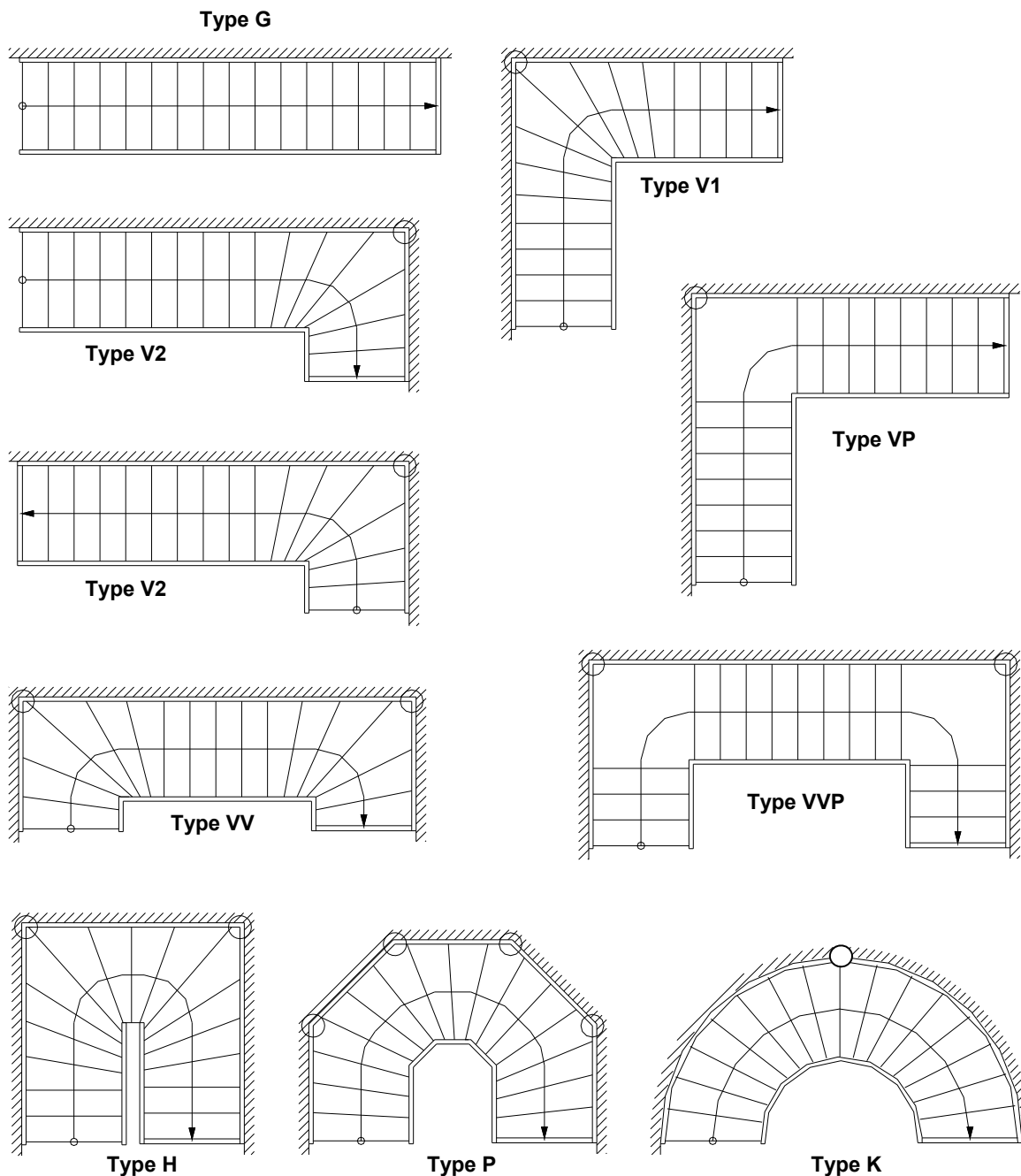

○ Support for vertical loads

maximum number of rises and horizontal fixings to the wall according to the technical documentation

### String stair system Treppenmeister

Product (types of plan)

**Annex A2**



### Barrier constructions (posts)

Post at bottom and post at the top

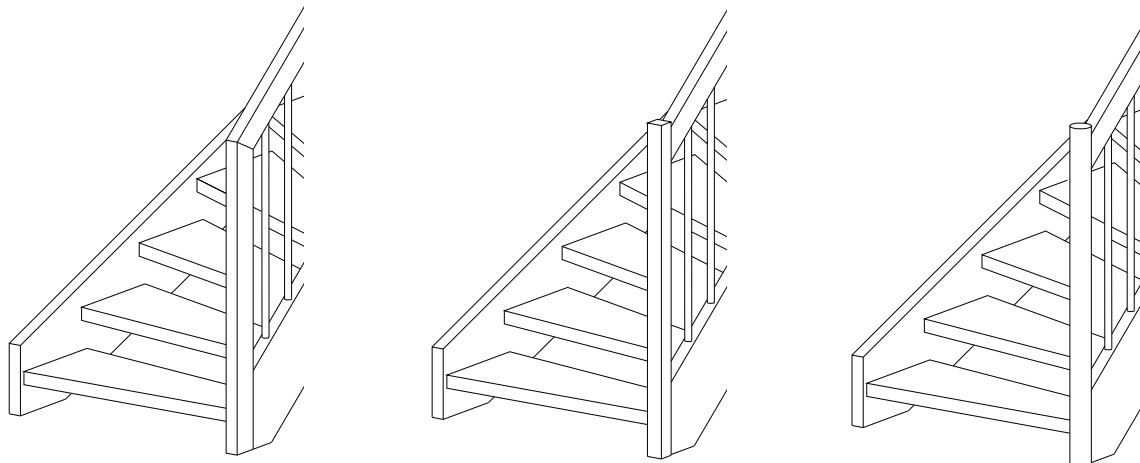

Middle post

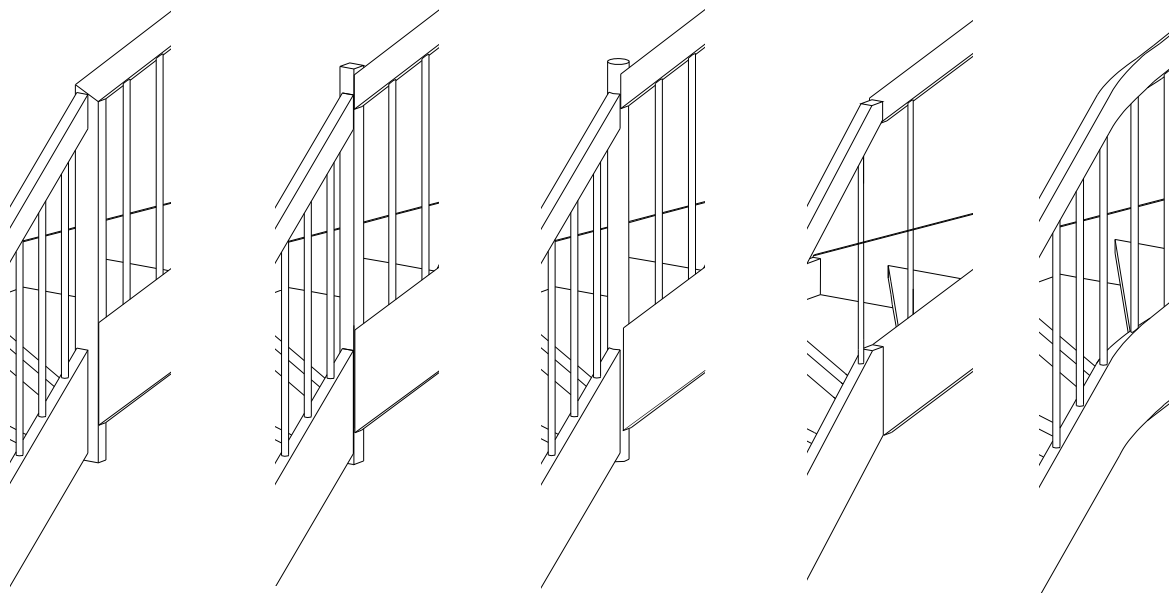

More details according to the technical documentation

**String stair system Treppenmeister**

Barrier constructions (posts)

**Annex A3**

**Barrier constructions  
(Filling elements with dead load maximum of 0.23 kN/m)**

Standard barrier

Distance of  
balusters  
≤ 130 mm

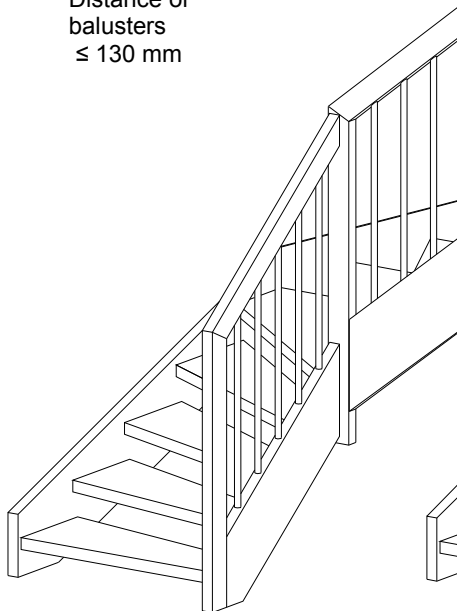

Railing barrier

Distance of  
balusters  
≤ 3 steps  
(500-800 mm)

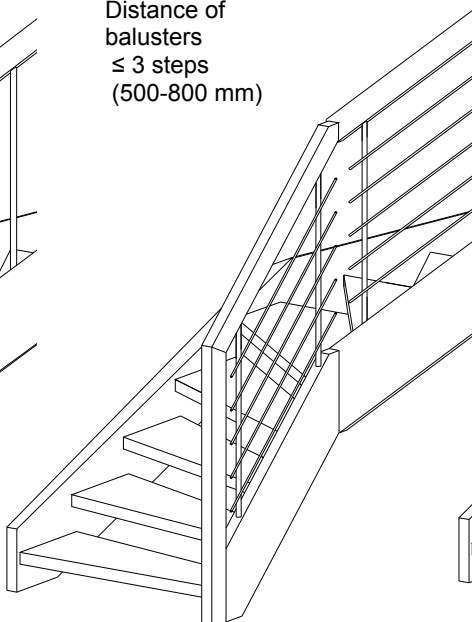

Glass barrier  
Type I

no balusters

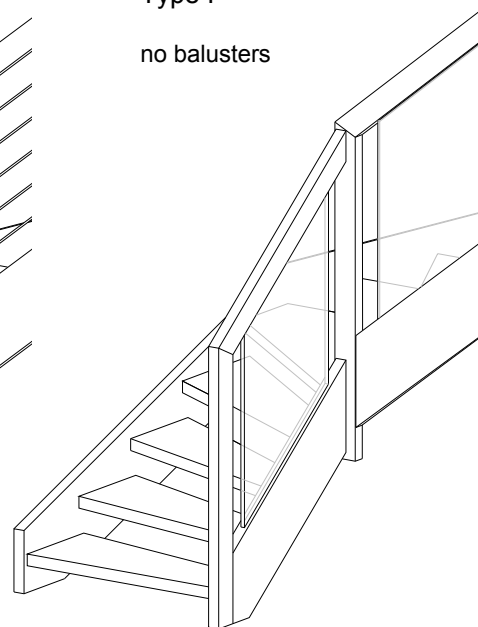

Glass barrier  
Type II

Distance of  
balusters  
≤ 3 steps  
(500-800 mm)

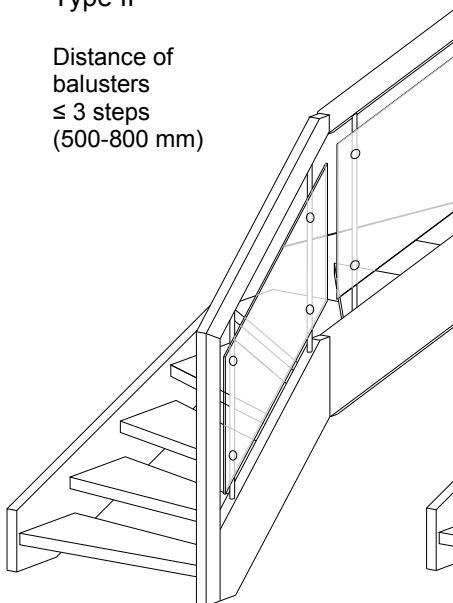

Glass barrier  
Type III

no balusters

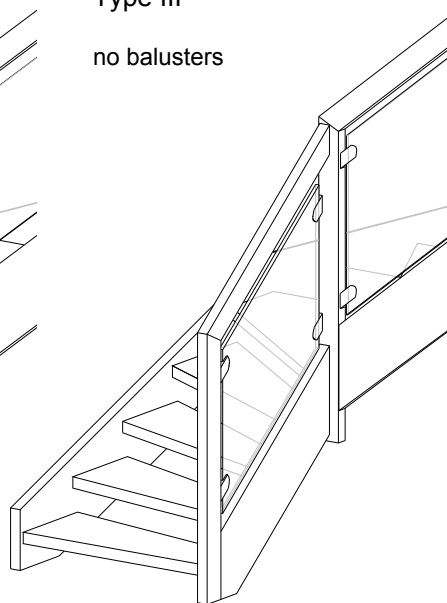

Glass barrier  
Type III

no balusters

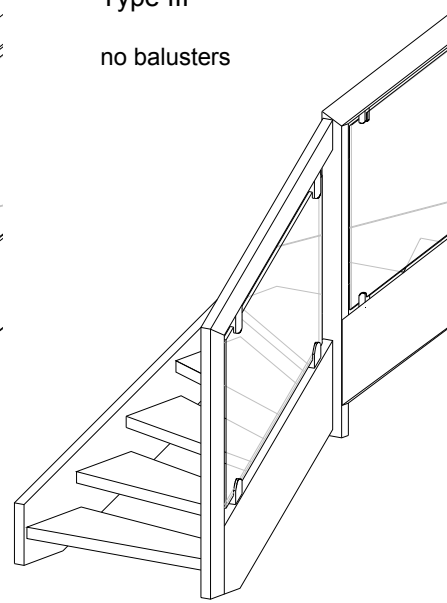

More details according to the technical documentation

**String stair system Treppenmeister**

Barrier constructions (fillings)

**Annex A4**

**Step-string-joint**

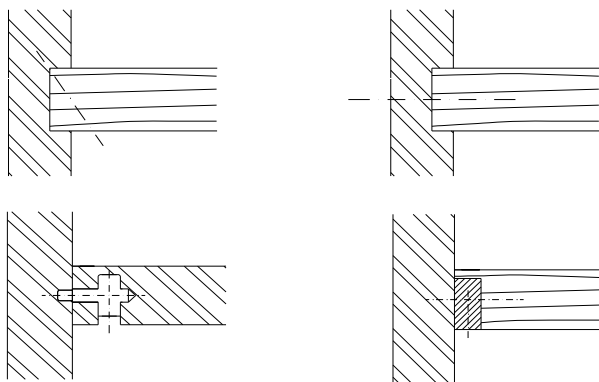

**String-corner-joint**

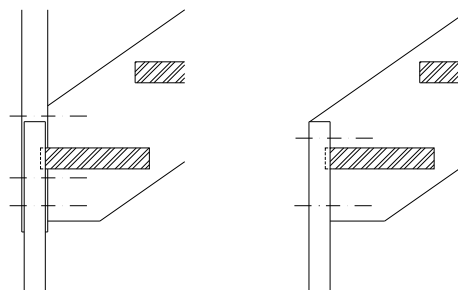

**Corner-support of strings**

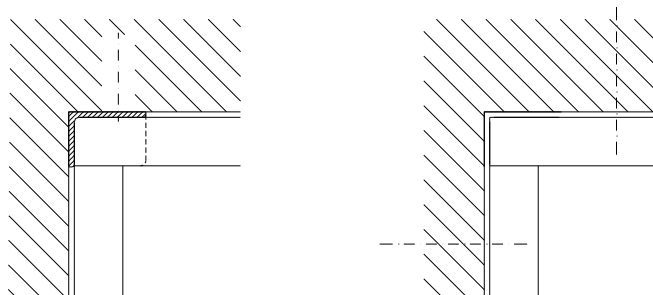

**Post-handrail-joint**

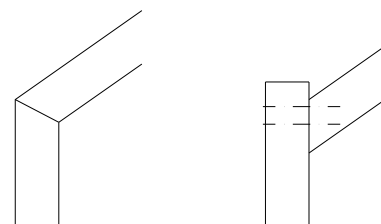

**String joint at the top**

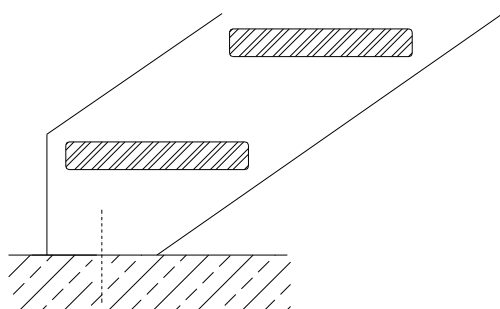

**String joint at bottom**

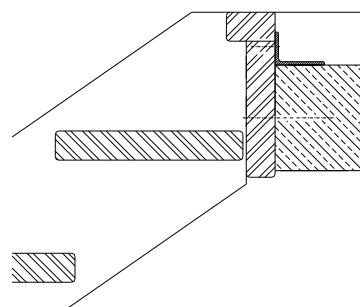

Relationship of joints to the wood species and types of plan and more details see technical documentation

**String stair system Treppenmeister**

Step-string-joint, String-corner-joint,  
Corner-support of strings, Post-handrail-joint  
String joint at the top, String joint at bottom

**Annex A5**

**Table 1: Minimum dimensions of components of stair and reaction to fire**

Component of stair		Material <sup>1)</sup>	Dimension		Value	Reaction to fire
Step		Solid wood <sub>2) 3) 4)</sub>	Thickness	[mm]	44 (48) <sup>10)</sup>	D-s2, d0
String	String at the wall	Solid wood <sub>2) 3) 4)</sub>	Width x height	[mm]	44 x 240...340 <sup>5)</sup>	D-s2, d0
	Wall-free string	Solid wood <sub>2) 3) 4)</sub>	Width x height	[mm]	44 x 240...340 <sup>5)</sup>	
Post	At bottom, at the top	Solid wood <sup>2)</sup>	Width x height	[mm]	44 x 70, 55 x 55 <sup>5)</sup>	D-s2, d0
	Middle post (only glass barrier Type I)	Solid wood <sup>2)</sup>	Width x height	[mm]	55 x 55	
Handrail		Solid wood <sup>2)</sup>	Width x height	[mm]	44 x 70 <sup>6)</sup>	D-s2, d0
Baluster		Solid wood <sup>2)</sup>	Diameter	[mm]	29	D-s2, d0
		Steel	Diameter	[mm]	16 (21,3) <sup>7)</sup>	A1
Barrier fillings Type I		Glass ESG-H	Thickness	[mm]	8	A1
Barrier fillings Type II and Type III		Glass ESG-H	Thickness	[mm]	8	A1
		Glass VSG <sup>8)</sup>	Thickness	[mm]	2 x 4 mm <sup>8)</sup>	no performance assessed
Angle joints, wall ties, system fastener		Steel	Diameter	[mm]	- <sup>9)</sup>	A1

<sup>1)</sup> Characteristic values of material according to technical documentation

<sup>2)</sup> Only wood of wood species 1:

Amazakoué, Bangkirai, Bongossi, Beech, Oak, Ash, Iroko/Kambala, Merbau, Wengé, Zebrano

<sup>3)</sup> Only wood of wood species 2:

Maple, Afzelia/Doussié, Acacia/Robinia, Birch, Bubinga, Cherry tree, Nut tree, Elm, Sapelli, Teak, Dibetou, Hevea

<sup>4)</sup> Only wood of wood species 3: Pine

<sup>5)</sup> Depending on the width of the stair (800...1200 mm), the number of rises, wood species and type of plan according to technical documentation,

<sup>6)</sup> Depending on type of plan and number of rises according to technical documentation, differing sections see Table 2

<sup>7)</sup> Value in brackets for railing barrier

<sup>8)</sup> VSG consisting of 2 x 4 mm ESG and 1.52 mm PVB-foil

<sup>9)</sup> According to technical documentation

<sup>10)</sup> Value in brackets for width of the stair > 1000 mm and ≤ 1200 mm

**String stair system Treppenmeister**

Minimum dimensions of components of the stair and reaction to fire

**Annex A6**

**Table 2: Differing minimum dimension of sections of posts and handrails**

Type of plan	Component	Barrier type	Dimension width x height in mm <sup>1)</sup>
G	post bottom and top	Glass barrier Type I	100 x 44
G	handrail	Standard barrier	44 x 70 and 70 x 44
		Railing- and Glass barrier Type II and III	44 x 70 and 70...110 x 44
		Glass barrier Type I	65...170 x 44
VVP	handrail	Glass barrier Type I	44 x 70 and 60...80 x 44
VP	post bottom and top	Glass barrier Type I	55 x 55 and 90 x 55
VP	handrail	Glass barrier Type I	44 x 70 and 60...90 x 44
V2	post bottom and top	Glass barrier Type I	55 x 55 and 90 x 55
V2	handrail	Railing- and Glass barrier Type II and III	44 x 70 and 70 x 44
		Glass barrier Type I	65...110 x 44
V1	post bottom and top	Glass barrier type I	55 x 55 and 90 x 55
V1	handrail	Glass barrier Type I	44 x 70 and 60...100 x 44
VV	handrail	Glass barrier Type I	65...100 x 44
H	handrail	Glass barrier Type I	44 x 70 and 70 x 44
P	handrail	Glass barrier Type I	44 x 70 and 70 x44

<sup>1)</sup> from...to data and alternatives depend on number of rises and the horizontal support at the height of the ceiling edge, detailed values according to technical documentation

**String stair system Treppenmeister**

Minimum dimension of sections of posts and handrails

**Annex A7**

## Specification of intended use (Part 1)

### Intended use:

- European Technical Assessment applies for a construction system.
- For the specific case of use the corresponding type of stair is manufactured within the context of the values defined in this European Technical Assessment.
- Values of this ETA apply to all types of stairs, the real dimensions follow in accordance with the relevant case of use.

### Stair subject to:

- Static and quasi static loads

### Use conditions:

- Indoor stair
- Air temperatures between +5 °C and +30 °C
- Relative air humidity between 30% and 70%

### Design:

- Design of the stair according to the annexes and the technical documentation of this European Technical Assessment.
- Fastening of the stair to the construction works according to the annexes and the technical documentation of this Technical European Assessment.
- Verification of the transmission of loads to the construction works by the civil engineer responsible for the construction works.
- Load bearing capacity at ultimate limit state:

$$q_k \cdot \gamma_Q \leq q_{RK} / \gamma_M$$

$$Q_k \cdot \gamma_Q \leq Q_{RK} / \gamma_M$$

$$h_k \cdot \gamma_Q \cdot \psi_0 \leq h_{RK} / \gamma_M$$

with

$q_{RK}, Q_{RK}, h_{RK}$ : characteristic values of resistance; see Table 4

$\gamma_M$ : recommended material partial safety factor; see Table 4

$q_k, Q_k, h_k$ : characteristic values of imposed loads according to EN 1991-1-1:2002 + AC:2009

$\gamma_Q = 1.5$ : recommended partial safety factor, in absence of other national regulations

$\psi_0 = 0.7$ : recommended combination factor, in absence of other national regulations

- Maximum characteristic values of imposed loads under consideration of the partial factors mentioned above; see Table 6

**String stair system Treppenmeister**

Specification of intended use (Part 1)

**Annex B1**

### Specification of intended use (Part 2)

**Installation:**

- Installation by personal appropriately trained and authorized by the manufacturer by means of the technical documentation of this European Technical Assessment
- Installation only in the way as specified in the technical documentation of this European Technical Assessment
- Installation of timber components when moisture content of timber components is  $8 \pm 2 \%$
- Sufficient support of the stair when assembling
- Installation of stair components without imposed deformations
- Installation of stair components without significant defects and cracks
- Replacing of stair components, which begin tearing when assembling
- Bolted connection are protected such that they will not be loosened by vibrations

**Indication of the manufacturer:**

- Ensure that all persons involved will be appropriately informed about the specific conditions according to sections 1 and 2 (including the annexes to which reference is being made as well as the not confidential parts of the technical documentation deposited to this European Technical Assessment)
- Packaging of timber components such that the wood moisture is  $8 \pm 2 \%$  during transport and storage
- Instructions for use should provide information as to use, maintenance and repair of the stair. Including the information of avoidance of moisture penetration of the timber components

**String stair system Treppenmeister**

Specification of intended use (Part 2)

**Annex B2**

**Table 3: Geometry**

Designation			Dimension	
			Minimum	Maximum
Going	step on walking line <sup>1)</sup>	[mm]	210	370 <sup>2)</sup>
	tapered step	[mm]	60 <sup>2), 3)</sup>	600 <sup>2), 4)</sup>
Rise of the stairs <sup>1)</sup>		[mm]	140 <sup>2)</sup>	210
Pitch of the walking line <sup>1)</sup>		[°]	21	45
Overlap of steps	wall side	[mm]	30	- <sup>5)</sup>
	wall-free side	[mm]	30	- <sup>5)</sup>
Number of rises			3	20
Openings	between barrier and other parts of the stair	[mm]	0	0
	between stairs and wall	[mm]	- <sup>5)</sup>	50
	between consecutive steps	[mm]	- <sup>5)</sup>	166
	between balusters	[mm]	40	130 (800) <sup>6)</sup>
Clear width of stairs		[mm]	500	1200
Minimum headroom		[mm]	- <sup>5)</sup>	
Length of the flight		[mm]	- <sup>5)</sup>	4940 (5980) <sup>7)</sup>
Thickness of steps		[mm]	44	- <sup>5)</sup>
Height of the barrier / handrail		[mm]	900	1000
Handrail	width	[mm]	44	170
	height	[mm]	44	110
	clear distance to adjacent components	[mm]	50	- <sup>5)</sup>

- 1) Values are constant within one flight
- 2) Tolerance between nominal value and actual value = ± 5 mm
- 3) Wall-free side of tapered step
- 4) Wall side of tapered step
- 5) Not relevant
- 6) See also Annex A4
- 7) Value in brackets for stairs with landing

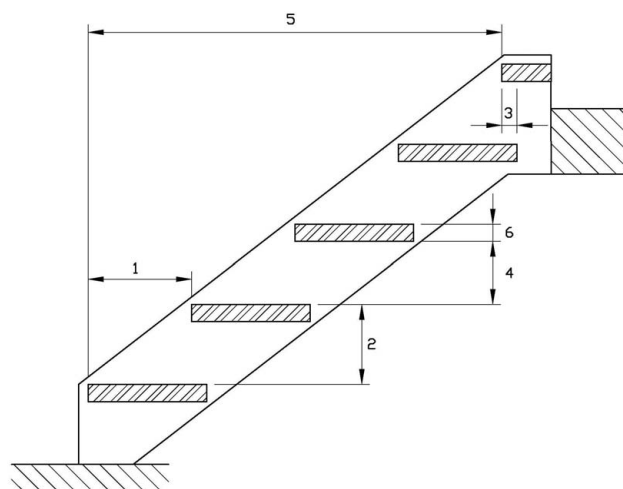

- 1** Going
- 2** Rise
- 3** Overlap
- 4** Opening between consecutive steps
- 5** Length of the flight
- 6** Thickness of steps

**String stair system Treppenmeister**

Geometry of the stair

**Annex C1**



**Table 4: Load-bearing capacity - Characteristic values of resistance**

Component	Type of loading	Characteristic values of resistance			$\gamma_M$
Flight	vertical variable uniformly distributed load	$q_{RK}$	[kN/m <sup>2</sup> ]	6.8	1.5 <sup>1)</sup>
	vertical variable single load	$Q_{RK}$	[kN]	4.5	
	horizontal variable uniformly distributed load on barrier	$h_{RK}$	[kN/m]	0.8	
Joint at the top and at bottom	vertical variable uniformly distributed load	$q_{RK}$	[kN/m <sup>2</sup> ]	5.0	1.1 <sup>2)</sup>
	vertical variable single load	$Q_{RK}$	[kN]	3.3	
	horizontal variable uniformly distributed load on barrier	$h_{RK}$	[kN/m]	0.6	

<sup>1)</sup> Recommended partial safety factor (wood decisive), in absence of other national regulations

<sup>2)</sup> Recommended partial safety factor (steel decisive), in absence of other national regulations

**Table 5: Deflections under loading**

Deflection of the flight under uniformly distributed load			
uniformly distributed load	$q_k$	[kN/m <sup>2</sup> ]	3.0
length of the median line of the flight	L	[mm]	4940 (5980) <sup>1)</sup>
deflection under load $F_S$ related to the median line of the flight	w	[-]	≤ L/200
Deflection of the step under single point load			
single load	$Q_k$	[kN]	2.0
clear width of the stair	L	[mm]	1200
deflection under load $F_S$ related to the clear width of the stair	w	[-]	≤ L/200

<sup>1)</sup> Value in brackets for stairs with landing

**Table 6: Imposed loads**

Type of loading	Imposed loads		
vertical variable uniformly distributed load	q	[kN/m <sup>2</sup> ]	3.0
vertical variable single load	Q	[kN]	2.0
horizontal variable uniformly distributed load on barrier	h	[kN/m]	0.5

**String stair system Treppenmeister**

Load-bearing capacity - Characteristic values of resistance,  
Deflections under loading,  
Imposed loads

**Annex C2**