

Approval body for construction products
and types of construction

Bautechnisches Prüfamt

An institution established by the Federal and
Laender Governments



European Technical Assessment

ETA-17/0060
of 23 July 2020

English translation prepared by DIBt - Original version in German language

General Part

Technical Assessment Body issuing the
European Technical Assessment:

Deutsches Institut für Bautechnik

Trade name of the construction product

Würth-Kabelbox

Product family
to which the construction product belongs

Construction product for use in penetration seals - cable
box

Manufacturer

Adolf Würth GmbH & Co. KG
Reinhold-Würth-Straße 12-17
74653 Künzelsau
DEUTSCHLAND

Manufacturing plant

Herstellwerk 7

This European Technical Assessment
contains

19 pages including 15 annexes which form an integral
part of this assessment

This European Technical Assessment is
issued in accordance with Regulation (EU)
No 305/2011, on the basis of

EAD 350454-00-1104

The European Technical Assessment is issued by the Technical Assessment Body in its official language. Translations of this European Technical Assessment in other languages shall fully correspond to the original issued document and shall be identified as such.

Communication of this European Technical Assessment, including transmission by electronic means, shall be in full. However, partial reproduction may only be made with the written consent of the issuing Technical Assessment Body. Any partial reproduction shall be identified as such.

This European Technical Assessment may be withdrawn by the issuing Technical Assessment Body, in particular pursuant to information by the Commission in accordance with Article 25(3) of Regulation (EU) No 305/2011.

Specific part

1 Technical description of the product

The construction product "Würth-Kabelbox" consists of a moulded part made of sheet steel and fire-protective inlays made of an intumescent material, which expands under heat exposure.

The construction product is manufactured in different geometrical forms and dimensions (see Annexes 3 and 4)

A detailed technical description of the fire safety related performance criteria (e. g. dimensions) and the construction product are given in Section 3.2 and Annexes 1 to 4.

Detailed information on the construction product's components is deposited with DIBt.

NOTE:

The characteristics listed are suitable both for identifying the construction product as well as for performing the manufacturer's factory production control.

2 Specification of the intended use in accordance with the applicable European Assessment Document

The construction product "Würth-Kabelbox" is used as a component in cable penetration seals.

Cable penetration seals are used to seal openings in fire-resistant walls or floors, which are penetrated by cables. Their aim is to preserve the walls' or floors' resistance to fire in the area of the penetrations.

This ETA has served to verify the resistance to fire of cable penetration seals containing one or several "Würth-Kabelbox" construction products. The cable penetration seals were also sealed on both sides with a "Würth-Kabelbox" seal (plug). These plugs consisted of a foaming material laminated with aluminium foil, a silicone or an in-situ foam for sealing the remaining joints of the "Würth-Kabelbox" and mortar or gypsum for sealing the gap between the "Würth-Kabelbox" and the edge of the surrounding building element.

The construction product "Würth-Kabelbox" may be used for cable penetration seals of use category Z₁ (intended for use under internal conditions with high humidity, excluding temperatures below 0 °C) provided that the other components of the cable penetration seal which are not covered by this ETA meet the durability requirements. The resistance to fire of the cable penetration seals shall be verified on a case-by case basis.

More detailed information and data on the verified cable penetration seals is given in Annexes 5 to 15.

The performances given in Section 3 apply exclusively to the cable penetration seals assessed as part of the ETA procedure (e.g. with respect to the design and arrangement of the cable penetration seal's components as well as the type and position of the services).

3 Performance of the product and references to the methods used for its assessment

3.1 Intended use: use in penetration seals

3.2 Safety in case of fire (BWR 2)

Essential characteristic	Performance
Reaction to fire "Blechgehäuse"	Class A1 according to the commission decision 96/603/EC (current version)
Reaction to fire "Palusolpaket"	Class E according to EN 13501-1
Reaction to fire "Intumeszierende Einlage"	Class E according to EN 13501-1
Reaction to fire "Rauchdichtung"	Class C-s2, d0 according to EN 13501-1
Resistance to fire of a cable penetration seal containing the product	The resistance to fire depends on the design and installation of the cable penetration seal and on the other components that make up the cable penetration seal. More details on the tested cable penetration seals and the related fire resistance classes are given in Annexes 1 to 15.

4 Assessment and verification of constancy of performance (AVCP) system applied, with reference to its legal base

In accordance with European Assessment Document (EAD) no. 350454-00-1104, the following legal base shall apply: 1999/454/EC.
The system to be applied is: system 1.

5 Technical details necessary for the implementation of the AVCP system, as provided for in the applicable EAD

The technical details necessary for the implementation of the AVCP system are laid down in the control plan deposited with DIBt.

Issued in Berlin on 23 July 2020 by Deutsches Institut für Bautechnik

Maja Tiemann
Head of Department

beglaubigt:
Bisemeier

The factory manufactured construction products of the type "Würth-Kabelbox" consists of a sheet steel casing, an inlay and a smoke sealing. They are used for cable penetration seals.

Properties and performance criteria of the components of the construction product "Würth-Kabelbox"

Component	Description
"Steel sheet casing" The material specifications are deposited at the DIBt.	Sheet steel Dimensions according to annexes 3 and 4 Classification of the fire behavior: Class A1 according to the commission decision 96/603/EC (current version)
"Palusol packet" The material specifications are deposited at the DIBt.	Hermetically sealed packet made of polystyrene thickness ca. 1,5 mm, inside assembled stripes of fire protection boards
"Intumescent inlay" The material specifications are deposited at the DIBt.	Graphit-Stripes
"smoke sealing" The material specifications are deposited at the DIBt.	Aluminium laminated foam Reaction to fire according to EN 13501-1: Class C-s2, d0

The properties listed can be used both for the identification of the construction product and for the implementation of the factory production control of the manufacturer.
Implementation details for the factory production control are included in the inspection plan.

Description of the additional ingredients of the tested cable penetration seals

Sealing the gaps and joints on the surface of the cable box	Silikon vom Typ "KÖDISIL HAC" Reaction to fire according to EN 13501-1: Class E
Sealing of residual joint between cable box and soffit	Gypsum or mortar Classification of the fire behavior: Class A1 according to the commission decision 96/603/EC (current version)
Sealing of residual joint between cable box and soffit The material specifications are deposited at the DIBt.	In-situ foam "PURELOGIC EASY" Reaction to fire according to EN 13501-1: Class E

Würth-Kabelbox

Description of the construction products, properties and performances

Annex 1

Performances of cable penetration seals, tested with the construction product "Würth-Kabelbox"				
	Essential requirement	Test method	Construction of the sample	Performance
1	Resistance to fire	EN 1366-3	Penetration seal used in a 100 mm thick flexible wall; design and layout of the penetration seal acc. to annex 5	s. Annex 5
2	Resistance to fire	EN 1366-3	Penetration seal used in a 150 mm thick rigid floor; design and layout of the penetration seal acc. to annex 6	s. Annex 6
3	Resistance to fire	EN 1366-3	Penetration seal used in a 100 mm thick rigid wall; design and layout of the penetration seal acc. to annex 7	s. Annex 7
4	Resistance to fire	EN 1366-3	Penetration seal used in a 100 mm thick rigid wall; design and layout of the penetration seal acc. to annex 8	s. Annex 8
5	Resistance to fire	EN 1366-3	Penetration seal used in a 100 mm thick flexible wall; design and layout of the penetration seal acc. to annex 9	s. Annex 9
6	Resistance to fire	EN 1366-3	Penetration seal used in a 100 mm thick flexible wall; design and layout of the penetration seal acc. to annex 10	s. Annex 10
7	Resistance to fire	EN 1366-3	Penetration seal used in a 150 mm thick rigid floor; design and layout of the penetration seal acc. to annex 11	s. Annex 11
8	Resistance to fire	EN 1366-3	Penetration seal used in a 100 mm thick flexible wall; design and layout of the penetration seal acc. to annex 12	s. Annex 12
9	Resistance to fire	EN 1366-3	Penetration seal used in a 100 mm thick flexible wall; design and layout of the penetration seal acc. to annex 13	s. Annex 13
10	Resistance to fire	EN 1366-3	Penetration seal; design and layout of the penetration seal acc. to annex 14	s. Annex 14
11	Resistance to fire	EN 1366-3	Penetration seal used in a 150 mm thick rigid floor; design and layout of the penetration seal acc. to annex 15	s. Annex 15
<p>The tested/illustrated cable penetration seals are only examples for the use.</p> <p>The illustrations on annexes 3 till 15 are without guarantee for completeness.</p> <p>The use of the construction products "Würth-Kabelbox" in cable penetration seals shall be in accordance with national requirements for planning, design and execution and in accordance with the installation instruction of the manufacturer.</p>				
Würth-Kabelbox				Annex 2
Description of performances				

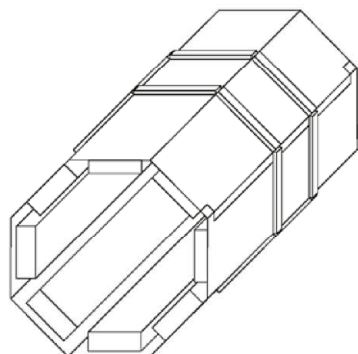

Type 1, 8-octagonal Cablebox

- diameter (parallel surface) 65 mm up to 260 mm
- diameter (opposite corners) mm up to 281 mm
- depth 270 mm

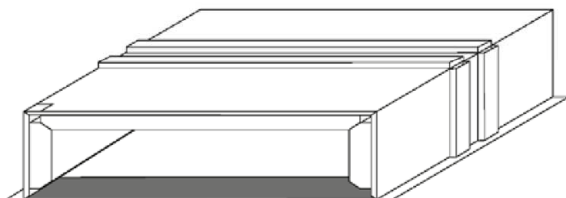

Type 2, threesided, for installation in floors with wall attachment and in walls with attachment to the ceiling, with intumescend strips on the front ends and a circumferential strip in the middle.

- breadth 120 mm up to 535 mm
- hight 30 mm up to 110 mm
- depth 270 mm

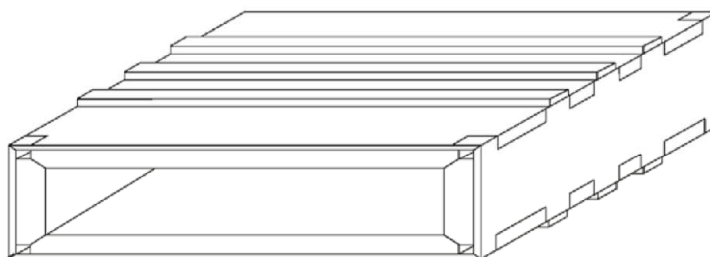

Type 3

- breadth 120 mm up to 640 mm
- hight 60 mm up to 110 mm
- depth 270 mm up to 350 mm

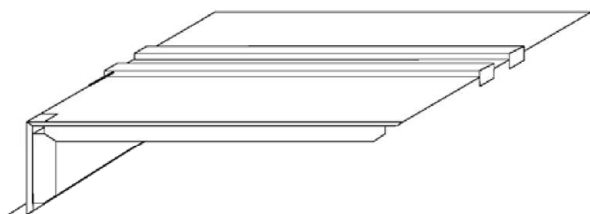

Type 4, extension for threesided cableboxes
- breadth 120 mm up to 535 mm
- hight 30 mm up to 110 mm
- depth 270 mm

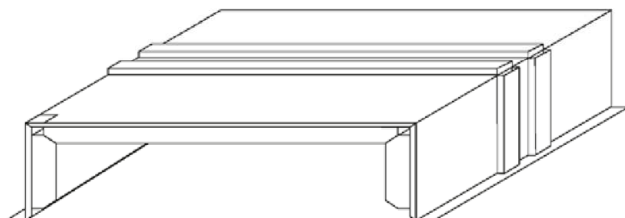

Type 5, threesided, for floor attachment
- breadth 120 mm up to 535 mm
- hight 30 mm up to 110 mm
- depth 240 mm, 270 mm or 350 mm

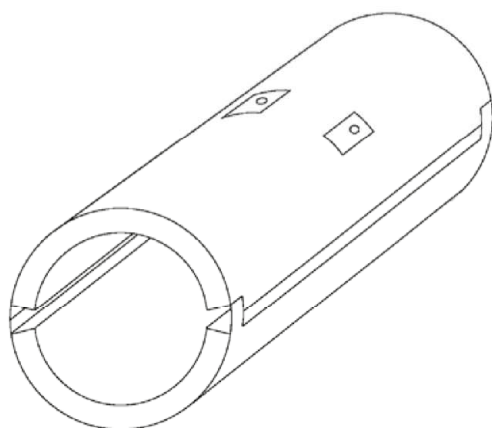

Type 6
- diameter 70 mm up to 250 mm
- depth 284 mm

Example of octagonal cablebox (type 1) in a flexible wall

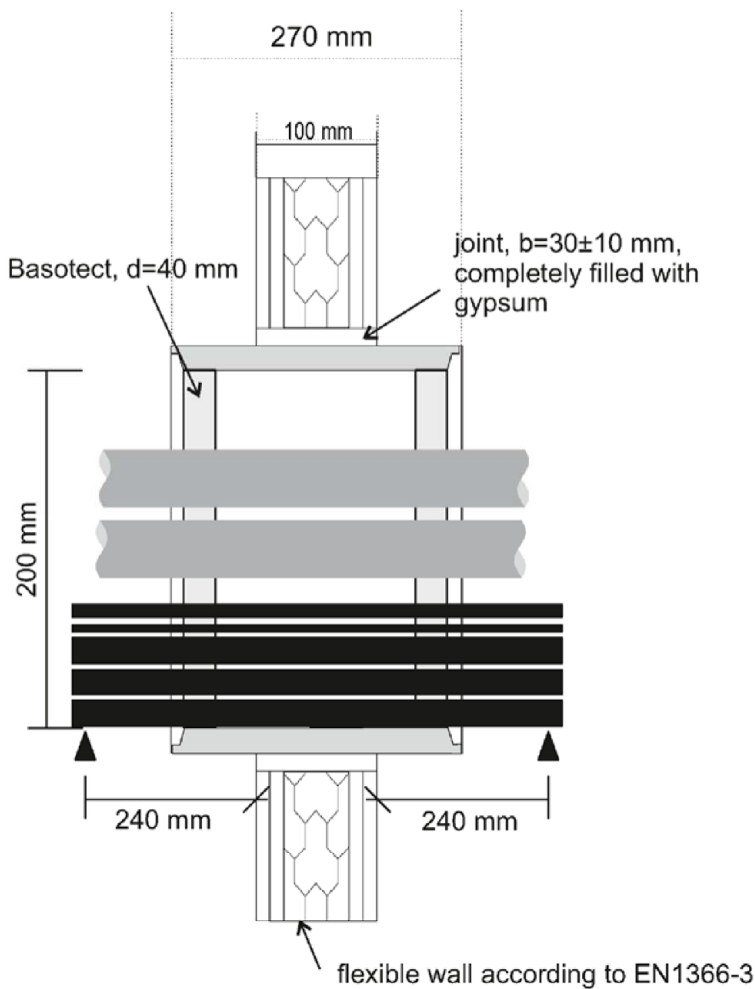
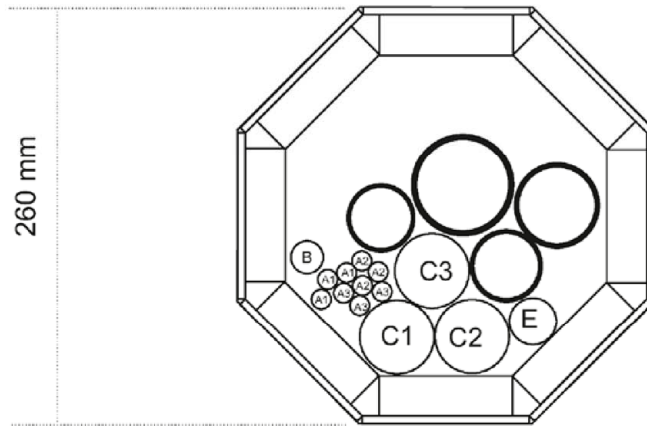

Cable configurations:

- cable according to EN1366-3:2009-07:

- 1xB-cable 1x95²
- 3xA1-cable 5x1,5²
- 3xA2-cable 5x1,5²
- 3xA3-cable 5x1,5²
- 1xC1-cable 4x95²
- 1xC2-cable 4x95²
- 1xC3-cable 4x95²
- 1xE-cable 1x185²

- polypropylene resp. polyethylene pipes:

- HTGL (PP) 50x1,8 mm
- Polokal NG 50x2 mm (PP),
- OHM PE-HD 32x3,0
- OHM PE-HD 50x4,6

Electronic copy of the ETA by DIBt: ETA-17/0060

Würth-Kabelbox

Example for the verification of the construction product "Würth-Kabelbox" as a part of cable penetration seal, with a fire resistance (integrity and thermal insulation) for more than 60 minutes - Structure of the test specimen; Installation in a flexible wall -

Annex 5

Example of round cablebox (type 6) in a rigid floor

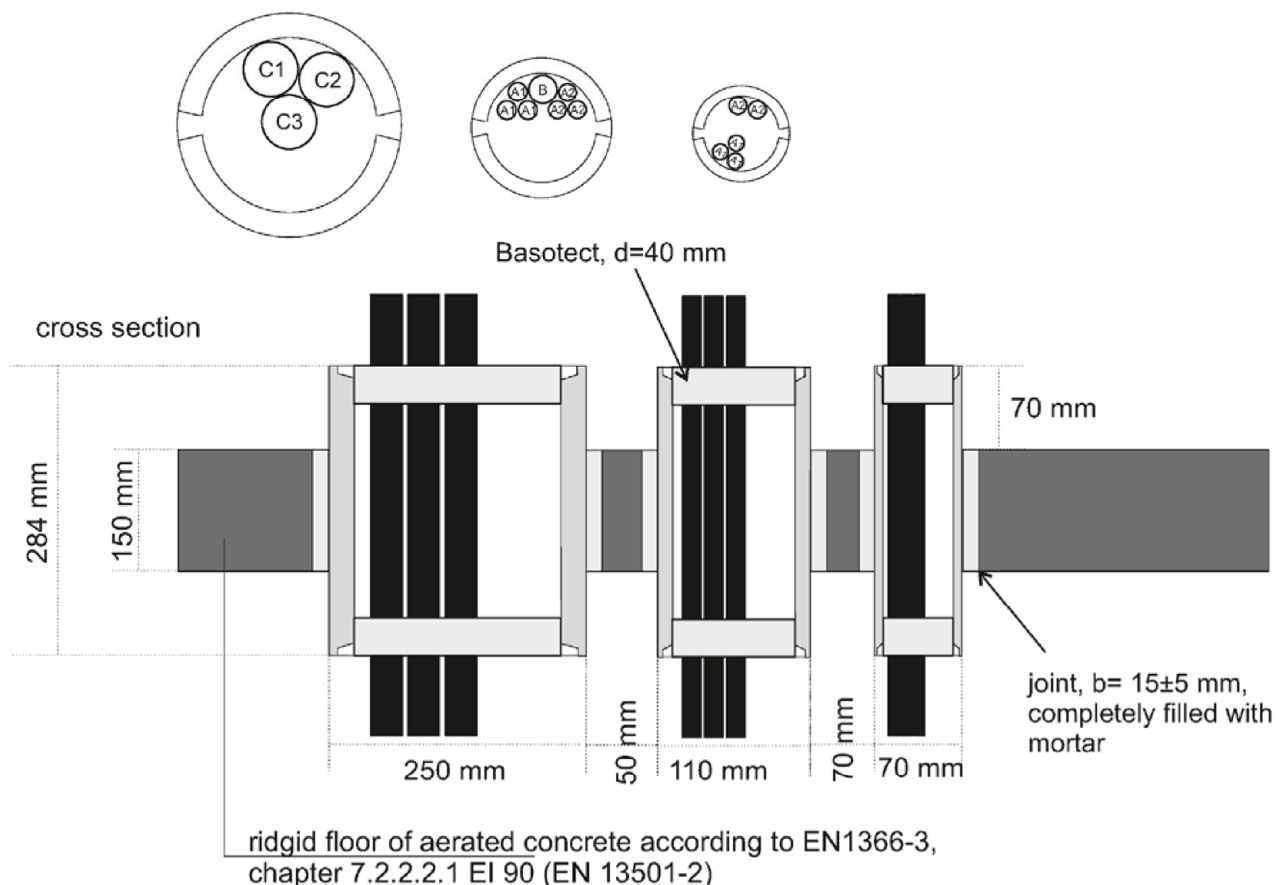

Cable configuration according to EN1366-3:2009-07

Ø 250 mm

1xC1-Cable 4x95²

1xC2-Cable 4x95²

1xC3-Cable 4x95²

Ø 110 mm

1xB-Cable 1x95²

3xA1-Cable 5x1,5²

3xA2-Cable 5x1,5²

Ø 70 mm

3xA1-Cable 5x1,5²

2xA2-Cable 5x1,5²

Example of threesided cablebox (type 2) in a rigid floor, with an attachment to an adjacent rigid wall

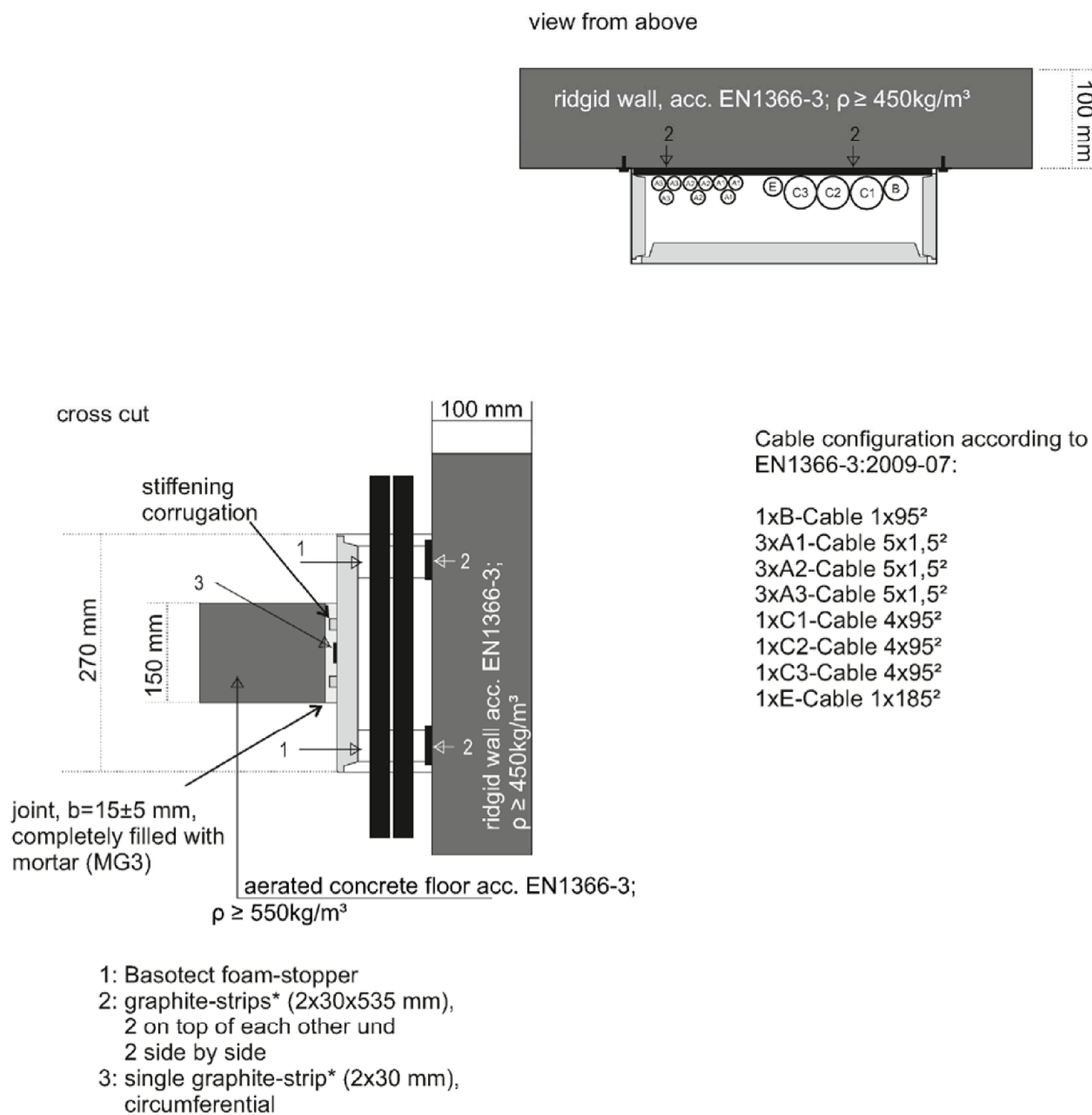

* the composite has been lodged at the DIBt

Würth-Kabelbox

Example for the verification of the construction product "Würth-Kabelbox" as a part of a cable penetration seal, with a fire resistance (integrity and thermal insulation) for more than 90 minutes - Structure of the test specimen; Installation in a rigid floor -

Annex 7

Example of threesided cablebox (type 2) in a rigid wall, with an attachment to an adjacent rigid ceiling

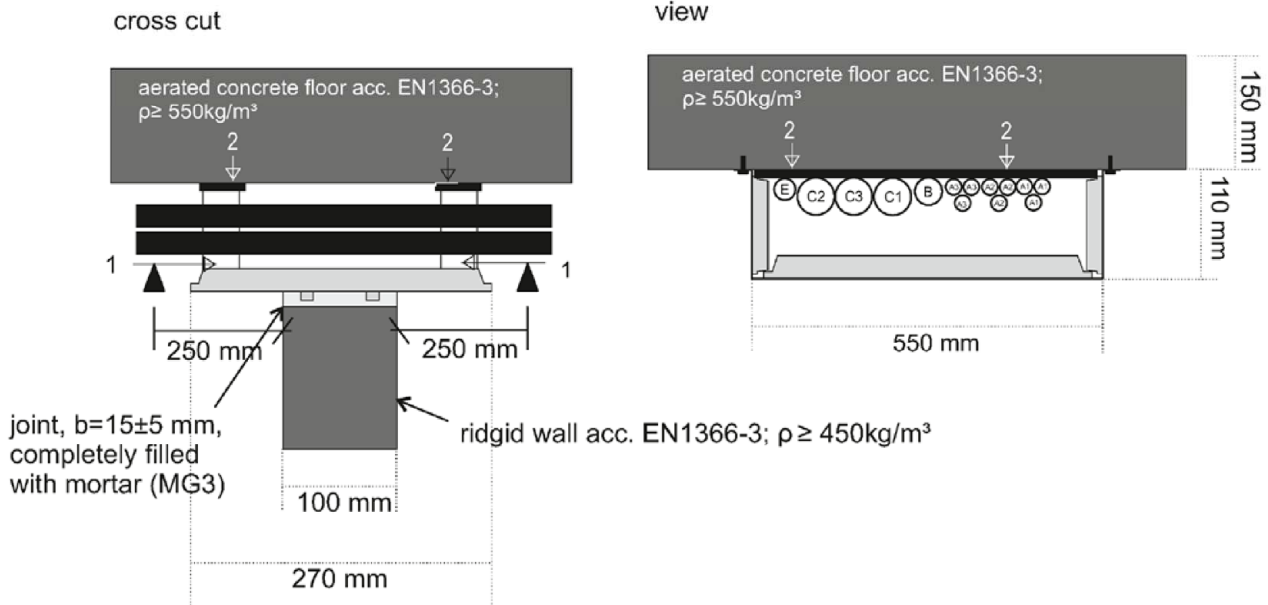

joint, $b=15\pm 5$ mm, completely filled with mortar (MG3)

rigid wall acc. EN1366-3; $\rho \geq 450\text{kg/m}^3$

- 1: Basotect foam-stoppers
- 2: graphite-strips* (2 mm x 30 mm x 535 mm), 2 on top of each other and 2 side by side

cable configuration according to EN1366-3:2009-07

- 1xB-Cable 1x95²
- 3xA1-Cable 5x1,5²
- 3xA2-Cable 5x1,5²
- 3xA3-Cable 5x1,5²
- 1xC1-Cable 4x95²
- 1xC2-Cable 4x95²
- 1xC3-Cable 4x95²
- 1xE-Cable 1x185²

* the composite has been lodged at the DIBt

Electronic copy of the ETA by DIBt: ETA-17/0060

Würth-Kabelbox	Annex 8
Example for the verification of the construction product "Würth-Kabelbox" as a part of a cable penetration seal, with a fire resistance (integrity and thermal insulation) for more than 120 minutes - Structure of the test specimen; Installation in a rigid wall -	

Example of rectangular cablebox (type3) in a flexible wall

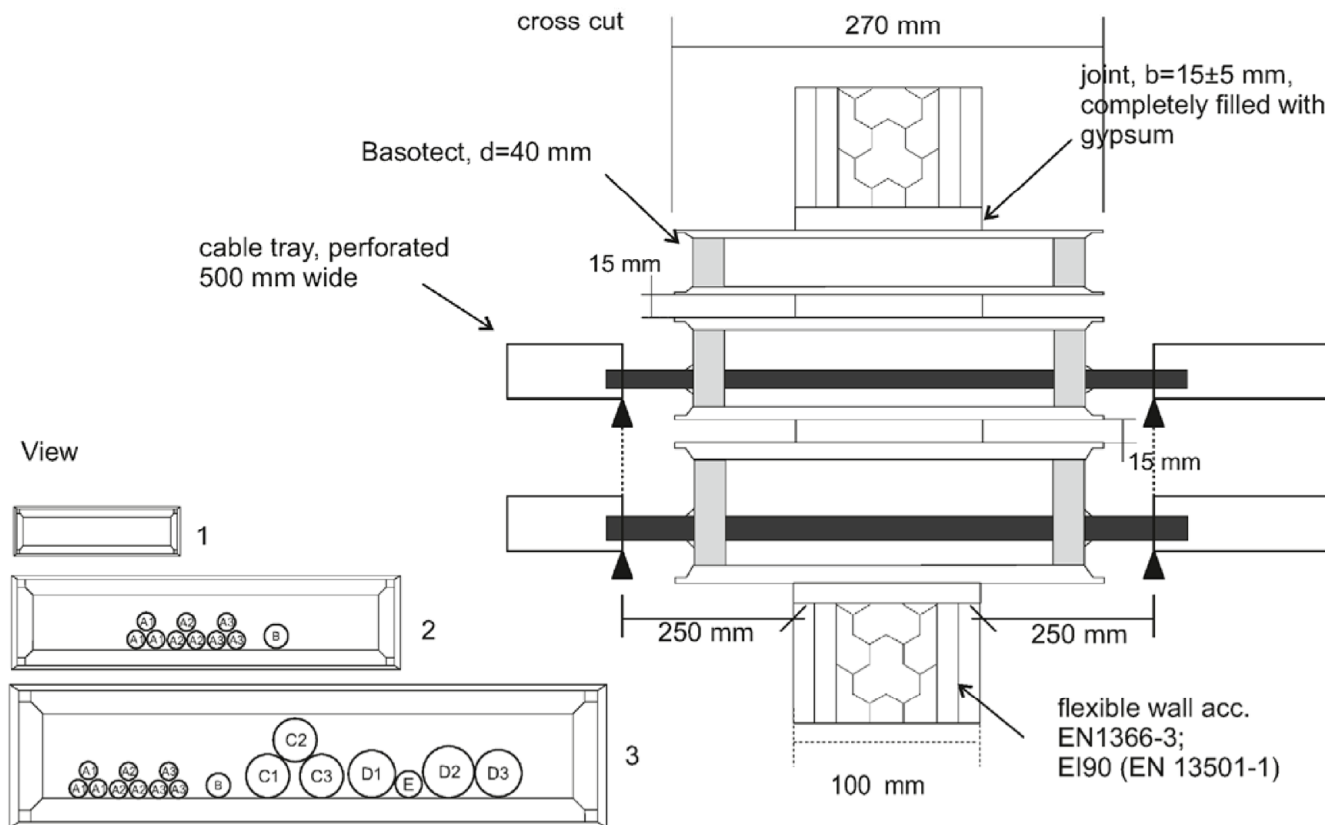

Cablebox	3	2	1
Dimensions	110 x 640 x 270 [mm]	90 x 380 x 270 [mm]	60 x 90 x 270 [mm]
Configuration	Cable configuration acc. to EN 1366-3:2009-07 1xB-cable 1x95 ² 3xA1-cable 5x1,5 ² 3xA2-cable 5x1,5 ² 3xA3-cable 5x1,5 ² 1xC1-cable 4x95 ² 1xC2-cable 4x95 ² 1xC3-cable 4x95 ² 1xE-cable 1x185 ² 1xD1-cable 4x185 ² 1xD2-cable 4x185 ² 1xD3-cable 4x185 ²	Cable configuration acc. to EN 1366-3:2009-07 1xB-cable 1x95 ² 3xA1-cable 5x1,5 ² 3xA2-cable 5x1,5 ² 3xA3-cable 5x1,5 ² 1xC1-cable 4x95 ² 1xC2-cable 4x95 ² 1xC3-cable 4x95 ²	blank

Würth-Kabelbox

Example for the verification of the construction product "Würth-Kabelbox" as a part of a cable penetration seal, with a fire resistance (integrity and thermal insulation) for more than 90 minutes - Structure of the test specimen; Installation in a flexible wall -

Annex 9

Example of threesided cablebox (type 5) with an adjacent extension module (type 4) in a flexible wall with an attachment to the floor

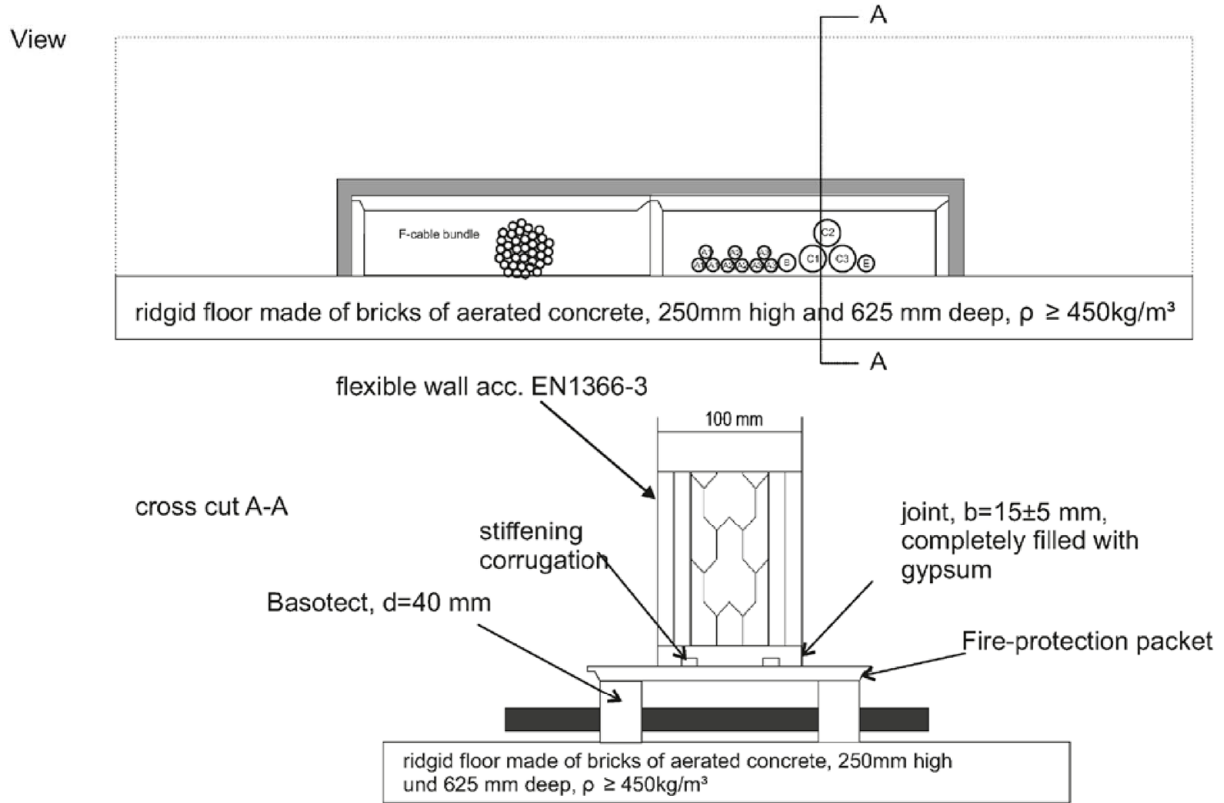

Type	Type 4 and 5	
Dimensions	110 x 535 x 270 [mm] three-sides + 110 x 535 x 270 [mm] two-sided	110 x 535 x 240 [mm] three-sides + 110 x 535 x 240 [mm] two-sided
Configuration	configuration with cable acc. EN1366-3:2009-07 1xB-cable 1x95 ² 3xA1-cable 5x1,5 ² 3xA2-cable 5x1,5 ² 3xA3-cable 5x1,5 ² 1xC1-cable 4x95 ² 1xC2-cable 4x95 ² 1xC3-cable 4x95 ² 1xE-cable 1x185 ² cable-bundle, Ø 10 cm consisting of 20 F-cable, Ø 21 mm	configuration with cable acc. EN1366-3:2009-07 1xB-cable 1x95 ² 3xA1-cable 5x1,5 ² 3xA2-cable 5x1,5 ² 3xA3-cable 5x1,5 ² 1xC1-cable 4x95 ² 1xC2-cable 4x95 ² 1xC3-cable 4x95 ² 1xE-cable 1x185 ² cable-bundle, Ø 10 cm consisting of 20 F-cable, Ø 21 mm
Fire-Resistance	EI 90	EI 60

Würth-Kabelbox

Example for the verification of the construction product "Würth-Kabelbox" as a part of a cable penetration seal, with a fire resistance (integrity and thermal insulation) for more than 60 resp. minutes - Structure of the test specimen; Installation in a flexible wall -

Annex 10

Example of rectangular cableboxes (type 3) in rigid floors

View

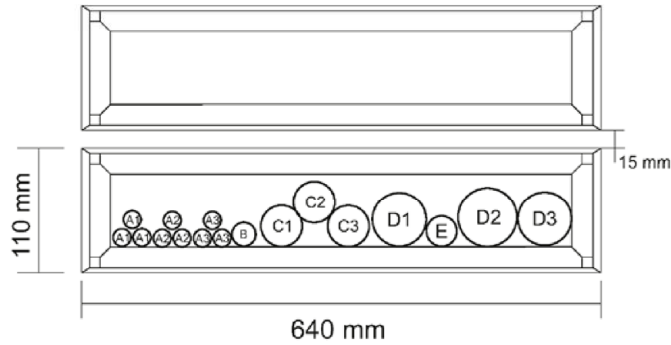

Cross cut

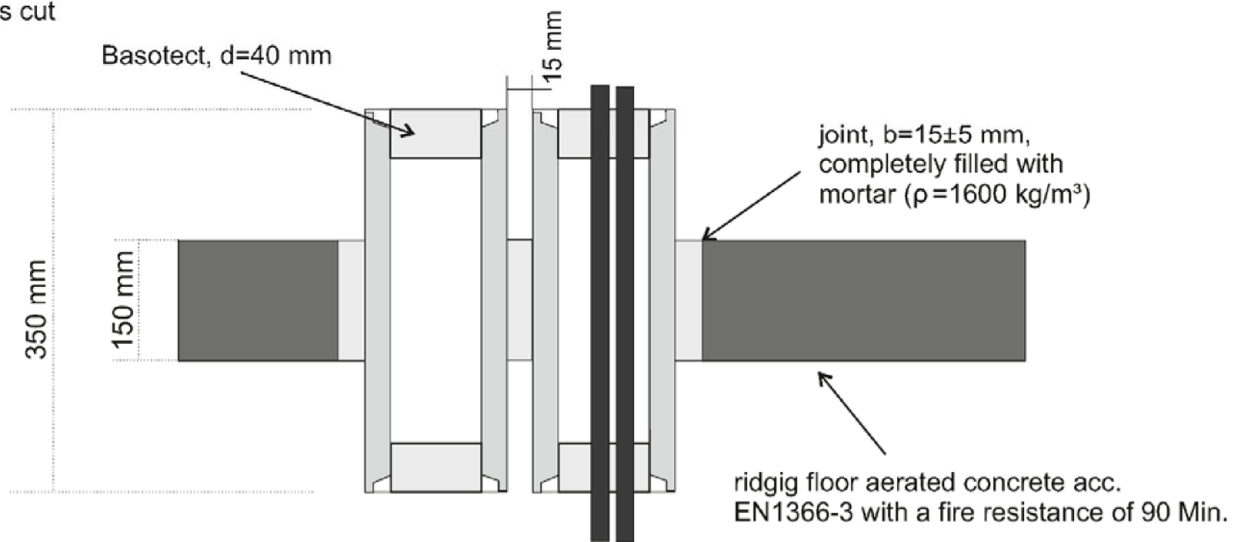

Cable configuration according to EN1366-3:2009-07

- 1xB-Cable 1x95²
- 3xA1-Cable 5x1,5²
- 3xA2-Cable 5x1,5²
- 3xA3-Cable 5x1,5²
- 1xC1-Cable 4x95²
- 1xC2-Cable 4x95²
- 1xC3-Cable 4x95²
- 1xE-Cable 1x185²

- 1xD1-Cable 4x185²
- 1xD2-Cable 4x185²
- 1xD3-Cable 4x185²

Würth-Kabelbox

Example for the verification of the construction product "Würth-Kabelbox" as a part of a cable penetration seal, with a fire resistance (integrity and thermal insulation) for more than 90 minutes - Structure of the test specimen; Installation in a rigid floor -

Annex 11

Example of rectangular cableboxes (type 3) in a flexible wall

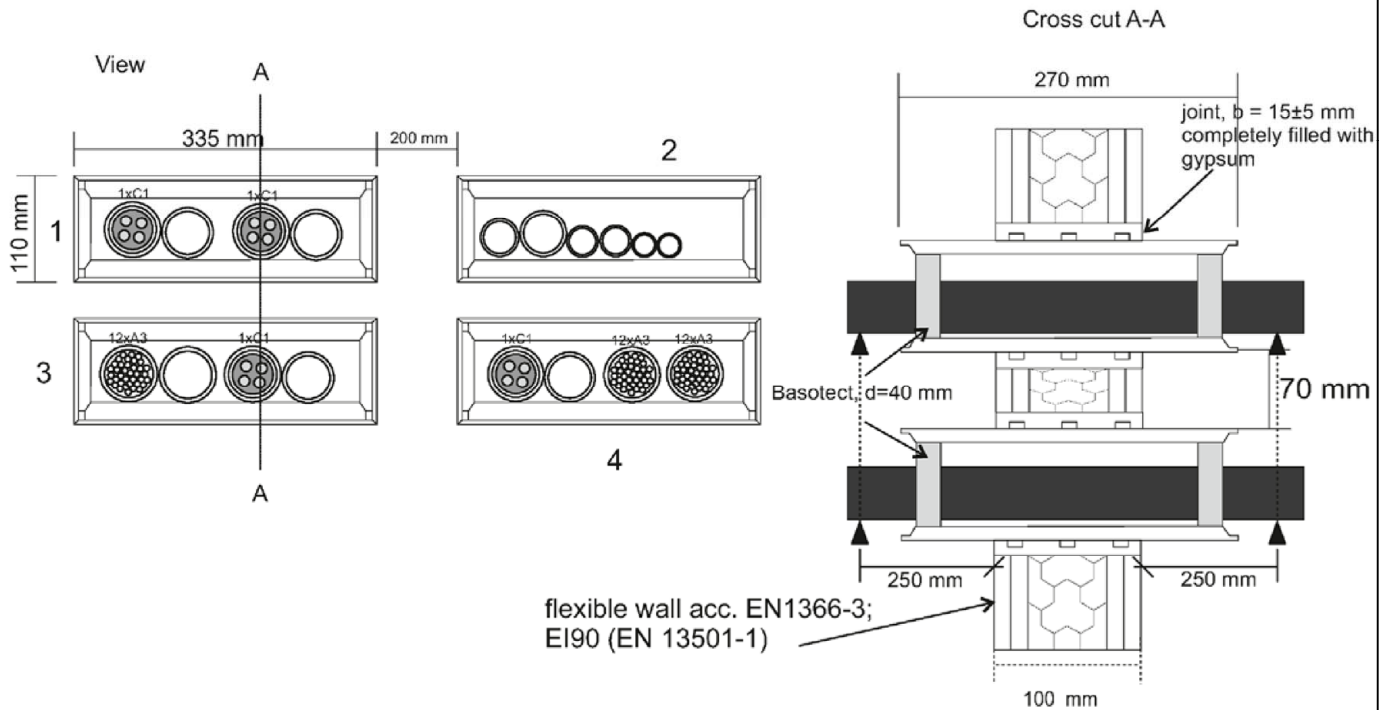

Cable configuration according to EN1366-3:2009-07,
all conduits with \varnothing 63 mm

Box 1:

Polyolefin-conduit FBY-EL-F, with 1xC2-cable 4x95²
PVC-conduit FPKu-EM-F, blank
PE-conduit FFKus-EM-F-105, with 1xC1-cable 4x95²
FFKus-EM-F-LSOH 63 conduit, blank

Box 2: (with graphite strip)

Cu-pipe 42x1,2 with Armaflex HP, 10 mm thickness
Cu-pipe 42x1,2 mm with 10 mm Armaflex HT
Cu-pipe 13x1 mm with 10 mm Armaflex HT
Flexio Split 5/8", SanfixFosta 16x2,2 mm, Flexio Split 1/4"

Box 3:

PE-conduit FPKu-EM-F LSOH, completely filled with various types of A-cable
PVC-conduit FFKus-EM-F, blank
PE-conduit FPKu-EM-F-HO, mit 1xC1-cable 4x95², d.t.o. blank

Box 4:

PVC-conduit FPKu-EM-F, with 1xC1-cable 4x95²
PE-conduit FPKu-EM-F LSOH, blank
PE-conduit FFKuS-EM-F-LSOH, with 8 x A1 + 2 x A2 cable
PVC-conduit FFKus-EM-F, with 4 x A1 + 5 x A2 cable

Würth-Kabelbox

Example for the verification of the construction product "Würth-Kabelbox" as a part of a cable penetration seal, with a fire resistance (integrity and thermal insulation) for more than 90 minutes - Structure of the test specimen; Installation in a flexible wall -

Annex 12

Example of rectangular cablebox (type 3) in a flexible wall

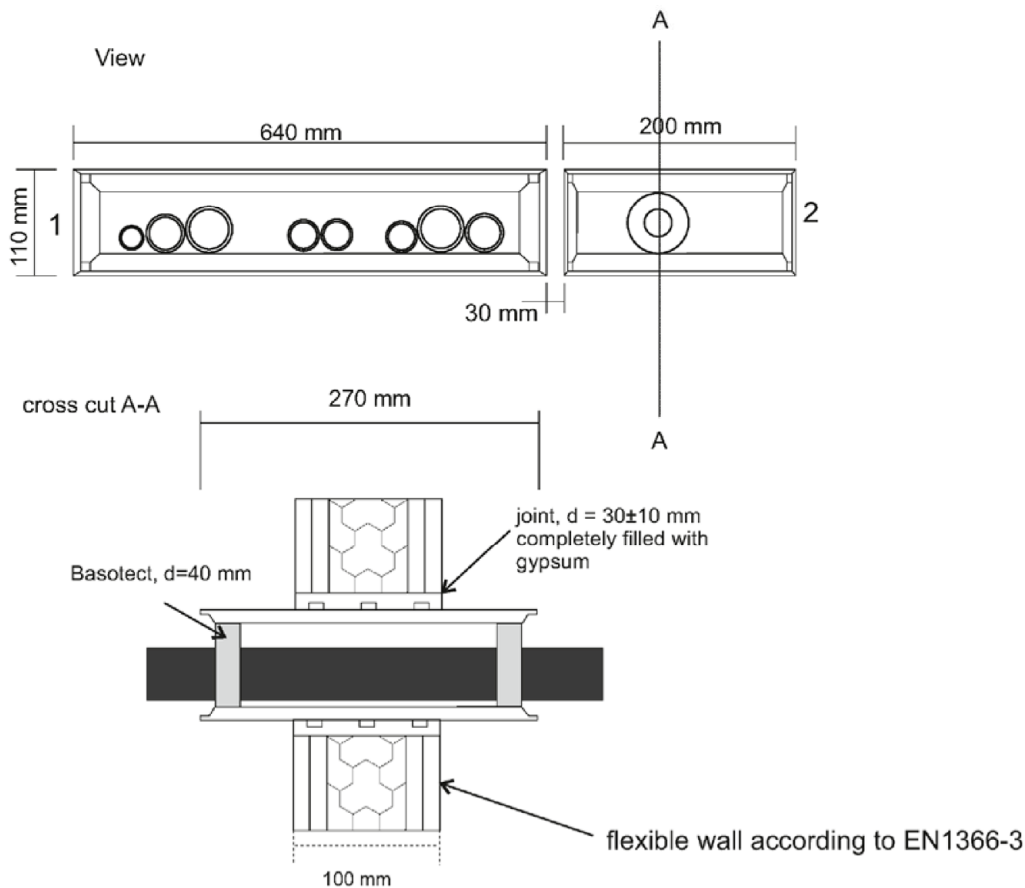

Type	Type 3	
Dimensions	1 Box 110 x 640 x 270 [mm]	1 Box 110 x 200 x 270 [mm]
Configuration	Aquatherm Fusion PP-R 50/8.4 mm Aquatherm green pipe 32x5.4 mm OHM PE-HD pipe 50x4,6 mm OHM PE-HD pipe 40x3,7 mm OHM PE-HD pipe 32x3,0 mm HTGL PP 50x1,8 mm Polokal NG 50x2 mm	Cu-pipe 15x1mm mit Armacel Artiga 24x15 mm

Würth-Kabelbox

Example for the verification of the construction product "Würth-Kabelbox" as a part of a cable penetration seal, with a fire resistance (integrity and thermal insulation) for more than 120 minutes - Structure of the test specimen; Installation in a flexible wall -

Annex 13

Example of threesided cablebox (type 5) with an adjacent extension module (type 4) with an attachment to the floor

View

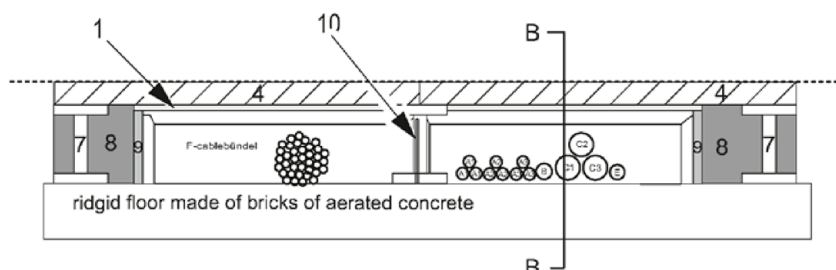

Cross cut (BB) through a cablebox

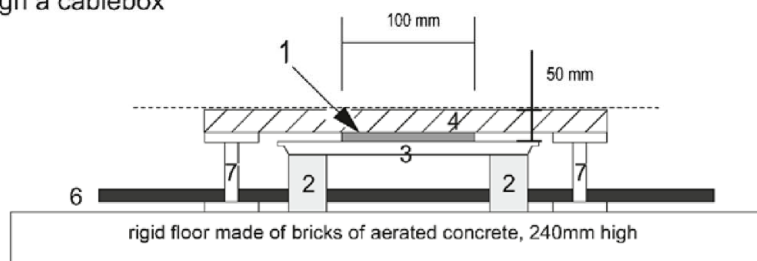

- 1: 3-layers Silica-needle mats, 6 mm thickness
- 2: Foam-stoppers
- 3: 3-sided cablebox 110x535x270 [mm], configuration with cable acc. EN1366-3, C.2.2.1 Nr. 2, option „middle“ and 2-sided cable box cable bundle of Ø 10 cm consisting of cable with Ø 21 mm
- 4: raised floor - elements, 600x600x36 [mm]
- 6: cable
- 7: raised floor - support
- 8: 100 mm mortar
- 9: mortar
- 10: self-adhesive graphite strip

Dimensions	3-sided Box 110 x535 x270 [mm] (type 5) with 2-sided extension module 110 x535 x270 [mm]
Configuration with cable according to EN1366-3:2009-07	<p>within the 3-sided cablebox:</p> <p>1xB-cable 1x95² 3xA1-cable 5x1,5²; 3xA2-cable 5x1,5²; 3xA3-cable 5x1,5² 1xC1-cable 4x95²; 1xC2-cable 4x95²; 1xC3-cable 4x95² 1xE-cable 1x185²</p> <p>within the extension module:</p> <p>cable-bundle of Ø 10 cm consisting of 29 F-cable, Ø 21 mm</p>

Würth-Kabelbox

Example for the verification of the construction product "Würth-Kabelbox" as a part of a cable penetration seal, with a fire resistance (integrity and thermal insulation) for more than 120 minutes - Structure of the test specimen -

Annex 14

Example of rectangular cablebox (type 3) in a rigid floor using PURLOGIC EASY polyurethane foam

Cross cut

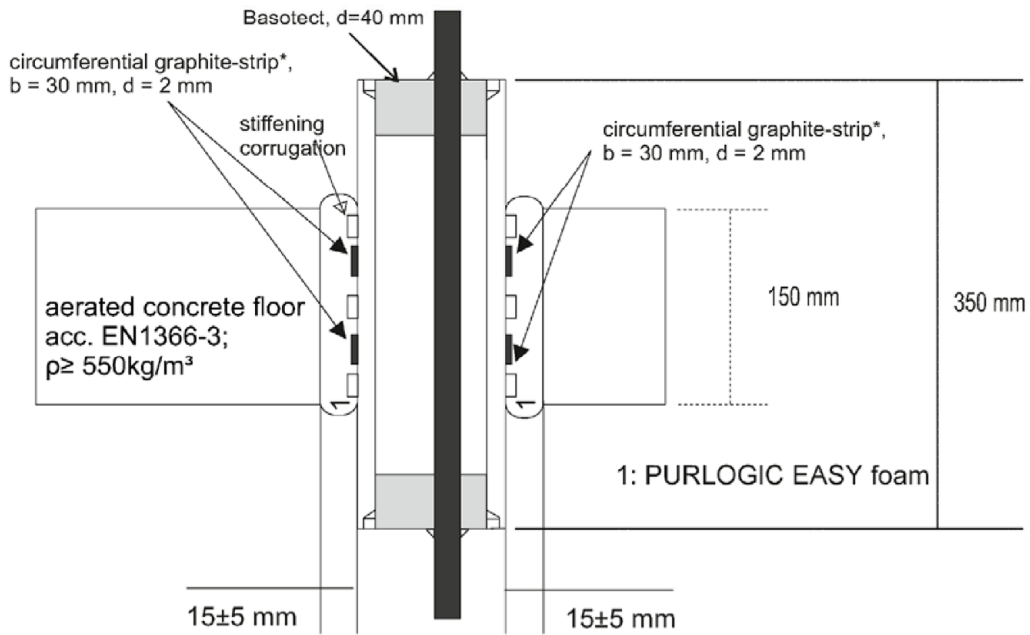

Dimensions	Box 110 mm x 640 mm x 350 mm
Cable - configuration according to EN1366-3	1xB-cable 1x95 ² 3xA1-cable 5x1,5 ² , 3xA2-cable 5x1,5 ² , 3xA3-cable 5x1,5 ² 1xC1-cable 4x95 ² , 1xC2-cable 4x95 ² , 1xC3-cable 4x95 ² 1xE-cable 1x185 ²

* the composite has been lodged at the DIBt

Würth-Kabelbox

Example for the verification of the construction product "Würth-Kabelbox" as a part of a cable penetration seal, with a fire resistance (integrity and thermal insulation) for more than 90 minutes - Structure of the test specimen; Installation in a rigid floor -

Annex 15