

Approval body for construction products
and types of construction

Bautechnisches Prüfamt

An institution established by the Federal and
Laender Governments



European Technical Assessment

ETA-20/0270
of 26 March 2020

English translation prepared by DIBt - Original version in German language

General Part

Technical Assessment Body issuing the
European Technical Assessment:

Deutsches Institut für Bautechnik

Trade name of the construction product

BAUFIX PN 8

Product family
to which the construction product belongs

Nailed-in plastic anchor for fixing of external thermal
insulation composite systems with rendering in concrete
and masonry

Manufacturer

MONOSETO O.E.
Georgikis Scholis Ave. & Marinou Antipa 1
GR 57001 PILEA, THESSALONIKI
GRIECHENLAND

Manufacturing plant

MONOSETO

This European Technical Assessment
contains

12 pages including 3 annexes which form an integral part
of this assessment

This European Technical Assessment is
issued in accordance with Regulation (EU)
No 305/2011, on the basis of

EAD 330196-01-0604

The European Technical Assessment is issued by the Technical Assessment Body in its official language. Translations of this European Technical Assessment in other languages shall fully correspond to the original issued document and shall be identified as such.

Communication of this European Technical Assessment, including transmission by electronic means, shall be in full. However, partial reproduction may only be made with the written consent of the issuing Technical Assessment Body. Any partial reproduction shall be identified as such.

This European Technical Assessment may be withdrawn by the issuing Technical Assessment Body, in particular pursuant to information by the Commission in accordance with Article 25(3) of Regulation (EU) No 305/2011.

Specific Part

1 Technical description of the product

The BAUFIX PN 8 consists of a plastic sleeve made of polypropylene (virgin material), a plate and an accompanying specific nail made of glass fibre reinforced polyamide (virgin material). The anchor may in addition be combined with the slip-on-plate DT 90, DT 110 and DT 140. The product description is given in Annex A.

2 Specification of the intended use in accordance with the applicable European Assessment Document

The performances given in Section 3 are only valid if the anchor is used in compliance with the specifications and conditions given in Annex B.

The verification and assessment methods on which this European Technical Assessment is based lead to the assumption of a working life of the anchor of at least 25 years. The indications given on the working life cannot be interpreted as a guarantee given by the producer, but are to be regarded only as a means for choosing the right products in relation to the expected economically reasonable working life of the works.

3 Performance of the product and references to the methods used for its assessment

3.1 Safety and accessibility in use (BWR 4)

Essential characteristic	Performance
Characteristic tension resistance	See Annex C 1
Edge distances and spacing	See Annex B 2
Plate stiffness	See Annex C 2
Displacements	See Annex C 2

3.2 Energy economy and heat retention (BWR 6)

Essential characteristic	Performance
Point thermal transmittance	See Annex C 2

4 Assessment and verification of constancy of performance (AVCP) system applied, with reference to its legal base

In accordance with EAD No. 330196-01-0604, the applicable European legal act is: [97/463/EC].

The system to be applied is: 2+

5 Technical details necessary for the implementation of the AVCP system, as provided for in the applicable EAD

Technical details necessary for the implementation of the AVCP system are laid down in the control plan deposited with Deutsches Institut für Bautechnik.

Issued in Berlin on 26 March 2020 by Deutsches Institut für Bautechnik

BD Dipl.-Ing. Andreas Kummerow
Head of Department

beglaubigt:
Ziegler

BAUFIX PN 8

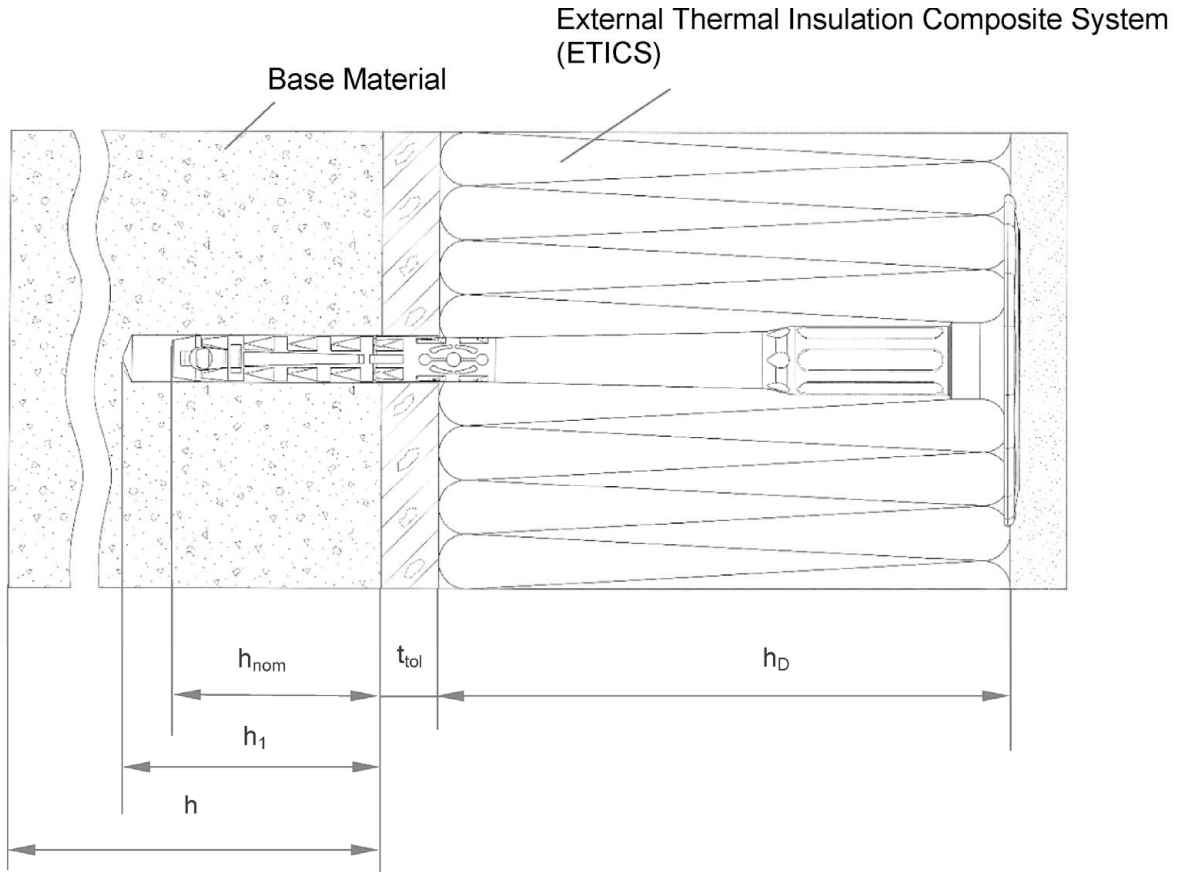

Legend

- h_{nom} = Overall plastic anchor embedment depth in the base material
- h_1 = Depth of drilled hole to deepest point
- h = Thickness of member (wall)
- h_D = Thickness of insulation material
- t_{tol} = Thickness of equalizing layer or non-load bearing coating

BAUFIX PN 8

Product description
Installed anchor

Annex A1

BAUFIX PN 8

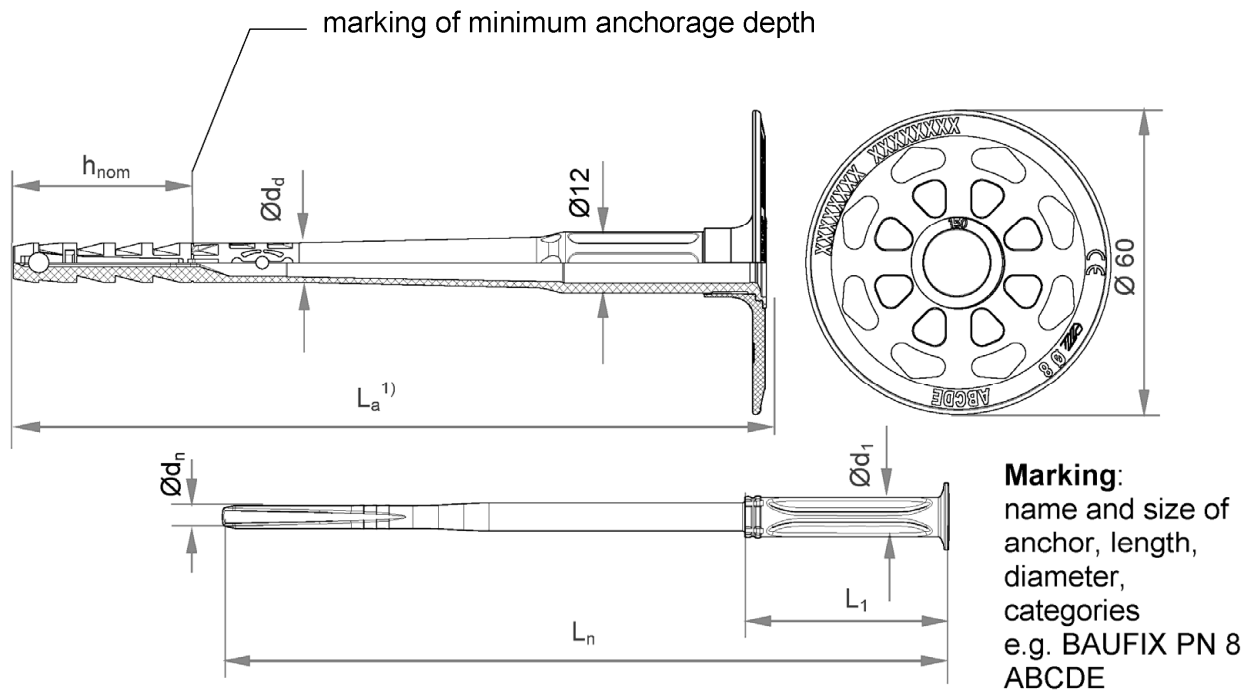

¹⁾ Various length of the anchors are permissible

Table A2.1: Dimensions

Anchor type	Anchor sleeve		Accompanying specific plastic nail		
	Ø d _d [mm]	h _{nom} [mm]	Ø d _n [mm]	L ₁ [mm]	Ø d ₁ [mm]
BAUFIX PN 8	8	35/55 ¹⁾	4,4	40	8

¹⁾ Only for use Cat. D and E

Determination of maximum thickness of insulation: $h_D = L_a - h_{nom} - t_{tol}$

e.g. for BAUFIX PN 8x150:

$L_a = 148 \text{ mm}$, $h_{nom} = 35 \text{ mm}$, $t_{tol} = 10$

$h_D = 148 - 35 - 10 \approx 100 \text{ mm}$

BAUFIX PN 8 :

$L_{a \min} \geq 110 \text{ mm}$; $L_{a \max} \leq 230 \text{ mm}$

$L_a = \text{length of accompanying specific nail } L_n + 5 \text{ mm}$

BAUFIX PN 8

Product description
Dimensions

Annex A2

Table A3.1: Material

Designation	Material
Anchor sleeve	PP (virgin material), colour: grey
Specific plastic nail	PA6 (virgin material) GF, colour: nature
Slip-on plate	PA6 (virgin material), GF colour: grey, orange, red, green, yellow, blue

Drawing of the slip-on plates

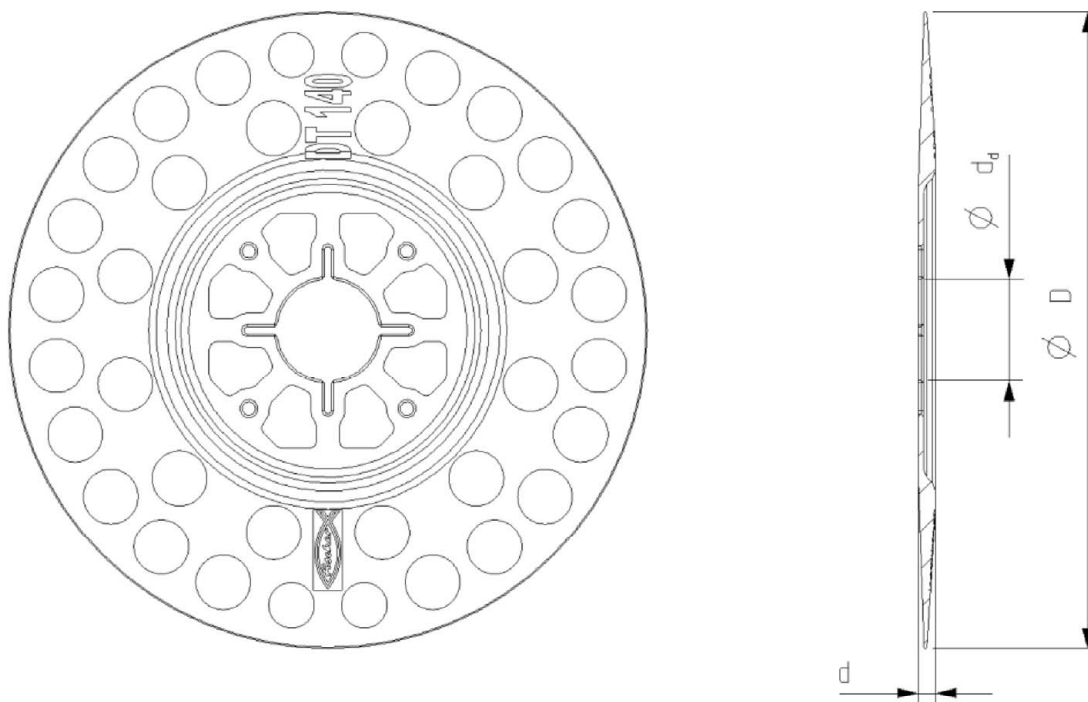

Table A3.2 Slip-on plates, diameters and material

Slip-on plate	Ø D [mm]	Ø d _d [mm]	d [mm]	Material
DT 90 / 110 / 140	90 / 110 / 140	22,5	3,9	PA 6 GF

BAUFIX PN 8

Product description

Material
Slip-on plates combined with BAUFIX PN 8

Annex A3

Specifications of intended use

Anchorage subject to:

- The anchor may only be used for transmission of wind suction loads and shall not be used for the transmission of dead loads of the thermal insulation composite system.

Base materials:

- Normal weight concrete (base material group A) according to Annex C1.
- Solid masonry (base material group B), according to Annex C1.
- Hollow or perforated masonry (base material group C), according to Annex C1.
- Lightweight aggregate concrete (base material group D), according to Annex C1.
- Autoclaved aerated concrete (base material group E), according to Annex C1.
- For other base materials of the base material group A, B, C, D and E the characteristic resistance of the anchor may be determined by job site tests acc. to EOTA Technical Report TR 051 Edition December 2016.

Temperature Range:

- 0°C to +40°C (max. short term temperature +40°C and max. long term temperature +24°C).

Design:

- The anchorages are designed under the responsibility of an engineer experienced in anchorages and masonry work with the partial safety factors $\gamma_M = 2,0$ and $\gamma_M = 1,5$ in absence of other national regulations.
- Verifiable calculation notes and drawings are prepared taking account of the loads to be anchored. The position of the anchors is indicated on the design drawings.
- Fasteners are only to be used for multiple fixings of ETICS.

Installation:

- Drilling method according to Annex C1.
- Anchor installation carried out by appropriately qualified personnel and under the supervision of the person responsible for technical matters on the site.
- Installation temperature from 0°C to +40°C
- Exposure to UV due to solar radiation of the anchor not protected by rendering ≤ 6 weeks.

BAUFIX PN 8

**Intended use
Specification**

Annex B1

Table B2.1: Installation parameters

Anchor type			BAUFIX PN 8
Drill hole diameter	d_0	= [mm]	8
Cutting diameter of drill bit	d_{cut}	≤ [mm]	8,45
Depth of drilled hole to deepest point	h_1	≥ [mm]	45/65 ¹⁾
Overall plastic anchor embedment depth in the base material	h_{nom}	≥ [mm]	35/55 ¹⁾

¹⁾ Only for use categorie "D" and "E"

Table B2.2: Minimum distances and spacings

			BAUFIX PN 8
Minimum thickness of member	h	= [mm]	100
Minimum spacing	s_{min}	= [mm]	100
Minimum edge distance	c_{min}	= [mm]	100

Scheme of distance and spacing

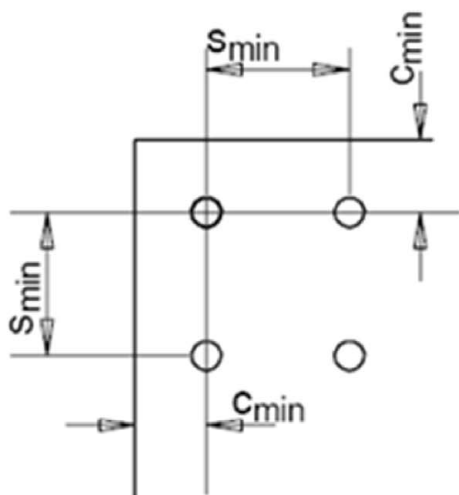

BAUFIX PN 8

Intended use
Installation parameters
Minimum distances and spacings

Annex B2

Installation instructions

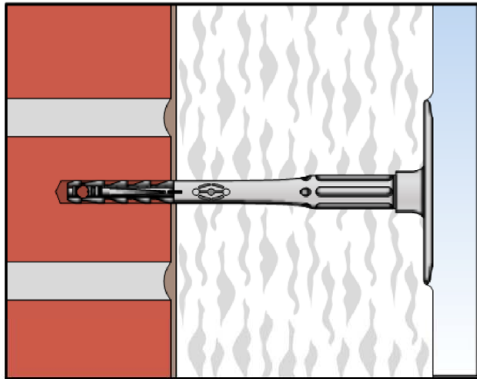
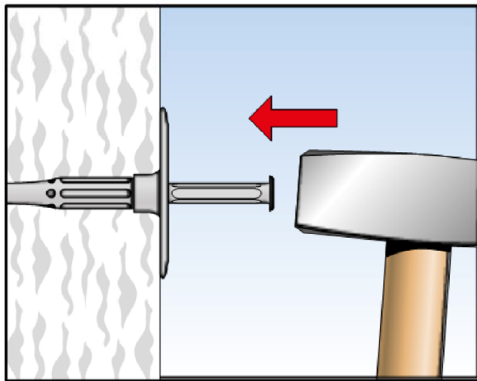
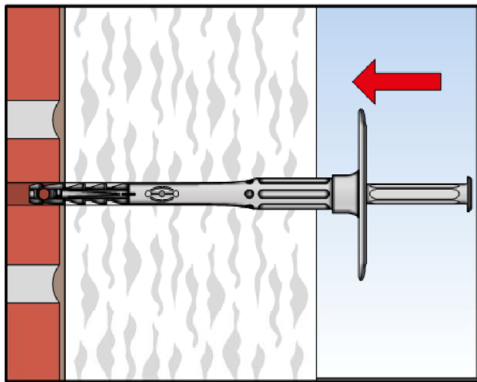
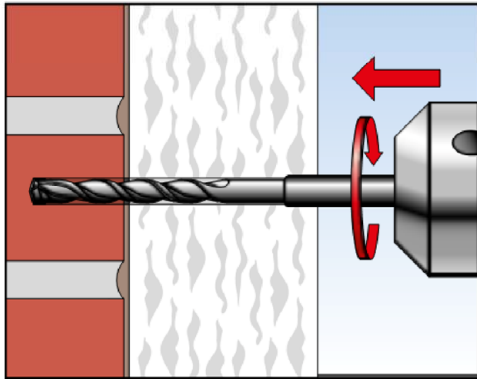

1. Drill hole by corresponding drilling method.

2. Insert anchor manually.

3. Set anchor by hammer-blows.

4. Correctly installed anchor.

BAUFIX PN 8

Intended use
Installation instruction

Annex B3

Table C1.1: Characteristic resistance N_{Rk} in [kN] to tension loads for single anchor

Base material	Use cat. ¹⁾	Bulk density ρ [kg/dm ³]	Min. compressive strength f_b [N/mm ²]	Remarks	Drill method ²⁾	Characteristic resistance N_{Rk} [kN] BAUFIX PN 8
Concrete \geq C12/15 - C50/60 EN 206-1:2011	A	-	-	-	H	0,5
Solid Clay bricks Mz e.g. acc. to EN 771-1:2011	B	$\geq 2,0$	12	Cross section reduced up to 15% by perforation vertically to the resting area	H	0,6
Calcium silicate solid bricks KS e.g. acc. to EN 771-2:2011	B	$\geq 1,8$	12	Cross section reduced up to 15% by perforation vertically to the resting area	H	0,6
Vertically perforated clay bricks HLz e.g. acc. to EN 771-1:2011	C	$\geq 1,0$	12	Cross section reduced between 15% and 50% by perforation vertically to the resting area. Exterior web thickness ≥ 12 mm	R	0,4
Hollow calcium silicate brick KSL acc. to EN 771-2:2011	C	$\geq 1,4$	12	Cross section reduced between 15% and 50% by perforation vertically to the resting area. Exterior web thickness ≥ 23 mm	H	0,4
Lightweight concrete hollow blocks Hbl e.g. acc. to EN 771-3:2011	C	$\geq 1,2$	10	-	H	0,5
Lightweight aggregate concrete LAC e.g. acc. to EN 1520:2011, EN 771-3:2011	D	$\geq 0,9$	4	Minimum exterior web thickness $t = 50$ mm	H	0,3
			6			0,4
Autoclaved aerated concrete blocks AAC e.g. acc. to EN 771-4:2011	E	$\geq 0,5$	4	-	R	0,3
		$\geq 0,6$	6			0,4

¹⁾ See Annex B 1

²⁾ R = Rotary drilling | H = Hammer drilling

BAUFIX PN 8

Performance
Characteristic resistance

Annex C1

**Table C2.1 Point thermal transmittance according to EOTA Technical Report
TR 025: 2016 – 05**

Anchor type	Thickness of insulation material h_D [mm]	Point thermal transmittance χ [W/K]
BAUFIX PN 8	60 - 180	0,000

Table C2.2: Plate stiffness acc. to EOTA Technical Report TR 025 : 2016 – 05

Anchor type	Max. size of the anchor plate [mm]	Load resistance of the anchor plate [kN]	Plate stiffness [kN/mm]
BAUFIX PN 8	60	1,7	0,6

Table C2.3 Displacements

Base material	Tension load N [kN]	Displacements $\Delta\delta_N$ [mm]
Concrete \geq C12/15 – C50/60 (EN 206-1:2000)	0,15	0,2
Clay brick e.g. acc. to EN 771-1:2011, Mz 12	0,20	0,2
Calcium silicate solid bricks e.g. acc. to EN 771-2 :2011,KS 12	0,20	0,3
Vertically perforated clay brick e.g. acc. to EN 771-1:2011,Hlz 12	0,15	0,4
Hollow calcium silicate brick e.g. acc. to EN 771-2:2011, KSL 12	0,15	0,2
Hollow brick lightweight concrete e.g. acc. to EN 771-3:2011, Hbl 4	0,15	0,2
Lightweight aggregate concrete e.g. acc. to EN 1520:2011, EN 771-3:2011	LAC 4	0,2
	LAC 6	
Autoclaved aerated concrete blocks e.g. acc. to EN 771-4:2011	AAC 4	0,1
	AAC 6	0,2

BAUFIX PN 8

Performance
Point thermal transmittance | Plate stiffness
Displacements

Annex C2