

Approval body for construction products
and types of construction

Bautechnisches Prüfamt

An institution established by the Federal and
Laender Governments



European Technical Assessment

ETA-13/0255
of 22 July 2022

English translation prepared by DIBt - Original version in German language

General Part

Technical Assessment Body issuing the
European Technical Assessment:

Deutsches Institut für Bautechnik

Trade name of the construction product

GESIPA®, G-BULB®, PolyGrip®, BULB-TITE®

Product family
to which the construction product belongs

Blind Rivet

Manufacturer

SFS Group Schweiz AG
Rosenbergsaustraße 10
9435 HEERBRUGG
SCHWEIZ

Manufacturing plant

SFS - Factories 9, 13, 14, 24

This European Technical Assessment
contains

43 pages including 36 annexes which form an integral
part of this assessment

This European Technical Assessment is
issued in accordance with Regulation (EU)
No 305/2011, on the basis of

EAD 331064-00-0602

This version replaces

ETA-13/0255 issued on 11 June 2013

The European Technical Assessment is issued by the Technical Assessment Body in its official language. Translations of this European Technical Assessment in other languages shall fully correspond to the original issued document and shall be identified as such.

Communication of this European Technical Assessment, including transmission by electronic means, shall be in full. However, partial reproduction may only be made with the written consent of the issuing Technical Assessment Body. Any partial reproduction shall be identified as such.

This European Technical Assessment may be withdrawn by the issuing Technical Assessment Body, in particular pursuant to information by the Commission in accordance with Article 25(3) of Regulation (EU) No 305/2011.

Specific part

1 Technical description of the product

The blind rivet is a mechanical fastener for the load-bearing connection of metal construction elements. For its installation only one side of the joint must be accessible. The blind rivet consists of a blind rivet body and a mandrel or pin.

The blind rivet head, which is already present at the initial blind rivet body, is positioned on the construction element on the accessible side. For riveting, the mandrel is pulled through the rivet body with a special setting tool. At the end of the setting process the mandrel breaks off at its predetermined breaking point. During the setting process the blind head is formed on the side of the joint opposite the blind rivet head, which then holds the components together. The blind rivet head remains unchanged overall. Annex 1 shows the most important details of blind rivets and the setting process.

Tables 1.1 to 1.4 list the blind rivet types covered by this European Technical Assessment. They are described in more detail in the respective annex in regard of geometry and material.

The surfaces of blind rivet parts made of aluminium or stainless steel are uncoated, those of parts made of unalloyed steel are provided with an electroplated coating (layer thickness about 3 - 5 µm).

Table 1.1 Standard blind rivets (open / closed)

Annex	Blind rivet / Designation (former designation)	Description	Joint ¹
3	BN-C ALA2 4,0 x L F (ASO-D-40 x L)	Aluminium body, open	Steel / Steel
4	BN-C ALA2 4,8xL F (ASO-D-48 x L)	Aluminium body, open	Steel / Steel
5	BN-C ALST 5,0xL F (ATO-D-50 x L) BN-C ALA2 5,0xL F (ASO-D-50 x L)	Aluminium body, open	Steel / Steel
6	BN-C ALST 5,0xL F K11,0 (ATO-D11-50 x L) BN-C ALA2 5,0xL F K11,0 (ASO-D11-50 x L) BN-C ALST 5,0xL F K14,0 (ATO-D14-50 x L) BN-C ALA2 5,0xL F K14,0 (ASO-D14-50 x L)	Aluminium body, open, medium wide head or wide head	Steel / Steel
7	BN-C A2A2 4,0xL F (SSO-D-40 x L) BN-C A4A4 4,0xL F (SSO-D-40 x L-A4)	Stainless steel body, open	Steel / Steel

¹ Joint: Component I (t_i) / Component II (t_{ii})

Table 1.1 continued

Annex	Blind rivet / Designation (former designation)	Description	Joint ¹
8	BN-C A2A2 4,8xL F (SSO-D-48 x L) BN-C A4A4 4,8xL F (SSO-D-48 x L-A4) BN-C A2A2 4,8xL F K15,0 (SSO-D15-48 x L) BN-C A4A4 4,8xL F K15,0 (SSO-D15-48 x L-A4)	Stainless steel body, open, standard head or wide head	Aluminium / Aluminium Aluminium / Steel Steel / Steel
11	CAP-C ALST 4,8xL F (ATC-D-48 x L) CAP-C ALA2 4,8xL F (ASC-D-48 x L)	Aluminium body, closed end (CAP)	Steel / Steel

Table 1.2 High-strength blind rivets G-BULB®

Annex	Blind rivet / Designation (former designation)	Description	Joint ¹
12	GBULB -C STST 4,8xL F (G-BULB-TTO-D-48 x L) GBULB -C A2A2 4,8xL F (G-BULB-SSO-D-48 x L)	Unalloyed steel body, open Stainless steel body, open	Steel / Steel
13	GBULB -C STST 6,4xL F (G-BULB-TTO-D-64 x L) GBULB -C A2A2 6,4xL (G-BULB-SSO-D-64 x L)	Unalloyed steel body, open Stainless steel body, open	Steel / Steel

Table 1.3 Multi range blind rivets PolyGrip®

Annex	Blind rivet / Designation (former designation)	Description	Joint ¹
14	PG-C ALA2 4,0xL F (PolyGrip-ASO-D-40 x L) PG-C ALA2 4,0xL F K12,0 (PolyGrip-ASO-D12-40 x L)	Aluminium body, open, standard head or medium wide head	Steel / Steel
15	PG-C ALA2 4,8xL F (PolyGrip-ASO-D-48 x L) PG-C ALST 4,8xL F (PolyGrip-ATO-D-48 x L) PG-C ALA2 4,8xL F K16,0 (PolyGrip-ASO-D16-48 x L) PG-C ALST 4,8xL F K16,0 (PolyGrip-ATO-D16-48 x L)	Aluminium body, open, standard head or wide head	Aluminium / Aluminium Aluminium / Steel Steel / Steel

Table 1.3 continued

Annex	Blind rivet / Designation (former designation)	Description	Joint ¹
18	PG-C A2A2 4,8xL F (PolyGrip-SSO-D-48 x L)	Stainless steel body, open	Steel / Steel
19	SG-C ALA2 4,8x12,0 K11,4 DS (SOLARGRIP-ASO-D-48120-DS)	Aluminium body, open, for $t_f \geq 2$ mm	Aluminium / Aluminium Aluminium / Steel
21	SG-C ALA2 4,8x15,0 K11,4 DS (SOLARGRIP-ASO-D-48150-DS)	Aluminium body, open for $t_f \geq 4$ mm	Aluminium / Aluminium Aluminium / Steel
23	SG-C ALST 6,4x14,0 F K11,4 (SOLARGRIP-ATO-D-64140)	Aluminium body, open for $t_f \geq 2$ mm	Aluminium / Aluminium Aluminium / Steel

Table 1.4 Triple claw blind rivets BULB-TITE®

Annex	Blind rivet / Designation (former designation)	Description	Joint ¹
25	BT-C ALAL 5,2xL F W (RV6604-6 x L - W)	Aluminium body, open, EPDM washer	Aluminium / Aluminium Aluminium / Steel Steel / Steel
28	BT-C ALAL 6,3xL F W (RV6604-8 x L - W)	Aluminium body, open, EPDM washer	Aluminium / Aluminium Aluminium / Steel Steel / Steel
31	BT-C ALAL 7,7xL F W (RV6603-9 x L - W)	Aluminium body, open, EPDM washer	Aluminium / Aluminium Aluminium / Steel Steel / Steel
34	BT-C MOA2 6,3xL RK (RV6696-8-4 - W)	Ni-Cu alloy body, open	Aluminium / Aluminium Aluminium / Steel Steel / Steel

2 Specification of the intended use in accordance with the applicable European Assessment Document

The blind rivets covered by this European Technical Assessment are intended to be used for joining metal members. They are intended to be used for fastening metal sheeting to metal substructures, joining sheet metals or other thin-gauge metal members primarily applied in lightweight constructions. The joined members are made from aluminium or steel as given in the respective annex and have parallel surfaces which might be coated. Their core thicknesses correspond to the thicknesses for which load-bearing capacity values are given in the annexes.

The blind rivets are intended to be used in connections under static or quasi-static actions whereby the blind rivet is subjected to tension or shear forces.

The blind rivets are intended to be used in joints that are designed in principle according to the calculation methods in EN 1993-1-3:2010 or EN 1999-1-4:2010. Certain boundary conditions specified in these standards may be deviated from, provided that specific information is given in the annexes of this European Technical Assessment. When using the performance values in the design concepts of the Eurocodes, the explanations in the Annexes 1 and 2 should also be taken into account.

The verifications and assessment methods on which this European Technical Assessment is based lead to the assumption of a working life of a blind rivet of at least 25 years. The indications given on the working life cannot be interpreted as a guarantee given by the producer, but are to be regarded only as a means for choosing the right products in relation to the expected economically reasonable working life of the works.

3 Performance of the product and references to the methods used for its assessment

3.1 Mechanical resistance and stability (BWR 1)

Essential characteristic	Performance
Nominal tensile load of blind rivet $F_{t,nom}$	See Annex 3 to Annex 36 (depending on the blind rivet considered)
Nominal shear load of blind rivet $F_{v,nom}$	See Annex 3 to Annex 36 (depending on the blind rivet considered)
Tension resistance of blind rivet $F_{t,Rk}$	no performance assessed
Shear resistance of blind rivet $F_{v,Rk}$	no performance assessed
Mandrel head retention capability $F_{hr,k}$	no performance assessed
Pull-through resistance $F_{p,Rk}$ (blind rivet head)	See Annex 3 to Annex 36 (depending on the blind rivet considered)
Pull-out resistance $F_{o,Rk}$ (blind head)	See Annex 3 to Annex 36 (depending on the blind rivet considered)
Tension resistance in certain joint $F_{j,t,Rk}$	See Annex 3 to Annex 36 (depending on the blind rivet considered)
Shear resistance in certain joint $F_{j,v,Rk}$	See Annex 3 to Annex 36 (depending on the blind rivet considered)

3.2 Safety in case of fire (BWR 2)

Essential characteristic	Performance
Reaction to fire	Class A1

3.3 Aspects of Durability

Essential characteristic	Performance
Corrosion protection	Aluminium blind rivets are uncoated. Stainless steel blind rivets are uncoated. Nickel-copper alloy blind rivets are uncoated. Unalloyed steel blind rivets provide an electroplated coating of about 3 - 5 μm thickness.

4 Assessment and verification of constancy of performance (AVCP) system applied, with reference to its legal base

In accordance with EAD No. 331064-00-0602, the applicable European legal act is: Commission Decision 98/214/EC, as amended by Commission Decision 2001/596/EC

The system to be applied is: 2+

English translation prepared by DIBt

5 Technical details necessary for the implementation of the AVCP system, as provided for in the applicable EAD

Technical details necessary for the implementation of the AVCP system are laid down in the control plan deposited with Deutsches Institut für Bautechnik.

Issued in Berlin on 22 July 2022 by Deutsches Institut für Bautechnik

Dr.-Ing. Ronald Schwuchow
Head of Section

beglaubigt:
Jensky

Blind rivet parts and general scheme of setting process

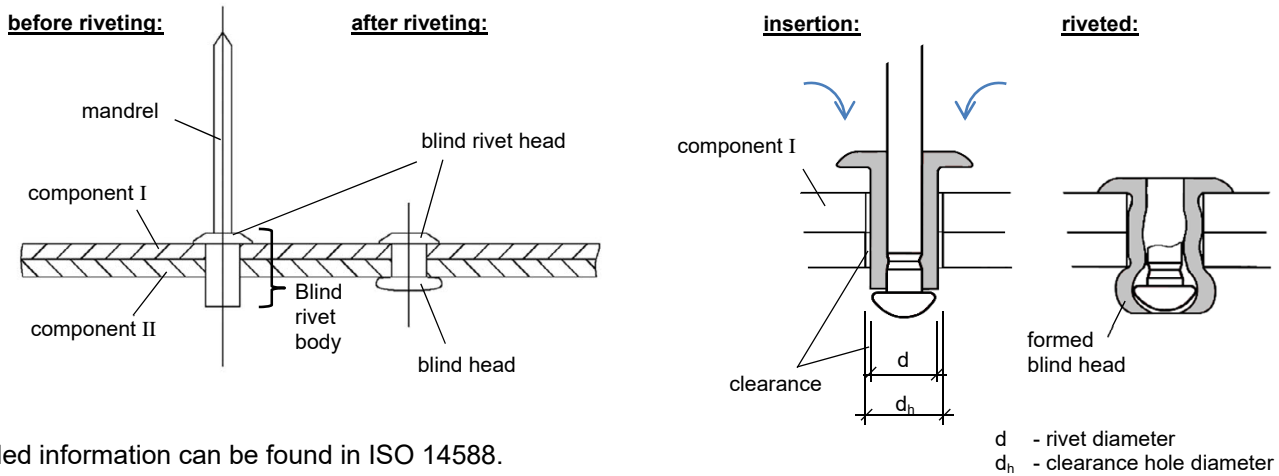

Detailed information can be found in ISO 14588.

Purpose of the load capacity values determined according to EAD 331064-0602

- The nominal values $F_{t,nom}$ for tension and $F_{v,nom}$ for shear are determined in accordance with EN ISO 14589:2001. They represent strength properties of the blind rivet that are completely independent from effects resulting from the geometrical conditions in the joint or from the materials of the joined components. They might be needed to verify compliance with the requirements set out in blind rivet standards such as EN ISO 15973 to EN ISO 15984. The design standard for aluminium structures EN 1999-1-4:2010 presupposes this, for instance, for the application of the calculation scheme given in section 8.2 there. This applies analogously to the mandrel head retention capability $F_{hr,k}$.
- The resistance values $F_{t,Rk}$ for tension and $F_{v,Rk}$ for shear are also determined with a standardised testing device similar to the one described in EN ISO 14589:2001. However, influences of the actual grip length and variations of the hole clearance are also considered. The values are therefore the more practical, rivet-related values and apply to the clamping lengths and hole diameters specified in the annexes. The values reflect the limiting load capacities of the blind rivets in case of pure fastener failure and may be used accordingly in the design concepts according to EN 1993-1-3:2010 and EN 1999-1-4:2010.
- The values $F_{p,Rk}$ for the failure case of the blind rivet head being pulled through a sheet metal and $F_{o,Rk}$ for the failure case of the blind head being pulled out of a sheet metal are determined on real components. These load capacity values refer to a single sheet of a certain material, with a certain thickness and a certain strength. Influences of the hole diameter and the grip length are also considered. Taking into account the boundary conditions specified in the ETA annexes, the values may be used in the verifications according to EN 1993-1-3:2010 and EN 1999-1-4:2010.
- The values $F_{j,t,Rk}$ for the tension resistance and $F_{j,v,Rk}$ for the shear resistance are determined on realistic blind rivet joints. For the respective specified combination of two sheets of specific materials, with specific thicknesses and with specific strengths, they reflect the ultimate load capacity of the entire joint fastened with the blind rivet. Influences of the hole diameter and the grip length are considered. Other boundary conditions as specified in the ETA annexes, e.g. edge distances, shall be taken into account. These values then already represent the lowest load capacity value of the most unfavourable failure case of the respective connection. For shear joints, therefore, there is no need to compare the shear resistance of the blind rivet with the tolerable bearing stress of the hole. For tension connections, the comparison between tensile fracture of the blind rivet, pull-through and pull-out is already covered.

GESIPA®, G-BULB®, PolyGrip®, BULB-TITE®

Information on blind rivets, blind rivet joints and the application of the load capacity tables

Annex 1

Notes on the design of blind rivet joints using the load capacity tables

National regulations may provide for other or supplementary specifications. These take precedence over the following recommendations.

The following is assumed for the assembly of the blind rivet joints:

- The material properties and the core thicknesses t_I and t_{II} of the joint members as stated in each of the tables are observed. With regard to the tolerances for the sheet thicknesses, the specifications in EN 1993-1-3:2010 and EN 1999-1-4:2010 are applied.
- All components to be riveted lie directly against each other. For example, soft intermediate layers, as for thermal separation, are not covered.
- The specifications in the annexes regarding the hole diameters, the edge distances and the grip lengths are observed. Unless exact values for grip lengths are given, the load capacities apply to the grip ranges specified by the manufacturer.

NOTE: The core thicknesses (t_{cor}) given in the annexes for sheets made of steels according to EN 10346 are chosen to correspond to the nominal sheet thicknesses 0.40; 0.50; 0.63; 0.75; 0.88; 1.00; 1.25; 1.50 and 2.00 mm of sheets with a zinc coating "+Z275" equally distributed on both sides ($t_{nom} = t_{cor} + 2 \times t_{zinc}$ with $t_{zinc} = 0.02$ mm).

Due to the test procedures, the stated performance values are in principle only valid in relation to joints with one blind rivet and two sheets lying on top of each other. It may be appropriate to apply the resistance values to connections with additional components also. For this purpose, however, the design rules provided should include guidance on how to convert them, if necessary, and how to take into account the possibly different levels and directions of the forces involved as well as additional aspects like effects of temperature changes. The same applies to joints with more than one blind rivet.

The design values of the load capacities given in the tables should be calculated according to the following scheme:

$$R_d = \frac{\alpha_p \times R_k}{\gamma_{Mi}} \quad \text{The partial factor } \gamma_{Mi} = 1.25 \text{ is recommended.}$$

The reduction factor α_p is only to be applied to pull-through resistance values ($F_{p,Rk}$). In the case of frequently repeated actions on tension (e.g. wind), the factor $\alpha_p = 0,67$ shall be used. Where this is not applicable, the factor shall be applied in accordance with EN 1993-1-3:2010, Figure 8.2 or EN 1999-1-4:2010, Table 8.3.

NOTE 1: The application of the reduction factor for repeated loading does not replace any fatigue checks.

NOTE 2: The resistance values $F_{j,t,Rk}$ and $F_{j,v,Rk}$ given in the annexes for certain joints already include a reduction factor of 0.67 if pull-through was the decisive failure mode.

For a blind rivet loaded in combined shear and tension, the load-bearing capacity of the joint may be verified using:

$$\frac{F_{t,Ed}}{\min(F_{p,Rd}, F_{o,Rd}, F_{t,Rd})} + \frac{F_{v,Ed}}{\min(F_{v,Rd}, F_{b,Rd}, F_{net,Rd})} \leq 1.0 \quad \text{respectively}$$

$$\frac{F_{t,Ed}}{F_{j,t,Rd}} + \frac{F_{v,Ed}}{\min(F_{j,v,Rd}, F_{net,Rd})} \leq 1.0$$

$F_{t,Ed}$ and $F_{v,Ed}$ are the design values of the axial force and the shear force acting on the blind rivet;

$F_{b,Rd}$ is the design value of the bearing resistance and $F_{net,Rd}$ ($F_{n,Rd}$) is the design value of the net-section resistance of the joined sheet metals, each calculated in accordance with EN 1993-1-3:2010 or EN 1999-1-4:2010;

$F_{p,Rk}$, $F_{o,Rk}$, $F_{t,Rk}$, $F_{v,Rk}$, $F_{j,t,Rk}$ and $F_{j,v,Rk}$ are determined by tests in accordance with EAD 331064-00-0602.

GESIPA®, G-BULB®, PolyGrip®, BULB-TITE®

Information on blind rivets, blind rivet joints and the application of the load capacity tables

Annex 2

Geometry

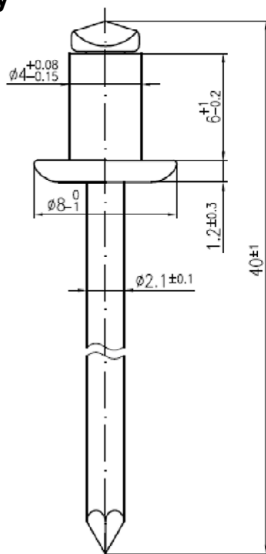

Description of the blind rivet

Material: Body: Aluminium EN AW-5754 [Al Mg3]
Mandrel: Stainless Steel EN 10088-5 – 1.4541

Conditions for validity of the load capacity values

Component I: EN 10346 – S280GD, S320GD, S350GD

Component II: EN 10346 – S280GD, S320GD, S350GD

Maximum drilling diameter: $d_h \leq 4.1$ mm

Minimum end distance: $e_{1,I} \leq 30$ mm; $e_{1,II} \leq 30$ mm

Minimum edge distance: $e_{2,I} \leq 25$ mm; $e_{2,II} \leq 25$ mm

Nominal load bearable by the blind rivet

Tension: ($F_{t,nom}$ not determined) **Shear:** $F_{v,nom} = 1.40$ kN

Characteristic pull-through resistance referred to component I

If $t_i \geq 0.46$ mm $F_{p,Rk} = 0.81$ kN

Characteristic resistance for certain joints / combination of minimum sheet thicknesses – [kN]

Sheet metal combination		Component II – core thickness t_{II} [mm]								
		0.46	0.59	0.71	0.84	0.96	1.21	1.46	≥ 1.96	
Tension resistance $F_{t,Rk}$	Component I core thickness t_I [mm]	0.46	-	-	-	-	0.54	0.54	0.54	0.54
		0.59	-	-	-	-	0.54	0.54	0.54	0.54
		0.71	-	-	0.54	0.54	0.54	0.54	0.54	0.54
		0.84	-	-	0.54	0.54	0.54	0.54	0.54	0.54
		0.96	-	-	0.54	0.54	0.54	0.54	0.54	0.54
		1.21	-	-	0.54	0.54	0.54	0.54	0.54	0.54
		1.46	0.41 *)	0.49 *)	0.54	0.54	0.54	0.54	0.54	0.54
		≥ 1.96	0.41	0.49	0.54	0.54	0.54	0.54	0.54	0.54
Shear resistance $F_{v,Rk}$	Component I core thickness t_I [mm]	0.46	-	-	-	-	0.97	0.97	0.97	0.97
		0.59	-	-	-	-	0.97	0.97	0.97	0.97
		0.71	-	-	0.97	0.97	0.97	0.97	0.97	0.97
		0.84	-	-	0.97	0.97	0.97	0.97	0.97	0.97
		0.96	-	-	0.97	0.97	0.97	0.97	0.97	0.97
		1.21	-	-	0.97	0.97	0.97	0.97	0.97	0.97
		1.46	0.97	0.97	0.97	0.97	0.97	0.97	0.97	0.97
		≥ 1.96	0.97	0.97	0.97	0.97	0.97	0.97	0.97	0.97

*) corresponds to $F_{o,Rk}$ (referred to t_{II})

GESIPA®, G-BULB®, PolyGrip®, BULB-TITE®

Blind rivet: **BN-C ALA2 4,0 x L F**

Annex 3

Geometry

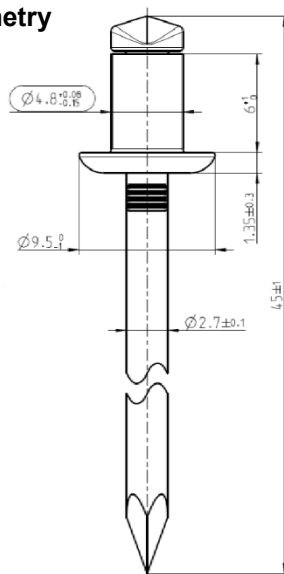

Description of the blind rivet

Material: Body: Aluminium EN AW-5754 [Al Mg3]
Mandrel: Stainless Steel EN 10088-5 – 1.4541

Conditions for validity of the load capacity values

Component I: EN 10346 – S280GD, S320GD, S350GD
Component II: EN 10346 – S280GD, S320GD, S350GD

Maximum drilling diameter: $d_h \leq 4.9$ mm

Minimum end distance: $e_{1,I} \leq 30$ mm; $e_{1,II} \leq 30$ mm

Minimum edge distance: $e_{2,I} \leq 25$ mm; $e_{2,II} \leq 25$ mm

Nominal load bearable by the blind rivet

Tension: ($F_{t,nom}$ not determined) **Shear:** $F_{v,nom} = 1.80$ kN

Characteristic resistance for certain joints / combination of minimum sheet thicknesses – [kN]

Sheet metal combination		Component II – core thickness t_{II} [mm]								
		0.46	0.59	0.71	0.84	0.96	1.21	1.46	≥ 1.96	
Tension resistance $F_{t,Rk}$	Component I core thickness t_I [mm]	0.46	-	-	-	-	-	-	1.10	1.10
		0.59	-	-	-	-	-	-	1.39	1.39
		0.71	-	-	-	-	-	1.48 *)	1.65	1.65
		0.84	-	-	-	-	-	1.48	1.65	1.65
		0.96	-	-	-	-	-	1.48	1.65	1.65
		1.21	-	-	0.52 *)	0.76 *)	0.99 *)	1.48	1.65	1.65
		1.46	0.33 *)	0.43 *)	0.52	0.76	0.99	1.48	1.65	1.65
		≥ 1.96	0.33	0.43	0.52	0.76	0.99	1.48	1.65	1.65
Shear resistance $F_{v,Rk}$	Component I core thickness t_I [mm]	0.46	-	-	-	-	-	-	1.60	1.60
		0.59	-	-	-	-	-	-	1.60	1.60
		0.71	-	-	-	-	-	1.55	1.60	1.60
		0.84	-	-	-	-	-	1.55	1.60	1.60
		0.96	-	-	-	-	-	1.55	1.60	1.60
		1.21	-	-	1.45	1.48	1.50	1.55	1.60	1.60
		1.46	1.06	1.26	1.45	1.48	1.50	1.55	1.60	1.60
		≥ 1.96	1.06	1.26	1.45	1.48	1.50	1.55	1.60	1.60

*) corresponds to $F_{o,Rk}$ (referred to t_{II})

GESIPA®, G-BULB®, PolyGrip®, BULB-TITE®

Blind rivet: **BN-C ALA2 4,8xL F**

Annex 4

English translation prepared by DIBt

Geometry

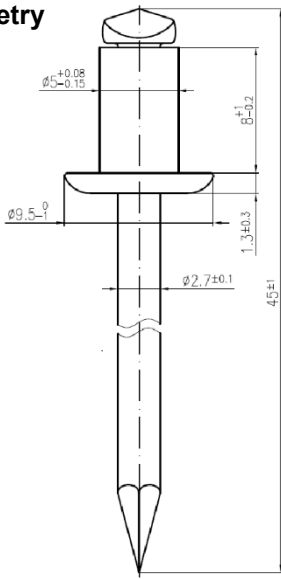

Description of the blind rivet

Material: Body: Aluminium EN AW-5754 [Al Mg3]
Mandrel: Carbon steel EN 10016-2 – 1.0530 (ALST)
Stainless Steel EN 10088-5 – 1.4541 (ALA2)

Conditions for validity of the load capacity values

Component I: EN 10346 – S280GD, S320GD, S350GD
Component II: EN 10346 – S280GD, S320GD, S350GD

Maximum drilling diameter: $d_h \leq 5.1$ mm

Minimum end distance: $e_{1,I} \leq 30$ mm; $e_{1,II} \leq 30$ mm

Minimum edge distance: $e_{2,I} \leq 25$ mm; $e_{2,II} \leq 25$ mm

Nominal load bearable by the blind rivet

Tension: $F_{t,nom} = 2.80$ kN

Shear: ($F_{v,nom}$ not determined)

Characteristic resistance for certain joints / combination of minimum sheet thicknesses – [kN]

Sheet metal combination		Component II – core thickness t_{II} [mm]								
		0.46	0.59	0.71	0.84	0.96	1.21	1.46	≥ 1.96	
Tension resistance $F_{t,Rk}$	Component I core thickness t_I [mm]	0.46	-	-	-	-	-	-	-	1.10
		0.59	-	-	-	-	-	-	-	1.10
		0.71	-	-	-	-	-	-	-	1.65
		0.84	-	-	-	-	-	-	-	1.65
		0.96	-	-	-	-	-	-	1.65	1.65
		1.21	-	-	-	-	-	1.65	1.65	1.65
		1.46	-	-	-	-	1.65	1.65	1.65	1.65
		≥ 1.96	0.41 *)	0.95	1.33	1.62	1.65	1.65	1.65	1.65
Shear resistance $F_{v,Rk}$	Component I core thickness t_I [mm]	0.46	-	-	-	-	-	-	-	1.51
		0.59	-	-	-	-	-	-	-	1.62
		0.71	-	-	-	-	-	-	-	1.62
		0.84	-	-	-	-	-	-	-	1.62
		0.96	-	-	-	-	-	-	1.62	1.62
		1.21	-	-	-	-	-	1.62	1.62	1.62
		1.46	-	-	-	-	1.62	1.62	1.62	1.62
		≥ 1.96	1.16	1.62	1.62	1.62	1.62	1.62	1.62	1.62

*) corresponds to $F_{o,Rk}$ (referred to t_{II})

GESIPA®, G-BULB®, PolyGrip®, BULB-TITE®

Blind rivets: **BN-C ALST 5,0xL F** and **BN-C ALA2 5,0xL F**

Annex 5

English translation prepared by DIBt

Geometry

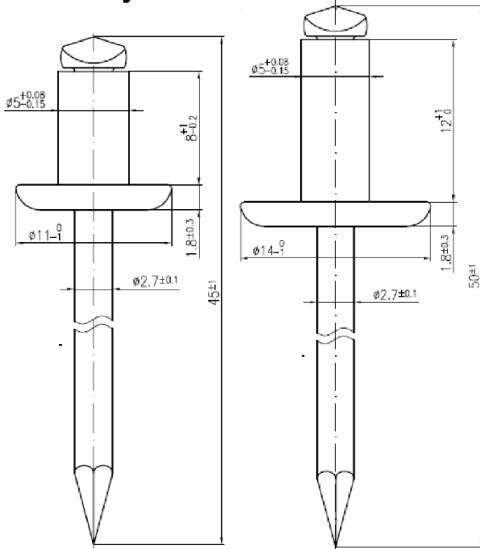

Description of the blind rivet

Material: Body: Aluminium EN AW-5754 [Al Mg3]
Mandrel: Carbon steel EN 10016-2 – 1.0530 (ALST)
Stainless Steel EN 10088-5 – 1.4541 (ALA2)

Conditions for validity of the load capacity values

Component I: EN 10346 – S280GD, S320GD, S350GD
Component II: EN 10346 – S280GD, S320GD, S350GD

Maximum drilling diameter: $d_h \leq 5.1$ mm

Minimum end distance: $e_{1,I} \leq 30$ mm; $e_{1,II} \leq 30$ mm

Minimum edge distance: $e_{2,I} \leq 25$ mm; $e_{2,II} \leq 25$ mm

Nominal load bearable by the blind rivet

Tension: $F_{t,nom} = 2.80$ kN

Shear: $F_{v,nom} = 2.00$ kN

Characteristic resistance for certain joints / combination of minimum sheet thicknesses – [kN]

Sheet metal combination		Component II – core thickness t_{II} [mm]								
		0.46	0.59	0.71	0.84	0.96	1.21	1.46	1.96	
Tension resistance $F_{t,Rk}$	Component I core thickness t_I [mm]	0.46	-	-	-	-	-	-	-	1.24
		0.59	-	-	-	-	-	-	-	1.52
		0.71	-	-	-	-	-	-	-	1.52
		0.84	-	-	-	-	-	-	-	1.62
		0.96	-	-	-	-	-	-	1.81	1.81
		1.21	-	-	-	-	-	2.47	2.47	2.47
		1.46	-	-	-	-	1.81	2.47	2.47	2.47
		≥ 1.96	0.41 *)	0.95	1.33	1.62	1.81	2.47	2.47	2.47
Shear resistance $F_{v,Rk}$	Component I core thickness t_I [mm]	0.46	-	-	-	-	-	-	-	1.51
		0.59	-	-	-	-	-	-	-	1.62
		0.71	-	-	-	-	-	-	-	1.62
		0.84	-	-	-	-	-	-	-	1.62
		0.96	-	-	-	-	-	-	1.62	1.62
		1.21	-	-	-	-	-	1.62	1.62	1.62
		1.46	-	-	-	-	1.62	1.62	1.62	1.62
		≥ 1.96	1.16	1.62	1.62	1.62	1.62	1.62	1.62	1.62

*) corresponds to $F_{o,Rk}$ (referred to t_{II})

GESIPA®, G-BULB®, PolyGrip®, BULB-TITE®

Blind rivets: **BN-C ALST 5,0xL F K11,0** and **BN-C ALA2 5,0xL F K11,0**
BN-C ALST 5,0xL F K14,0 and **BN-C ALA2 5,0xL F K14,0**

Annex 6

English translation prepared by DIBt

Geometry

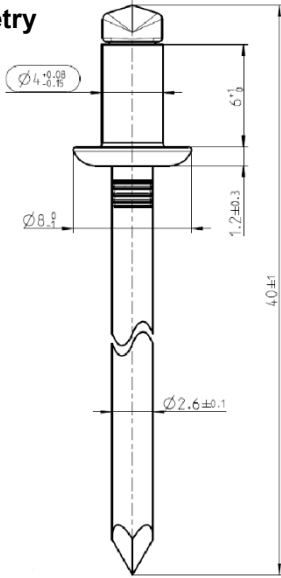

Description of the blind rivet

Material: Body: Stainless Steel EN 10088-5 – 1.4567
Mandrel: Stainless Steel EN 10088-5 – 1.4541 (A2A2)
Body: Stainless Steel EN 10088-5 – 1.4401
Mandrel: Stainless Steel EN 10088-5 – 1.4571 (A4A4)

Conditions for validity of the load capacity values

Component I: EN 10346 – S280GD, S320GD, S350GD
Component II: EN 10346 – S280GD, S320GD, S350GD

Maximum drilling diameter: $d_h \leq 4.1$ mm

Minimum end distance: $e_{1,I} \leq 30$ mm; $e_{1,II} \leq 30$ mm

Minimum edge distance: $e_{2,I} \leq 25$ mm; $e_{2,II} \leq 25$ mm

Nominal load bearable by the blind rivet

Tension: ($F_{t,nom}$ not determined) **Shear:** $F_{v,nom} = 2.70$ kN

Characteristic pull-through resistance referred to component I

If $t_i \geq 0.46$ mm $F_{p,Rk} = 1.16$ kN

Characteristic resistance for certain joints / combination of minimum sheet thicknesses – [kN]

	Sheet metal combination	Component II – core thickness t_{II} [mm]								
		0.46	0.59	0.71	0.84	0.96	1.21	1.46	≥ 1.96	
Tension resistance $F_{t,Rk}$	Component I core thickness t_I [mm]	0.46	0.24 *)	0.48	0.48	0.57	0.57	0.67	0.78	0.78
		0.59	0.24	0.48	0.48	0.57	0.57	0.67	0.78	0.78
		0.71	0.24	0.48	0.67	0.76	0.78	0.86	0.95	0.95
		0.84	0.24	0.48	0.67	0.86	0.86	0.95	1.05	1.05
		0.96	0.24	0.48	0.67	1.14	0.95	1.24	1.33	1.33
		1.21	0.24	0.48	0.67	1.14	1.14	1.81	2.47	2.47
		1.46	0.24	0.48	0.67	1.14	1.14	1.81	2.47	2.47
		≥ 1.96	0.24	0.48	0.67	1.14	1.14	1.81	2.47	2.47
Shear resistance $F_{v,Rk}$	Component I core thickness t_I [mm]	0.46	0.95	0.95	0.95	0.95	0.95	0.95	0.95	1.22
		0.59	0.95	1.24	1.24	1.33	1.33	1.43	1.43	1.52
		0.71	0.95	1.24	1.43	1.43	1.52	1.71	1.71	1.81
		0.84	0.95	1.24	1.43	1.81	1.81	2.00	2.00	2.09
		0.96	0.95	1.24	1.43	1.81	2.00	2.09	2.09	2.28
		1.21	0.95	1.24	1.43	1.81	2.00	2.57	2.57	2.57
		1.46	0.95	1.24	1.43	1.81	2.00	2.57	2.57	2.57
		≥ 1.96	0.95	1.24	1.43	1.81	2.00	2.57	2.57	2.57

*) corresponds to $F_{o,Rk}$ (referred to t_{II})

GESIPA®, G-BULB®, PolyGrip®, BULB-TITE®

Blind rivet: **BN-C A2A2 4,0xL F** and **BN-C A4A4 4,0xL F**

Annex 7

English translation prepared by DIBt

Geometry

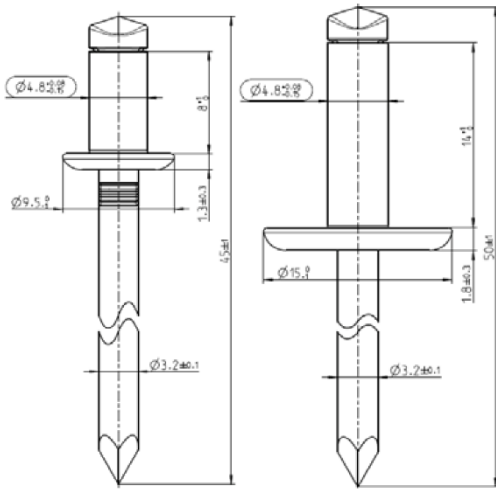

Description of the blind rivet

Material: Body: Stainless Steel EN 10088-5 – 1.4567
Mandrel: Stainless Steel EN 10088-5 – 1.4541 (A2A2)
Body: Stainless Steel EN 10088-5 – 1.4578
Mandrel: Stainless Steel EN 10088-5 – 1.4571 (A4A4)

Conditions for validity of the load capacity values

Component I: EN 10346 – S280GD, S320GD, S350GD
Component II: EN 10346 – S280GD, S320GD, S350GD

Maximum drilling diameter: $d_h \leq 4.9$ mm

Minimum end distance: $e_{1,I} \leq 30$ mm; $e_{1,II} \leq 30$ mm

Minimum edge distance: $e_{2,I} \leq 25$ mm; $e_{2,II} \leq 25$ mm

Nominal load bearable by the blind rivet

Tension: ($F_{t,nom}$ not determined) **Shear:** $F_{v,nom} = 4.00$ kN

Characteristic pull-through resistance referred to component I

If t_i : ≥ 0.46 mm $F_{p,Rk} = 1.29$ kN ≥ 0.71 mm $F_{p,Rk} = 2.77$ kN ≥ 0.96 mm $F_{p,Rk} = 3.08$ kN

Characteristic resistance for certain joints / combination of minimum sheet thicknesses – [kN]

Sheet metal combination		Component II – core thickness t_{II} [mm]							
		0.46	0.59	0.71	0.84	0.96	1.21	1.46	≥ 1.96
Tension resistance $F_{t,Rk}$	Component I core thickness t_I [mm]	0.46	-	-	-	0.62 *)	0.62	0.62	0.62
		0.59	-	-	-	0.62	0.62	0.62	0.62
		0.71	-	-	0.30 *)	0.47	0.62	0.62	0.62
		0.84	-	-	0.30	0.47	0.62	0.62	0.62
		0.96	0.07 *)	0.19 *)	0.30	0.47	0.62	0.62	0.62
		1.21	0.07	0.19	0.30	0.47	0.62	0.62	0.62
		1.46	0.07	0.19	0.30	0.47	0.62	0.62	0.62
		≥ 1.96	0.07	0.19	0.30	0.47	0.62	0.62	0.62
Shear resistance $F_{v,Rk}$	Component I core thickness t_I [mm]	0.46	-	-	-	1.45	1.45	1.45	1.45
		0.59	-	-	-	1.68	1.68	1.68	1.68
		0.71	-	-	1.89	1.89	1.89	1.89	1.89
		0.84	-	-	1.89	1.89	1.89	1.89	1.89
		0.96	1.03	1.46	1.89	1.89	1.89	1.89	1.89
		1.21	1.03	1.46	1.89	1.89	1.89	1.89	1.89
		1.46	1.03	1.46	1.89	1.89	1.89	1.89	1.89
		≥ 1.96	1.03	1.46	1.89	1.89	1.89	1.89	1.89

*) corresponds to $F_{o,Rk}$ (referred to t_{II})

GESIPA®, G-BULB®, PolyGrip®, BULB-TITE®

Blind rivets: **BN-C A2A2 4,8xL F and BN-C A4A4 4,8xL F**
BN-C A2A2 4,8xL F K15,0 and BN-C A4A4 4,8xL F K15,0

Annex 8

Geometry

>>> see Annex 8

Description of the blind rivet

>>> see Annex 8

Conditions for validity of the load capacity values

- Component I: Al alloy acc. to EN 573 – $R_{m,I} \geq 165$ MPa **A**
- Al alloy acc. to EN 573 – $R_{m,I} \geq 215$ MPa **B**
- Component II: Al alloy acc. to EN 573 – $R_{m,II} \geq 165$ MPa **A**
- Al alloy acc. to EN 573 – $R_{m,II} \geq 215$ MPa **B**

Maximum drilling diameter: $d_h \leq 4.9$ mm

Minimum end distance: $e_{1,I} \leq 30$ mm; $e_{1,II} \leq 30$ mm

Minimum edge distance: $e_{2,I} \leq 25$ mm; $e_{2,II} \leq 25$ mm

Characteristic pull-out resistance referred to component II– [kN]

		Component II – core thickness t_{tr} [mm]							
		Sheet metal	0.50	0.70	0.80	0.90	1.00	1.20	1.50
F_{o,Rk}	A ($R_m \geq 165$ MPa)	0.12	0.21	0.25	0.31	0.37	0.40	0.40	0.40
	B ($R_m \geq 215$ MPa)	0.16	0.27	0.32	0.41	0.48	0.61	0.79	1.09

Characteristic resistance for certain joints / combination of minimum sheet thicknesses – [kN]

A		Sheet metal combination	Component II – core thickness t_{tr} [mm] (Al alloy - $R_{m,II} \geq 165$ MPa)							
			0.50	0.70	0.80	0.90	1.00	1.20	1.50	≥ 2.00
Shear resistance $F_{j,v,Rk}$	Component I - t_r [mm] (Al alloy - $R_{m,I} \geq 165$ MPa)	0.50	-	-	-	-	0.59	0.59	0.59	0.59
		0.70	-	-	-	-	0.67	0.67	0.67	0.67
		0.80	-	-	0.72	0.72	0.72	0.72	0.72	0.72
		0.90	-	-	0.72	0.72	0.72	0.72	0.72	0.72
		1.00	0.34	0.60	0.72	0.72	0.72	0.72	0.72	0.72
		1.20	0.34	0.60	0.72	0.72	0.72	0.72	0.72	0.72
		1.50	0.34	0.60	0.72	0.72	0.72	0.72	0.72	0.72
		≥ 2.00	0.34	0.60	0.72	0.72	0.72	0.72	0.72	0.72

B		Sheet metal combination	Component II – core thickness t_{tr} [mm] (Al alloy - $R_{m,II} \geq 215$ MPa)							
			0.50	0.70	0.80	0.90	1.00	1.20	1.50	≥ 2.00
Shear resistance $F_{j,v,Rk}$	Component I - t_r [mm] (Al alloy - $R_{m,I} \geq 215$ MPa)	0.50	-	-	-	-	0.76	0.76	0.76	0.76
		0.70	-	-	-	-	0.88	0.88	0.88	0.88
		0.80	-	-	0.94	0.94	0.94	0.94	0.94	0.94
		0.90	-	-	0.94	0.94	0.94	0.94	0.94	0.94
		1.00	0.45	0.78	0.94	0.94	0.94	0.94	0.94	0.94
		1.20	0.45	0.78	0.94	0.94	0.94	0.94	0.94	0.94
		1.50	0.45	0.78	0.94	0.94	0.94	0.94	0.94	0.94
		≥ 2.00	0.45	0.78	0.94	0.94	0.94	0.94	0.94	0.94

GESIPA®, G-BULB®, PolyGrip®, BULB-TITE®

Blind rivets: **BN-C A2A2 4,8xL F and BN-C A4A4 4,8xL F**
BN-C A2A2 4,8xL F K15,0 and BN-C A4A4 4,8xL F K15,0

Annex 9

Geometry

>>> see Annex 8

Description of the blind rivet

>>> see Annex 8

Conditions for validity of the load capacity values

Component I: Al alloy acc. to EN 573 – $R_{m,I} \geq 165$ MPa **A**
 Al alloy acc. to EN 573 – $R_{m,I} \geq 215$ MPa **B**
 Component II: EN 10346 – S280GD, S320GD, S350GD
 Maximum drilling diameter: $d_h \leq 4.9$ mm
 Minimum end distance: $e_{1,I} \leq 30$ mm; $e_{1,II} \leq 30$ mm
 Minimum edge distance: $e_{2,I} \leq 25$ mm; $e_{2,II} \leq 25$ mm

Characteristic pull-out resistance referred to component II– [kN]

Sheet metal	Component II – core thickness t_{II} [mm]							
	0.46	0.59	0.71	0.84	0.96	1.21	1.46	≥ 1.96
$F_{o,Rk}$ S280GD S320GD S350GD	0.07	0.19	0.30	0.47	0.62	0.62	0.62	0.62

Characteristic resistance for certain joints / combination of minimum sheet thicknesses – [kN]

A	Sheet metal combination	Component II – core thickness t_{II} [mm]								
		0.46	0.59	0.71	0.84	0.96	1.21	1.46	≥ 1.96	
Shear resistance $F_{j,v,Rk}$	Component I - t_I [mm] (Al alloy - $R_{m,I} \geq 165$ MPa)	0.50	-	-	-	-	0.59	0.59	0.59	0.59
		0.70	-	-	-	-	0.67	0.67	0.67	0.67
		0.80	-	-	0.59	0.72	0.72	0.72	0.72	0.72
		0.90	-	-	0.59	0.72	0.72	0.72	0.72	0.72
		1.00	0.34	0.48	0.59	0.72	0.72	0.72	0.72	0.72
		1.20	0.34	0.48	0.59	0.72	0.72	0.72	0.72	0.72
		1.50	0.34	0.48	0.59	0.72	0.72	0.72	0.72	0.72
		≥ 2.00	0.34	0.48	0.59	0.72	0.72	0.72	0.72	0.72

B	Sheet metal combination	Component II – core thickness t_{II} [mm]								
		0.46	0.59	0.71	0.84	0.96	1.21	1.46	≥ 1.96	
Shear resistance $F_{j,v,Rk}$	Component I - t_I [mm] (Al alloy - $R_{m,I} \geq 215$ MPa)	0.50	-	-	-	-	0.76	0.76	0.76	0.76
		0.70	-	-	-	-	0.88	0.88	0.88	0.88
		0.80	-	-	-	0.94	0.94	0.94	0.94	0.94
		0.90	-	-	0.77	0.94	0.94	0.94	0.94	0.94
		1.00	0.45	0.62	0.77	0.94	0.94	0.94	0.94	0.94
		1.20	0.45	0.62	0.77	0.94	0.94	0.94	0.94	0.94
		1.50	0.45	0.62	0.77	0.94	0.94	0.94	0.94	0.94
		≥ 2.00	0.45	0.62	0.77	0.94	0.94	0.94	0.94	0.94

GESIPA®, G-BULB®, PolyGrip®, BULB-TITE®

Blind rivets: **BN-C A2A2 4,8xL F and BN-C A4A4 4,8xL F**
BN-C A2A2 4,8xL F K15,0 and BN-C A4A4 4,8xL F K15,0

Annex 10

Geometry

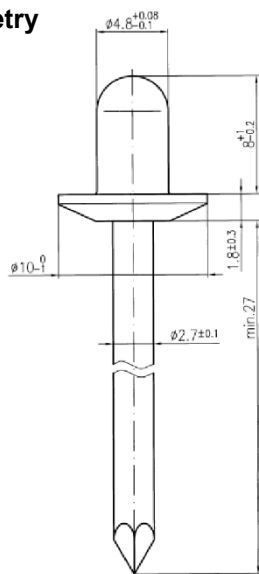

Description of the blind rivet

Material: Body: Aluminium EN AW-5019 [Al Mg5]
Mandrel: Carbon steel EN 10016-2 – 1.0516 (ALST)
Stainless Steel EN 10088-5 – 1.4541 (ALA2)

Conditions for validity of the load capacity values

Component I: EN 10346 – S280GD, S320GD, S350GD

Component II: EN 10346 – S280GD, S320GD, S350GD

Maximum drilling diameter: $d_h \leq 4.9$ mm

Minimum end distance: $e_{1,I} \leq 30$ mm; $e_{1,II} \leq 30$ mm

Minimum edge distance: $e_{2,I} \leq 25$ mm; $e_{2,II} \leq 25$ mm

Nominal load bearable by the blind rivet

Tension: ($F_{t,nom}$ not determined) **Shear:** ($F_{v,nom}$ not determined)

Characteristic resistance for certain joints / combination of minimum sheet thicknesses – [kN]

		Sheet metal combination	Component II – core thickness t_{II} [mm]							
			0.46	0.59	0.71	0.84	0.96	1.21	1.46	≥ 1.96
Tension resistance $F_{j,t,Rk}$	Component I core thickness t_I [mm]	0.46	-	-	-	-	-	-	-	-
		0.59	-	0.76	0.95	1.24	1.33	1.33	1.33	1.33
		0.71	-	0.76	0.95	1.24	1.43	1.43	1.43	1.43
		0.84	-	0.76	0.95	1.24	1.43	1.43	1.43	1.43
		0.96	-	0.76	0.95	1.24	1.43	1.43	1.43	1.43
		1.21	-	0.76	0.95	1.24	1.43	1.52	1.52	1.52
		1.46	-	0.76	0.95	1.24	1.43	1.52	1.52	1.52
		≥ 1.96	-	0.76	0.95	1.24	1.43	1.52	1.52	1.52
Shear resistance $F_{j,v,Rk}$	Component I core thickness t_I [mm]	0.46	-	-	-	-	-	-	-	-
		0.59	-	1.62	1.81	2.00	2.09	2.19	2.19	2.19
		0.71	-	1.71	1.81	2.00	2.09	2.28	2.28	2.28
		0.84	-	1.71	1.81	2.00	2.09	2.28	2.28	2.28
		0.96	-	1.71	1.81	2.00	2.09	2.28	2.28	2.28
		1.21	-	1.71	1.81	2.00	2.09	2.28	2.28	2.28
		1.46	-	1.71	1.81	2.00	2.09	2.28	2.28	2.28
		≥ 1.96	-	1.71	1.81	2.00	2.09	2.28	2.28	2.28

GESIPA®, G-BULB®, PolyGrip®, BULB-TITE®

Blind rivets: **CAP-C ALST 4,8xL F** and **CAP-C ALA2 4,8xL F**

Annex 11

English translation prepared by DIBt

Geometry

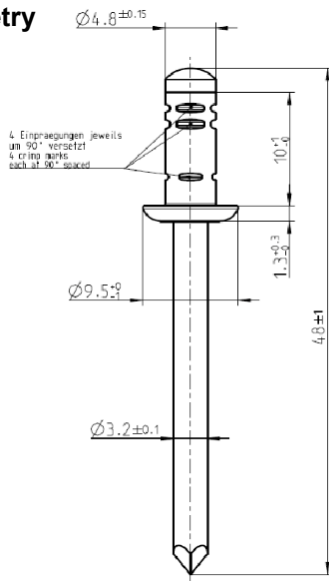

Description of the blind rivet

Material: Body: Carbon steel EN 10016-2 – 1.0234
Mandrel: Carbon steel EN 10016-2 – 1.0586 (STST)
Body: Stainless Steel EN 10088-5 – 1.4567
Mandrel: Stainless Steel EN 10088-5 – 1.4541 (A2A2)

Conditions for validity of the load capacity values

Component I: EN 10346 – S280GD, S320GD, S350GD
Component II: EN 10346 – S280GD, S320GD, S350GD
Maximum drilling diameter: $d_h \leq 5.2$ mm
Minimum end distance: $e_{1,I} \leq 30$ mm; $e_{1,II} \leq 30$ mm
Minimum edge distance: $e_{2,I} \leq 25$ mm; $e_{2,II} \leq 25$ mm

Characteristic resistance for certain joints / combination of minimum sheet thicknesses – [kN]

		Sheet metal combination	Component II – core thickness t_{II} [mm]							
			0.46	0.59	0.71	0.84	0.96	1.21	1.46	≥ 1.96
Tension resistance $F_{t,Rk}$	Component I core thickness t_I [mm]	0.46	-	-	-	-	1.11	1.11	1.11	1.11
		0.59	-	-	-	-	1.28 *)	1.28	1.28	1.28
		0.71	-	-	0.89 *)	1.09 *)	1.28	1.28	1.28	1.28
		0.84	-	-	0.89	1.09	1.28	1.28	1.28	1.28
		0.96	0.39 *)	0.66 *)	0.89	1.09	1.28	1.28	1.28	1.28
		1.21	0.39	0.66	0.89	1.09	1.28	1.28	1.28	1.28
		1.46	0.39	0.66	0.89	1.09	1.28	1.28	1.28	1.28
		≥ 1.96	0.39	0.66	0.89	1.09	1.28	1.28	1.28	1.28
Shear resistance $F_{s,Rk}$	Component I core thickness t_I [mm]	0.46	-	-	-	-	1.40	1.40	1.40	1.40
		0.59	-	-	-	-	1.58	1.58	1.58	1.58
		0.71	-	-	1.75	1.75	1.75	1.75	1.75	1.75
		0.84	-	-	1.75	2.20	2.20	2.20	2.20	2.20
		0.96	0.92	1.35	1.75	2.20	2.63	2.63	2.63	2.63
		1.21	0.92	1.35	1.75	2.20	2.63	2.63	2.63	2.63
		1.46	0.92	1.35	1.75	2.20	2.63	2.63	2.63	2.63
		≥ 1.96	0.92	1.35	1.75	2.20	2.63	2.63	2.63	2.63

*) corresponds to $F_{o,Rk}$ (referred to t_{II})

GESIPA®, G-BULB®, PolyGrip®, BULB-TITE®

Blind rivets: **GBULB-C STST 4,8xL F** and **GBULB-C A2A2 4,8xL F**

Annex 12

English translation prepared by DIBt

Geometry

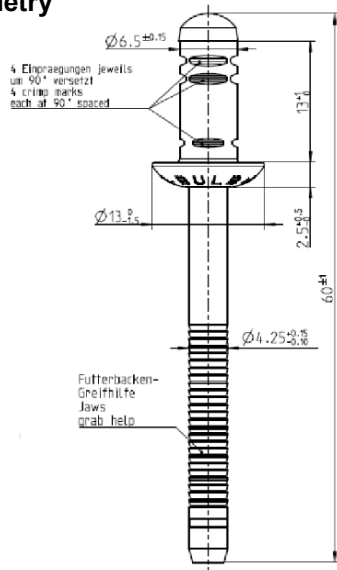

Description of the blind rivet

Material: Body: Carbon steel EN 10016-2 – 1.0234
Mandrel: Carbon steel EN 10016-2 – 1.0611 (STST)
Body: Stainless Steel EN 10088-5 – 1.4567
Mandrel: Stainless Steel EN 10088-5 – 1.4541 (A2A2)

Conditions for validity of the load capacity values

Component I: EN 10346 – S280GD, S320GD, S350GD
Component II: EN 10346 – S280GD, S320GD, S350GD

Maximum drilling diameter: $d_h \leq 6.8 \text{ mm}$

Minimum end distance: $e_{1,I} \leq 30 \text{ mm}; e_{1,II} \leq 30 \text{ mm}$

Minimum edge distance: $e_{2,I} \leq 25 \text{ mm}; e_{2,II} \leq 25 \text{ mm}$

Characteristic resistance for certain joints / combination of minimum sheet thicknesses – [kN]

Sheet metal combination		Component II – core thickness t_{II} [mm]								
		0.46	0.59	0.71	0.84	0.96	1.21	1.46	≥ 1.96	
Tension resistance $F_{t,Rk}$	Component I core thickness t_I [mm]	0.46	-	-	-	-	-	-	1.17	1.17
		0.59	-	-	-	-	-	-	1.17	1.17
		0.71	-	-	-	-	-	1.17	1.17	1.17
		0.84	-	-	-	-	-	1.17	1.17	1.17
		0.96	-	-	-	-	1.17 *)	1.17	1.17	1.17
		1.21	-	-	0.77 *)	0.98 *)	1.17	1.17	1.17	1.17
		1.46	0.43 *)	0.66 *)	0.77	0.98	1.17	1.17	1.17	1.17
		≥ 1.96	0.43	0.66	0.77	0.98	1.17	1.17	1.17	1.17
Shear resistance $F_{v,Rk}$	Component I core thickness t_I [mm]	0.46	-	-	-	-	-	-	1.77	1.77
		0.59	-	-	-	-	-	-	2.68	2.68
		0.71	-	-	-	-	-	3.52	3.52	3.52
		0.84	-	-	-	-	-	3.78	3.78	3.78
		0.96	-	-	-	-	4.03	4.03	4.03	4.03
		1.21	-	-	2.09	3.10	4.03	4.03	4.03	4.03
		1.46	1.30	1.71	2.09	3.10	4.03	4.03	4.03	4.03
		≥ 1.96	1.30	1.71	2.09	3.10	4.03	4.03	4.03	4.03

*) corresponds to $F_{o,Rk}$ (referred to t_{II})

GESIPA®, G-BULB®, PolyGrip®, BULB-TITE®

Blind rivets: **GBULB-C STST 6,4xL F** and **GBULB-C A2A2 6,4xL**

Annex 13

English translation prepared by DIBt

Geometry

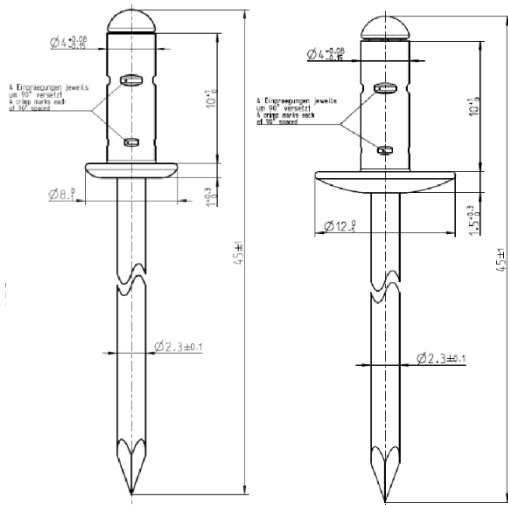

Description of the blind rivet

Material: Body: Aluminium EN AW-5752 [Al Mg2.5]
Mandrel: Stainless Steel EN 10088-5 – 1.4541

Conditions for validity of the load capacity values

Component I: EN 10346 – S280GD, S320GD, S350GD
Component II: EN 10346 – S280GD, S320GD, S350GD
Maximum drilling diameter: $d_h \leq 4.1$ mm
Minimum end distance: $e_{1,I} \leq 30$ mm; $e_{1,II} \leq 30$ mm
Minimum edge distance: $e_{2,I} \leq 25$ mm; $e_{2,II} \leq 25$ mm

Nominal load bearable by the blind rivet

Tension: $F_{t,nom} = 1.68$ kN **Shear:** $F_{v,nom} = 1.06$ kN

Characteristic resistance for certain joints / combination of minimum sheet thicknesses – [kN]

		Sheet metal combination	Component II – core thickness t_{II} [mm]							
			0.46	0.59	0.71	0.84	0.96	1.21	1.46	≥ 1.96
Tension resistance $F_{t,Rk}$	Component I core thickness t_I [mm]	0.46	-	-	-	-	0.74	0.74	0.74	0.74
		0.59	-	-	-	-	0.74	0.74	0.74	0.74
		0.71	-	-	0.74	0.74	0.74	0.74	0.74	0.74
		0.84	-	-	0.74	0.74	0.74	0.74	0.74	0.74
		0.96	0.49 *)	0.73 *)	0.74	0.74	0.74	0.74	0.74	0.74
		1.21	0.49	0.73	0.74	0.74	0.74	0.74	0.74	0.74
		1.46	0.49	0.73	0.74	0.74	0.74	0.74	0.74	0.74
		≥ 1.96	0.49	0.73	0.74	0.74	0.74	0.74	0.74	0.74
Shear resistance $F_{v,Rk}$	Component I core thickness t_I [mm]	0.46	-	-	-	-	0.93	0.93	0.93	0.93
		0.59	-	-	-	-	0.93	0.93	0.93	0.93
		0.71	-	-	0.91	0.92	0.93	0.93	0.93	0.93
		0.84	-	-	0.91	0.92	0.93	0.93	0.93	0.93
		0.96	0.83	0.87	0.91	0.92	0.93	0.93	0.93	0.93
		1.21	0.83	0.87	0.91	0.92	0.93	0.93	0.93	0.93
		1.46	0.83	0.87	0.91	0.92	0.93	0.93	0.93	0.93
		≥ 1.96	0.83	0.87	0.91	0.92	0.93	0.93	0.93	0.93

*) corresponds to $F_{o,Rk}$ (referred to t_{II})

GESIPA®, G-BULB®, PolyGrip®, BULB-TITE®

Blind rivets: **PG-C ALA2 4,0xL F** and **PG-C ALA2 4,0xL F K12,0**

Annex 14

English translation prepared by DIBt

Geometry

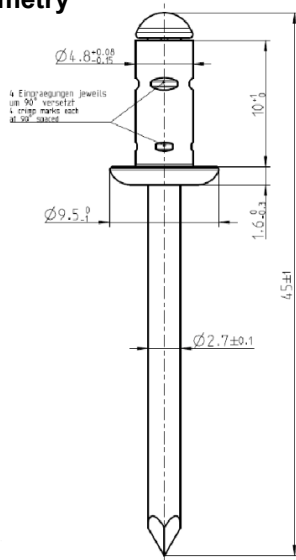

Description of the blind rivet

Material: Body: Aluminium EN AW-5754 [Al Mg3]
Mandrel: Carbon steel EN 10016-2 – 1.0310 (ALST)
Stainless Steel EN 10088 – 1.4541 (ALA2)

Conditions for validity of the load capacity values

Component I: EN 10346 – S280GD, S320GD, S350GD
Component II: EN 10346 – S280GD, S320GD, S350GD

Maximum drilling diameter: $d_h \leq 4.9 \text{ mm}$

Minimum end distance: $e_{1,I} \leq 30 \text{ mm}; e_{1,II} \leq 30 \text{ mm}$

Minimum edge distance: $e_{2,I} \leq 25 \text{ mm}; e_{2,II} \leq 25 \text{ mm}$

Nominal load bearable by the blind rivet

Tension: $F_{t,nom} = 2.30 \text{ kN}$

Shear: $F_{v,nom} = 1.50 \text{ kN}$

Characteristic resistance for certain joints / combination of minimum sheet thicknesses – [kN]

	Sheet metal combination	Component II – core thickness t_{II} [mm]								
		0.36	0.46	0.59	0.71	0.84	0.96	1.21	≥ 1.46	
Tension resistance $F_{t,Rk}$	Component I core thickness t_I [mm]	0.36	0.55	0.71	0.71	0.71	0.71	0.71	0.71	0.71
		0.46	0.55	0.71	0.86	0.86	0.86	0.86	0.86	0.86
		0.59	0.55	0.71	0.95	1.05	1.05	1.05	1.05	1.05
		0.71	0.55	0.71	0.95	1.14	1.14	1.14	1.14	1.14
		0.84	0.55	0.71	0.95	1.24	1.24	1.24	1.24	1.24
		0.96	0.55	0.71	0.95	1.24	1.24	1.24	1.24	1.24
		1.21	0.55	0.71	0.95	1.24	1.24	1.24	1.24	1.24
		≥ 1.46	0.55	0.71	0.95	1.24	1.24	1.24	1.24	1.24
Shear resistance $F_{v,Rk}$	Component I core thickness t_I [mm]	0.36	0.61	0.61	0.61	0.89	0.92	0.95	0.95	0.95
		0.46	0.61	0.85	0.85	1.19	1.19	1.19	1.19	1.19
		0.59	0.61	0.85	1.43	1.43	1.43	1.43	1.43	1.43
		0.71	0.61	0.85	1.43	1.43	1.43	1.43	1.43	1.43
		0.84	0.61	0.85	1.43	1.43	1.43	1.43	1.43	1.43
		0.96	0.61	0.85	1.43	1.43	1.43	1.43	1.43	1.43
		1.21	0.61	0.85	1.43	1.43	1.43	1.43	1.43	1.43
		≥ 1.46	0.61	0.85	1.43	1.43	1.43	1.43	1.43	1.43

GESIPA®, G-BULB®, PolyGrip®, BULB-TITE®

Blind rivets: **PG-C ALA2 4,8xL F** and **PG-C ALST 4,8xL F**
PG-C ALA2 4,8xL F K16,0 and **PG-C ALST 4,8xL F K16,0**

Annex 15

Geometry

>>> see Annex 15

Description of the blind rivet

>>> see Annex 15

Conditions for validity of the load capacity values

- Component I: Al alloy acc. to EN 573 – $R_{m,I} \geq 165$ MPa **A**
- Al alloy acc. to EN 573 – $R_{m,I} \geq 215$ MPa **B**
- Component II: Al alloy acc. to EN 573 – $R_{m,II} \geq 165$ MPa **A**
- Al alloy acc. to EN 573 – $R_{m,II} \geq 215$ MPa **B**

Maximum drilling diameter: $d_h \leq 4.9$ mm

Minimum end distance: $e_{1,I} \leq 30$ mm; $e_{1,II} \leq 30$ mm

Minimum edge distance: $e_{2,I} \leq 25$ mm; $e_{2,II} \leq 25$ mm

Characteristic pull-out resistance referred to component II– [kN]

		Component II – core thickness t_{II} [mm]							
		Sheet metal	0.50	0.70	0.80	0.90	1.00	1.20	1.50
F_{o,Rk}	A ($R_m \geq 165$ MPa)	0.17	0.26	0.29	0.33	0.36	0.36	0.36	0.36
	B ($R_m \geq 215$ MPa)	0.22	0.33	0.39	0.43	0.47	0.47	0.47	0.47

Characteristic resistance for certain joints / combination of minimum sheet thicknesses – [kN]

A		Component II – core thickness t_{II} [mm] (Al alloy - $R_{m,II} \geq 165$ MPa)								
		Sheet metal combination	0.50	0.70	0.80	0.90	1.00	1.20	1.50	≥ 2.00
Shear resistance F_{j,v,Rk}	Component I - t_I [mm] (Al alloy - $R_{m,I} \geq 165$ MPa)	0.50	0.54	0.54	0.54	0.54	0.54	0.54	0.54	0.54
		0.70	0.54	0.79	0.79	0.79	0.79	0.79	0.79	0.79
		0.80	0.54	0.79	0.91	0.91	0.91	0.91	0.91	0.91
		0.90	0.54	0.79	0.91	0.91	0.91	0.91	0.91	0.91
		1.00	0.54	0.79	0.91	0.91	0.91	0.91	0.91	0.91
		1.20	0.54	0.79	0.91	0.91	0.91	0.91	0.91	0.91
		1.50	0.54	0.79	0.91	0.91	0.91	0.91	0.91	0.91
		≥ 2.00	0.54	0.79	0.91	0.91	0.91	0.91	0.91	0.91

B		Component II – core thickness t_{II} [mm] (Al alloy - $R_{m,II} \geq 215$ MPa)								
		Sheet metal combination	0.50	0.70	0.80	0.90	1.00	1.20	1.50	≥ 2.00
Shear resistance F_{j,v,Rk}	Component I - t_I [mm] (Al alloy - $R_{m,I} \geq 215$ MPa)	0.50	0.71	0.71	0.71	0.71	0.71	0.71	0.71	0.71
		0.70	0.71	1.03	1.03	1.03	1.03	1.03	1.03	1.03
		0.80	0.71	1.03	1.19	1.19	1.19	1.19	1.19	1.19
		0.90	0.71	1.03	1.19	1.19	1.19	1.19	1.19	1.19
		1.00	0.71	1.03	1.19	1.19	1.19	1.19	1.19	1.19
		1.20	0.71	1.03	1.19	1.19	1.19	1.19	1.19	1.19
		1.50	0.71	1.03	1.19	1.19	1.19	1.19	1.19	1.19
		≥ 2.00	0.71	1.03	1.19	1.19	1.19	1.19	1.19	1.19

GESIPA®, G-BULB®, PolyGrip®, BULB-TITE®

Blind rivets: **PG-C ALA2 4,8xL F and PG-C ALST 4,8xL F**
PG-C ALA2 4,8xL F K16,0 and PG-C ALST 4,8xL F K16,0

Annex 16

Geometry

>>> see Annex 15

Description of the blind rivet

>>> see Annex 15

Conditions for validity of the load capacity values

Component I: Al alloy acc. to EN 573 – $R_{m,I} \geq 165$ MPa **A**
 Al alloy acc. to EN 573 – $R_{m,I} \geq 215$ MPa **B**
 Component II: EN 10346 – S280GD, S320GD, S350GD
 Maximum drilling diameter: $d_h \leq 4.9$ mm
 Minimum end distance: $e_{1,I} \leq 30$ mm; $e_{1,II} \leq 30$ mm
 Minimum edge distance: $e_{2,I} \leq 25$ mm; $e_{2,II} \leq 25$ mm

Characteristic pull-out resistance referred to component II– [kN]

F _{o,Rk}	Sheet metal	Component II – core thickness t _{II} [mm]							
		0.46	0.59	0.71	0.84	0.96	1.21	1.46	≥ 1.96
	S280GD S320GD S350GD	0.71	0.95	1.24	1.24	1.24	1.24	1.24	1.24

Characteristic resistance for certain joints / combination of minimum sheet thicknesses – [kN]

A	Sheet metal combination	Component II – core thickness t _{II} [mm]								
		0.46	0.59	0.71	0.84	0.96	1.21	1.46	≥ 1.96	
Shear resistance F _{j,v,Rk}	Component I - t _I [mm] (Al alloy - R _{m,I} ≥ 165 MPa)	0.50	0.54	0.54	0.54	0.54	0.54	0.54	0.54	0.54
		0.70	0.54	0.70	0.70	0.70	0.70	0.70	0.70	0.70
		0.80	0.54	0.70	0.86	0.86	0.86	0.86	0.86	0.86
		0.90	0.54	0.70	0.86	0.86	0.86	0.86	0.86	0.86
		1.00	0.54	0.70	0.86	0.86	0.86	0.86	0.86	0.86
		1.20	0.54	0.70	0.86	0.86	0.86	0.86	0.86	0.86
		1.50	0.54	0.70	0.86	0.86	0.86	0.86	0.86	0.86
≥ 2.00	0.54	0.70	0.86	0.86	0.86	0.86	0.86	0.86		

B	Sheet metal combination	Component II – core thickness t _{II} [mm]								
		0.46	0.59	0.71	0.84	0.96	1.21	1.46	≥ 1.96	
Shear resistance F _{j,v,Rk}	Component I - t _I [mm] (Al alloy - R _{m,I} ≥ 215 MPa)	0.50	0.71	0.71	0.71	0.71	0.71	0.71	0.71	0.71
		0.70	0.71	0.92	0.92	0.92	0.92	0.92	0.92	0.92
		0.80	0.71	0.92	1.11	1.19	1.19	1.19	1.19	1.19
		0.90	0.71	0.92	1.11	1.19	1.19	1.19	1.19	1.19
		1.00	0.71	0.92	1.11	1.19	1.19	1.19	1.19	1.19
		1.20	0.71	0.92	1.11	1.19	1.19	1.19	1.19	1.19
		1.50	0.71	0.92	1.11	1.19	1.19	1.19	1.19	1.19
≥ 2.00	0.71	0.92	1.11	1.19	1.19	1.19	1.19	1.19		

GESIPA®, G-BULB®, PolyGrip®, BULB-TITE®

Blind rivets: **PG-C ALA2 4,8xL F and PG-C ALST 4,8xL F**
PG-C ALA2 4,8xL F K16,0 and PG-C ALST 4,8xL F K16,0

Annex 17

English translation prepared by DIBt

Geometry

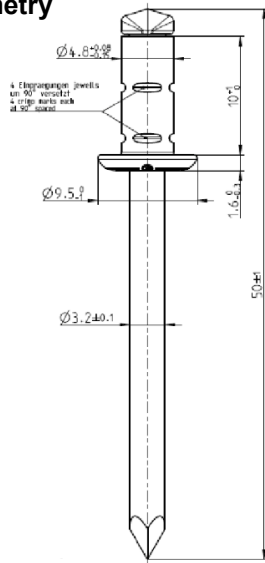

Description of the blind rivet

Material: Body: Stainless Steel EN 10088-5 – 1.4567
Mandrel: Stainless Steel EN 10088-5 – 1.4541

Conditions for validity of the load capacity values

Component I: EN 10346 – S280GD, S320GD, S350GD

Component II: EN 10346 – S280GD, S320GD, S350GD

Maximum drilling diameter: $d_h \leq 4.9$ mm

Minimum end distance: $e_{1,I} \leq 30$ mm; $e_{1,II} \leq 30$ mm

Minimum edge distance: $e_{2,I} \leq 25$ mm; $e_{2,II} \leq 25$ mm

Nominal load bearable by the blind rivet

Tension: ($F_{t,nom}$ not determined) **Shear:** $F_{v,nom} = 4,00$ kN

Characteristic resistance for certain joints / combination of minimum sheet thicknesses – [kN]

		Sheet metal combination	Component II – core thickness t_{II} [mm]							
			0.46	0.59	0.71	0.84	0.96	1.21	1.46	≥ 1.96
Tension resistance $F_{j,t,Rk}$	Component I core thickness t_I [mm]	0.46	-	-	-	-	0.77 *)	0.98 *)	1.18 *)	1.18
		0.59	-	-	-	-	0.77	0.98	1.18	1.18
		0.71	-	-	0.57 *)	0.67 *)	0.77	0.98	1.18	1.18
		0.84	-	-	0.57	0.67	0.77	0.98	1.18	1.18
		0.96	0.29 *)	0.44 *)	0.57	0.67	0.77	0.98	1.18	1.18
		1.21	0.29	0.44	0.57	0.67	0.77	0.98	1.18	1.18
		1.46	0.29	0.44	0.57	0.67	0.77	0.98	1.18	1.18
		≥ 1.96	0.29	0.44	0.57	0.67	0.77	0.98	1.18	1.18
Shear resistance $F_{j,v,Rk}$	Component I core thickness t_I [mm]	0.46	-	-	-	-	1.35	1.35	1.35	1.35
		0.59	-	-	-	-	1.56	1.56	1.56	1.56
		0.71	-	-	1.76	1.76	1.76	1.76	1.76	1.76
		0.84	-	-	1.76	2.14	2.14	2.14	2.14	2.14
		0.96	1.05	1.42	1.76	2.14	2.48	2.48	2.48	2.48
		1.21	1.05	1.42	1.76	2.14	2.48	3.21	3.21	3.21
		1.46	1.05	1.42	1.76	2.14	2.48	3.21	3.93	3.93
		≥ 1.96	1.05	1.42	1.76	2.14	2.48	3.21	3.93	3.93

*) corresponds to $F_{o,Rk}$ (referred to t_{II})

GESIPA®, G-BULB®, PolyGrip®, BULB-TITE®

Blind rivets: **PG-C A2A2 4,8xL F**

Annex 18

English translation prepared by DIBt

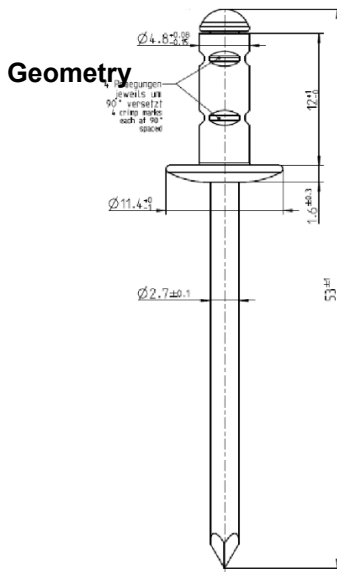

Description of the blind rivet

Material: Body: Aluminium EN AW-5752 [Al Mg2.5]
Mandrel: Stainless Steel EN 10088-5 – 1.4541

Conditions for validity of the load capacity values

Component I: Al alloy acc. to EN 573 – R_{m,I} ≥ 215 MPa

Component II: EN 10346 – S280GD, S320GD, S350GD

Grip range: from 3.00 mm to 5.00 mm

Maximum drilling diameter: d_h ≤ 5.1 mm

Minimum end distance: e_{1,I} ≤ 30 mm; e_{1,II} ≤ 30 mm

Minimum edge distance: e_{2,I} ≤ 25 mm; e_{2,II} ≤ 25 mm

Nominal load bearable by the blind rivet

Tension: (F_{t,nom} not determined) **Shear:** (F_{v,nom} not determined)

Characteristic pull-out resistance referred to component II– [kN]

F _{o,Rk}	Sheet metal	Component II – core thickness t _{II} [mm]							
		0.46	0.59	0.71	0.84	0.96	1.21	1.46	≥ 1.96
F _{o,Rk}	S280GD	0.43	0.59	0.91	1.24	1.53	1.53	1.53	1.53
	S320GD	(0.57)	(0.71)	(1.03)	(1.32)	(1.59)	(1.59)	(1.59)	(1.59)
	S350GD								

Value in brackets may be used in the grip range from 4.00 to 4.50 mm.

Characteristic resistance for certain joints / combination of minimum sheet thicknesses – [kN]

F _{j,v,Rk}	Sheet metal combination	Component II – core thickness t _{II} [mm]							
		0.46	0.59	0.71	0.84	0.96	1.21	1.46	≥ 1.96
F _{j,v,Rk}	Component I t _I [mm] ≥ 2.00	0.87	1.15	1.24	1.24	1.24	1.24	1.24	1.24

GESIPA®, G-BULB®, PolyGrip®, BULB-TITE®

Blind rivets: **SG-C ALA2 4,8x12,0 K11,4 DS**

Annex 19

Geometry

>>> see Annex 19

Description of the blind rivet

>>> see Annex 19

Conditions for validity of the load capacity values

Component I: Al alloy acc. to EN 573 – $R_{m,I} \geq 215$ MPa

Component II: Al alloy acc. to EN 573 – $R_{m,II} \geq 165$ MPa

Al alloy acc. to EN 573 – $R_{m,II} \geq 215$ MPa

A

B

Grip range: from 3.00 mm to 5.00 mm

Maximum drilling diameter: $d_h \leq 5.1$ mm

Minimum end distance: $e_{1,I} \leq 30$ mm; $e_{1,II} \leq 30$ mm

Minimum edge distance: $e_{2,I} \leq 25$ mm; $e_{2,II} \leq 25$ mm

Characteristic pull-out resistance referred to component II– [kN]

	Component II material	Component II – core thickness t_{II} [mm]							
		0.50	0.70	0.80	0.90	1.00	1.20	1.50	≥ 2.00
$F_{o,Rk}$	A $R_m \geq 165$ MPa	0.13 (0.27)	0.28 (0.34)	0.35 (0.38)	0.41 (0.47)	0.47 (0.54)	0.67 (0.84)	0.67 (0.84)	0.67 (0.84)
	B $R_m \geq 215$ MPa	0.17 (0.35)	0.37 (0.46)	0.47 (0.50)	0.54 (0.61)	0.61 (0.70)	0.82 (1.04)	0.82 (1.04)	0.82 (1.04)

Value in brackets may be used in the grip range from 4.00 to 4.50 mm.

Characteristic resistance for certain joints / combination of minimum sheet thicknesses – [kN]

A	Sheet metal combination	Component II – core thickness t_{II} [mm] (Al alloy - $R_{m,II} \geq 165$ MPa)							
		0.50	0.70	0.80	0.90	1.00	1.20	1.50	≥ 2.00
$F_{jv,Rk}$	Component I t_I [mm] ≥ 2.00	0.31	0.51	0.61	0.81	1.01	1.01	1.01	1.01

B	Sheet metal combination	Component II – core thickness t_{II} [mm] (Al alloy - $R_{m,II} \geq 215$ MPa)							
		0.50	0.70	0.80	0.90	1.00	1.20	1.50	≥ 2.00
$F_{jv,Rk}$	Component I t_I [mm] ≥ 2.00	0.42	0.67	0.79	1.05	1.24	1.24	1.24	1.24

GESIPA®, G-BULB®, PolyGrip®, BULB-TITE®

Blind rivets: **SG-C ALA2 4,8x12,0 K11,4 DS**

Annex 20

English translation prepared by DIBt

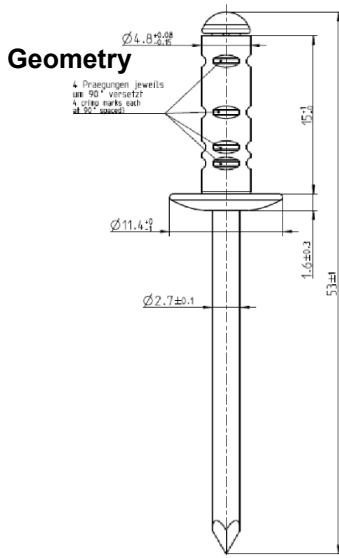

Description of the blind rivet

Material: Body: Aluminium EN AW-5752 [Al Mg2.5]
Mandrel: Stainless Steel EN 10088-5 – 1.4541

Conditions for validity of the load capacity values

Component I: Al alloy acc. to EN 573 – R_{m,I} ≥ 215 MPa

Component II: EN 10346 – S280GD, S320GD, S350GD

Grip range: from 4.50 mm to 9.00 mm

Maximum drilling diameter: d_h ≤ 5.1 mm

Minimum end distance: e_{1,I} ≤ 30 mm; e_{1,II} ≤ 30 mm

Minimum edge distance: e_{2,I} ≤ 25 mm; e_{2,II} ≤ 25 mm

Nominal load bearable by the blind rivet

Tension: (F_{t,nom} not determined) **Shear:** (F_{v,nom} not determined)

Characteristic pull-out resistance referred to component II– [kN]

	Sheet metal	Component II – core thickness t _{II} [mm]							
		0.46	0.59	0.71	0.84	0.96	1.21	1.46	≥ 1.96
F _{o,Rk}	S280GD	0.39	0.59	0.97	1.19	1.39	1.39	1.39	1.39
	S320GD	(0.52)	(0.76)	(1.09)	(1.31)	(1.51)	(1.51)	(1.51)	(1.51)
	S350GD								
Value in brackets may be used in the grip range from 5.00 to 7.00 mm.									

Characteristic resistance for certain joints / combination of minimum sheet thicknesses – [kN]

	Sheet metal combination	Component II – core thickness t _{II} [mm]							
		0.46	0.59	0.71	0.84	0.96	1.21	1.46	≥ 1.96
F _{I,V,Rk}	Component I t _I [mm] ≥ 4.00	1.02	1.23	1.31	1.31	1.31	1.31	1.31	1.31

GESIPA®, G-BULB®, PolyGrip®, BULB-TITE®

Blind rivets: **SG-C ALA2 4,8x15,0 K11,4 DS**

Annex 21

Geometry

>>> see Annex 21

Description of the blind rivet

>>> see Annex 21

Conditions for validity of the load capacity values

Component I: Al alloy acc. to EN 573 – $R_{m,I} \geq 215$ MPa

Component II: Al alloy acc. to EN 573 – $R_{m,II} \geq 165$ MPa **A**

Al alloy acc. to EN 573 – $R_{m,II} \geq 215$ MPa **B**

Grip range: from 4.50 mm to 9.00 mm

Maximum drilling diameter: $d_h \leq 5.1$ mm

Minimum end distance: $e_{1,I} \leq 30$ mm; $e_{1,II} \leq 30$ mm

Minimum edge distance: $e_{2,I} \leq 25$ mm; $e_{2,II} \leq 25$ mm

Characteristic pull-out resistance referred to component II– [kN]

	Component II material	Component II – core thickness t_{II} [mm]							
		0.50	0.70	0.80	0.90	1.00	1.20	1.50	≥ 2.00
F_{o,Rk}	A $R_m \geq 165$ MPa	0.15 (0.25)	0.19 (0.42)	0.21 (0.50)	0.32 (0.58)	0.43 (0.65)	0.46 (1.05)	0.46 (1.05)	0.46 (1.05)
	B $R_m \geq 215$ MPa	0.20 (0.32)	0.25 (0.55)	0.27 (0.67)	0.41 (0.76)	0.55 (0.85)	0.56 (1.31)	0.56 (1.31)	0.56 (1.31)

Value in brackets may be used in the grip range from 5.00 to 7.00 mm.

Characteristic resistance for certain joints / combination of minimum sheet thicknesses – [kN]

A	Sheet metal combination	Component II – core thickness t_{II} [mm] (Al alloy - $R_{m,II} \geq 165$ MPa)							
		0.50	0.70	0.80	0.90	1.00	1.20	1.50	≥ 2.00
F_{j,v,Rk}	Component I t_I [mm] ≥ 4.00	0.33	0.55	0.66	0.82	0.97	0.97	0.97	0.97

B	Sheet metal combination	Component II – core thickness t_{II} [mm] (Al alloy - $R_{m,II} \geq 215$ MPa)							
		0.50	0.70	0.80	0.90	1.00	1.20	1.50	≥ 2.00
F_{j,v,Rk}	Component I t_I [mm] ≥ 4.00	0.43	0.71	0.86	1.06	1.26	1.26	1.26	1.26

GESIPA®, G-BULB®, PolyGrip®, BULB-TITE®

Blind rivets: **SG-C ALA2 4,8x15,0 K11,4 DS**

Annex 22

English translation prepared by DIBt

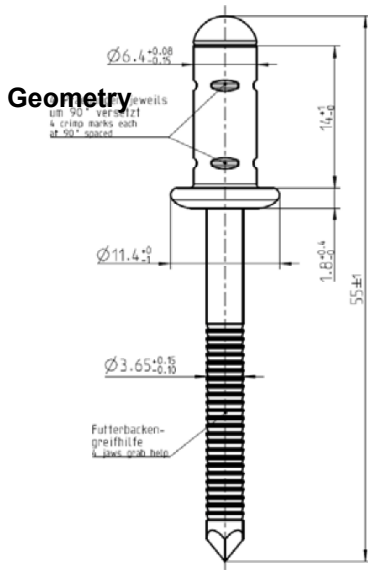

Description of the blind rivet

Material: Body: Aluminium EN AW-5052 [Al Mg2.5]
Mandrel: Carbon steel EN 10016-2 – 1.0541

Conditions for validity of the load capacity values

Component I: Al alloy acc. to EN 573 – $R_{m,I} \geq 215$ MPa
Component II: EN 10346 – S280GD, S320GD, S350GD

Grip range: from 2.50 mm to 8.50 mm

Maximum drilling diameter: $d_h \leq 6.5$ mm

Minimum end distance: $e_{1,I} \leq 30$ mm; $e_{1,II} \leq 30$ mm

Minimum edge distance: $e_{2,I} \leq 25$ mm; $e_{2,II} \leq 25$ mm

Nominal load bearable by the blind rivet

Tension: ($F_{t,nom}$ not determined) **Shear:** ($F_{v,nom}$ not determined)

Characteristic pull-out resistance referred to component II– [kN]

	Sheet metal	Component II – core thickness t_{II} [mm]							
		0.46	0.59	0.71	0.84	0.96	1.21	1.46	≥ 1.96
$F_{o,Rk}$	S280GD	0.67	0.83	1.12	1.30	1.46	1.46	1.46	1.46
	S320GD	(0.77)	(0.97)	(1.40)	(1.71)	(2.00)	(2.00)	(2.00)	(2.00)
	S350GD								
Value in brackets may be used in the grip range from 4.00 to 6.00 mm.									

Characteristic resistance for certain joints / combination of minimum sheet thicknesses – [kN]

	Sheet metal combination	Component II – core thickness t_{II} [mm]							
		0.46	0.59	0.71	0.84	0.96	1.21	1.46	≥ 1.96
$F_{j,v,Rk}$	Component I t_I [mm] ≥ 2.00	0.94	1.77	2.09	2.19	2.66	2.66	2.66	2.66

GESIPA®, G-BULB®, PolyGrip®, BULB-TITE®

Blind rivets: **SG-C ALST 6,4x14,0 F K11,4**

Annex 23

Geometry

>>> see Annex 23

Description of the blind rivet

>>> see Annex 23

Conditions for validity of the load capacity values

Component I: Al alloy acc. to EN 573 – $R_{m,I} \geq 215$ MPa

Component II: Al alloy acc. to EN 573 – $R_{m,II} \geq 165$ MPa **A**

Al alloy acc. to EN 573 – $R_{m,II} \geq 215$ MPa **B**

Grip range: from 2.50 mm to 8.50 mm

Maximum drilling diameter: $d_h \leq 6.5$ mm

Minimum end distance: $e_{1,I} \leq 30$ mm; $e_{1,II} \leq 30$ mm

Minimum edge distance: $e_{2,I} \leq 25$ mm; $e_{2,II} \leq 25$ mm

Characteristic pull-out resistance referred to component II– [kN]

	Component II material	Component II – core thickness t_{II} [mm]							
		0.50	0.70	0.80	0.90	1.00	1.20	1.50	≥ 2.00
$F_{o,Rk}$	A $R_m \geq 165$ MPa	0.25 (0.34)	0.45 (0.53)	0.54 (0.63)	0.69 (0.72)	0.84 (0.82)	1.02 (1.07)	1.02 (1.07)	1.02 (1.07)
	B $R_m \geq 215$ MPa	0.32 (0.45)	0.58 (0.69)	0.71 (0.82)	0.90 (0.95)	1.07 (1.07)	1.26 (1.34)	1.26 (1.34)	1.26 (1.34)

Value in brackets may be used in the grip range from 4.00 to 6.00 mm.

Characteristic resistance for certain joints / combination of minimum sheet thicknesses – [kN]

A	Sheet metal combination	Component II – core thickness t_{II} [mm] (Al alloy - $R_{m,II} \geq 165$ MPa)							
		0.50	0.70	0.80	0.90	1.00	1.20	1.50	≥ 2.00
$F_{j,v,Rk}$	Component I t_I [mm] ≥ 2.00	0.39	0.57	0.67	0.86	1.04	1.04	1.04	1.04

B	Sheet metal combination	Component II – core thickness t_{II} [mm] (Al alloy - $R_{m,II} \geq 215$ MPa)							
		0.50	0.70	0.80	0.90	1.00	1.20	1.50	≥ 2.00
$F_{j,v,Rk}$	Component I t_I [mm] ≥ 2.00	0.50	0.74	0.86	1.11	1.35	1.35	1.35	1.35

GESIPA®, G-BULB®, PolyGrip®, BULB-TITE®

Blind rivets: **SG-C ALST 6,4x14,0 F K11,4**

Annex 24

English translation prepared by DIBt

Geometry

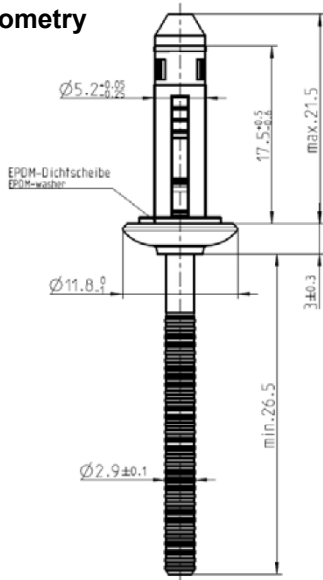

Description of the blind rivet

Material: Body: Aluminium EN AW-5056 [Al Mg5]
Mandrel: Aluminium EN AW-2017 [Al CuMg1]

Conditions for validity of the load capacity values

Component I: EN 10346 – S280GD, S320GD, S350GD
Component II: EN 10346 – S280GD, S320GD, S350GD

Maximum drilling diameter: $d_h \leq 5.4$ mm

Minimum end distance: $e_{1,I} \leq 30$ mm; $e_{1,II} \leq 30$ mm

Minimum edge distance: $e_{2,I} \leq 25$ mm; $e_{2,II} \leq 25$ mm

Nominal load bearable by the blind rivet

Tension: $F_{t,nom} = 1.95$ kN

Shear: $F_{v,nom} = 1.68$ kN

Characteristic resistance for certain joints / combination of minimum sheet thicknesses – [kN]

		Sheet metal combination	Component II – core thickness t_{II} [mm]							
			0.36	0.46	0.59	0.71	0.84	0.96	1.21	≥ 1.46
Tension resistance $F_{t,Rk}$	Component I core thickness t_I [mm]	0.36	-	-	-	-	-	1.13	1.13	1.13
		0.46	-	-	-	-	-	1.13	1.13	1.13
		0.59	-	-	1.05	1.14	1.24	1.24	1.33	1.43
		0.71	-	-	1.05	1.14	1.24	1.33	1.33	1.43
		0.84	-	-	1.05	1.14	1.24	1.43	1.43	1.43
		0.96	0.75 *)	0.75	1.05	1.14	1.24	1.52	1.52	1.52
		1.21	0.75	0.75	1.05	1.14	1.24	1.52	1.62	1.62
		≥ 1.46	0.75	0.75	1.05	1.14	1.24	1.52	1.62	1.71
Shear resistance $F_{v,Rk}$	Component I core thickness t_I [mm]	0.36	-	-	-	-	-	1.07	1.07	1.07
		0.46	-	-	-	-	-	1.19	1.19	1.19
		0.59	-	-	1.33	1.33	1.33	1.33	1.33	1.33
		0.71	-	-	1.33	1.33	1.43	1.52	1.52	1.62
		0.84	-	-	1.43	1.43	1.52	1.52	1.62	1.62
		0.96	0.86	1.11	1.43	1.43	1.62	1.62	1.71	1.81
		1.21	0.86	1.11	1.52	1.52	1.62	1.62	1.71	1.81
		≥ 1.46	0.86	1.11	1.52	1.52	1.62	1.62	1.71	1.81

*) corresponds to $F_{o,Rk}$ (referred to t_{II})

GESIPA®, G-BULB®, PolyGrip®, BULB-TITE®

Blind rivet: **BT-C ALAL 5,2xL F W**

Annex 25

Geometry

>>> see Annex 25

Description of the blind rivet

>>> see Annex 25

Conditions for validity of the load capacity values

- Component I: Al alloy acc. to EN 573 – $R_{m,I} \geq 165$ MPa **A**
- Al alloy acc. to EN 573 – $R_{m,I} \geq 215$ MPa **B**
- Component II: Al alloy acc. to EN 573 – $R_{m,II} \geq 165$ MPa **A**
- Al alloy acc. to EN 573 – $R_{m,II} \geq 215$ MPa **B**

Maximum drilling diameter: $d_h \leq 5.4$ mm

Minimum end distance: $e_{1,I} \leq 30$ mm; $e_{1,II} \leq 30$ mm

Minimum edge distance: $e_{2,I} \leq 25$ mm; $e_{2,II} \leq 25$ mm

Characteristic pull-out resistance referred to component II– [kN]

		Component II – core thickness t_{tr} [mm]							
		Sheet metal	0.50	0.70	0.80	0.90	1.00	1.20	1.50
F_{o,Rk}	A ($R_m \geq 165$ MPa)	0.44	0.67	0.78	0.83	0.87	0.87	0.87	0.87
	B ($R_m \geq 215$ MPa)	0.57	0.86	1.02	1.07	1.13	1.13	1.13	1.13

Characteristic resistance for certain joints / combination of minimum sheet thicknesses – [kN]

A		Sheet metal combination	Component II – core thickness t_{tr} [mm] (Al alloy - $R_{m,II} \geq 165$ MPa)							
			0.50	0.70	0.80	0.90	1.00	1.20	1.50	≥ 2.00
Shear resistance $F_{j,v,Rk}$	Component I - t_r [mm] (Al alloy - $R_{m,I} \geq 165$ MPa)	0.50	-	-	0.62	0.62	0.62	0.62	0.62	0.62
		0.70	-	-	0.79	0.79	0.79	0.79	0.79	0.79
		0.80	0.51	0.75	0.87	0.87	0.87	0.87	0.87	0.87
		0.90	0.51	0.75	0.87	0.99	0.99	0.99	0.99	0.99
		1.00	0.51	0.75	0.87	0.99	1.12	1.12	1.12	1.12
		1.20	0.51	0.75	0.87	0.99	1.12	1.39	1.39	1.39
		1.50	0.51	0.75	0.87	0.99	1.12	1.39	1.78	1.78
		≥ 2.00	0.51	0.75	0.87	0.99	1.12	1.39	1.78	1.85

B		Sheet metal combination	Component II – core thickness t_{tr} [mm] (Al alloy - $R_{m,II} \geq 215$ MPa)							
			0.50	0.70	0.80	0.90	1.00	1.20	1.50	≥ 2.00
Shear resistance $F_{j,v,Rk}$	Component I - t_r [mm] (Al alloy - $R_{m,I} \geq 215$ MPa)	0.50	-	-	0.80	0.80	0.80	0.80	0.80	0.80
		0.70	-	-	1.03	1.03	1.03	1.03	1.03	1.03
		0.80	0.67	0.98	1.14	1.14	1.14	1.14	1.14	1.14
		0.90	0.67	0.98	1.14	1.29	1.29	1.29	1.29	1.29
		1.00	0.67	0.98	1.14	1.29	1.46	1.46	1.46	1.46
		1.20	0.67	0.98	1.14	1.29	1.46	1.81	1.81	1.81
		1.50	0.67	0.98	1.14	1.29	1.46	1.81	2.32	2.32
		≥ 2.00	0.67	0.98	1.14	1.29	1.46	1.81	2.32	2.41

GESIPA®, G-BULB®, PolyGrip®, BULB-TITE®

Blind rivets: **BT-C ALAL 5,2xL F W**

Annex 26

Geometry

>>> see Annex 25

Description of the blind rivet

>>> see Annex 25

Conditions for validity of the load capacity values

Component I: Al alloy acc. to EN 573 – $R_{m,I} \geq 165$ MPa **A**
 Al alloy acc. to EN 573 – $R_{m,I} \geq 215$ MPa **B**
 Component II: EN 10346 – S280GD, S320GD, S350GD
 Maximum drilling diameter: $d_h \leq 5.4$ mm
 Minimum end distance: $e_{1,I} \leq 30$ mm; $e_{1,II} \leq 30$ mm
 Minimum edge distance: $e_{2,I} \leq 25$ mm; $e_{2,II} \leq 25$ mm

Characteristic pull-out resistance referred to component II– [kN]

F _{o,Rk}	Sheet metal	Component II – core thickness t _{II} [mm]							
		0.46	0.59	0.71	0.84	0.96	1.21	1.46	≥ 1.96
S280GD S320GD S350GD	0.72	1.05	1.14	1.24	1.52	1.62	1.71	1.71	

Characteristic resistance for certain joints / combination of minimum sheet thicknesses – [kN]

A

Sheet metal combination		Component II – core thickness t _{II} [mm]							
		0.46	0.59	0.71	0.84	0.96	1.21	1.46	≥ 1.96
Shear resistance F _{v,Rk} Component I - t _I [mm] (Al alloy - R _{m,I} ≥ 165 MPa)	0.50	-	-	0.62	0.62	0.62	0.62	0.62	0.62
	0.70	-	-	0.79	0.79	0.79	0.79	0.79	0.79
	0.80	0.51	0.75	0.87	0.87	0.87	0.87	0.87	0.87
	0.90	0.51	0.75	0.87	0.99	0.99	0.99	0.99	0.99
	1.00	0.51	0.75	0.87	0.99	1.12	1.12	1.12	1.12
	1.20	0.51	0.75	0.87	0.99	1.12	1.39	1.39	1.39
	1.50	0.51	0.75	0.87	0.99	1.12	1.39	1.78	1.78
	≥ 2.00	0.51	0.75	0.87	0.99	1.12	1.39	1.78	1.85

B

Sheet metal combination		Component II – core thickness t _{II} [mm]							
		0.46	0.59	0.71	0.84	0.96	1.21	1.46	≥ 1.96
Shear resistance F _{v,Rk} Component I - t _I [mm] (Al alloy - R _{m,I} ≥ 215 MPa)	0.50	-	-	-	0.80	0.80	0.80	0.80	0.80
	0.70	-	-	-	1.03	1.03	1.03	1.03	1.03
	0.80	0.67	0.86	1.06	1.14	1.14	1.14	1.14	1.14
	0.90	0.67	0.86	1.06	1.29	1.29	1.29	1.29	1.29
	1.00	0.67	0.86	1.06	1.29	1.46	1.46	1.46	1.46
	1.20	0.67	0.86	1.06	1.29	1.46	1.81	1.81	1.81
	1.50	0.67	0.86	1.06	1.29	1.46	1.81	2.32	2.32
	≥ 2.00	0.67	0.86	1.06	1.29	1.46	1.81	2.32	2.41

GESIPA®, G-BULB®, PolyGrip®, BULB-TITE®

Blind rivets: **BT-C ALAL 5,2xL F W**

Annex 27

English translation prepared by DIBt

Geometry

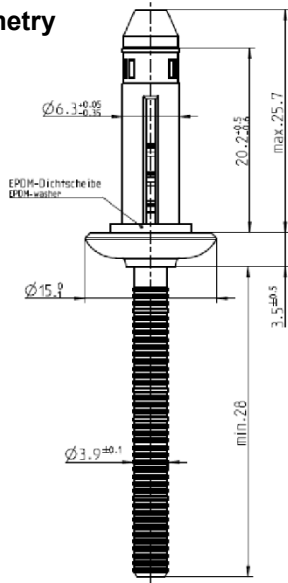

Description of the blind rivet

Material: Body: Aluminium EN AW-5056 [Al Mg5]
Mandrel: Aluminium EN AW-2017 [Al CuMg1]

Conditions for validity of the load capacity values

Component I: EN 10346 – S280GD, S320GD, S350GD
Component II: EN 10346 – S280GD, S320GD, S350GD

Maximum drilling diameter: $d_h \leq 6.6$ mm

Minimum end distance: $e_{1,I} \leq 30$ mm; $e_{1,II} \leq 30$ mm

Minimum edge distance: $e_{2,I} \leq 25$ mm; $e_{2,II} \leq 25$ mm

Nominal load bearable by the blind rivet

Tension: $F_{t,nom} = 2.50$ kN

Shear: $F_{v,nom} = 1.88$ kN

Characteristic resistance for certain joints / combination of minimum sheet thicknesses – [kN]

Sheet metal combination		Component II – core thickness t_{II} [mm]								
		0.36	0.46	0.59	0.71	0.84	0.96	1.21	≥ 1.46	
Tension resistance $F_{j,t,Rk}$	Component I core thickness t_I [mm]	0.36	-	-	-	-	-	-	1.17	1.17
		0.46	-	-	-	-	-	-	1.50	1.50
		0.59	-	-	-	-	-	1.50	1.50	1.50
		0.71	-	-	-	-	-	1.50	1.50	1.50
		0.84	-	-	-	-	1.50	1.50	1.50	1.50
		0.96	-	-	1.41	1.50	1.50	1.50	1.50	1.50
		1.21	0.94 *)	1.21 *)	1.41	1.50	1.50	1.50	1.50	1.50
		≥ 1.46	0.94	1.21	1.41	1.50	1.50	1.50	1.50	1.50
Shear resistance $F_{j,v,Rk}$	Component I core thickness t_I [mm]	0.36	-	-	-	-	-	-	1.32	1.32
		0.46	-	-	-	-	-	-	1.58	1.58
		0.59	-	-	-	-	-	1.90	1.90	1.90
		0.71	-	-	-	-	-	1.90	1.90	1.90
		0.84	-	-	-	-	1.66	1.90	1.90	1.90
		0.96	-	-	1.69	1.69	1.69	1.90	1.90	1.90
		1.21	1.05	1.33	1.69	1.69	1.69	1.90	1.90	1.90
		≥ 1.46	1.05	1.33	1.69	1.69	1.69	1.90	1.90	1.90

*) corresponds to $F_{o,Rk}$ (referred to t_{II})

GESIPA®, G-BULB®, PolyGrip®, BULB-TITE®

Blind rivets: **BT-C ALAL 6,3xL F W**

Annex 28

Geometry

>>> see Annex 28

Description of the blind rivet

>>> see Annex 28

Conditions for validity of the load capacity values

- Component I: Al alloy acc. to EN 573 – $R_{m,I} \geq 165$ MPa **A**
- Al alloy acc. to EN 573 – $R_{m,I} \geq 215$ MPa **B**
- Component II: Al alloy acc. to EN 573 – $R_{m,II} \geq 165$ MPa **A**
- Al alloy acc. to EN 573 – $R_{m,II} \geq 215$ MPa **B**

Maximum drilling diameter: $d_h \leq 6.6$ mm

Minimum end distance: $e_{1,I} \leq 30$ mm; $e_{1,II} \leq 30$ mm

Minimum edge distance: $e_{2,I} \leq 25$ mm; $e_{2,II} \leq 25$ mm

Characteristic pull-out resistance referred to component II– [kN]

		Component II – core thickness t_{II} [mm]							
		Sheet metal	0.50	0.70	0.80	0.90	1.00	1.20	1.50
F_{o,Rk}	A ($R_m \geq 165$ MPa)	0.35	0.61	0.73	0.87	1.02	1.02	1.02	1.02
	B ($R_m \geq 215$ MPa)	0.46	0.79	0.96	1.14	1.33	1.33	1.33	1.33

Characteristic resistance for certain joints / combination of minimum sheet thicknesses – [kN]

A		Sheet metal combination	Component II – core thickness t_{II} [mm] (Al alloy - $R_{m,II} \geq 165$ MPa)							
			0.50	0.70	0.80	0.90	1.00	1.20	1.50	≥ 2.00
Shear resistance F_{j,v,Rk}	Component I - t_I [mm] (Al alloy - $R_{m,I} \geq 165$ MPa)	0.50	-	-	-	-	-	0.91	0.91	0.91
		0.70	-	-	-	-	-	0.91	0.91	0.91
		0.80	-	-	0.86	0.86	0.86	0.91	0.91	0.91
		0.90	-	-	0.86	0.86	0.86	0.91	0.91	0.91
		1.00	-	-	0.86	0.86	0.86	0.91	0.91	0.91
		1.20	0.82	0.85	0.86	0.86	0.86	0.91	0.91	0.91
		1.50	0.82	0.85	0.86	0.86	0.86	0.91	0.91	0.91
		≥ 2.00	0.82	0.85	0.86	0.86	0.86	0.91	0.91	0.91

B		Sheet metal combination	Component II – core thickness t_{II} [mm] (Al alloy - $R_{m,II} \geq 215$ MPa)							
			0.50	0.70	0.80	0.90	1.00	1.20	1.50	≥ 2.00
Shear resistance F_{j,v,Rk}	Component I - t_I [mm] (Al alloy - $R_{m,I} \geq 215$ MPa)	0.50	-	-	-	-	-	1.18	1.18	1.18
		0.70	-	-	-	-	-	1.18	1.18	1.18
		0.80	-	-	1.11	1.13	1.15	1.18	1.18	1.18
		0.90	-	-	1.11	1.13	1.15	1.18	1.18	1.18
		1.00	-	-	1.11	1.13	1.15	1.18	1.18	1.18
		1.20	1.05	1.09	1.11	1.13	1.15	1.18	1.18	1.18
		1.50	1.05	1.09	1.11	1.13	1.15	1.18	1.18	1.18
		≥ 2.00	1.05	1.09	1.11	1.13	1.15	1.18	1.18	1.18

GESIPA®, G-BULB®, PolyGrip®, BULB-TITE®

Blind rivets: **BT-C ALAL 6,3xL F W**

Annex 29

Geometry

>>> see Annex 28

Description of the blind rivet

>>> see Annex 28

Conditions for validity of the load capacity values

Component I: Al alloy acc. to EN 573 – $R_{m,I} \geq 165$ MPa **A**
 Al alloy acc. to EN 573 – $R_{m,I} \geq 215$ MPa **B**
 Component II: EN 10346 – S280GD, S320GD, S350GD
 Maximum drilling diameter: $d_h \leq 6.6$ mm
 Minimum end distance: $e_{1,I} \leq 30$ mm; $e_{1,II} \leq 30$ mm
 Minimum edge distance: $e_{2,I} \leq 25$ mm; $e_{2,II} \leq 25$ mm

Characteristic pull-out resistance referred to component II– [kN]

	Sheet metal	Component II – core thickness t_{II} [mm]							
		0.46	0.59	0.71	0.84	0.96	1.21	1.46	≥ 1.96
$F_{o,Rk}$	S280GD S320GD S350GD	1.21	1.41	1.50	1.50	1.50	1.50	1.50	1.50

Characteristic resistance for certain joints / combination of minimum sheet thicknesses – [kN]

A	Sheet metal combination	Component II – core thickness t_{II} [mm]								
		0.46	0.59	0.71	0.84	0.96	1.21	1.46	≥ 1.96	
Shear resistance $F_{j,v,Rk}$	Component I - t_I [mm] (Al alloy - $R_{m,I} \geq 165$ MPa)	0.50	-	-	-	-	0.91	0.91	0.91	
		0.70	-	-	-	-	0.91	0.91	0.91	
		0.80	-	-	-	0.86	0.86	0.91	0.91	0.91
		0.90	-	-	-	0.86	0.86	0.91	0.91	0.91
		1.00	-	-	0.86	0.86	0.86	0.91	0.91	0.91
		1.20	0.82	0.84	0.86	0.86	0.86	0.91	0.91	0.91
		1.50	0.82	0.84	0.86	0.86	0.86	0.91	0.91	0.91
≥ 2.00	0.82	0.84	0.86	0.86	0.86	0.91	0.91	0.91		

B	Sheet metal combination	Component II – core thickness t_{II} [mm]								
		0.46	0.59	0.71	0.84	0.96	1.21	1.46	≥ 1.96	
Shear resistance $F_{j,v,Rk}$	Component I - t_I [mm] (Al alloy - $R_{m,I} \geq 215$ MPa)	0.50	-	-	-	-	1.18	1.18	1.18	
		0.70	-	-	-	-	1.18	1.18	1.18	
		0.80	-	-	-	1.13	1.15	1.18	1.18	1.18
		0.90	-	-	-	1.13	1.15	1.18	1.18	1.18
		1.00	-	-	1.10	1.13	1.15	1.18	1.18	1.18
		1.20	1.05	1.08	1.10	1.13	1.15	1.18	1.18	1.18
		1.50	1.05	1.08	1.10	1.13	1.15	1.18	1.18	1.18
≥ 2.00	1.05	1.08	1.10	1.13	1.15	1.18	1.18	1.18		

GESIPA®, G-BULB®, PolyGrip®, BULB-TITE®

Blind rivets: **BT-C ALAL 6,3xL F W**

Annex 30

Geometry

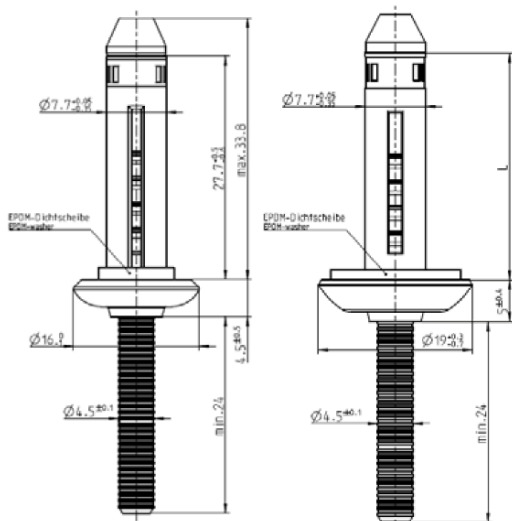

Description of the blind rivet

Material: Body: Aluminium EN AW-5056 [Al Mg5]
Mandrel: Aluminium EN AW-2017 [Al CuMg1]

Conditions for validity of the load capacity values

Component I: EN 10346 – S280GD, S320GD, S350GD
Component II: EN 10346 – S280GD, S320GD, S350GD

Maximum drilling diameter: $d_h \leq 8.2$ mm

Minimum end distance: $e_{1,I} \leq 30$ mm; $e_{1,II} \leq 30$ mm

Minimum edge distance: $e_{2,I} \leq 25$ mm; $e_{2,II} \leq 25$ mm

Nominal load bearable by the blind rivet

Tension: ($F_{t,nom}$ not determined) **Shear:** ($F_{v,nom}$ not determined)

Characteristic resistance for certain joints / combination of minimum sheet thicknesses – [kN]

		Sheet metal combination	Component II – core thickness t_{II} [mm]							
			0.36	0.46	0.59	0.71	0.84	0.96	1.21	≥ 1.46
Tension resistance $F_{t,Rk}$	Component I core thickness t_I [mm]	0.36	-	-	1.24	1.29	1.29	1.29	1.29	1.29
		0.46	-	-	1.24	1.45	1.45	1.45	1.45	1.45
		0.59	0.54 *)	0.85 *)	1.24	1.52	1.62	1.62	1.62	1.62
		0.71	0.54	0.85	1.24	1.52	1.71	2.00	2.00	2.00
		0.84	0.54	0.85	1.24	1.52	1.71	2.00	2.28	2.47
		0.96	0.54	0.85	1.24	1.52	1.71	2.00	2.28	3.90
		1.21	0.54	0.85	1.24	1.52	1.71	2.00	2.28	3.90
		≥ 1.46	0.54	0.85	1.24	1.52	1.71	2.00	2.28	3.90
Shear resistance $F_{v,Rk}$	Component I core thickness t_I [mm]	0.36	-	-	1.31	1.31	1.31	1.31	1.31	1.31
		0.46	-	1.27	1.61	1.61	1.61	1.61	1.61	1.61
		0.59	1.27	1.59	2.00	2.19	2.28	2.28	2.38	2.47
		0.71	1.27	1.59	2.00	2.57	2.66	2.66	2.76	2.76
		0.84	1.27	1.59	2.00	2.57	3.33	4.09	4.09	4.09
		0.96	1.27	1.59	2.00	2.57	3.33	4.18	4.18	4.18
		1.21	1.27	1.59	2.00	2.57	3.33	4.18	4.66	4.66
		≥ 1.46	1.27	1.59	2.00	2.57	3.33	4.18	4.66	5.04

*) corresponds to $F_{o,Rk}$ (referred to t_{II})

GESIPA®, G-BULB®, PolyGrip®, BULB-TITE®

Blind rivets: **BT-C ALAL 7,7xL F W**

Annex 31

English translation prepared by DIBt

Geometry

>>> see Annex 31

Description of the blind rivet

>>> see Annex 31

Conditions for validity of the load capacity values

- Component I: Al alloy acc. to EN 573 – $R_{m,I} \geq 165$ MPa **A**
- Al alloy acc. to EN 573 – $R_{m,I} \geq 215$ MPa **B**
- Component II: Al alloy acc. to EN 573 – $R_{m,II} \geq 165$ MPa **A**
- Al alloy acc. to EN 573 – $R_{m,II} \geq 215$ MPa **B**
- Maximum drilling diameter: $d_h \leq 8.2$ mm
- Minimum end distance: $e_{1,I} \leq 30$ mm; $e_{1,II} \leq 30$ mm
- Minimum edge distance: $e_{2,I} \leq 25$ mm; $e_{2,II} \leq 25$ mm

Characteristic pull-out resistance referred to component II– [kN]

		Component II – core thickness t_{tr} [mm]							
		Sheet metal	0.50	0.70	0.80	0.90	1.00	1.20	1.50
F_{o,Rk}	A ($R_m \geq 165$ MPa)	0.42	0.71	0.86	0.93	1.00	1.00	1.00	1.00
	B ($R_m \geq 215$ MPa)	0.54	0.93	1.12	1.22	1.30	1.30	1.30	1.30

Characteristic resistance for certain joints / combination of minimum sheet thicknesses – [kN]

A		Sheet metal combination	Component II – core thickness t_{tr} [mm] (Al alloy - $R_{m,II} \geq 165$ MPa)							
			0.50	0.70	0.80	0.90	1.00	1.20	1.50	≥ 2.00
Shear resistance F_{j,v,Rk}	Component I - t_r [mm] (Al alloy - $R_{m,I} \geq 165$ MPa)	0.50	0.53	0.53	0.53	0.53	0.53	0.53	0.53	0.53
		0.70	0.53	0.86	0.86	0.86	0.86	0.86	0.86	0.86
		0.80	0.53	0.86	1.03	1.03	1.03	1.03	1.03	1.03
		0.90	0.53	0.86	1.03	1.33	1.33	1.33	1.33	1.33
		1.00	0.53	0.86	1.03	1.33	1.63	1.63	1.63	1.63
		1.20	0.53	0.86	1.03	1.33	1.63	2.23	2.23	2.23
		1.50	0.53	0.86	1.03	1.33	1.63	2.23	2.23	2.23
		≥ 2.00	0.53	0.86	1.03	1.33	1.63	2.23	2.23	2.23

B		Sheet metal combination	Component II – core thickness t_{tr} [mm] (Al alloy - $R_{m,II} \geq 215$ MPa)							
			0.50	0.70	0.80	0.90	1.00	1.20	1.50	≥ 2.00
Shear resistance F_{j,v,Rk}	Component I - t_r [mm] (Al alloy - $R_{m,I} \geq 215$ MPa)	0.50	0.69	0.69	0.69	0.69	0.69	0.69	0.69	0.69
		0.70	0.69	1.12	1.12	1.12	1.12	1.12	1.12	1.12
		0.80	0.69	1.12	1.33	1.33	1.33	1.33	1.33	1.33
		0.90	0.69	1.12	1.33	1.69	1.69	1.69	1.69	1.69
		1.00	0.69	1.12	1.33	1.69	2.06	3.01	3.01	3.01
		1.20	0.69	1.12	1.33	1.69	2.06	2.78	2.78	2.78
		1.50	0.69	1.12	1.33	1.69	2.06	2.78	2.78	2.78
		≥ 2.00	0.69	1.12	1.33	1.69	2.06	2.78	2.78	2.78

GESIPA®, G-BULB®, PolyGrip®, BULB-TITE®

Blind rivets: **BT-C ALAL 7,7xL F W**

Annex 32

English translation prepared by DIBt

Geometry

>>> see Annex 31

Description of the blind rivet

>>> see Annex 31

Conditions for validity of the load capacity values

Component I: Al alloy acc. to EN 573 – $R_{m,I} \geq 165$ MPa **A**
Al alloy acc. to EN 573 – $R_{m,I} \geq 215$ MPa **B**

Component II: EN 10346 – S280GD, S320GD, S350GD

Maximum drilling diameter: $d_h \leq 8.2$ mm

Minimum end distance: $e_{1,I} \leq 30$ mm; $e_{1,II} \leq 30$ mm

Minimum edge distance: $e_{2,I} \leq 25$ mm; $e_{2,II} \leq 25$ mm

Characteristic pull-out resistance referred to component II– [kN]

$F_{o,Rk}$	Sheet metal	Component II – core thickness t_{II} [mm]							
		0.46	0.59	0.71	0.84	0.96	1.21	1.46	≥ 1.96
	S280GD S320GD S350GD	0.85	1.24	1.52	1.71	2.00	2.76	3.90	3.90

Characteristic resistance for certain joints / combination of minimum sheet thicknesses – [kN]

A	Sheet metal combination	Component II – core thickness t_{II} [mm]								
		0.46	0.59	0.71	0.84	0.96	1.21	1.46	≥ 1.96	
Shear resistance $F_{s,Rk}$	Component I - t_I [mm] (Al alloy - $R_{m,I} \geq 165$ MPa)	0.50	0.53	0.53	0.53	0.53	0.53	0.53	0.53	0.53
		0.70	0.53	0.75	0.86	0.86	0.86	0.86	0.86	0.86
		0.80	0.53	0.75	0.95	1.03	1.03	1.03	1.03	1.03
		0.90	0.53	0.75	0.95	1.30	1.33	1.33	1.33	1.33
		1.00	0.53	0.75	0.95	1.30	1.63	1.63	1.63	1.63
		1.20	0.53	0.75	0.95	1.30	1.63	2.23	2.23	2.23
		≥ 2.00	0.53	0.75	0.95	1.30	1.63	2.23	2.23	2.23

B	Sheet metal combination	Component II – core thickness t_{II} [mm]								
		0.46	0.59	0.71	0.84	0.96	1.21	1.46	≥ 1.96	
Shear resistance $F_{s,Rk}$	Component I - t_I [mm] (Al alloy - $R_{m,I} \geq 215$ MPa)	0.50	0.69	0.69	0.69	0.69	0.69	0.69	0.69	0.69
		0.70	0.69	0.97	1.12	1.12	1.12	1.12	1.12	1.12
		0.80	0.69	0.97	1.23	1.33	1.33	1.33	1.33	1.33
		0.90	0.69	0.97	1.23	1.62	1.69	1.69	1.69	1.69
		1.00	0.69	0.97	1.23	1.62	2.06	2.06	2.06	2.06
		1.20	0.69	0.97	1.23	1.62	2.06	2.78	2.78	2.78
		1.50	0.69	0.97	1.23	1.62	2.06	2.78	2.78	2.78
≥ 2.00	0.69	0.97	1.23	1.62	2.06	2.78	2.78	2.78		

GESIPA®, G-BULB®, PolyGrip®, BULB-TITE®

Blind rivets: **BT-C ALAL 7,7xL F W**

Annex 33

English translation prepared by DIBt

Geometry

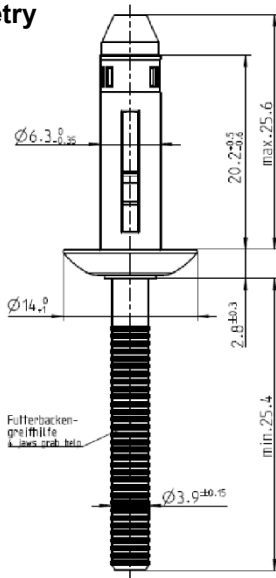

Description of the blind rivet

Material: Body: Ni-Cu-Alloy DIN 17743 - 2.4360 [NiCu30Fe]
Mandrel: Stainless Steel EN 10088-5 – 1.4567

Conditions for validity of the load capacity values

Component I: EN 10346 – S280GD, S320GD, S350GD

Component II: EN 10346 – S280GD, S320GD, S350GD

Maximum drilling diameter: $d_h \leq 6.6$ mm

Minimum end distance: $e_{1,I} \leq 30$ mm; $e_{1,II} \leq 30$ mm

Minimum edge distance: $e_{2,I} \leq 25$ mm; $e_{2,II} \leq 25$ mm

Nominal load bearable by the blind rivet

Tension: ($F_{t,nom}$ not determined) **Shear:** $F_{v,nom} = 4.62$ kN

Characteristic resistance for certain joints / combination of minimum sheet thicknesses – [kN]

	Sheet metal combination	Component II – core thickness t_{II} [mm]								
		0.36	0.46	0.59	0.71	0.84	0.96	1.21	≥ 1.46	
Tension resistance $F_{t,Rk}$	Component I core thickness t_I [mm]	0.36	-	-	-	-	-	-	1.35	1.35
		0.46	-	-	-	-	-	-	1.75	1.75
		0.59	-	-	-	-	-	1.75	1.75	1.75
		0.71	-	-	-	-	-	1.75	1.75	1.75
		0.84	-	-	-	-	1.75	1.75	1.75	1.75
		0.96	-	-	1.26 *)	1.75 *)	1.75	1.75	1.75	1.75
		1.21	0.51 *)	0.74 *)	1.26	1.75	1.75	1.75	1.75	1.75
		≥ 1.46	0.51	0.74	1.26	1.75	1.75	1.75	1.75	1.75
Shear resistance $F_{j,v,Rk}$	Component I core thickness t_I [mm]	0.36	-	-	-	-	-	-	1.43	1.43
		0.46	-	-	-	-	-	-	2.04	2.04
		0.59	-	-	-	-	-	2.84	2.84	2.84
		0.71	-	-	-	-	-	2.94	2.94	2.94
		0.84	-	-	-	-	3.03	3.03	3.03	3.03
		0.96	-	-	2.43	2.72	3.03	3.03	3.03	3.03
		1.21	1.27	1.78	2.43	2.72	3.03	3.03	3.03	3.03
		≥ 1.46	1.27	1.78	2.43	2.72	3.03	3.03	3.03	3.03

*) corresponds to $F_{o,Rk}$ (referred to t_{II})

GESIPA®, G-BULB®, PolyGrip®, BULB-TITE®

Blind rivets: **BT-C MOA2 6,3xL RK**

Annex 34

Geometry

>>> see Annex 34

Description of the blind rivet

>>> see Annex 34

Conditions for validity of the load capacity values

- Component I: Al alloy acc. to EN 573 – $R_{m,I} \geq 165$ MPa **A**
- Al alloy acc. to EN 573 – $R_{m,I} \geq 215$ MPa **B**
- Component II: Al alloy acc. to EN 573 – $R_{m,II} \geq 165$ MPa **A**
- Al alloy acc. to EN 573 – $R_{m,II} \geq 215$ MPa **B**

Maximum drilling diameter: $d_h \leq 6.6$ mm

Minimum end distance: $e_{1,I} \leq 30$ mm; $e_{1,II} \leq 30$ mm

Minimum edge distance: $e_{2,I} \leq 25$ mm; $e_{2,II} \leq 25$ mm

Characteristic pull-out resistance referred to component II– [kN]

Sheet metal		Component II – core thickness t_{II} [mm]							
		0.50	0.70	0.80	0.90	1.00	1.20	1.50	≥ 2.00
F_{o,Rk}	A ($R_m \geq 165$ MPa)	0.23	0.40	0.48	0.58	0.67	0.67	0.67	0.67
	B ($R_m \geq 215$ MPa)	0.29	0.51	0.63	0.75	0.87	0.87	0.87	0.87

Characteristic resistance for certain joints / combination of minimum sheet thicknesses – [kN]

A	Sheet metal combination	Component II – core thickness t_{II} [mm] (Al alloy - $R_{m,II} \geq 165$ MPa)								
		0.50	0.70	0.80	0.90	1.00	1.20	1.50	≥ 2.00	
Shear resistance F_{j,v,Rk}	Component I - t_I [mm] (Al alloy - $R_{m,I} \geq 165$ MPa)	0.50	-	-	-	-	-	0.98	0.98	0.98
		0.70	-	-	-	-	-	1.26	1.26	1.26
		0.80	-	-	1.41	1.41	1.41	1.41	1.41	1.41
		0.90	-	-	1.41	1.41	1.41	1.41	1.41	1.41
		1.00	-	-	1.41	1.41	1.41	1.41	1.41	1.41
		1.20	0.90	1.24	1.41	1.41	1.41	1.41	1.41	1.41
		1.50	0.90	1.24	1.41	1.41	1.41	1.41	1.41	1.41
		≥ 2.00	0.90	1.24	1.41	1.41	1.41	1.41	1.41	1.41

B	Sheet metal combination	Component II – core thickness t_{II} [mm] (Al alloy - $R_{m,II} \geq 215$ MPa)								
		0.50	0.70	0.80	0.90	1.00	1.20	1.50	≥ 2.00	
Shear resistance F_{j,v,Rk}	Component I - t_I [mm] (Al alloy - $R_{m,I} \geq 215$ MPa)	0.50	-	-	-	-	-	1.27	1.27	1.27
		0.70	-	-	-	-	-	1.64	1.64	1.64
		0.80	-	-	1.82	1.82	1.82	1.82	1.82	1.82
		0.90	-	-	1.82	1.82	1.82	1.82	1.82	1.82
		1.00	-	-	1.82	1.82	1.82	1.82	1.82	1.82
		1.20	1.18	1.61	1.82	1.82	1.82	1.82	1.82	1.82
		1.50	1.18	1.61	1.82	1.82	1.82	1.82	1.82	1.82
		≥ 2.00	1.18	1.61	1.82	1.82	1.82	1.82	1.82	1.82

GESIPA®, G-BULB®, PolyGrip®, BULB-TITE®

Blind rivets: **BT-C MOA2 6,3xL RK**

Annex 35

Geometry

>>> see Annex 34

Description of the blind rivet

>>> see Annex 34

Conditions for validity of the load capacity values

Component I: Al alloy acc. to EN 573 – $R_{m,I} \geq 165$ MPa

A

Al alloy acc. to EN 573 – $R_{m,I} \geq 215$ MPa

B

Component II: EN 10346 – S280GD, S320GD, S350GD

Maximum drilling diameter: $d_h \leq 6.6$ mm

Minimum end distance: $e_{1,I} \leq 30$ mm; $e_{1,II} \leq 30$ mm

Minimum edge distance: $e_{2,I} \leq 25$ mm; $e_{2,II} \leq 25$ mm

Characteristic pull-out resistance referred to component II– [kN]

	Sheet metal	Component II – core thickness t_{II} [mm]							
		0.46	0.59	0.71	0.84	0.96	1.21	1.46	≥ 1.96
$F_{o,Rk}$	S280GD S320GD S350GD	0.74	1.26	1.75	1.75	1.75	1.75	1.75	1.75

Characteristic resistance for certain joints / combination of minimum sheet thicknesses – [kN]

A	Sheet metal combination	Component II – core thickness t_{II} [mm]							
		0.46	0.59	0.71	0.84	0.96	1.21	1.46	≥ 1.96
Shear resistance $F_{j,v,Rk}$	Component I - t_I [mm] (Al alloy - $R_{m,I} \geq 165$ MPa)	0.50	-	-	-	-	0.98	0.98	0.98
		0.70	-	-	-	-	1.26	1.26	1.26
		0.80	-	-	-	1.41	1.41	1.41	1.41
		0.90	-	-	-	1.41	1.41	1.41	1.41
		1.00	-	-	-	1.41	1.41	1.41	1.41
		1.20	0.90	1.12	1.32	1.41	1.41	1.41	1.41
		1.50	0.90	1.12	1.32	1.41	1.41	1.41	1.41
		≥ 2.00	0.90	1.12	1.32	1.41	1.41	1.41	1.41

B	Sheet metal combination	Component II – core thickness t_{II} [mm]							
		0.46	0.59	0.71	0.84	0.96	1.21	1.46	≥ 1.96
Shear resistance $F_{j,v,Rk}$	Component I - t_I [mm] (Al alloy - $R_{m,I} \geq 215$ MPa)	0.50	-	-	-	-	1.27	1.27	1.27
		0.70	-	-	-	-	1.64	1.64	1.64
		0.80	-	-	-	1.82	1.82	1.82	1.82
		0.90	-	-	-	1.82	1.82	1.82	1.82
		1.00	-	-	-	1.82	1.82	1.82	1.82
		1.20	1.18	1.45	1.72	1.82	1.82	1.82	1.82
		1.50	1.18	1.45	1.72	1.82	1.82	1.82	1.82
		≥ 2.00	1.18	1.45	1.72	1.82	1.82	1.82	1.82

GESIPA®, G-BULB®, PolyGrip®, BULB-TITE®

Blind rivets: **BT-C MOA2 6,3xL RK**

Annex 36