

Approval body for construction products
and types of construction

Bautechnisches Prüfamt

An institution established by the Federal and
Laender Governments



European Technical Assessment

ETA-16/0852
of 22 June 2022

English translation prepared by DIBt - Original version in German language

General Part

Technical Assessment Body issuing the
European Technical Assessment:

Deutsches Institut für Bautechnik

Trade name of the construction product

BR 100 EU

Product family
to which the construction product belongs

Kit for closure systems for conveyor systems

Manufacturer

gte Brandschutz GmbH
Seestraße 10
14974 Ludwigsfelde
DEUTSCHLAND

Manufacturing plant

Stöbich Brandschutz GmbH
Pracherstieg 6
38644 Goslar
DEUTSCHLAND

This European Technical Assessment
contains

14 pages including 7 annexes which form an integral part
of this assessment

This European Technical Assessment is
issued in accordance with Regulation (EU)
No 305/2011, on the basis of

EAD 350022-01-1107

This version replaces

ETA-16/0852 issued on 3 August 2018

The European Technical Assessment is issued by the Technical Assessment Body in its official language. Translations of this European Technical Assessment in other languages shall fully correspond to the original issued document and shall be identified as such.

Communication of this European Technical Assessment, including transmission by electronic means, shall be in full. However, partial reproduction may only be made with the written consent of the issuing Technical Assessment Body. Any partial reproduction shall be identified as such.

This European Technical Assessment may be withdrawn by the issuing Technical Assessment Body, in particular pursuant to information by the Commission in accordance with Article 25(3) of Regulation (EU) No 305/2011.

Specific Part

1 Technical description of the product

This European Technical Assessment applies for the closure system "BR 100 EU" for conveyor systems, hereinafter referred to as "BR 100 EU". The closure system can be designed to close vertically or horizontally. "BR 100 EU" primarily consists of the following components¹:

– Single-leaf sliding leaf

The approx. 58 mm thick sliding leaf consists of an inner framework of steel hollow profiles (40 mm x 40 mm x 2 mm), filled with a 40 mm thick calcium silicate board and both-sided covered with a 9 mm thick calcium silicate board. The sliding leaf may be covered with ≤ 1 mm thick steel plate. The calcium silicate boards are secured with water glass adhesive and steel cramps.

The sidewise depth of coverage of sliding leaf and wall amount to 110 mm (vertical closing) and 100 mm (horizontal closing). The upper depth of coverage of sliding leaf and wall amount to 90 mm (vertical closing) and 120 mm (horizontal closing).

In the case of a continuous conveyor system, a sealing element consisting of several strips of adhesively bonded and steel clamped calcium silicate board is mounted at the closing edge of the sliding leaf.

– Fixed panel with clearance for the conveyor

The 170 mm thick fixed panel consists of several calcium silicate boards or gypsum boards which are secured with water glass adhesive. The fixed panel is secured to the wall via brackets. The clearance in the fixed panel is configured for the respective conveyor technology. Various intumescent materials are used in the necessary functional gaps.

– Guide for the sliding leaf

The guiding rails, running gears, running rails and wall fastenings have to be dimensioned according to dimension and weight of the sliding leaf. They must comply with the declarations of the drawings of the control plan¹ at least.

– Vertical closing

Guide elements secured at the side of the sliding leaf grip a U-profile (2 mm) secured to the wall. If the clear width of the closure is greater than 2000 mm a grip plate secured on the top of the sliding leaf is necessary (see annex 1, 2 and 4).

Closures, which are closing from bottom to top, have to be provided with a thermal-causing locking device.

– Horizontal closing

The sliding leaf is suspended from the running rail by two running gears. The rail is secured to the wall using brackets. For lower guidance guide roller or guide plates are located at the bottom line of the closure (see annex 3 and 5).

If the clear height of the closure is greater than 2000 mm a grip plate secured on the side of the sliding leaf is necessary (see annex 3).

¹ The documents describing the structure of "BR 100 EU" in detail and the product specifications of the building materials used are deposited with DIBt.

– Seal system

In the overlap of the sliding leaf and adjacent wall on the side of the sliding leaf facing the wall additional strips of calcium silicate boards with strips of an intumescent material are positioned (see annex 4 and 5).

At the closing edge of the sliding leaf a sealing element comprising strips of an intumescent material is mounted. Strips of an intumescent material are also mounted on the fixed panel in the area of the conveyor system (see annex 6).

The sealing elements on the sliding leaf consist of several strips of calcium silicate board.

– Closing device (closing weight system)

"BR 100 EU" shall be closed via stored mechanical energy (closing weight system, deadweight of the sliding leaf).

2 Specification of the intended use in accordance with the applicable European Assessment Document

In accordance with this European Technical Assessment, the "BR 100 EU" was assessed as closure to seal necessary openings of trackbound conveyors (see table 2) in internal walls (see table 1).

When the intumescent materials¹ are used, the verified ambient conditions (e.g. the category stated in TR024²) are to be observed.

"BR 100 EU" is not intended for passenger transportation. The normal position of the closure shall be opened or closed.

The "BR 100 EU" shall only be used if the following conditions apply:

- The normally-open closure (open in the normal position; closes in the event of a fire) shall be equipped with a hold-open system suitable for the closure – where applicable in conjunction with the national regulations.
- The normally-open closure, which cannot be opened from a fixed position (floor, pedestal etc.), is to be equipped with a drive to open the closure.
- It is to be ensured that the closing of the closure is not obstructed by conveyed goods or other objects.
- It is to be ensured that the closed closure cannot be damaged by conveyed goods or other objects.

The verifications and assessment methods on which this European Technical Assessment is based lead to the assumption of a working life of the "BR 100 EU" of at least 10 years. The indications given on the working life cannot be interpreted as a guarantee given by the producer, but are to be regarded only as a means for choosing the right products in relation to the expected economically reasonable working life of the works.

² TR024: Characterization, Aspects of Durability and Factory Production Control for Reactive Materials, Components and Products

Table 1: Permitted dimensions of the clearance of the component opening

component (supporting construction) in which the closure can be installed ^{a)}	maximum fire resistance class ^{b)}	clearance of the wall opening		
		clear width [mm]	clear height [mm]	maximum surface (direction of closing)
high-density solid wall masonry or solid concrete with an overall density of $\geq 800 \text{ kg/m}^3$ and a thickness $\geq 200 \text{ mm}$	E 120 EI ₂ 90 EW 60	min. 500 max. 5.400	min. 500 max. 5.250	16,0 m ² (vertical) 18,9 m ² (horizontal)
a) Supporting construction to EN 1366-7 ³ , section 7.2 or EN 1363-1 ⁴ , section 7.2				
b) Fire resistance class per EN 13501-2 ⁵ in accordance with the Evaluation Report				

Table 2: Permitted sealing systems for the continuous conveyor technology⁶

sealing system for	fixed panel thickness (gypsum cardboard)	minimum depth of the seal on the fixed panel (sealing via calcium silicate boards)	minimum depth of the sealing on the sliding leaf	maximum fire resistance class of BR 100 EU
roll conveyor	170 mm	170 mm Between the rollers: 2 x 20 mm webs	133 mm	EI 90
belt conveyor	170 mm	170 mm	133 mm	EI 120
chain conveyor	170 mm	170 mm	133 mm	EI 120

The conveyor tracks shall be positioned at the bottom and can be continuous or disconnected or disconnected while closing of the closure in the closing area of the sliding leaf.

NOTE: Other requirements and other EU Directives may be applicable to the product(s) falling within the scope of this document.

- 3 EN 1366-7:2004 Fire resistance tests for service installations - Part 7: Conveyor systems and their closures
- 4 EN 1363-1:1999 Fire resistance tests - Part 1: General requirements
- 5 EN 13501-2:2007 Fire classification of construction products and building elements - Part 2: Classification using data from fire resistance tests, excluding ventilation services
- 6 see Annex 6

3 Performance of the product and references to the methods used for its assessment

3.1 Safety in case of fire (BWR 2)

essential characteristic	performance
fire resistance (EN 13501-2)	see clause 2, table 1 and 2
mechanical durability of self-closing (EN 13501-2)	– vertical closing: C5 – horizontal closing: C4
reaction to fire (EN 13501-1)	see following table 3

Table 3: reaction to fire of the used materials

component	material	class in accordance with EN 13501-1
slider leaf, fixed panel	steel sheet	A1
	calzium silicate boards	A1
	gypsum boards	A1
	steel hollow profiles	A1
	water glass adhesive	at least class E
guide	steel	A1
Seal system	intumescent material – Promaseal PL	at least class E
closing device	steel	A1
fixing material	steel	A1

3.2 Hygiene, health and the environment (BWR 3)

essential characteristic	performance
content of dangerous substances	
flame retardants	The product does not contain halogenated aromatic compounds or organophosphorus compounds
release scenarios regarding BWR 3 in accordance with EOTA TR 034: IA1	

4 Assessment and verification of constancy of performance (AVCP) system applied, with reference to its legal base

In accordance with EAD No. 350022-00-1107, the applicable European legal act is: 1999/454/EG.

The system to be applied is: 1

In addition, with regard to reaction to fire of the components/materials for products covered by this EAD the applicable European legal act is: 1999/454/EG.

The systems to be applied are: 1 / 3 / 4 (dependent on classes of reaction to fire)

5 Technical details necessary for the implementation of the AVCP system, as provided for in the applicable EAD

Technical details necessary for the implementation of the AVCP system are laid down in the control plan deposited with Deutsches Institut für Bautechnik.

The manufacturer shall provide installation instructions and maintenance instructions for every "BR 100 EU". The maintenance instructions shall clearly indicate which work is to be performed to ensure that the installed closure system continues to perform its task after long-term use.

The manufacturer shall provide instructions on processing, packaging, transport, storage and use, maintenance and repair of the construction product.

Issued in Berlin on 22 June 2022 Deutsches Institut für Bautechnik

Sylvia Panneck
Head of Section

beglaubigt:
Biedermann

English translation prepared by DIBt

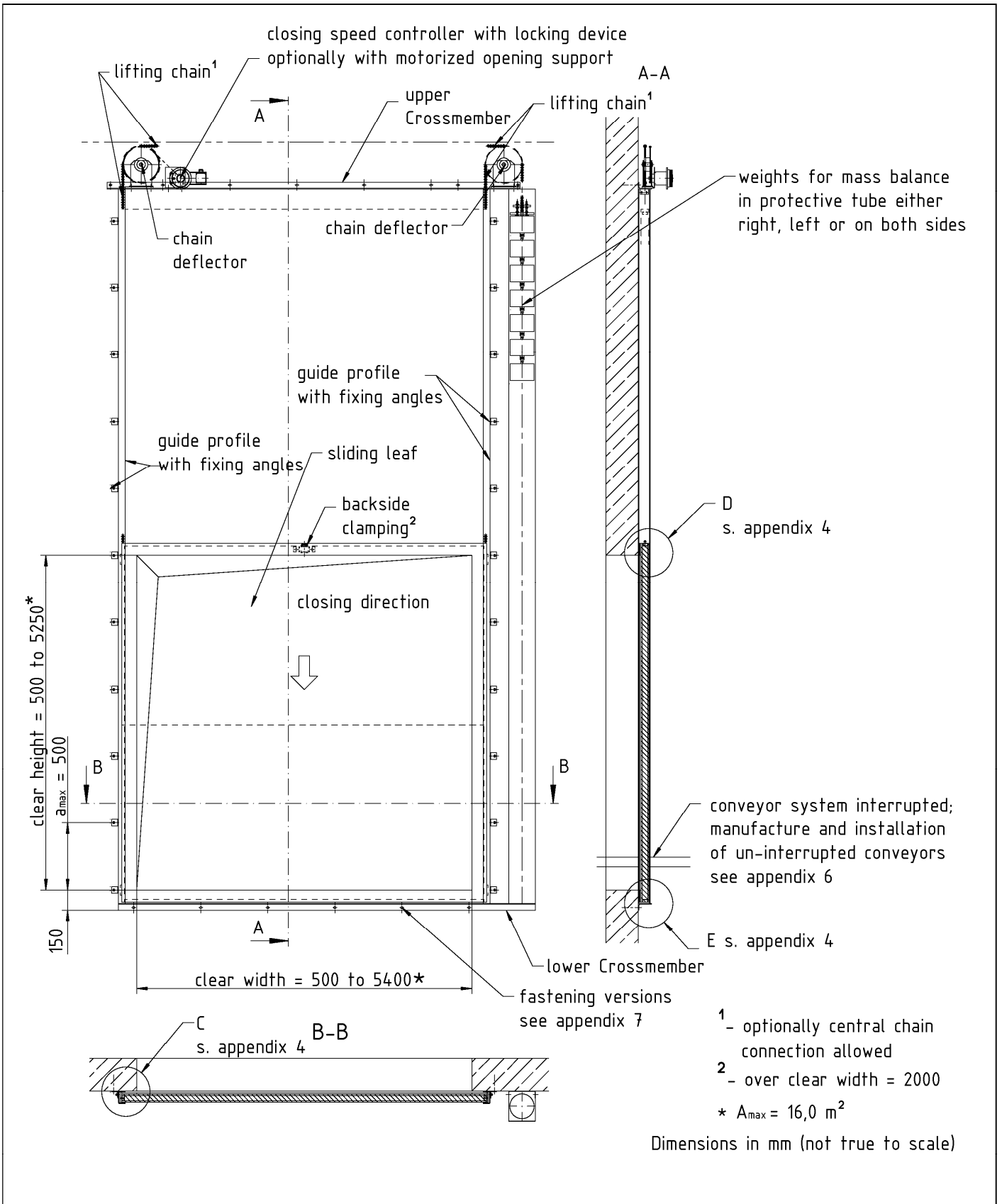

Electronic copy of the ETA by DIBt: ETA-16/0852

BR 100 EU	Annex 1
Closing direction vertically from top to down - Outline	

English translation prepared by DIBt

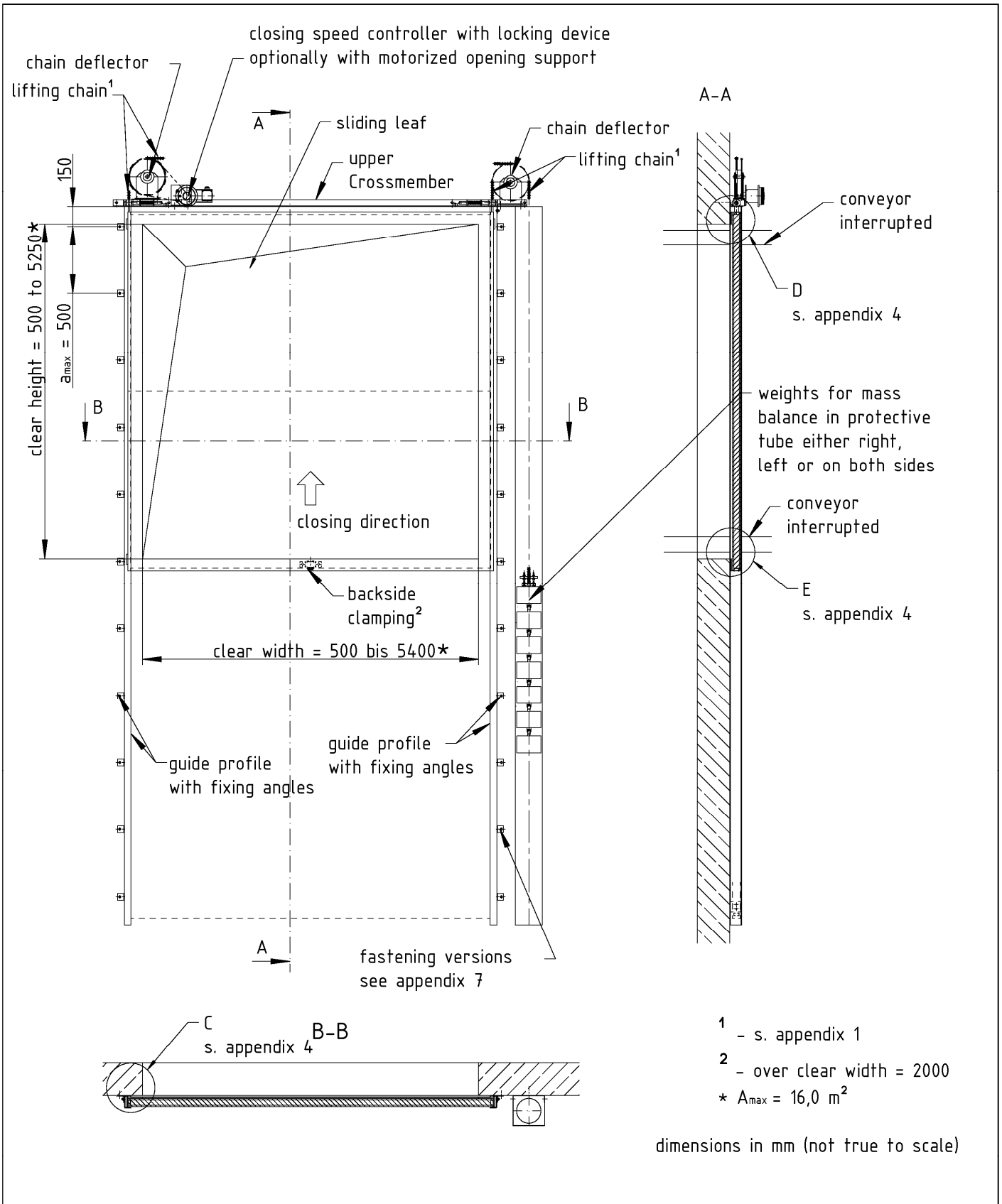

Electronic copy of the ETA by DIBt: ETA-16/0852

BR 100 EU	Annex 2
Closing direction vertically from bottom up - outline	

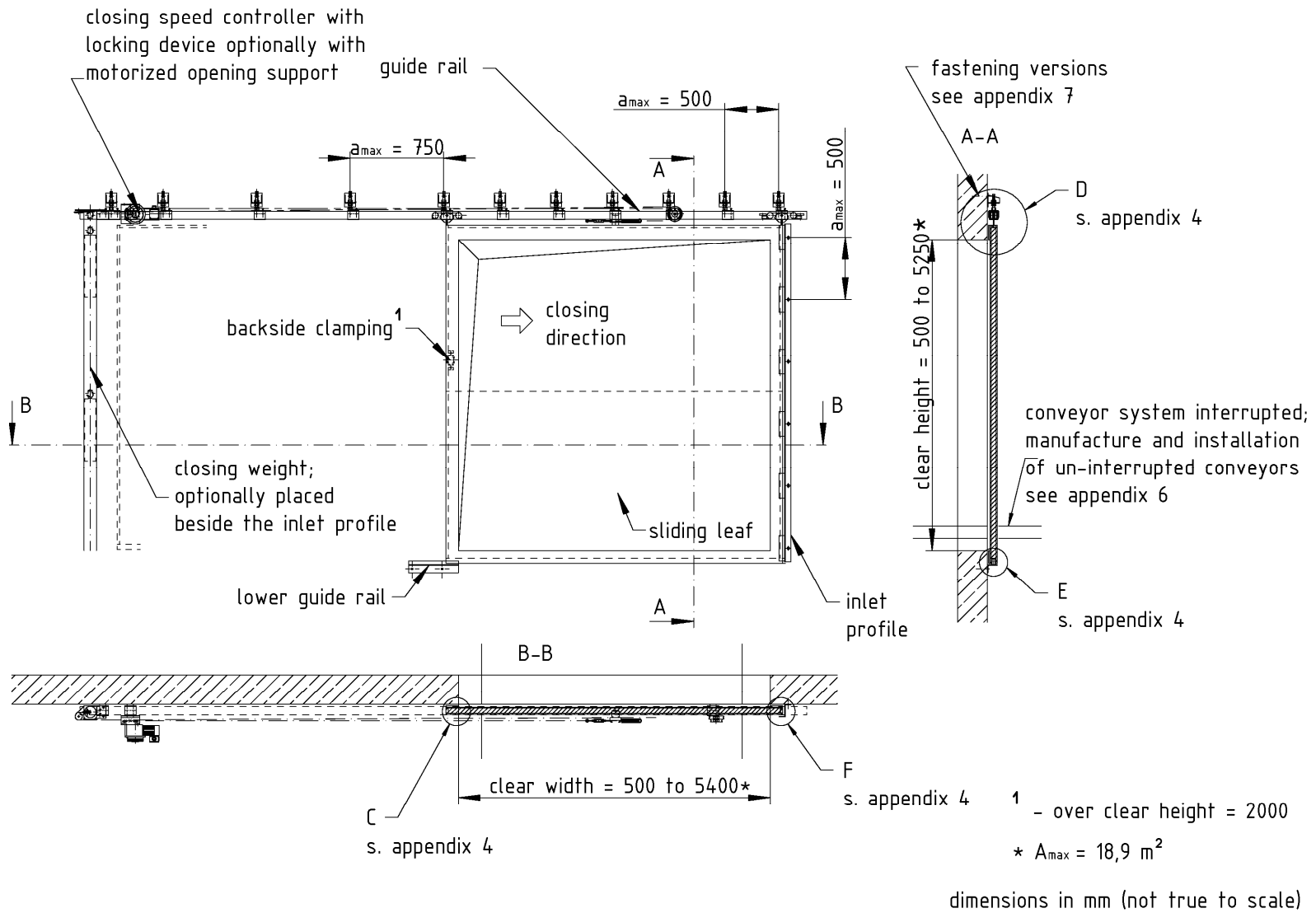

BR 100 EU

Closing direction horizontally - outline

Annex 3

Z36651.22

8.11.07-10/22

English translation prepared by DIBt

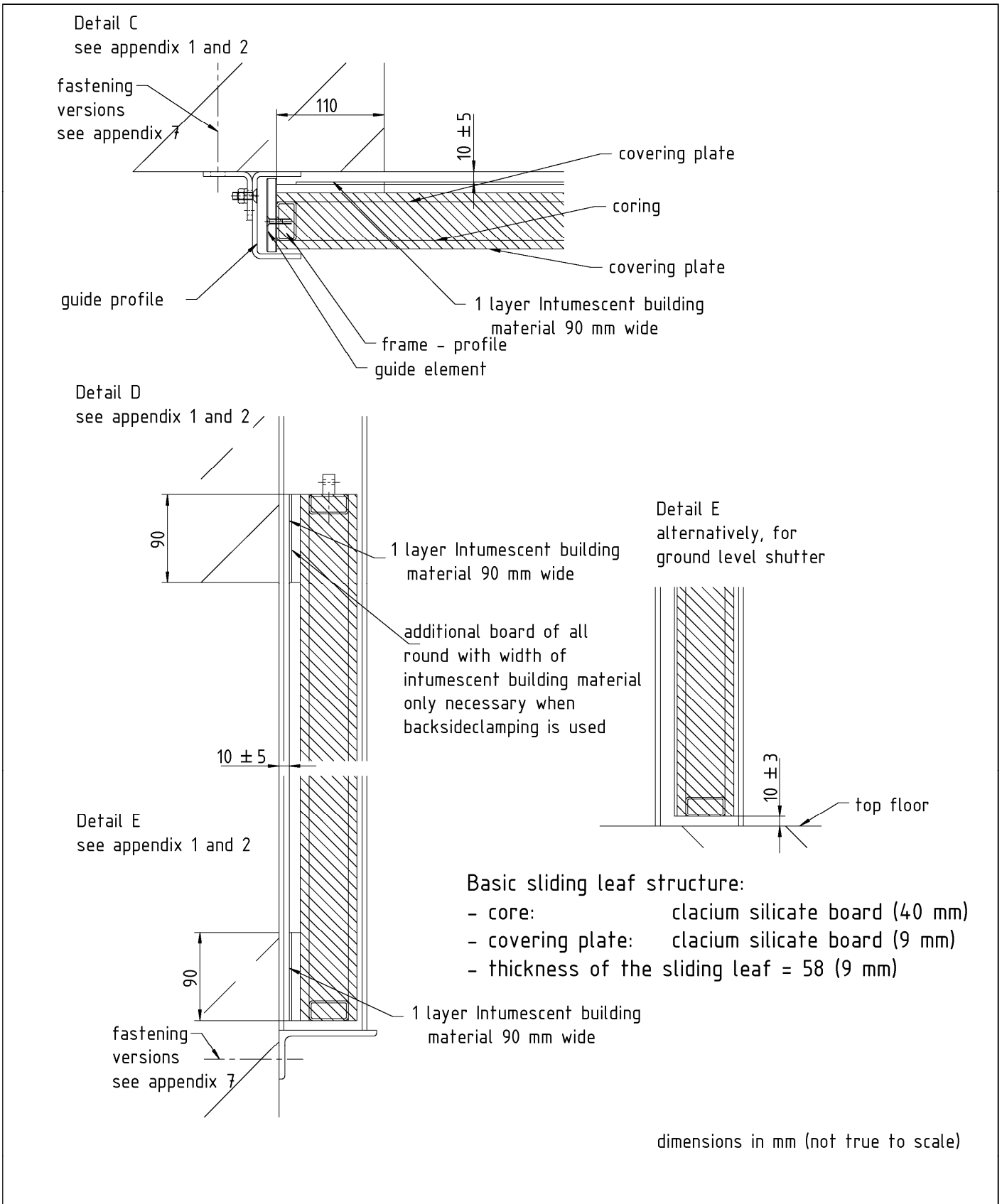

dimensions in mm (not true to scale)

Electronic copy of the ETA by DIBt: ETA-16/0852

BR 100 EU	Annex 4
Closing direction vertically Detailed description of sealing of wall opening	

English translation prepared by DIBt

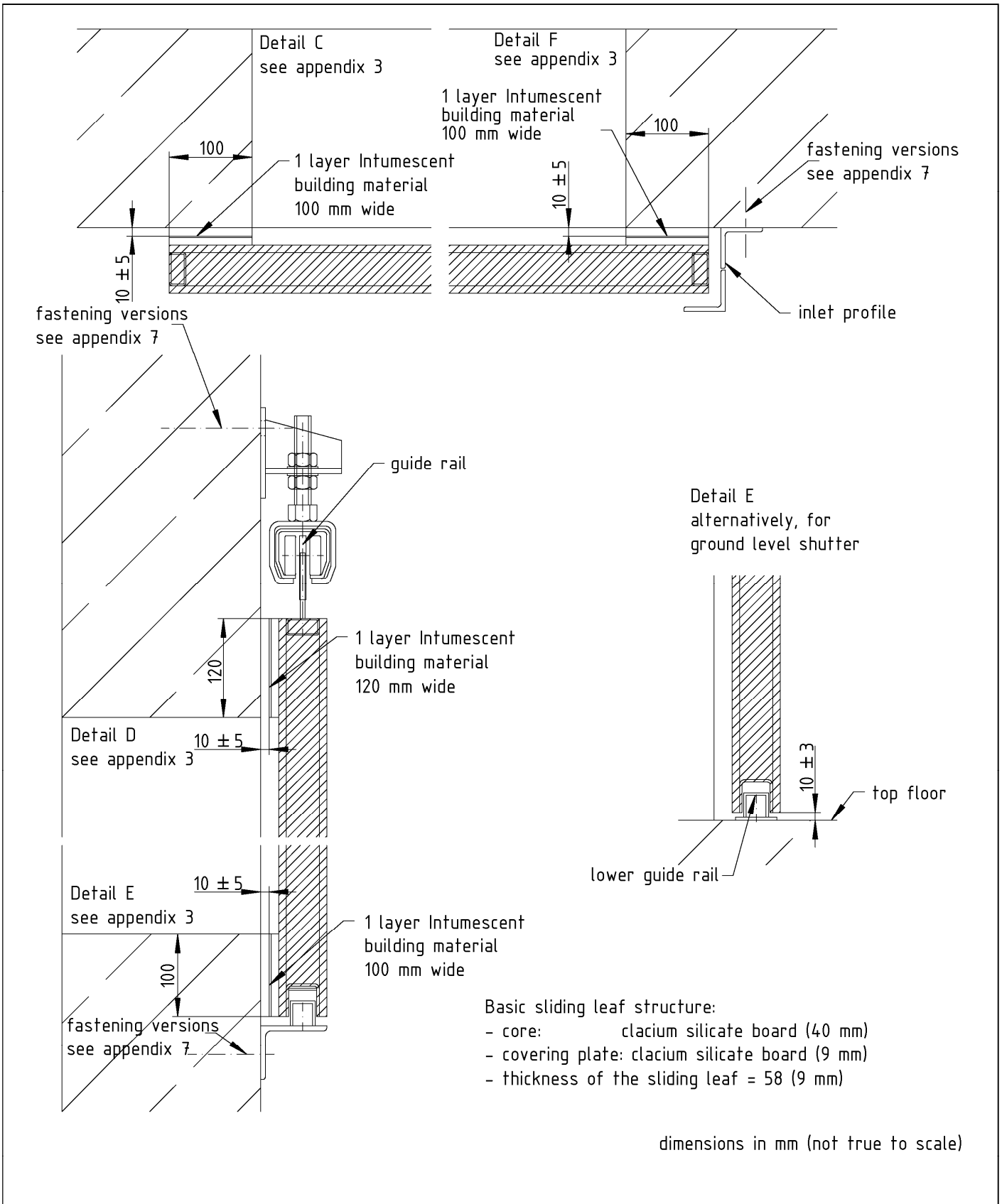

Electronic copy of the ETA by DIBt: ETA-16/0852

BR 100 EU	Annex 5
Closing direction horizontally Detailed description of sealing of wall opening	

English translation prepared by DIBt

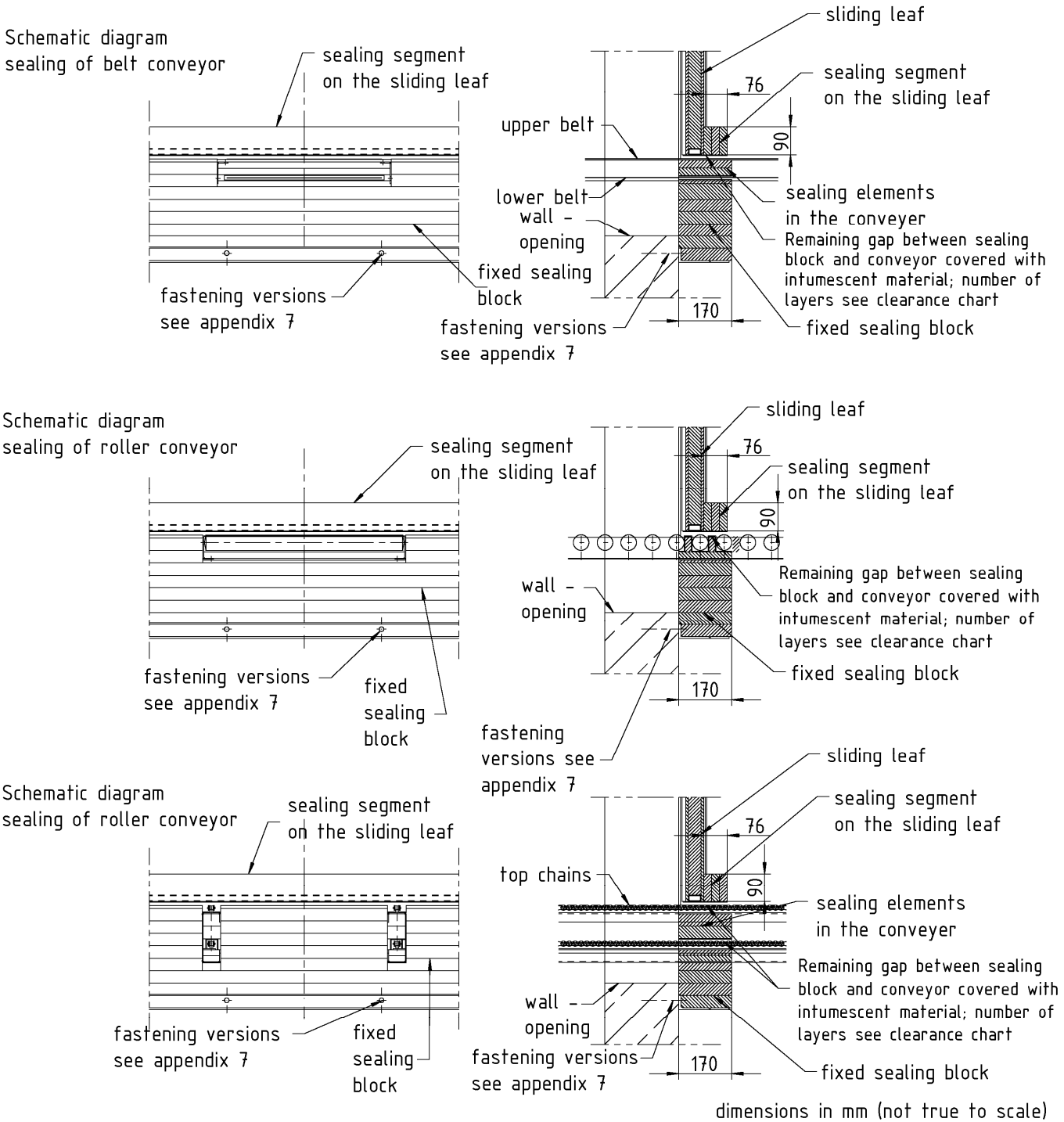

dimensions in mm (not true to scale)

clearance for remaining gaps between the continuous parts of the conveyor and the closure (application of intumescent material PROMASEAL-PL; thickness per layer; 2,5 mm)	
remaining gap (mm)	minum number of layers
10 bis 15	1 layer
16 bis 30	2 layers
31 bis 45	3 layers
Attention: The remaining gaps should be implemented as small as possible	

BR 100 EU

Closing direction vertically from top down and horizontally
Detailed description of the fixed panel with clearance for the conveyor

Annex 6

manner of fastening

- type 1

concrete walls, min. 200 mm thick masonry
(solid walls with high density), min. 200 mm thick

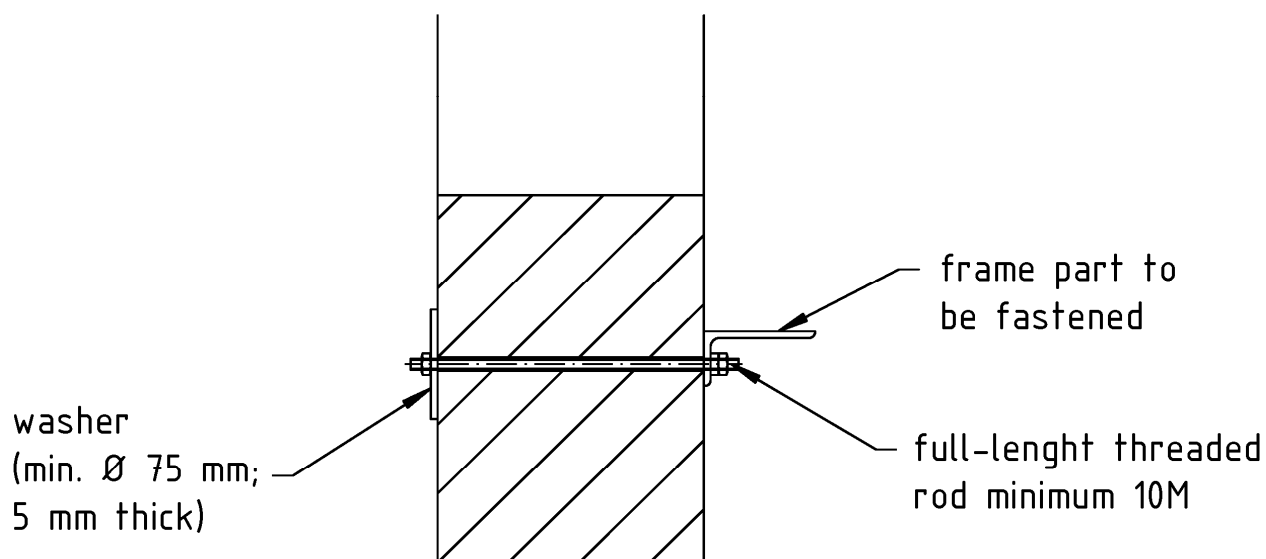

- type 2

concrete walls, min. 200 mm thick
metal dowel with
ETA considering
TR 020

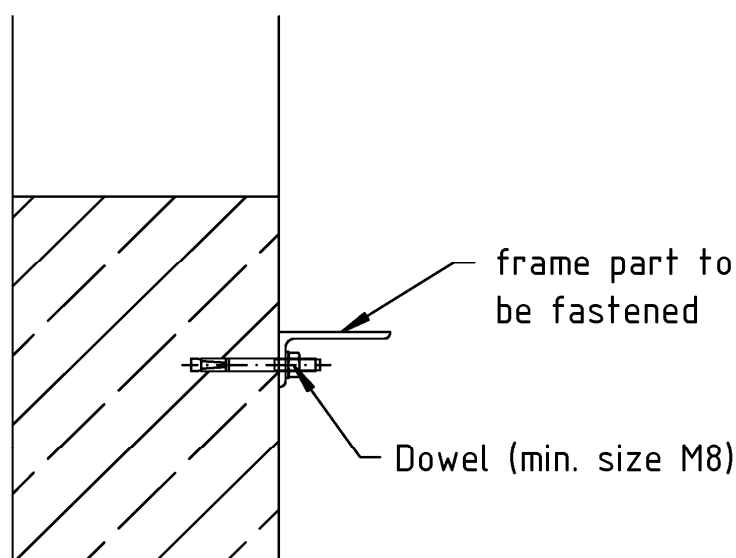

Electronic copy of the ETA by DIBt: ETA-16/0852

BR 100 EU	Annex 7
Manner of fastening	