

Approval body for construction products
and types of construction

Bautechnisches Prüfamt

An institution established by the Federal and
Laender Governments



European Technical Assessment

ETA-18/0297
of 22 June 2022

English translation prepared by DIBt - Original version in German language

General Part

Technical Assessment Body issuing the
European Technical Assessment:

Deutsches Institut für Bautechnik

Trade name of the construction product

BR 104 EU

Product family
to which the construction product belongs

Kit for closure systems for conveyor systems

Manufacturer

gte Brandschutz GmbH
Seestraße 10
14974 Ludwigsfelde
DEUTSCHLAND

Manufacturing plant

Stöbich Brandschutz GmbH
Pracherstieg 6
38644 Goslar
DEUTSCHLAND

This European Technical Assessment
contains

11 pages including 5 annexes which form an integral part
of this assessment

This European Technical Assessment is
issued in accordance with Regulation (EU)
No 305/2011, on the basis of

EAD 350022-01-1107

This version replaces

ETA-18/0297 issued on 16 May 2018

The European Technical Assessment is issued by the Technical Assessment Body in its official language. Translations of this European Technical Assessment in other languages shall fully correspond to the original issued document and shall be identified as such.

Communication of this European Technical Assessment, including transmission by electronic means, shall be in full. However, partial reproduction may only be made with the written consent of the issuing Technical Assessment Body. Any partial reproduction shall be identified as such.

This European Technical Assessment may be withdrawn by the issuing Technical Assessment Body, in particular pursuant to information by the Commission in accordance with Article 25(3) of Regulation (EU) No 305/2011.

Specific Part

1 Technical description of the product

This European Technical Approval applies for the closure system "BR 104 EU" as hanging flap (hinges located at the top) for conveyor systems, hereinafter referred to as "BR 104 EU". The closure system can be designed for installation at floor level or for installation at raised position.

"BR 104 EU" primarily consists of the following components¹:

- Single-leaf flap leaf

The approx. 48 mm thick flap leaf consists of an inner framework of steel hollow profiles (30 mm x 20 mm x 2 mm), filled with a 30 mm thick calcium silicate board and both-sided covered with a 9 mm thick calcium silicate board. The sliding leaf may be covered with ≤ 1 mm thick steel plate or wood veneer. The calcium silicate boards are secured with water glass adhesive and steel cramps.

The flap leaf is fixed to the wall by a L steel section (60 mm x 60 mm x 6 mm) and steel hinges. Wall covering of the flap leaf at the side and at the top amounts to 100 mm.

- Fixed panel with clearance for the conveyor

The 170 mm thick fixed panel consists of several calcium silicate boards or gypsum boards which are secured with water glass adhesive. The fixed panel is secured to the wall via brackets. The clearance in the fixed panel is configured for the respective conveyor technology. Various intumescent materials are used in the necessary functional gaps.

- Wall frame and locking device of the flap leaf

The closed flap leaf is enclosed by a wall frame of L steel sections (60 mm x 40 mm x 5 mm). The flap leaf will be locked by two locking devices on the wall frame.

- Seal system

In the overlap of the flap leaf and adjacent wall on the side of the flap leaf facing the wall strips of an intumescent material are positioned (see annex 3).

On the lower edge of the flap leaf a sealing segment with strips of an intumescent material is positioned above the conveyor system. Strips of an intumescent material are positioned in the conveyor technology area in the fixed panel (see annex 4).

The sealing segments on the flap leaf consist of several strips of calcium silicate board. The fixed panel in the conveyor technology area consist of several strips of calcium silicate board or gypsum board. Strips of an intumescent material must be positioned in the residual gaps.

- Closing device (closing weight system)

"BR 104 EU" shall be closed via stored mechanical energy (deadweight of the flap leaf).

¹ The documents describing the structure of "BR 104 EU" in detail and the product specifications of the building materials used are deposited with DIBt.

2 Specification of the intended use in accordance with the applicable European Assessment Document

In accordance with this European Technical Approval, the "BR 104 EU" was assessed as closure to seal necessary openings of trackbound conveyors (see table 2) in internal walls (see table 1).

When the intumescent materials¹ are used, the verified ambient conditions (e.g. the category stated in TR024²) are to be observed.

The "BR 104 EU" is not intended for passenger transportation. The normal position of the closure shall be opened or closed.

The "BR 104 EU" shall only be used if the following conditions apply:

- The normally-open closure (open in the normal position; closes in the event of a fire) shall be equipped with a hold-open system suitable for the closure – where applicable in conjunction with the national regulations.
- The normally-open closure, which cannot be opened from a fixed position (floor, pedestal etc.), is to be equipped with a drive to open the closure.
- It is to be ensured that the closing of the closure is not obstructed by conveyed goods or other objects.
- It is to be ensured that the closed closure cannot be damaged by conveyed goods or other objects.

The verifications and assessment methods on which this European Technical Assessment is based lead to the assumption of a working life of the "BR 104 EU" of at least 10 years. The indications given on the working life cannot be interpreted as a guarantee given by the producer, but are to be regarded only as a means for choosing the right products in relation to the expected economically reasonable working life of the works.

NOTE: Other requirements and other EU Directives may be applicable to the product(s) falling within the scope of this document.

² TR024 Characterization, Aspects of Durability and Factory Production Control for Reactive Materials, Components and Products

Table 1: Permitted dimensions of the clearance of the opening in internal walls

Component (supporting construction) in which the closure can be installed ^{a)}	Maximum fire resistance class ^{b)}	Clearance of the component opening		
		clear width	clear height	clear surface
High-density solid wall Masonry or solid concrete with an overall density of $\geq 800 \text{ kg/m}^3$ and a thickness $\geq 200 \text{ mm}$	E 90 EI ₂ 90 EW 60	min. 500 max. 1.500	min. 500 max. 1.500	min. 0,25 max. 2,25
Low-density solid wall Aerated concrete with an overall density of $\geq 450 \text{ kg/m}^3$ and a thickness $\geq 200 \text{ mm}$	E 90 EI ₂ 90 EW 60	min. 500 max. 1.500	min. 500 max. 1.500	min. 0,25 max. 2,25
a) Supporting construction to EN 1366-7 ³ , section 7.2 or EN 1363-1 ⁴ , section 7.2				
b) Fire resistance class per EN 13501-2 ⁵ in accordance with the Evaluation Report				

Table 2: Permitted sealing systems for the continuous conveyor technology⁶

Sealing system for	Fixed panel thickness (gypsum boards)	Minimum penetration seal depth of the seal on the fixed panel (Penetration seal via calcium silicate boards)	Minimum penetration seal depth at the flap leaf	Maximum fire resistance class
Roll conveyor	170 mm	170 mm between the rollers: 2 x 20 mm webs	124 mm	EI 90
Belt conveyor	170 mm	170 mm	124 mm	EI 90
Chain conveyor	170 mm	170 mm	124 mm	EI 90

The conveyor tracks shall be positioned at the bottom and can be continuous in the closing area of the flap leaf.

3 Performance of the product and references to the methods used for its assessment

3.1 Safety in case of fire (BWR 2)

Essential characteristic	Performance
Fire resistance (EN 13501-2)	see clause 2, table 1 and 2
Mechanical durability of self-closing (EN 13501-2)	C5
Reaction to fire (EN 13501-1)	see following table 3

- ³ EN 1366-7:2004 Fire resistance tests for service installations - Part 7: Conveyor systems and their closures
- ⁴ EN 1363-1:2012 Fire resistance tests - Part 1: General requirements
- ⁵ EN 13501-2:2016 Fire classification of construction products and building elements - Part 2: Classification using data from fire resistance tests, excluding ventilation services
- ⁶ see Annex 4

Table 3: Reaction to fire of the used materials

component	material	class according to EN 13501-1
flap leaf, fixed panel	calcium silicate boards	A1
	gypsum boards	A1
	water glass adhesive	at least class E
hinges, guide	steel	A1
seal system	Intumescent material – Promaseal PL	at least class E
closing device	steel	A1
fixing material	steel	A1

3.2 Hygiene, health and the environment (BWR 3)

No performance assessed.

4 Assessment and verification of constancy of performance (AVCP) system applied, with reference to its legal base

In accordance with EAD No. 350022-01-1107, the applicable European legal act is: 1999/454/EG.

The system to be applied is: 1

In addition, with regard to e.g. reaction to fire of components and materials for products covered by this EAD the applicable European legal act is: 1999/454/EG.

The systems to be applied are: 1 / 3 / 4 (dependent on classes of reaction to fire)

5 Technical details necessary for the implementation of the AVCP system, as provided for in the applicable EAD

Technical details necessary for the implementation of the AVCP system are laid down in the control plan deposited with Deutsches Institut für Bautechnik.

The manufacturer shall provide installation instructions and maintenance instructions for every "BR 104 EU". The maintenance instructions shall clearly indicate which work is to be performed to ensure that the installed closure system continues to perform its task after long-term use.

The manufacturer shall provide instructions on processing, packaging, transport, storage and use, maintenance and repair of the construction product.

Issued in Berlin on 22 June 2022 by Deutsches Institut für Bautechnik.

Sylvia Panneck
Head of Section

beglaubigt:
Biedermann

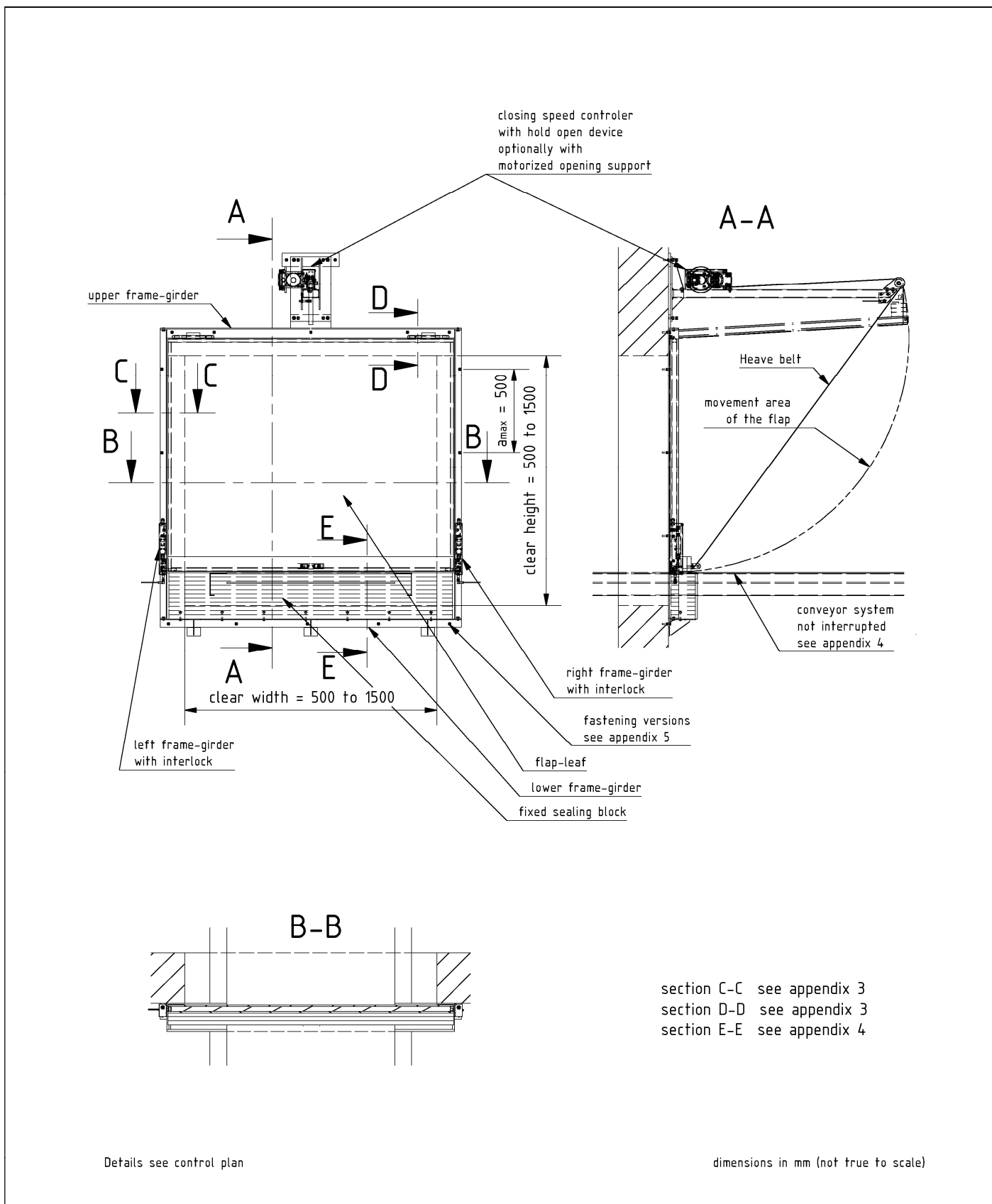

Electronic copy of the ETA by DIBt: ETA-18/0297

BR 104 EU

Overview
Installation in walls
Flap for conveyor technique without side wall

Annex 1

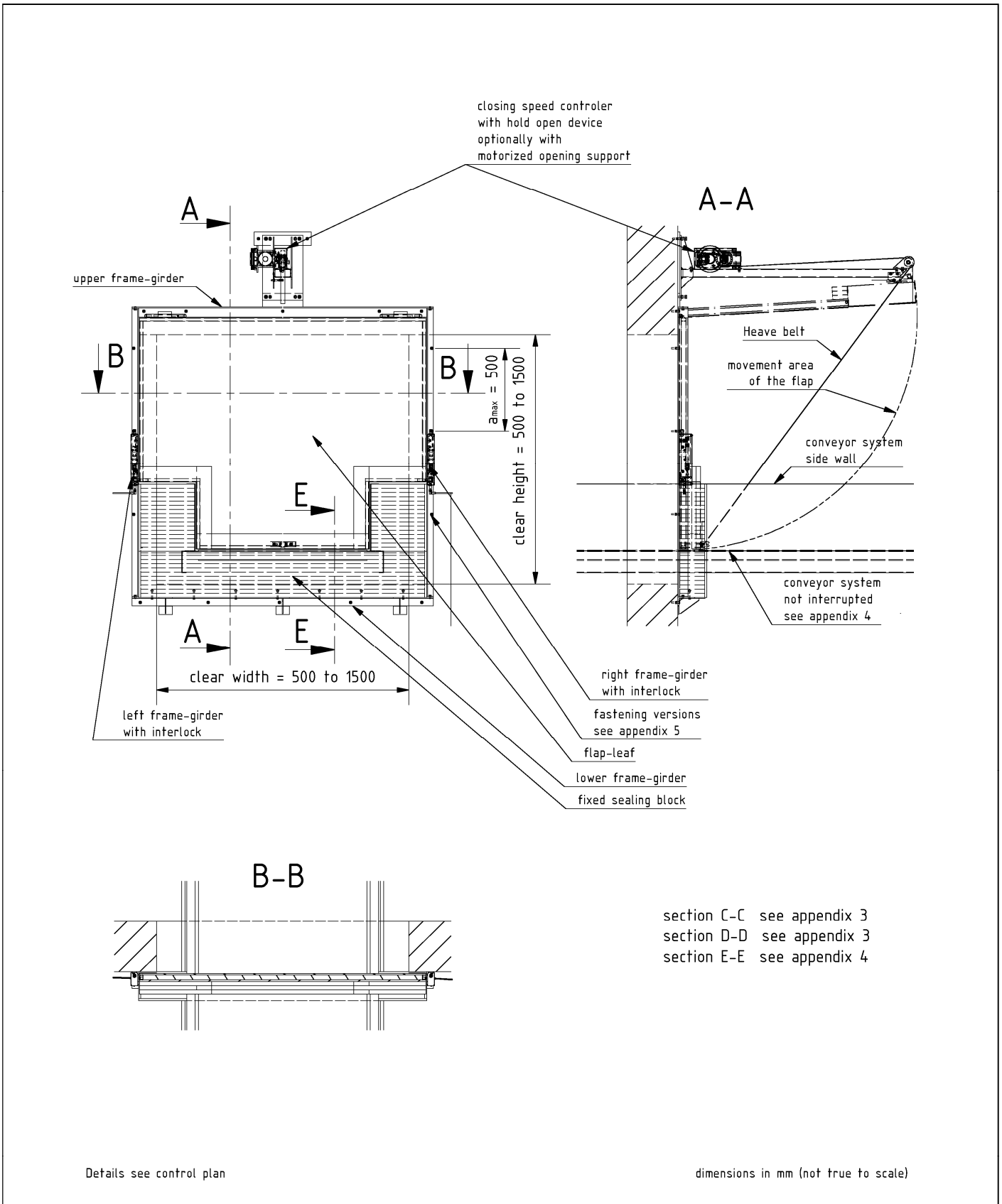

Electronic copy of the ETA by DIBt: ETA-18/0297

BR 104 EU

Overview
Installation in walls
Flap for conveyor technique with side wall

Annex 2

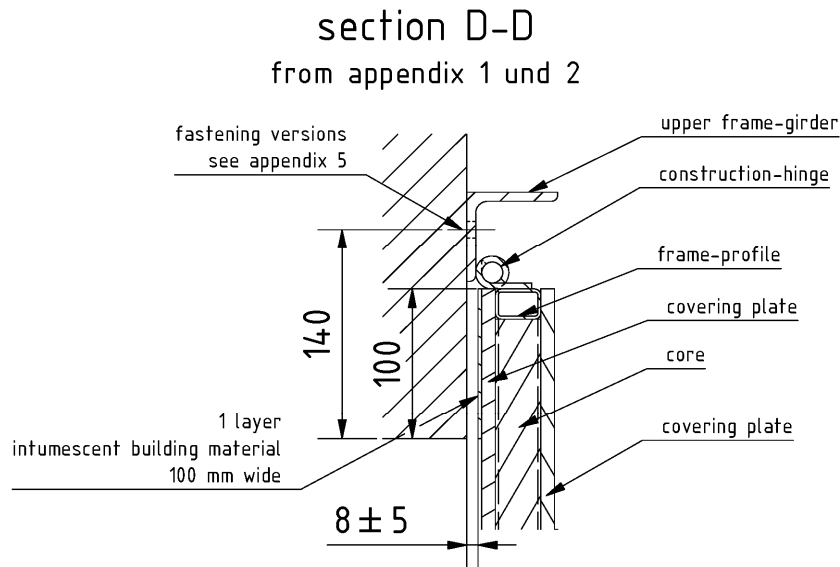
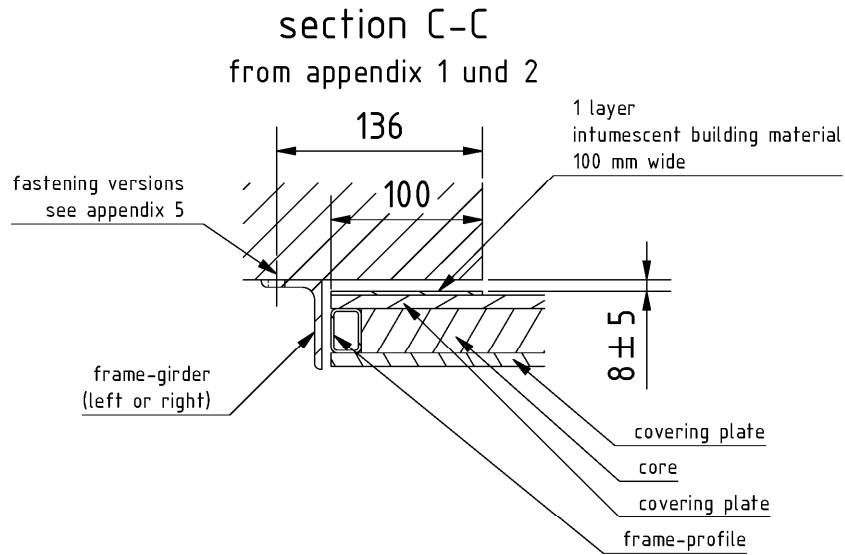

basic flap-leaf structure:

- core: calcium silicate board (30 mm)
- covering plate: calcium silicate board (9 mm)
- thickness of the flap-leaf = 48 mm

Details see control plan

dimensions in mm (not true to scale)

BR 104 EU

Details concerning wall sealing
- lateral (section C - C)
- at the top (section D - D)

Annex 3

schematic diagram
sealing of belt conveyor

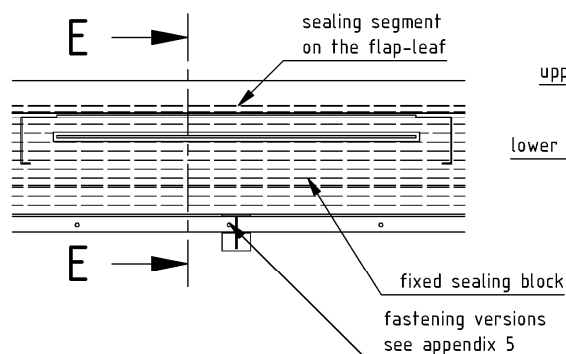

section E-E

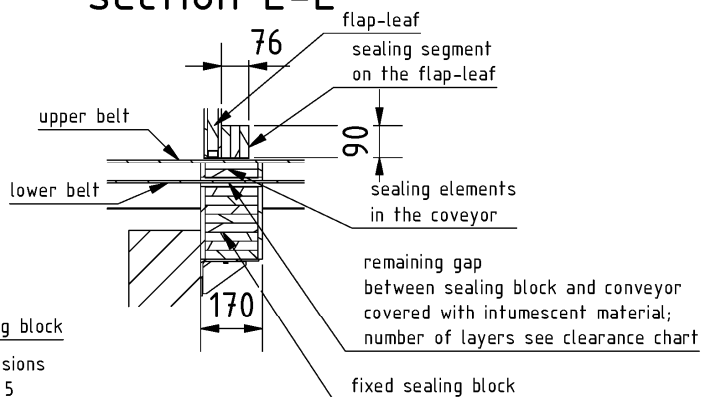

schematic diagram
sealing of roller conveyor

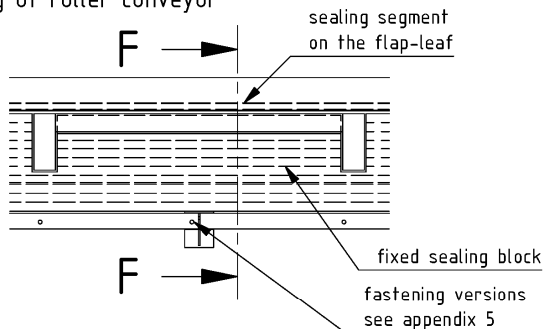

section F-F

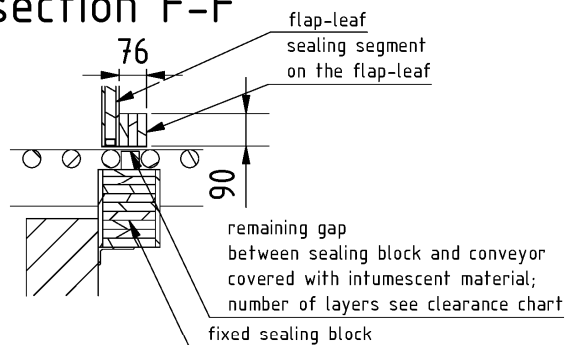

schematic diagram
sealing of chain conveyor

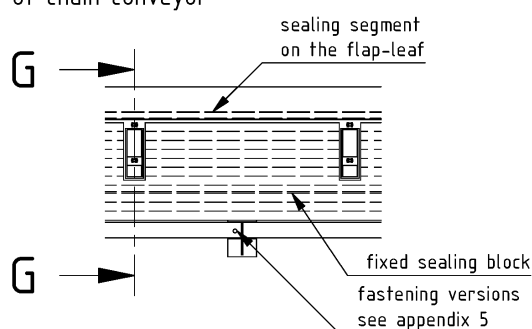

section G-G

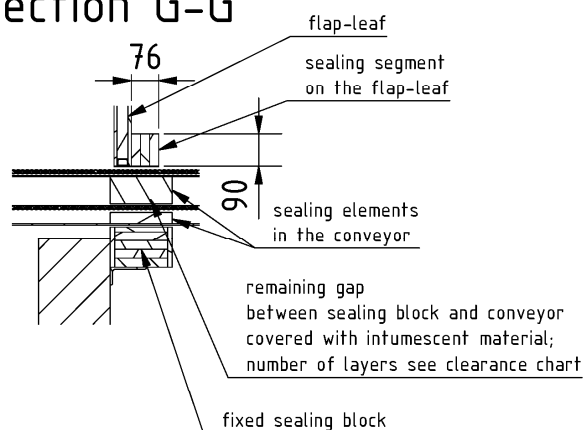

Details see control plan

clearance for remaining gaps between the continuous parts of the conveyor and the closure (application of intumescent material PROMASEAL-PL; thickness per layer: 2,5 mm)	
remaining gap (mm)	minimum number of layers
10 to 15	1 layer
16 to 30	2 layers
31 to 45	3 layers

Attention: the remaining gaps should be implemented as small as possible

dimensions in mm (not true to scale)

manner of fastening 1

concrete wall, min. 175 mm thick
masonry (solid walls with high density), min. 175 mm thick
full-length threaded rod

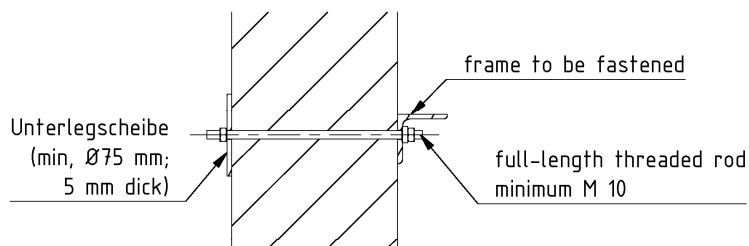

manner of fastening 2

masonry (solid walls with low density), min. 175 mm thick
full-length threaded rod

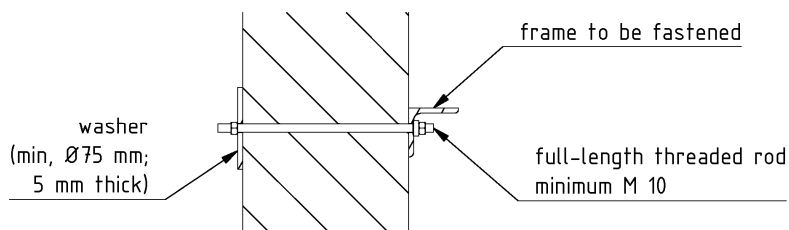

manner of fastening 3

concrete wall, min. 175 mm thick
metal dowel with ETA
considering TR020

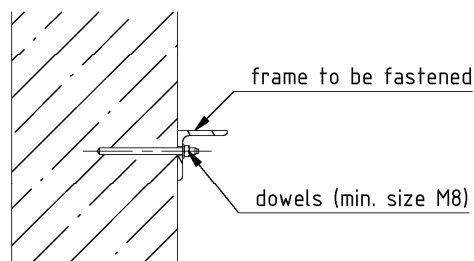

Details see control plan

dimensions in mm (not true to scale)

BR 104 EU

Kind of fastening

Annex 5