

Approval body for construction products
and types of construction

Bautechnisches Prüfamt

An institution established by the Federal and
Laender Governments



European Technical Assessment

ETA-21/1022 of 6 January 2022

English translation prepared by DIBt - Original version in German language

General Part

Technical Assessment Body issuing the
European Technical Assessment:

Deutsches Institut für Bautechnik

Trade name of the construction product

Atlas Concorde KEIL undercut anchor KH

Product family
to which the construction product belongs

Fastener for the rear fixing of facade panels made of
ceramic plates (stoneware) in accordance with
EN 14411:2012

Manufacturer

Ceramiche Atlas Concorde s.p.A.
Via Canaletto 141
41042 SPEZZANO DI FIORANO (MO)
ITALIEN

Manufacturing plant

Plant 1 to 3

This European Technical Assessment
contains

18 pages including 4 annexes which form an integral part
of this assessment

This European Technical Assessment is
issued in accordance with Regulation (EU)
No 305/2011, on the basis of

EAD 330030-00-0601, Edition 10/2018

The European Technical Assessment is issued by the Technical Assessment Body in its official language. Translations of this European Technical Assessment in other languages shall fully correspond to the original issued document and shall be identified as such.

Communication of this European Technical Assessment, including transmission by electronic means, shall be in full. However, partial reproduction may only be made with the written consent of the issuing Technical Assessment Body. Any partial reproduction shall be identified as such.

This European Technical Assessment may be withdrawn by the issuing Technical Assessment Body, in particular pursuant to information by the Commission in accordance with Article 25(3) of Regulation (EU) No 305/2011.

Specific Part

1 Technical description of the product

The Atlas Concorde KEIL undercut anchor KH is a fastener consisting of a crosswise slotted anchor sleeve with an M6 internal thread, at the upper edge of which a hexagon is formed to it and a respective hexagon screw with a tooth lock washer formed to it. The anchor sleeve and the hexagon screw with a tooth lock washer formed to it are made of stainless steel. Instead of the hexagon screw a grub screw or threaded rod made of stainless steel may also be used. The anchor is put into an undercut drill hole and by driving-in the screw it is placed form-fitted and deformation-controlled.

The product description is given in Annex A. The material values, dimensions and tolerances of the components of the fastener not indicated in the annexes shall correspond to the values laid down in the technical documentation.

2 Specification of the intended use in accordance with the applicable European Assessment Document

The performances given in Section 3 are only valid if the fastener is used in compliance with the specifications and conditions given in Annex B.

The verifications and assessment methods on which this European Technical Assessment is based lead to the assumption of a working life of the fasteners of at least 50 years. The indications given on the working life cannot be interpreted as a guarantee given by the producer, but are to be regarded only as a means for choosing the right products in relation to the expected economically reasonable working life of the works.

3 Performance of the product and references to the methods used for its assessment

3.1 Mechanical resistance and stability (BWR 1)

Essential characteristic	Performance
Characteristic resistance to breakout or pull-out failure under tension load	See Annex C 1
Characteristic resistance to breakout or pull-out failure under shear load	See Annex C 1
Characteristic resistance to breakout or pull-out failure under combined tension and shear load	See Annex C 1
Edge distance and spacing	See Annex C 1
Durability	Corrosion Resistance Class (CRC) III in accordance with EN 1993-1-4:2015
Characteristic resistance to steel failure under tension and shear loads	See Annex C 1

3.2 Safety in case of fire (BWR 2)

Essential characteristic	Performance
Reaction to fire	Class A1

English translation prepared by DIBt

4 Assessment and verification of constancy of performance (AVCP) system applied, with reference to its legal base

In accordance with EAD No. 330030-00-0601 the applicable European legal act is: [97/161/EG].
The system to be applied is: 2+

5 Technical details necessary for the implementation of the AVCP system, as provided for in the applicable European Assessment Document

Technical details necessary for the implementation of the AVCP system are laid down in the control plan deposited with Deutsches Institut für Bautechnik.

Issued in Berlin on 6 January 2022 by Deutsches Institut für Bautechnik

Dipl.-Ing. Beatrix Wittstock
Head of Section

beglaubigt:
Aksünger

<p>Installed fastener</p>	
<p>Fixing example</p>	
<p>Atlas Concorde KEIL undercut anchor KH</p>	
<p>Product description Installed fastener and example for fixing element</p>	<p>Annex A 1</p>

Anchor sleeve (dimension in mm)

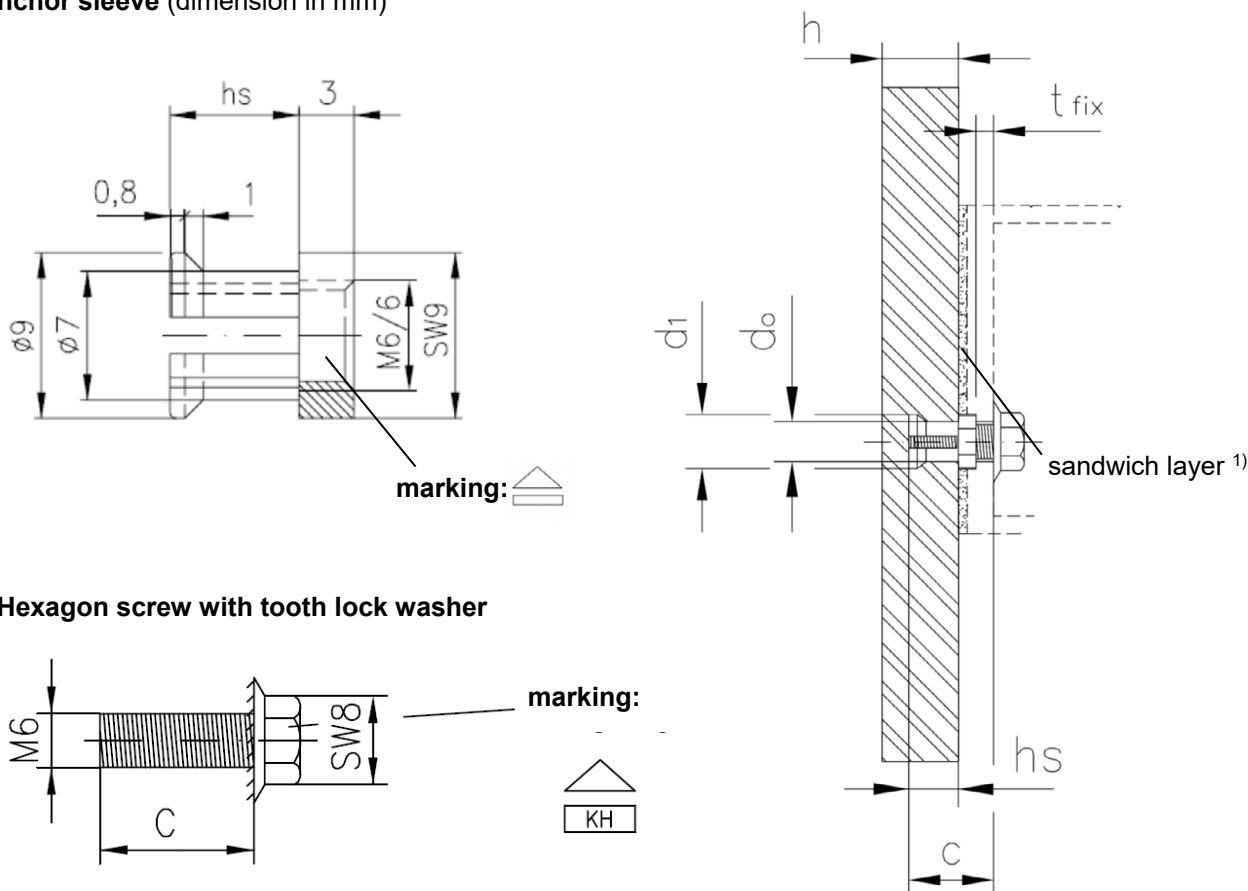

¹⁾ elastic sandwich layer (e.g. EPDM) - thickness 1.0 to 3.0 mm

Table A1: Dimensions and Materials

Anchor type		KH 5,5	KH 7,0	KH 8,5
anchorage depth	$h_s =$ [mm]	5,5	7,0	8,5
panel thickness	$h \geq$ [mm]	8,0	9,5	11,0
diameter of drill hole	$d_o =$ [mm]	7,0		
Diameter of undercut	$d_1 =$ [mm]	9,0		
screw length	$c =$ [mm]	$h_s + 3\text{mm} + t_{\text{fix}}$		
installation torque moment	T_{inst} [Nm]	$2,5 \leq T_{\text{inst}} \leq 4,0$		
Materials		KH 5,5	KH 7,0	KH 8,5
anchor sleeve		Stainless steel 1.4404 according to EN 10 088:2014		
hexagon screw with tooth lock washer		Stainless steel 1.4401, 1.4404 or 1.4578 according to EN 10 088:2014		

Atlas Concorde KEIL undercut anchor KH

Product description
Dimensions and materials

Annex A 2

Specifications of intended use

Anchorage subject to:

- Static and quasi-static loads.

Base materials:

- The stoneware façade panels shall correspond to the group Al_a, Al_b, Bl_a or Bl_b according to EN 14411:2012
- Characteristic values of the panel correspond Table B 1
- The façade panels and the constancy of the performance of the fastener shall be checked in follow

Classification test (Initial type test)

The following values shall be checked on at least 10 samples:

- bending strength - determined according to EN ISO 10545-4:2014-11 with the "visible face" on top; deviating from EN ISO 10 545-4:2014-11 the dimension of the test specimen is l/b = 400/200 mm and the support span is l_s = 300 mm
- axial tension load – determined on test specimens with dimensions of l/b = 200/200 mm, an edge distance of 100 mm and a support diameter of Ø = 70 mm (panel thickness and embedment depth according to the construction project); N_{U5%} ≥ N_{Rk}: Characteristic resistance to tension load according to Table C1
- shear load – determined on test specimens with dimensions of l/b = 400/200 mm and an edge distance of 100 mm (panel thickness and embedment depth according to the construction project);
V_{U5%} ≥ V_{Rk}: Characteristic resistance to shear load according to Table C1

Acceptance Test (Verification of constancy of performance)

For each construction project the following values shall be checked on at least 10 samples independent of the scope of delivery:

- axial tension load – determined on test specimens with dimensions of l/b = 200/200 mm, an edge distance of 100 mm and a support diameter of Ø = 70 mm (panel thickness and embedment depth according to the construction project); N_{U5%} ≥ N_{Rk}: Characteristic resistance to tension load according to Table C1

From the test results (Classification and Acceptance tests) the 5 %-Fractile (confidence level of 75 %, unknown standard deviation and lognormal distribution) shall be determined.

With the determined values of the 5 %-Fractile the façade panels are to be classified according to the respective property class corresponding to Table B1.

Table B1: Characteristic value of the panel

Strength class of facade panels		A	B	C
Bending strength ("visible face" on top)	$\sigma_{u5\%} \geq$ [N/mm ²]	35	40	45
Modulus of elasticity	E = [N/mm ²]	30000		
poisson's ratio	$\nu =$ [-]	0,2		
specific weight	$\gamma =$ [kN/m ³]	25,0		
Panel thickness	h ≥ [mm]	8		

Atlas Concorde KEIL undercut anchor KH

Intended use
Specifications

Annex B 1

Test specimen for tension test and shear test

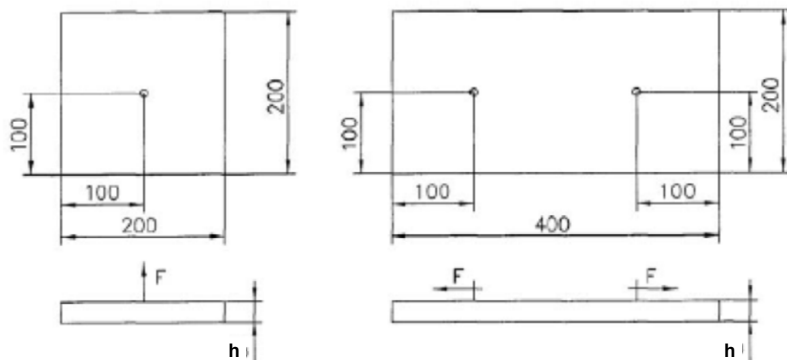

Use conditions (Environmental conditions):

- According to EN 1993-1-4:2015 according to the Corrosion Resistance Class of the fastener III

Design:

Generals:

- Each façade panel is fixed with at least four anchors in a rectangular arrangement via single agraffes on the substructure (for small panels or small fitted pieces, differential or fill-in pieces the number and position of the anchors shall be chosen constructively).
- Edge distance and spacing shall be observed. For small fitted pieces, differential and fill-in pieces the edge distance and spacing shall be chosen.
- The substructure is constructed such that the façade panels are fixed according to Annex B 7 technically strain-free via skids (loose bearings) and one fixed point (fixed bearing) - the fixed point may be placed at the panel edge or in the panel field - and that there are no additional loads acting on the panels and their fixings due to excentric load application / load transfer (symmetrical bearing of the panels).
- Constraint loads shall be into account for design, If constraint loads exists.
- Two fixing points of the façade panel are designed such that they are able to carry the dead load of the façade panel.
- When using agraffes on horizontal load-bearing profiles the fixing points of a façade panel situated horizontally at the same height are fastened in each case to the same load-bearing profile.
- Verifiable calculation notes and drawings shall be prepared taking account of the loads to be anchored, the nature and strength of the base materials and the dimensions of the anchorage members as well as of the relevant tolerances. The position of the anchor is indicated on the design drawings.
- The calculation shall be carried out in a linear elastic manner. The stiffness of the substructure shall be considered for the respective case of application.
- For hanging panels (overhead installation) or reveals respectively the load direction shall be taken into consideration and the combinations of actions shall be based on EN 1990:2002+A1:2005+A1:2005/AC:2010.

Atlas Concorde KEIL undercut anchor KH

Intended use
Specifications

Annex B 2

Installation:

- The drillings are done at the factory or on site under workshop conditions; when making the drillings on site the execution is supervised by the responsible project supervisor or a skilled representative of the project supervisor.
- Making of the undercut drilling is done with the drill bit according to Annex B 6 and a special drilling device in accordance with the information deposited with Deutsches Institut für Bautechnik.
- In case of aborted hole: new drilling at a minimum distance away of twice the depth of the aborted hole.
- the geometry of the drill hole is checked on 1 % of all drillings. The following dimensions shall be checked and documented according to manufacturer's information and testing instructions by means of a KEIL depth control guide according to Annex B 6:
 - Volume of the undercut drill hole.
 - Depth position of the undercut; the distance between the lower edge of the KEIL depth control guide and the façade panel is between 0,0 and 0,3 mm (see Annex B 5).

If the tolerances given in Annex A 2 are exceeded, the geometry of the drill hole shall be checked on 25 % of the drillings performed. No further drill hole may exceed the tolerances otherwise all the drill holes shall be controlled. Drilling holes falling below or exceeding the tolerances shall be rejected.

Note: Checking the geometry of the drill hole on 1 % of all drillings means that on one of the 25 panels (this corresponds to 100 drillings in façade panels with four anchors) one drilling shall be checked. If the tolerances given in Annex A 3 are exceeded the extent of the control shall be increase to 25 % of the drillings, i.e. one drilling each shall be checked on all the 25 panels.

- During transport and storage on site the façade panels are protected from damages; the façade panels are not be hung up jerkily (if need be lifters shall be used for hanging up the façade panels); façade panels and reveal panels respectively with incipient cracks are not be installed.
- The façade are installed by skilled specialists and the laying instructions of the manufacturer shall be paid attention to.
- Between agraffe and façade panel an elastic sandwich layer may be placed. (see Annex A 1).
- The façade panels are aranged in a "reclined" or "uprighth" position.
- Overhead installation is allowed.

Electronic copy of the ETA by DIBt: ETA-21/1022

Atlas Concorde KEIL undercut anchor KH	Annex B 3
Intended use Specifications	

drill hole geometry

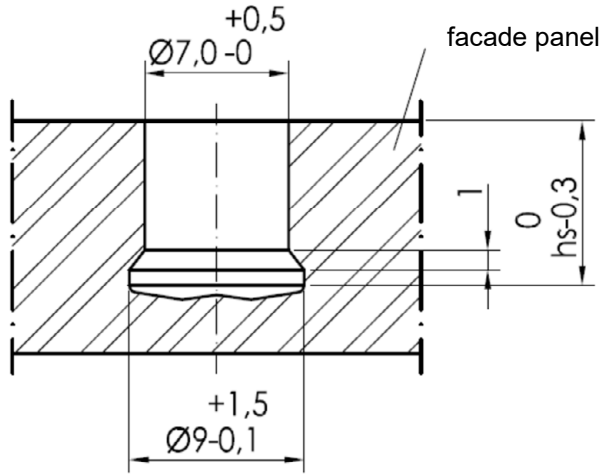

drill geometry

for KEIL - Façade drill DIA 12/0,8

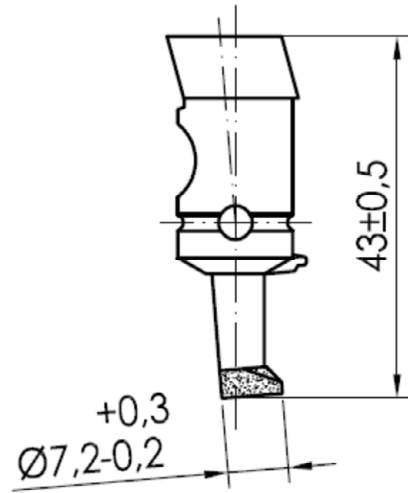

KEIL depth control guide

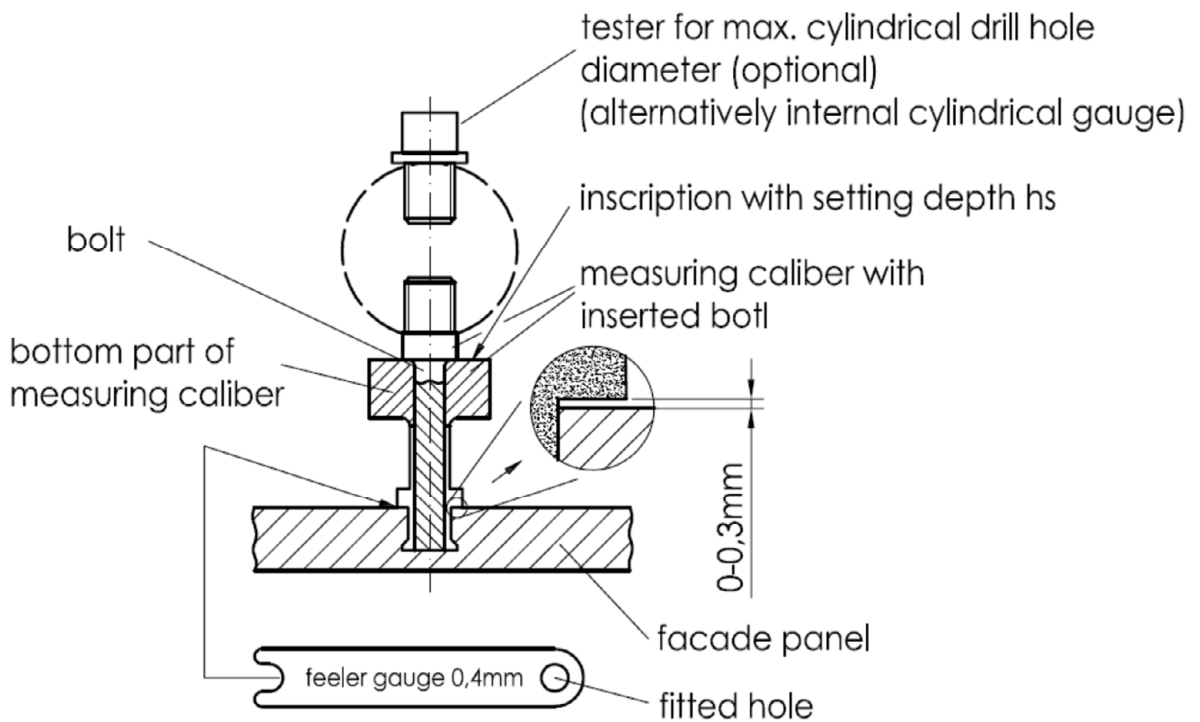

Electronic copy of the ETA by DIBt: ETA-21/1022

Atlas Concorde KEIL undercut anchor KH

Intended use
Drill hole dimensions
Setting tools and testing equipment

Annex B 4

Definition of edge distance and spacing

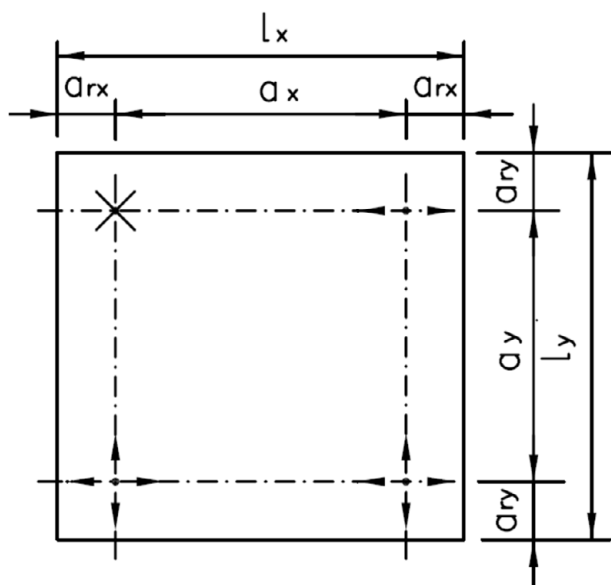

Legend:

- $a_{r,x,y}$ = edge distance – distance of an anchor to the panel edge
- $a_{x,y}$ = spacing – distance between anchors
- L_x = greater length of the façade panel
- L_y = smaller length of the façade panel
- X = fixed point (fixed bearing)
- ⊕ = horizontal skid (loose bearing)
- ⊕⊕ = horizontal and vertical skid (loose bearing)

Example for fixed point and loose bearing

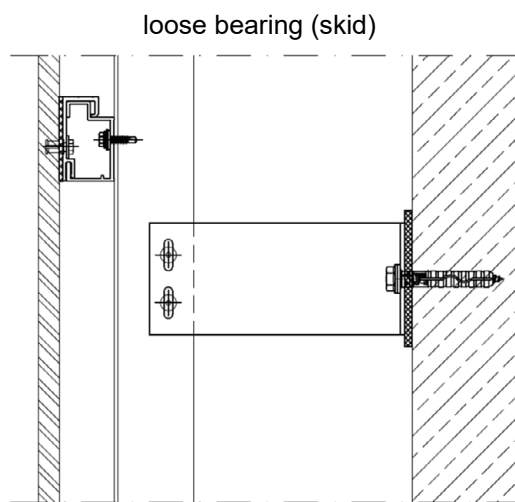
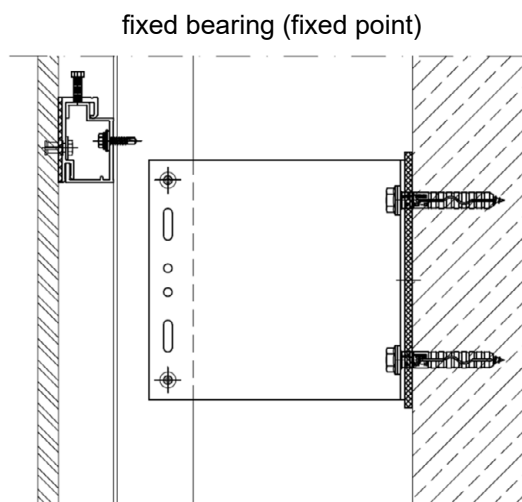

Atlas Concorde KEIL undercut anchor KH

Intended use

Definition of edge distance and spacing,
Example for fixed point and loose bearing

Annex B 5

Installation instructions

1. Drilling the undercut hole

a) Cylindrical drilling

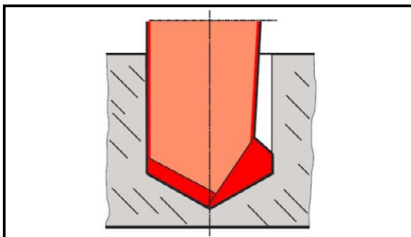

b) Undercutting

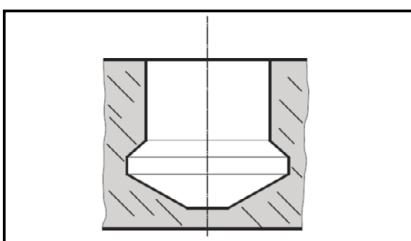
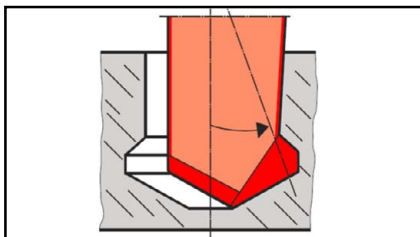

c) Finished undercut hole

2. Checking the undercut hole

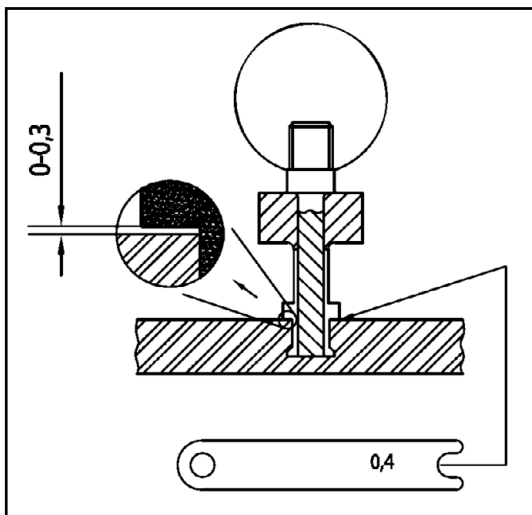

With KEIL depth control guide

Atlas Concorde KEIL undercut anchor KH

Intended use
Installation instructions

Annex B 6

3.1 Installation of anchor (sleeve and screw)

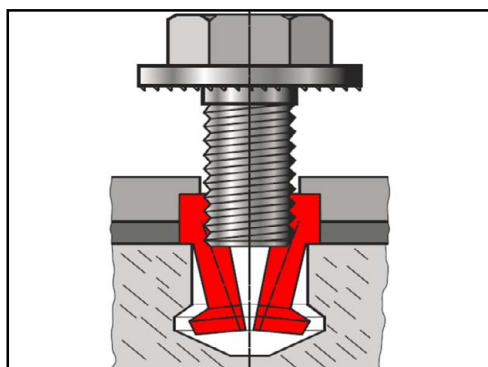

a) Insert the sleeve in the undercut hole and drill the screw in the sleeve

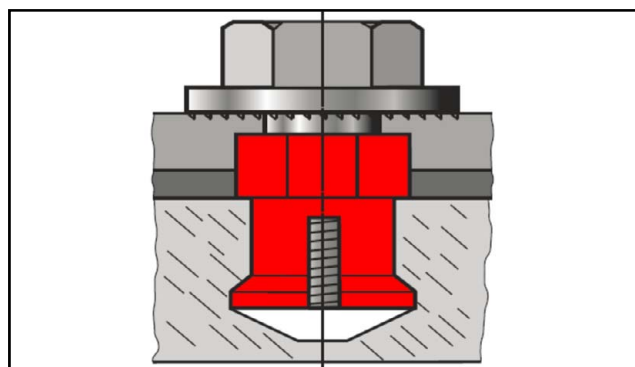

b) Installed anchor

3.2 Installation of anchor (sleeve and grub screw)

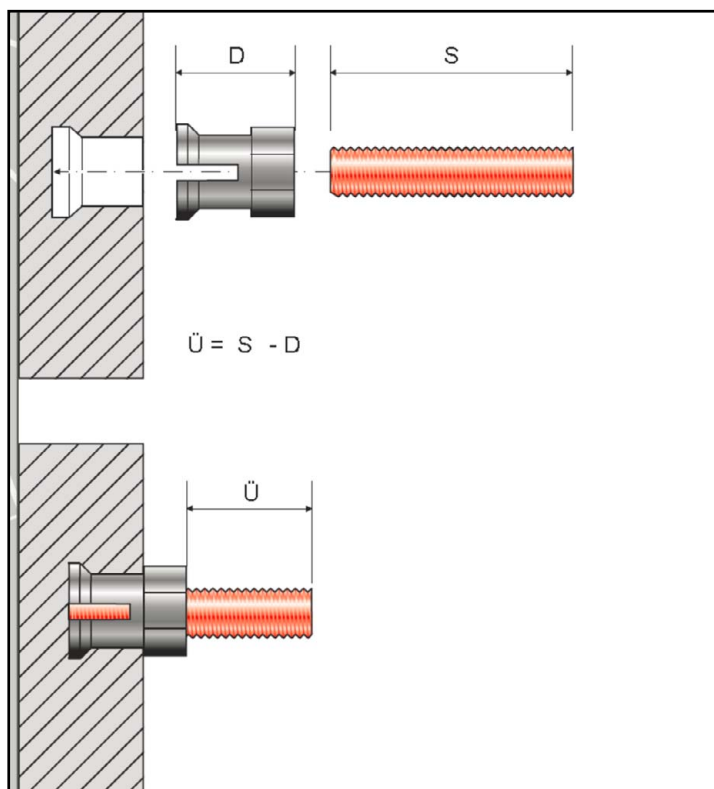

a) Insert the sleeve in the undercut hole

b) Drill the grub screw in the sleeve

c) Installed anchor

Atlas Concorde KEIL undercut anchor KH

Intended use
Installation instructions

Annex B 7

Table C1: Characteristic values for the design of the anchor

Embedment depth	$h_s =$	[mm]	5,5	7,0	8,5	
Panel thickness	$h \geq$	[mm]	8,0	9,5	11,0	
Characteristic resistance to tension load	Class A	$N_{Rk} =$	[kN]	1,0	1,5	2,7
	Class B			1,1	1,6	2,8
	Class C			1,2	1,7	3,0
characteristic resistance to shear load	Class A	$V_{Rk} =$	[kN]	2,0	2,2	2,4
	Class B			2,1	2,3	2,5
	Class C			2,2	2,4	2,6
edge distance ¹⁾	$a_r \geq$	[mm]	100			
spacing	$a \geq$	[mm]	200			
charakt. resistance steel failure	tension load	$N_{Rk,s} =$	[kN]	14,1		
	shear load	$V_{Rk,s} =$	[kN]	7,0		
Value for tri-linear function with combined tension and shear load	$\chi =$	[-]	1,0			

¹⁾ The edge distance may be reduced to 50 mm. For edge distances $50 \text{ mm} \leq a_r \leq 100 \text{ mm}$ the characteristic values of resistance for shear loads shall be reduced by the factor $a_r/100$ [a_r in mm]; in case of different edge distances the smaller value is decisive

Atlas Concorde KEIL undercut anchor KH

Performance
Characteristic values for the design of the anchor

Annex C 1

Verification ultimate limit state:

Anchorage are designed under the responsibility of an engineer experienced in anchorages and facade construction.

Verification to breakout or pull-out failure

$$\frac{N_{Ed}}{N_{Rd}} \leq 1$$

$$\frac{V_{Ed}}{V_{Rd}} \leq 1$$

$$\frac{N_{Ed}}{N_{Rd}} + \frac{V_{Ed}}{V_{Rd}} \leq X$$

N_{Ed} : Design value of the tensile force

$$N_{Ed} = N_{Ek,w} \cdot \gamma_F + N_{Ek,v} \cdot \gamma_F$$

$N_{Ek,w}$: characteristic value of the tensile force of wind load

γ_F : partial safety factor according to EN 1990:2002+A1:2005+A1:2005/AC:2010

$N_{Ek,v}$: For flush fixed anchors and for installation of horizontal load-bearing profiles permanent loads due to torsion of the profile shall be considered in addition to actions from dead load and wind in direction of the anchor axes. The verification can be omitted, if there is no horizontal distance between anchor and vertical load-bearing profile ($N_{Ek,v} = 0$).

$$N_{Ek,v} = V_{Ek} \cdot e/z$$

V_{Ek} = characteristic value of the shear force due to dead load of the façade panel

e and z [mm] see picture

M shear centre

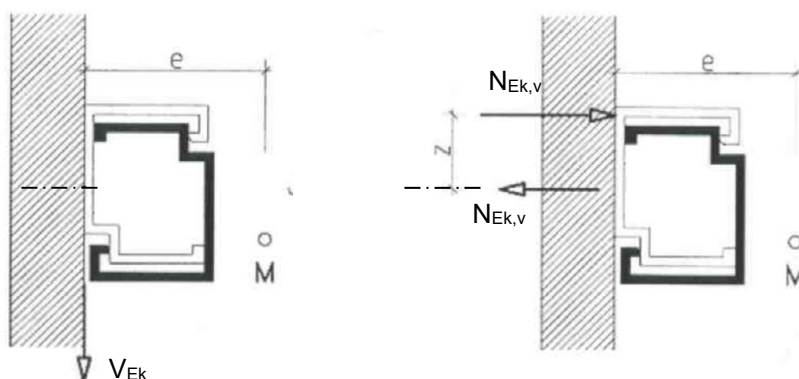

N_{Rd} : design value of the tensile load-bearing capacity

$$N_{Rd} = N_{Rk} / \gamma_M$$

N_{Rk} : characteristic value of the tensile load-bearing capacity according to Table C1
 $\gamma_M = 1,8$; recommended partial safety factor, in absence of national regulations

V_{Ed} : design value of the shear force

$$V_{Ed} = V_{Ek} \cdot \gamma_F$$

V_{Ek} : characteristic value of the shear force

γ_F : partial safety factor according to EN 1990:2002+A1:2005+A1:2005/AC:2010

V_{Rd} : design value of the shear load-bearing capacity

$$V_{Rd} = V_{Rk} / \gamma_M$$

V_{Rk} : characteristic value of the shear load-bearing capacity according to Table C1
 $\gamma_M = 1,8$; recommended partial safety factor, in absence of national regulations.

X: see Annex C 1

Atlas Concorde KEIL undercut anchor KH

Informative

Characteristic resistance to breakout or pull-out failure

Annex D 1

Verification to steel failure

$$\frac{N_{Ed}}{N_{Rd,s}} \leq 1,0$$

$$\frac{V_{Ed}}{V_{Rd,s}} \leq 1$$

$$\left(\frac{N_{Ed}}{N_{Rd,s}}\right)^2 + \left(\frac{V_{Ed}}{V_{Rd,s}}\right)^2 \leq 1,0$$

N_{Ed} : Design value of the tensile force, see Annex D 1

$N_{Rd,s}$: design value of steel failure under tension load

$$N_{Rd,s} = N_{Rk,s} / \gamma_{Ms}$$

$N_{Rk,s}$: Characteristic resistance to steel failure under tension according to Table C1

$\gamma_{Ms} = 1,87$ recommended partial safety factor, in absence of national regulations.

V_{Ed} : design value of the shear force, see Annex D 1

$V_{Rd,s}$: design value of steel failure under shear load

$$V_{Rd,s} = V_{Rk,s} / \gamma_{M}$$

$V_{Rk,s}$: Characteristic resistance to steel failure shear load according to Table C1

$\gamma_{M,s} = 1,56$ recommended partial safety factor, in absence of national regulations.

Atlas Concorde KEIL undercut anchor KH	
Informative Characteristic resistance to steel failure	Anhang D 2

Verification to wind loads for selective panel sizes and bearing conditions

For the panel sizes and bearing conditions given in Table D1 depending on the strength class, panel thickness, setting depth and edge distance the verification of structural stability is deemed to be verified, if the following condition is met:

$$W_{Ed} \leq W_{Rk} / \gamma_M$$

With:

W_{Ed} = design value of the existing wind load

W_{Rk} = characteristic resistance to wind loads according to Table D1

γ_M = partial safety factor according to Table D1

Table D1: characteristic resistance W_{Rk} to wind loads for selective panel sizes and bearing conditions depending on property class, panel thickness, setting depth and edge distance

Class	h	h _s	a _{rx}	a _{ry}	panel sizes	bearing condition ¹⁾	W _{Rk}	γ _M
[-]	[mm]	[mm]	[mm]	[mm]	[mm]	[-]	[kN/m ²]	[-]
B	≥ 11,5	≥ 7	60-120	100-200	600 × 1200	4 Agraffen	5,4	1,8
B	≥ 11,5	≥ 7	60-120	75-150	600 × 900	4 Agraffen	8,1	
B	≥ 9,5	≥ 7	60-120	60-120	600 × 600	4 Agraffen	10,8	
A	≥ 13	≥ 8,5	123	240-350	900 × 1200	4 Agraffen	2,2	
A	≥ 13	≥ 8,5	123	240-350	900 × 1200	6 Agraffen	2,7	
A	≥ 13	≥ 8,5	123	240-350	900 × 1200	8 Agraffen	4,3	
C	≥ 13	≥ 7	100	100	900 × 900	4 Agraffen	4,3	

¹⁾ maximum size of agraffe: width = 30 mm, height = 60 mm

Object-related calculation can lead to different panel sizes and spacing.

Atlas Concorde KEIL undercut anchor KH

Informative

Verification to wind loads for selective panel sizes and bearing conditions

Annex D 3

Guideline for structural calculation by means of FE - method

For structural calculation by means of the Finite-Element-Method the façade panels are to be idealized with their effective dimensions (size and thickness) as panel elements; the system chosen shall have the capacity to sufficiently precise represent the tension and the deformation state as well as the support reactions of the façade panels. The mesh size at fixing range shall not exceed 10 mm.

The modelling of the façade panel is to be calibrated on the basis of the following points:

- modelling a panel section of 580 mm x 300 mm with a panel thickness of 13,3 mm
- support at the short sides with rotatable restraint
- loading at centre with a single load of 1,33 kN
- determination of a factor $f_{cal,FE} = 41,8 / \sigma_{FE}$
- the determined bending stresses shall be multiplied with factor $f_{cal,FE}$ ($\sigma_{Sk} = \sigma_{FE} \cdot f_{cal,FE}$); the factor $f_{cal,FE}$ shall only be considered for stresses due to support moments

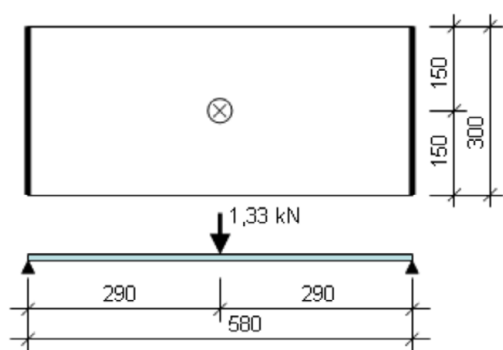

σ_{FE} = maximum main tensile stress [N/mm²]

Atlas Concorde KEIL undercut anchor KH

Informative
Guideline for structural calculation by means of FE - method

Annex D 4