

Approval body for construction products
and types of construction

Bautechnisches Prüfamt

An institution established by the Federal and
Laender Governments



European Technical Assessment

ETA-22/0832
of 8 December 2022

English translation prepared by DIBt - Original version in German language

General Part

Technical Assessment Body issuing the
European Technical Assessment:

Deutsches Institut für Bautechnik

Trade name of the construction product

SV Spiral CARBON

Product family
to which the construction product belongs

Screwed-in plastic anchor for fixing of external thermal
insulation composite systems with rendering in concrete
and masonry

Manufacturer

DAW Italia GmbH & Co KG
Largo R. Murjahn 1
20080 VERMEZZO (MI)
ITALIEN

Manufacturing plant

DAW

This European Technical Assessment
contains

12 pages including 3 annexes which form an integral part
of this assessment

This European Technical Assessment is
issued in accordance with Regulation (EU)
No 305/2011, on the basis of

EAD 330196-01-0604, Edition 10/2017

The European Technical Assessment is issued by the Technical Assessment Body in its official language. Translations of this European Technical Assessment in other languages shall fully correspond to the original issued document and shall be identified as such.

Communication of this European Technical Assessment, including transmission by electronic means, shall be in full. However, partial reproduction may only be made with the written consent of the issuing Technical Assessment Body. Any partial reproduction shall be identified as such.

This European Technical Assessment may be withdrawn by the issuing Technical Assessment Body, in particular pursuant to information by the Commission in accordance with Article 25(3) of Regulation (EU) No 305/2011.

Specific Part

1 Technical description of the product

The screwed-in anchor SV Spiral CABRON consist of an anchor sleeve and a screw plate in different colours, both made of polyamide (virgin material) and an accompanying specific screw of galvanised steel.

The product description is given in Annex A.

2 Specification of the intended use in accordance with the applicable European Assessment Document

The performances given in Section 3 are only valid if the anchor is used in compliance with the specifications and conditions given in Annex B.

The verification and assessment methods on which this European Technical Assessment is based lead to the assumption of a working life of the anchor of at least 25 years. The indications given on the working life cannot be interpreted as a guarantee given by the producer, but are to be regarded only as a means for choosing the right products in relation to the expected economically reasonable working life of the works.

3 Performance of the product and references to the methods used for its assessment

3.1 Safety and accessibility in use (BWR 4)

Essential characteristic	Performance
Characteristic load bearing capacity <ul style="list-style-type: none"> - Characteristic resistance under tension load - Minimum edge distance and spacing 	See Annex C 1 See Annex B 2
Displacements	See Annex C 2
Plate stiffness	No performance assessed

3.2 Energy economy and heat retention (BWR 6)

Essential characteristic	Performance
Point thermal transmittance	See Annex C 2

4 Assessment and verification of constancy of performance (AVCP) system applied, with reference to its legal base

In accordance with EAD No. 330196-01-0604, the applicable European legal act is: [97/463/EC].

The system to be applied is: 2+

5 Technical details necessary for the implementation of the AVCP system, as provided for in the applicable EAD

Technical details necessary for the implementation of the AVCP system are laid down in the control plan deposited with Deutsches Institut für Bautechnik.

The following standards and documents are referred to in this European Technical Assessment:

- EOTA Technical Report TR 025, Edition May 2016 Point Thermal Transmittance of Plastic Anchors for ETICS
- EOTA Technical Report TR 051, Edition April 2018 Job site tests of plastic anchors and screws
- EN 206:2013 Concrete - Specification, performance, production and conformity
- EN 771-1:2011+A1:2015 Specification for masonry units - Part 1: Clay masonry units
- EN 771-2:2011+A1:2015 Specification for masonry units - Part 2: Calcium silicate masonry units
- EN 771-3:2011+A1:2015 Specification for masonry units - Part 3: Aggregate concrete masonry units (Dense and lightweight aggregates)
- EN 771-4:2011+A1:2015 Specification for masonry units - Part 4: Autoclaved aerated concrete masonry units
- EN 1520:2011 Prefabricated reinforced components of lightweight aggregate concrete with open structure
- EN ISO 4042:2018-11 Fasteners - Electroplated coating systems

Issued in Berlin on 8 December 2022 by Deutsches Institut für Bautechnik

Dipl.-Ing. Beatrix Wittstock
Head of Section

beglaubigt:
Aksünger

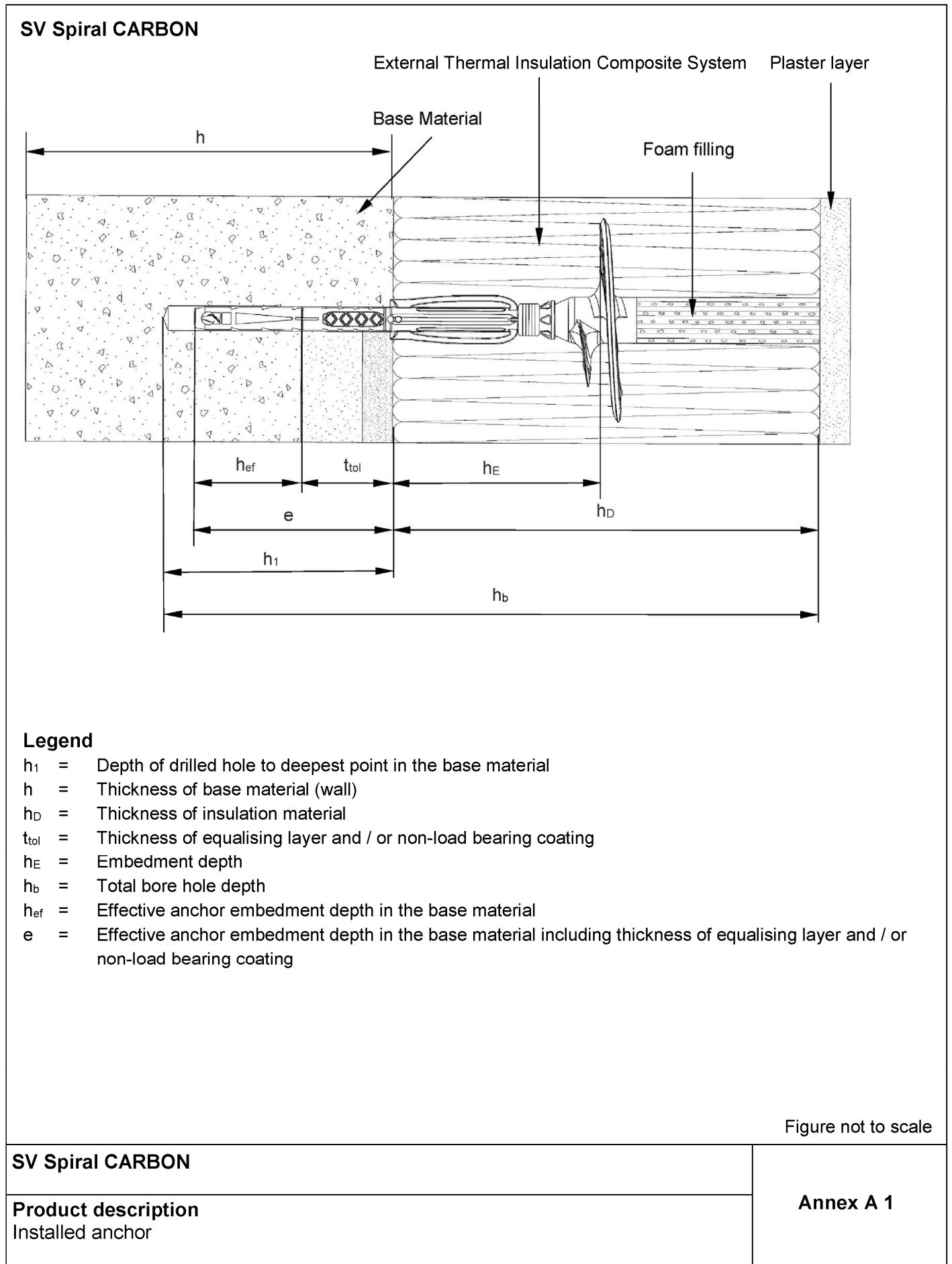

SV Spiral CARBON

Anchor sleeve

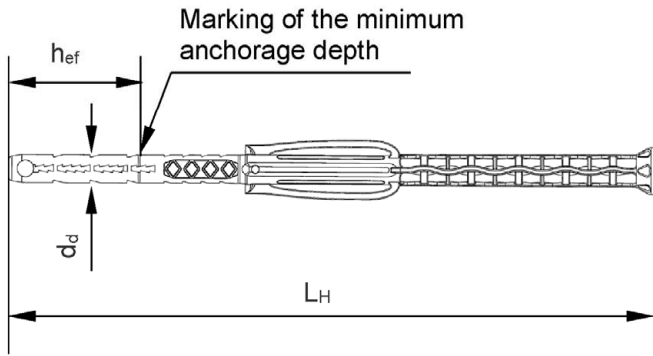

Screw plate

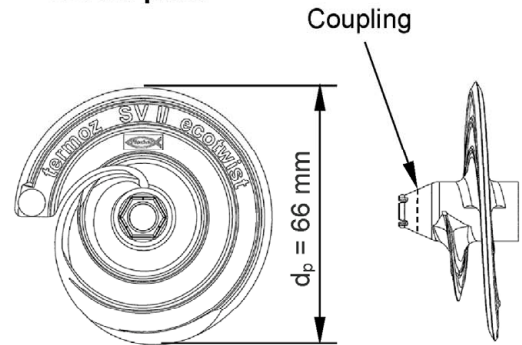

Special screw

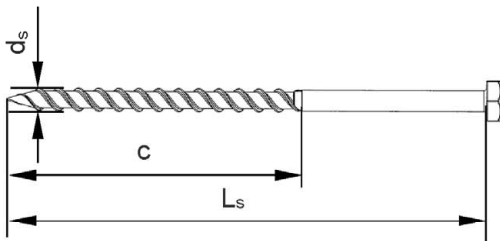

Adjustment of the ring depends on the insulation material thickness, e.g. $h_D = 180 \text{ mm}$
→ adjust value 180 at the setting tool

Setting tool

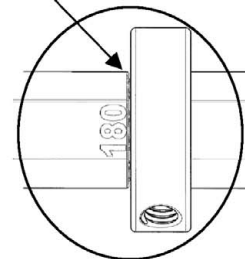
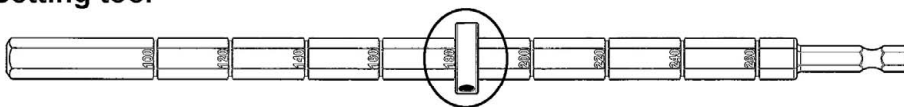

Complete Anchor

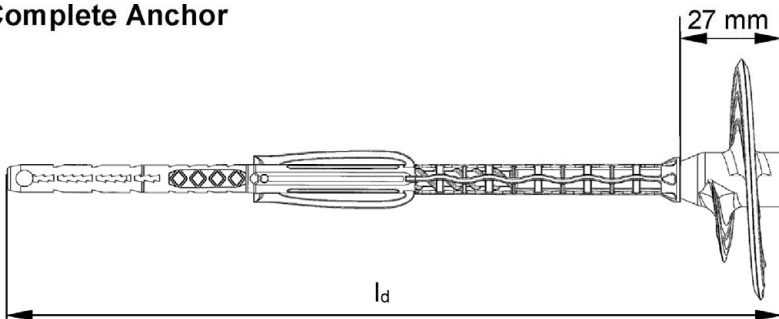

Figures not to scale

SV Spiral CARBON

Product description
Anchor type and single parts

Annex A 2

Table A3.1: Dimensions								
Anchor type	Anchor sleeve				Special screw			
SV Spiral CARBON	d_d	$h_{ef}^{1)}$	$h_E^{1)}$	l_d	L_H	d_s	L_s	c
	[mm]							
t_{tol} 0-10 mm	8	35	70	162	135	6	100	74
t_{tol} 0-30 mm				202	175		120	
t_{tol} 30-60 mm				232	205		150	
1) see Annex A 1.								
Table A3.2: Marking on the screw plate								
Anchor type	Marking							
Name	termoz SV II ecotwist							
Works symbol								
Table A3.2: Marking on the anchor sleeve								
Anchor type	Marking							
SV Spiral CARBON t_{tol} 0-10 mm	t_{tol} 0 - 10							
SV Spiral CARBON t_{tol} 0-30 mm	t_{tol} 0 - 30							
SV Spiral CARBON t_{tol} 30-60 mm	t_{tol} 30 - 60							
Table A3.2: Material								
Designation	Material							
Anchor sleeve	PA6, colour: grey							
Screw plate	PA6 GF, colour: grey, yellow, red, orange, green, blue, mocca-latte, black							
Special screw	Galvanised steel gvz with Zn5/Ag or Zn5/An in accordance with EN ISO 4042							
Insulation plug	Polystyrene, mineral wool							
SV Spiral CARBON								Annex A 3
Product description								
Dimensions anchor types, marking on the screw plate/anchor sleeve Material								

Specifications of intended use

Anchorage subject to:

- The anchor may only be used for transmission of wind suction loads and shall not be used for the transmission of dead loads of the external thermal insulation composite system.

Base materials:

- Normal weight concrete without fibres \geq C12/15 (base material group "A") as per EN 206, see Annex C 1.
- Solid masonry (base material group "B") as per EN 771-1, EN 771-2 or EN 771-3, see Annex C 1.
- Hollow or perforated masonry (base material group "C") as per EN 771-1, EN 771-2 or EN 771-3, see Annex C 1.
- Lightweight aggregate concrete (base material group "D") as per EN 1520, see Annex C 1.
- Autoclaved aerated concrete (base material group "E") as per EN 771-4, see Annex C 1.
- For other base materials of the base material groups "A", "B", "C", "D" and "E" the characteristic resistance of the anchor may be determined by job site tests in accordance with EOTA Technical Report TR 051.

Temperature Range:

- 0 °C to + 40 °C (max. short term temperature + 40 °C and max. long term temperature + 24 °C) of the base material.

Design:

- The anchorages are designed under the responsibility of an engineer experienced in anchorages and masonry work with the partial safety factors for material related resistances $\gamma_M = 2,0$ and for action loads $\gamma_F = 1,5$ in absence of other national regulations.
- Verifiable calculation notes and drawings are prepared taking account of the loads to be anchored. The position of the anchors is indicated on the design drawings.
- Fasteners are only to be used for multiple fixings of external thermal insulation composite systems.

Installation:

- Drilling method according to Annex C 1.
- Anchor installation carried out by appropriately qualified personnel and under the supervision of the person responsible for technical matters on the site.
- Installation temperature from 0 °C to + 40 °C.
- Exposure to UV due to solar radiation of the anchor not protected by rendering \leq 6 weeks.

SV Spiral CARBON

Intended use
Specifications

Annex B 1

Table B2.1: Installation parameters in all regulated base material groups		
Anchor type		SV Spiral CARBON
Drill hole diameter	$d_0 = [\text{mm}]$	8
Cutting diameter of drill bit	$d_{\text{cut}} \leq [\text{mm}]$	8,45
Depth of drill hole to deepest point		
SV Spiral CARBON t_{tol} 0-10 mm	$h_1 \geq [\text{mm}]$	55
SV Spiral CARBON t_{tol} 0-30 mm	$h_1 \geq [\text{mm}]$	75
SV Spiral CARBON t_{tol} 30-60 mm	$h_1 \geq [\text{mm}]$	105
Total bore hole depth at		
SV Spiral CARBON t_{tol} 0-10 mm	$h_b \geq [\text{mm}]$	$h_D + 55$
SV Spiral CARBON t_{tol} 0-30 mm	$h_b \geq [\text{mm}]$	$h_D + 75$
SV Spiral CARBON t_{tol} 30-60 mm	$h_b \geq [\text{mm}]$	$h_D + 105$
Overall plastic anchor embedment depth in the base material including equalising layers / coatings ($h_{\text{ef}} + t_{\text{tol,max}}$) ¹⁾		
SV Spiral CARBON t_{tol} 0-10 mm	$e = [\text{mm}]$	45
SV Spiral CARBON t_{tol} 0-30 mm	$e = [\text{mm}]$	65
SV Spiral CARBON t_{tol} 30-60 mm	$e = [\text{mm}]$	95

¹⁾ see Annex A 1.

Table B2.2: Minimum thickness of member, edge distances and spacing in all regulated base material groups

Anchor type		SV Spiral CARBON
Minimum thickness of member	$h_{\text{min}} = [\text{mm}]$	100 ¹⁾
Minimum spacing	$s_{\text{min}} = [\text{mm}]$	100
Minimum edge distance	$c_{\text{min}} = [\text{mm}]$	100

¹⁾ For weather resistant external wall panels: $h_{\text{min}}=40$ mm.

Scheme of edge distances and spacing
for base material group "A", concrete,
group "B" solid bricks, group "C" hollow or
perforated masonry, group "d" lightweight
aggregate concrete, group "E" autoclaved
aerated concrete

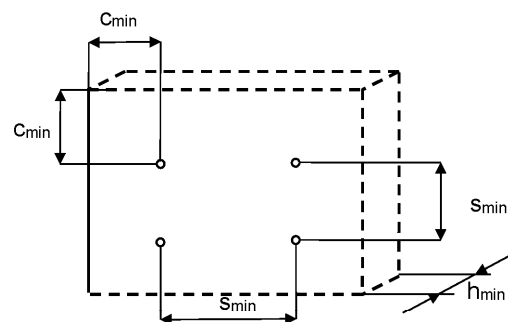
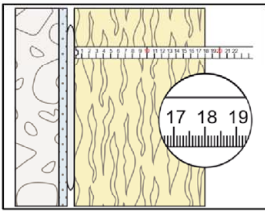

Figure not to scale

SV Spiral CARBON	Annex B 2
Intended use	
Installation Parameters Minimum thickness of member, edge distances and spacing	

Installation instructions



1. Measure insulation thickness h_D (example: 18 cm = 180 mm).

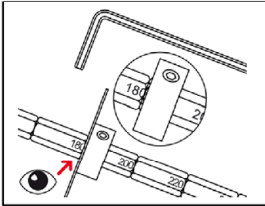

2. Adjust the setting tool ring corresponding to the insulation material thickness h_D in mm. Number is legible. Additionally to the setting tool ring, a thin plastic plate (maximum 1 mm thickness) can be used as a stop unit for easier mounting.

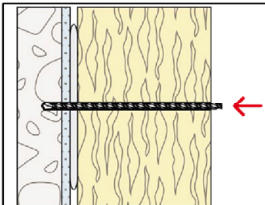

3. Drill bore hole. Total drill hole depth must be at
 $t_{\text{tol}} 0-10 \text{ mm} \rightarrow h_D + 55 \text{ mm}$
 $t_{\text{tol}} 0-30 \text{ mm} \rightarrow h_D + 75 \text{ mm}$
 $t_{\text{tol}} 30-60 \text{ mm} \rightarrow h_D + 105 \text{ mm}.$
 Note: bore holes in Hlz and autoclaved aerated concrete only by rotary drilling.

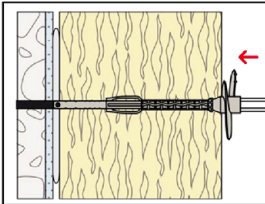

4. Press the anchor with the screw plate tight against the surface of the insulation material, then start screwing-in the anchor. Setting is finished when the surface of the ring is flush with the surface of the insulation material.

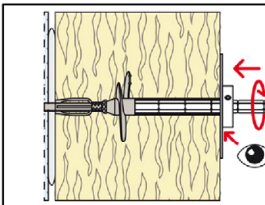

5. After reaching the setting depth, press the adjustment tool tight against the installed anchor. If there is no axial movement of the anchor, remove the setting tool. The setting process is finished.

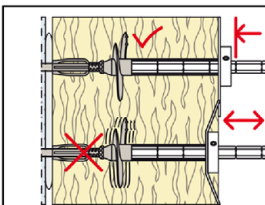

6. In case of axial movement, a new anchor has to be set in a new drill hole.

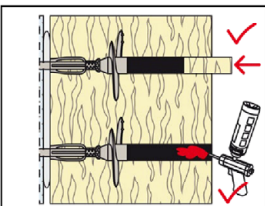

7. The hole in the insulation material must be filled with a suitable foam (illustrated in Annex A 1) or must be closed with an appropriate insulation plug.

SV Spiral CARBON

Intended use
Installation instructions

Annex B 3

Base material	Group	Bulk density ρ [kg/dm ³]	Mean compressive strength / minimum compressive strength single brick as per EN 771 ⁴⁾ [N/mm ²]	Remarks	Drilling method ¹⁾	Characteristic resistance to tension load N_{Rk} [kN]
Weather resistant skin of external wall panels, concrete C20/25 - C50/60 as per EN 206	A	-	-	Thickness of concrete panels 40 mm $\leq h < 100$ mm.	H	0,90
					R	1,50
Concrete C12/15 - C50/60 as per EN 206	A	-	-	-	H	1,50
Solid clay bricks, Mz as per EN 771-1	B ²⁾	$\geq 1,8$	15/12	-	H	1,20
Sand-lime solid bricks, KS as per EN 771-2	B ²⁾	$\geq 2,0$	15/12	-	H	1,20
			25/20			1,50
Solid concrete block, Vbn as per EN 771-3	B ²⁾	$\geq 2,0$	15/12	-	H	1,20
			25/20			1,50
Lightweight concrete solid blocks, Vbl as per EN 771-3	B ²⁾	$\geq 1,4$	10/8	-	H	0,60
Vertically perforated clay bricks, Hlz as per EN 771-1	C ³⁾	$\geq 1,0$	15/12	Exterior web thickness ≥ 12 mm.	R	0,75
Vertically perforated sand-lime bricks, KSL as per EN 771-2	C ³⁾	$\geq 1,4$	15/12	Exterior web thickness ≥ 23 mm.	H	0,75
			25/20			1,20
Lightweight concrete hollow blocks, Hbl as per EN 771-3	C ³⁾	$\geq 1,2$	5/4	Exterior web thickness ≥ 38 mm.	H	0,60
			7,5/6			0,75
			10/8			0,90
			12,5/10			1,20
French lightweight concrete hollow block, Hbl as per EN 771-3 "Sepa Parpaing" 500 x 200 x 190 mm	C ³⁾	$\geq 0,9$	5/4	 <p>Web thickness ≥ 16 mm.</p>	H	0,50
Lightweight aggregate concrete, LAC as per EN 1520	D ³⁾	$\geq 0,9$	7,5/6	Minimum thickness of solid brick $h = 100$ mm or exterior web thickness ≥ 50 mm.	H	0,75
Autoclaved aerated concrete, AAC as per EN 771-4	E	$\geq 0,5$	5/4	-	R	0,40
¹⁾ H = Hammer drilling, R = Rotary drilling. ²⁾ Vertically perforation $\leq 15\%$; cross section reduced by perforation vertically to the resting area. ³⁾ Vertically perforation $> 15\%$ and $\leq 50\%$, cross section reduced by perforation vertically to the resting area. ⁴⁾ The compressive strength of the single brick must not be less than 80% of the mean compressive strength.						
SV Spiral CARBON						Annex C 1
Performances Characteristic resistance to tension load for single anchor						

Table C2.1: Point thermal transmittance according to EOTA Technical Report TR 025

Anchor type	Thickness of insulation material h_D [mm]	Point thermal transmittance χ [W/K]
SV Spiral CARBON EPS-plug and air void $t_{tol} = 0-10$ mm	100 - 240	0,001
	> 240	0
SV Spiral CARBON PU-foam filled hole $t_{tol} = 0-10$ mm	100 - 150	0,001
	> 150	0
SV Spiral CARBON EPS-plug and air void $t_{tol} = 0-30$ mm	100 - 240	0,001
	> 240	0
SV Spiral CARBON PU-foam filled hole $t_{tol} = 0-30$ mm	100 - 150	0,001
	> 150	0
SV Spiral CARBON EPS-plug and air void $t_{tol} = 30-60$ mm	100	0,002
	120 - 240	0,001
	> 240	0
SV Spiral CARBON PU-foam filled hole $t_{tol} = 30-60$ mm	100	0,002
	120 - 150	0,001
	> 150	0

Table C2.2: Displacements for SV Spiral CARBON

Base material		Mean compressive strength / minimum compressive strength single brick as per EN 771 ¹⁾ [N/mm ²]	Tension load N [kN]	Displacements $\Delta\delta_N$ [mm]
Concrete, thin members C20/25 - C50/60 as per EN 206	Hammer drilling	-	0,30	< 0,30
	Rotary drilling	-	0,50	< 0,30
Concrete, C16/20 - C50/60 as per EN 206		-	0,50	< 0,30
Clay bricks, Mz as per EN 771-1		15/12	0,40	< 0,30
Sand-lime solid bricks, KS as per EN 771-2		15/12	0,40	< 0,30
		25/20	0,50	
Solid concrete block, Vbn as per EN 771-3		15/12	0,40	< 0,30
		25/20	0,50	
Lightweight concrete solid blocks, Vbl as per EN 771-3		10/8	0,20	< 0,20
Vertically perforated clay bricks, Hlz as per EN 771-1		15/12	0,25	< 0,30
Vertically perforated sand-lime bricks, KSL as per EN 771-2		15/12	0,25	< 0,20
		25/20	0,40	
Lightweight concrete hollow blocks, Hbl as per EN 771-3		5/4	0,20	< 0,30
		7,5/6	0,25	
		10/8	0,30	
		12/10	0,40	
Lightweight concrete hollow blocks, Hbl as per EN 771-3		5/4	0,15	< 0,40
Lightweight aggregate concrete, LAC as per EN 1520		7,5/6	0,25	< 0,20
Autoclaved aerated concrete blocks, AAC as per EN 771-4		5/4	0,15	< 0,10

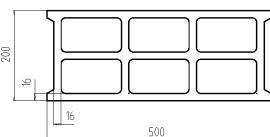
¹⁾ The compressive strength of the single brick must not be less than 80% of the mean compressive strength.

SV Spiral CARBON	Annex C 2
Performances	
Point thermal transmittance Displacements	