

Approval body for construction products
and types of construction

Bautechnisches Prüfamt

An institution established by the Federal and
Laender Governments



European Technical Assessment

ETA-18/0163
of 16 March 2023

English translation prepared by DIBt - Original version in German language

General Part

Technical Assessment Body issuing the
European Technical Assessment:

Deutsches Institut für Bautechnik

Trade name of the construction product

KVT staples type A d = 1.5 mm, type B d = 1.8 mm and
type C d = 2.0 mm galvanized or made of stainless steel
with resin coating

Product family
to which the construction product belongs

Dowel-type fasteners with resin coating

Manufacturer

Knoll Verbindungstechnik
GmbH & Co. KG
Industriestraße 67-69
32120 Hiddenhausen
DEUTSCHLAND

Manufacturing plant

Knoll Verbindungstechnik
GmbH & Co. KG
Industriestraße 67-69
32120 Hiddenhausen
DEUTSCHLAND

This European Technical Assessment
contains

15 pages including 3 annexes which form an integral part
of this assessment

This European Technical Assessment is
issued in accordance with Regulation (EU)
No 305/2011, on the basis of

EAD 130019-00-0603 – DOWEL-TYPE FASTENERS
WITH RESIN COATING

This version replaces

ETA-18/0163 issued on 19 October 2018

The European Technical Assessment is issued by the Technical Assessment Body in its official language. Translations of this European Technical Assessment in other languages shall fully correspond to the original issued document and shall be identified as such.

Communication of this European Technical Assessment, including transmission by electronic means, shall be in full. However, partial reproduction may only be made with the written consent of the issuing Technical Assessment Body. Any partial reproduction shall be identified as such.

This European Technical Assessment may be withdrawn by the issuing Technical Assessment Body, in particular pursuant to information by the Commission in accordance with Article 25(3) of Regulation (EU) No 305/2011.

Specific Part

1 Technical description of the product

KVT staples type A $d = 1.5$ mm, type B $d = 1.8$ mm and type C $d = 2.0$ mm are dowel-type fasteners made of non-alloy steel rods in accordance with EN ISO 16120¹ or made of stainless steel drawn from austenitic steel rods in accordance with EN 10088-1² for timber constructions. The staples have a special resin coating with a minimum length of 50 % of the legs.

The nominal diameters of the staple legs of type A are $d = 1.53$ mm \pm 0.03 mm, of type B $d = 1.80$ mm \pm 0.03 mm and of type C $d = 2.03$ mm \pm 0.03 mm. Further dimensions are shown in Annex 1.

2 Specification of the intended use in accordance with the applicable European Assessment Document

The performances given in Section 3 are only valid if the KVT staples type A $d = 1.5$ mm, type B $d = 1.8$ mm and type C $d = 2.0$ mm are used in compliance with the specifications and conditions given in Annex 2 and 3.

The verifications and assessment methods on which this European Technical Assessment is based lead to the assumption of a working life of KVT staples of at least 50 years. The indications given on the working life cannot be interpreted as a guarantee given by the producer, but are to be regarded only as a means for choosing the right products in relation to the expected economically reasonable working life of the works.

3 Performance of the product and references to the methods used for its assessment

3.1 Mechanical resistance and stability (BWR 1)

Essential characteristic	Performance
Dimensions	See Annex 1
Characteristic yield moment	See Annex 3
Characteristic withdrawal parameter for short-term and medium-term loads	See Annex 3
Withdrawal capacity for long-term and permanent loads	See Annex 3
Characteristic head pull-through parameter	See Annex 3
Minimum tensile strength of the wire	See Annex 3
Minimum and maximum thickness of the connected material	See Annex 3
Durability against corrosion	See Annex 2
Durability of the resin coating	See Annex 2

¹ EN ISO 16120:2017

² EN 10088-1:2014

Non-alloy steel wire rod for conversion to wire (all parts)

Stainless steel – Part 1: List of stainless steels

3.2 Safety in case of fire (BWR 2)

Essential characteristic	Performance
Reaction to fire	Class A1

3.3 Safety and accessibility in use (BWR 4)

The essential characteristics of BWR 4 are covered by BWR 1.

4 Assessment and verification of constancy of performance (AVCP) system applied, with reference to its legal base

In accordance with EAD No. 130019-00-0603, the applicable European legal act is: 97/176/EC.
The system to be applied is: 3

5 Technical details necessary for the implementation of the AVCP system, as provided for in the applicable EAD

Technical details necessary for the implementation of the AVCP system are laid down in the control plan deposited with Deutsches Institut für Bautechnik.

Issued in Berlin on 16 March 2023 by Deutsches Institut für Bautechnik

Anja Dewitt
Head of Section

beglaubigt:
Blümel

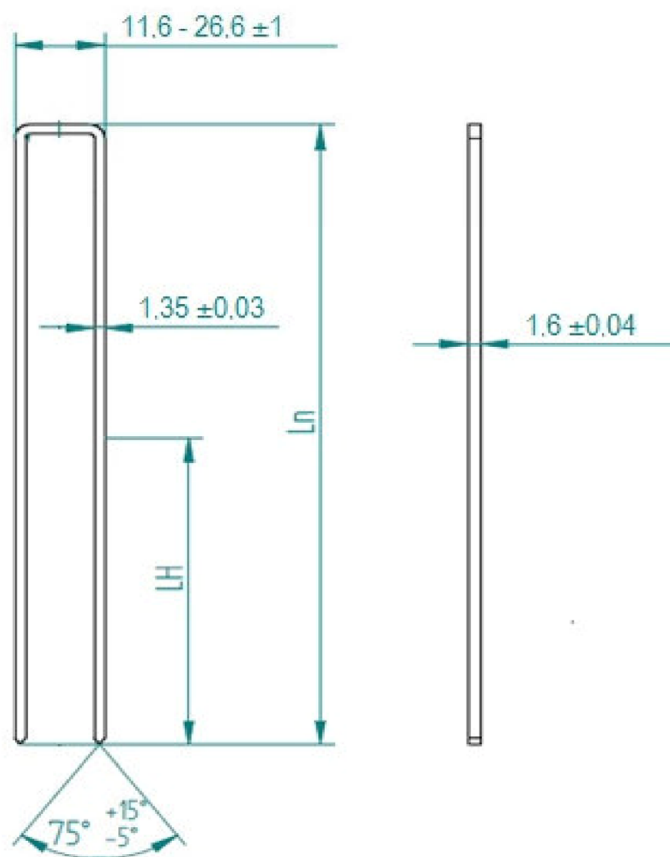

Leg length Ln (mm)	32,0 bis 90,0	Combined glue/resin KVT-Harz Nr. 1 or 2
Resin coating LH (mm)	min.0,5 Ln >= 25 mm	
Staple raw wire	<u>Technical description</u>	
Round galvanized steel	KVT staples type - A	
Zinc: 12µ		
Tensile strength >= 900 N/mm ²		
Ø 1,53 ± 0,03 mm		
Knoll Verbindungstechnik GmbH & CO.KG Industriestr. 67-69 32120 Hiddenhausen		

KVT staples type A d = 1.5 mm, type B d = 1.8 mm and type C d = 2.0 mm galvanized or made of stainless steel with resin coating

KVT staples type A d = 1.5 mm - galvanized

Annex 1.1

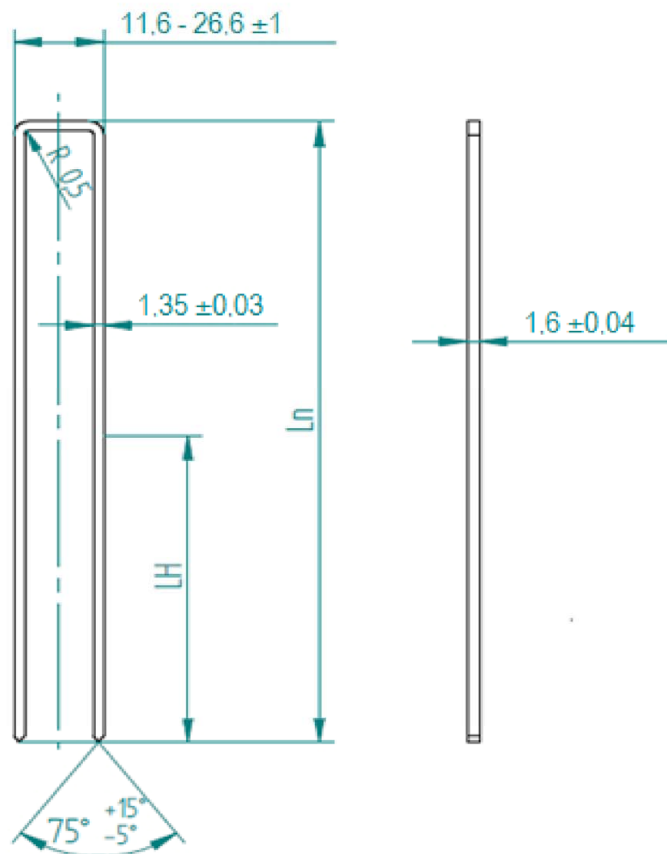

Leg length L_n (mm)	32,0 bis 90,0	Combined glue/resin KVT-Harz Nr. 1
Resin coating L_H (mm)	min.0,5 $L_n \geq 25$ mm	
Staple raw wire	Technical description	
Round stainless steel	KVT staples type - A	
AISI 304 1.4301		
AISI 316 1.4401		
Tensile strength ≥ 900 N/mm ²		
$\varnothing 1,53 \pm 0,03$ mm		
Knoll Verbindungstechnik GmbH & CO.KG Industriestr. 67-69 32120 Hiddenhausen		

KVT staples type A $d = 1.5$ mm, type B $d = 1.8$ mm and type C $d = 2.0$ mm galvanized or made of stainless steel with resin coating

KVT staples type A $d = 1.5$ mm - stainless steel

Annex 1.2

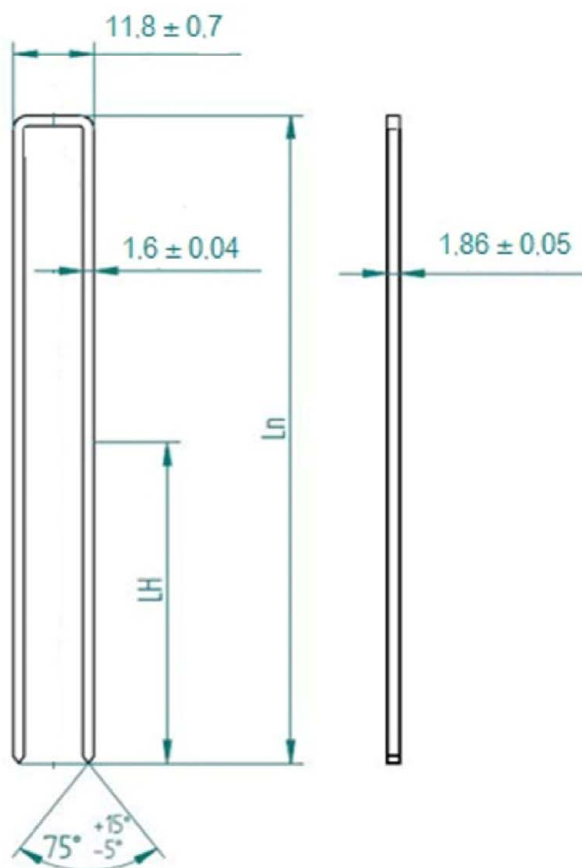

Leg length Ln (mm)	38,0 bis 100,0
Resin coating LH (mm)	min.0,5 Ln \geq 25 mm
Staple raw wire	Technical description
Round galvanized steel	KVT staples type - B
Zinc: 12 μ	
Tensile strength \geq 900 N/mm ²	
\varnothing 1,80 \pm 0,03 mm	
Knoll Verbindungstechnik GmbH & CO.KG Industriestr. 67-69 32120 Hiddenhausen	

Combined glue/resin
KVT-Harz Nr. 1 or 2

Electronic copy of the ETA by DIBt: ETA-18/0163

KVT staples type A d = 1.5 mm, type B d = 1.8 mm and type C d = 2.0 mm galvanized or made of stainless steel with resin coating

KVT staples type B d = 1.8 mm - galvanized

Annex 1.3

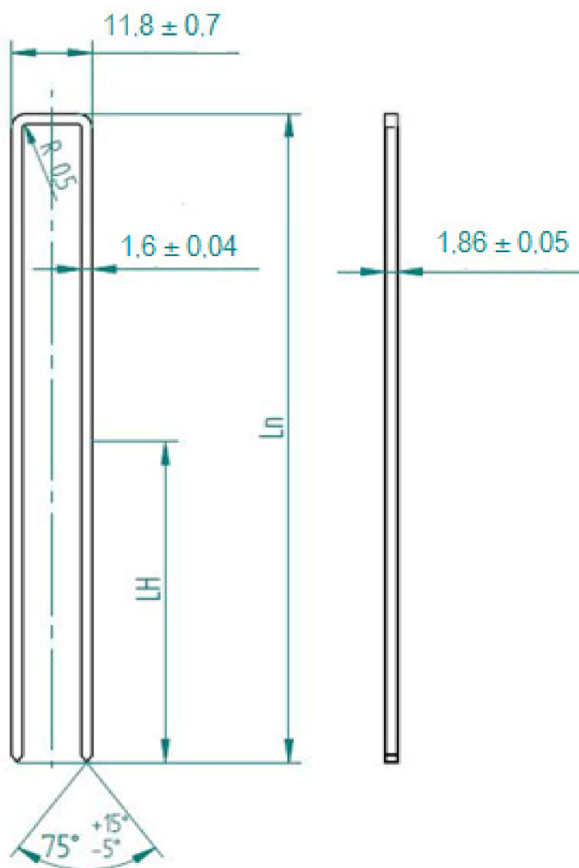

Leg length Ln (mm)	38,0 bis 100,0	Combined glue/resin KVT-Harz Nr. 1
Resin coating LH (mm)	min.0,5 Ln \geq 25 mm	
Staple raw wire	Technical description	
Round stainless steel	KVT staples type - B	
AISI 304 1.4301		
AISI 316 1.4401		
Tensile strength \geq 900 N/mm ²		
\varnothing 1,80 \pm 0,03 mm		
Knoll Verbindungstechnik GmbH & CO.KG Industriestr. 67-69 32120 Hiddenhausen		

KVT staples type A d = 1.5 mm, type B d = 1.8 mm and type C d = 2.0 mm galvanized or made of stainless steel with resin coating

KVT staples type B d = 1.8 mm - stainless steel

Annex 1.4

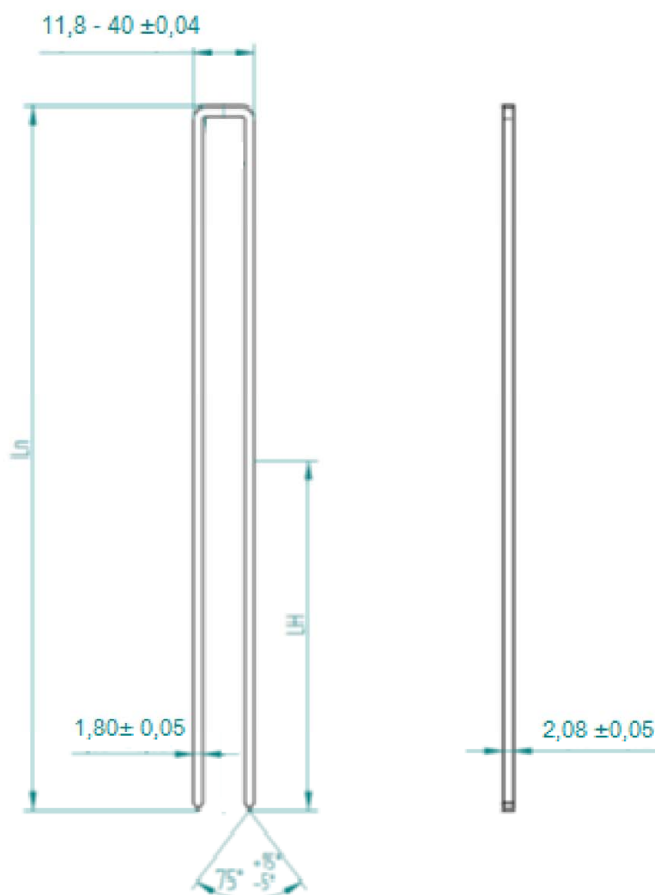

Leg length L_n (mm)	40,00 - 170,00
Resin coating L_H (mm)	min.0,5 $L_n \geq 25$ mm
Staple raw wire	Technical description
Round galvanized steel	KVT staples type - C
Zinc: 12 μ	
Tensile strength ≥ 900 N/mm ²	
$\varnothing 2,03 \pm 0,03$ mm	
Knoll Verbindungstechnik GmbH & CO.KG Industriestr. 67-69 32120 Hiddenhausen	

Combined glue/resin
KVT-Harz Nr. 1 or 2

Electronic copy of the ETA by DIBt: ETA-18/0163

KVT staples type A $d = 1.5$ mm, type B $d = 1.8$ mm and type C $d = 2.0$ mm galvanized or made of stainless steel with resin coating

KVT staples type C $d = 2.0$ mm - galvanized

Annex 1.5

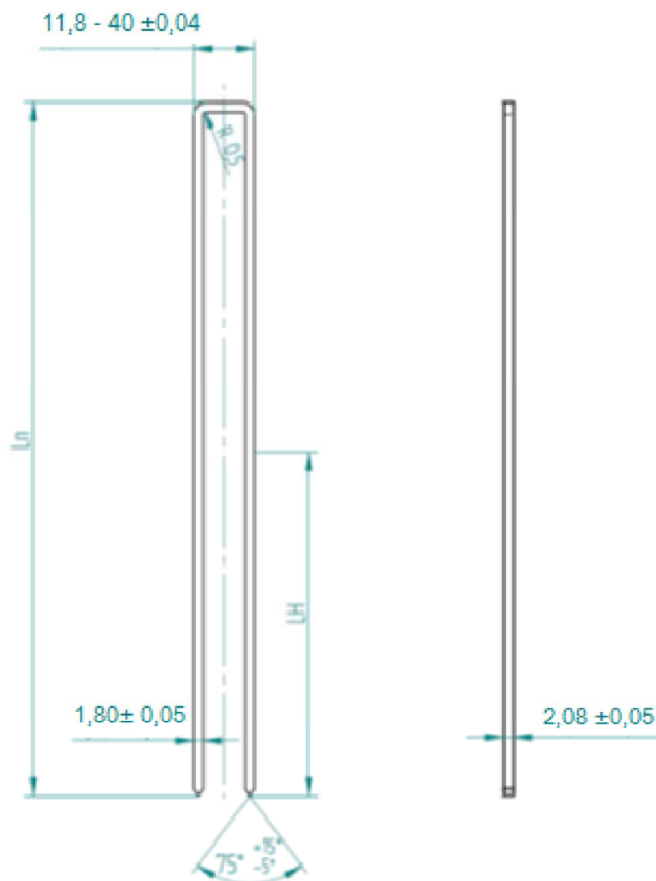

Leg length L_n (mm)	40,00 - 170,00	Combined glue/resin KVT-Harz Nr. 1
Resin coating L_H (mm)	min.0,5 $L_n \geq 25$ mm	
Staple raw wire	Technical description	
Round stainless steel	KVT staples type - C	
AISI 304 1.4301		
AISI 316 1.4401		
Tensile strength ≥ 900 N/mm ²		
$\varnothing 2,03 \pm 0,03$ mm		
Knoll Verbindungstechnik GmbH & CO.KG Industriestr. 67-69 32120 Hiddenhausen		

KVT staples type A $d = 1.5$ mm, type B $d = 1.8$ mm and type C $d = 2.0$ mm galvanized or made of stainless steel with resin coating

KVT staples type C $d = 2.0$ mm - stainless steel

Annex 1.6

Annex 2 Specifications of intended use

A.2.1 Loading

- Static and quasi-static loads (not relevant to fatigue)
- Short-, medium-, long-term and permanent load duration withdrawal as well as lateral loading

A.2.2 Connection material

KVT staples type A d = 1.5 mm, type B d = 1.8 mm and type C d = 2.0 mm are used for load-bearing connections of the following materials.

Material for base building components

- Solid timber (softwood) in accordance with EN 14081-1¹,
- Glued laminated timber in accordance with EN 14080²,
- Glued solid timber in accordance with EN 14080,
- Laminated veneer lumber LVL (softwood) in accordance with EN 14374³,
- Cross laminated timber (softwood) in accordance with European Technical Assessments.

Material for connected components

- Oriented strand boards (OSB) in accordance with EN 300⁴ and EN 13986⁵,
- Plywood in accordance with EN 636⁶ and EN 13986,
- Cement-bonded particleboards in accordance with EN 634-2⁷ and EN 13986,
- Fibreboards in accordance with EN 622-2⁸, EN 622-3⁹ and EN 13986,
- Laminated veneer lumber LVL in accordance with EN 13986 in connection with EN 14279¹⁰,
- Solid wood panels (SWP) in accordance with EN 13353¹¹ and EN 13986,
- Gypsum plasterboards in accordance with EN 520¹², density $\rho \geq 680 \text{ kg/m}^3$, including Type D with a density of $\rho \geq 800 \text{ kg/m}^3$,
- Gypsum boards with mat reinforcement and gypsum fibre boards in accordance with EN 15283-1¹³ and EN 15283-2¹⁴,
- Fibre-cement flat sheets in accordance with EN 12467¹⁵,
- Wood fibre insulation material in accordance with EN 13171¹⁶.

1	EN 14081-1:2005+A1:2011	Timber structures – Strength graded structural timber with rectangular cross section – Part 1: General requirements
2	EN 14080:2013	Timber structures – Glued laminated timber and glued solid timber – Requirements
3	EN 14374:2004	Timber structures – Structural laminated veneer lumber – Requirements
4	EN 300:2006	Oriented strand boards (OSB) – Definition, classification and specifications
5	EN 13986:2004+A1:2015	Wood-based panels for use in construction – Characteristics, evaluation of conformity and marking
6	EN 636:2012+A1:2015	Plywood – Specifications
7	EN 634-2:2007	Cement-bonded particleboards – Specifications – Part 2: Requirements for OPC bonded particleboards for use in dry, humid and external conditions
8	EN 622-2:2004/AC:2005	Fibreboards – Specifications – Part 2: Requirements for hardboards
9	EN 622-3:2004	Fibreboards – Specifications – Part 3: Requirements for medium boards
10	EN 14279:2004+A1:2009	Laminated Veneer Lumber (LVL) – Definitions, classification and specifications
11	EN 13353:2008+A1:2011	Solid wood panels (SWP) – Requirements
12	EN 520:2004+A1:2009	Gypsum plasterboards – Definitions, requirements and test methods
13	EN 15283-1:2008+A1:2009	Gypsum boards with fibrous reinforcement – Definitions, requirements and test methods – Part 1: Gypsum boards with mat reinforcement
14	EN 15283-2:2008+A1:2009	Gypsum boards with fibrous reinforcement – Definitions, requirements and test methods – Part 2: Gypsum fibre boards
15	EN 12467:2012+A1:2016+A2:2018	Fibre-cement flat sheets – Product specification and test methods
16	EN 13171:2012+A1:2015	Thermal insulation products for buildings – Factory made wood fibre (WF) products – Specification

KVT staples type A d = 1.5 mm, type B d = 1.8 mm and type C d = 2.0 mm galvanized or made of stainless steel with resin coating	Annex 2.1
Specification of intended use	

A.2.3 Use conditions (environmental conditions)

A.2.3.1 Durability against corrosion

KVT staples type A $d = 1.5$ mm, type B $d = 1.8$ mm and type C $d = 2.0$ mm made of non-alloy steel rods are galvanized. The mean thickness of the zinc coating is $12 \mu\text{m}$. Steel no. 1.4301 and 1.4401 is used for KVT staples type A $d = 1.5$ mm, type B $d = 1.8$ mm and type C $d = 2.0$ mm made of stainless steel.

A.2.3.2 Durability of the resin coating

The resin coating of KVT staples type A $d = 1.5$ mm, type B $d = 1.8$ mm and type C $d = 2.0$ mm has a minimum length l_H of 50 % of the legs in accordance with Annex 1. The following kind of resin is used:

Combined glue/resin KVT-Harz Nr. 1

Combined glue/resin KVT-Harz Nr. 2

Data sheets of chemical compositions (as well as the process of application and drying for resin coatings) are deposited at Deutsches Institut für Bautechnik.

The resin coating fulfills the requirements of the EAD 130019-00-0603, clause 2.2.9 "durability of the resin coating".

A.2.3.3 Installation

EN 1995-1-1¹⁷ applies for the installation of constructions with KVT staples type A $d = 1.5$ mm, type B $d = 1.8$ mm and type C $d = 2.0$ mm.

The pointside penetration length t_2 of the staples is at least $14 \cdot d$.

For connections of wood fibre insulation material, the maximum length of the leg is $l = 85 \cdot d$, the minimum width is $b = 20$ mm and the maximum thickness of the insulation is $70 \cdot d$.

¹⁷ EN 1995-1-1:2004/AC:2006 +A1:2008+A2:2014 Eurocode 5: Design of timber structures – Part 1-1: General – Common rules and rules for buildings

KVT staples type A $d = 1.5$ mm, type B $d = 1.8$ mm and type C $d = 2.0$ mm galvanized or made of stainless steel with resin coating	Annex 2.2
Specification of intended use	

Annex 3 Specifications of essential characteristics

A.3.1 Characteristic yield moment

Table A.3.1 Characteristic yield moment $M_{y,k}$ of one leg of KVT staples
type A $d = 1.5$ mm, type B $d = 1.8$ mm and type C $d = 2.0$ mm

Type	Nominal diameter d [mm]	Characteristic yield moment $M_{y,k}$ [Nm]	
		galvanized	stainless steel
"A" galvanized	1.53	0.54	-
"A" stainless steel		-	0.62
"B" galvanized	1.80	0.87	-
"B" stainless steel		-	0.96
"C" galvanized	2.03	1.02	-
"C" stainless steel		-	1.23

A.3.2 Characteristic withdrawal parameter for short-term and medium-term loads

The characteristic withdrawal parameter $f_{ax,k}$ of one leg (at an angle of at least 30° between the width of staple crown and the direction of the grain) of the KVT staples for material with a characteristic density $\rho_k \geq 350$ kg/m³ as well as for short-term and medium-term withdrawal loads shall be taken from Table A.3.2.

Table A.3.2 Characteristic withdrawal parameter $f_{ax,k}$ of one leg of KVT staples
type A $d = 1.5$ mm, type B $d = 1.8$ mm and type C $d = 2.0$ mm

Type	Nominal diameter d [mm]	Withdrawal parameter for short- and medium-term loads $f_{ax,k}$ [N/mm ²]	
		galvanized	stainless steel
"A" galvanized	1.53	5.4	-
"A" stainless steel		-	7.2
"B" galvanized	1.80	5.3	-
"B" stainless steel		-	8.9
"C" galvanized	2.03	6.3	-
"C" stainless steel		-	7.2

The withdrawal parameters given in Table A.3.2 have been determined for a maximum length of staples in the base building components of $14 \cdot d \leq t_2 \leq 20 \cdot d$.

A.3.3 Design value of withdrawal capacity for long-term and permanent loads

The design value of withdrawal capacity for long-term and permanent loads for service class 1 and 2 for one staple may be taken to:

$$R_{ax,d} = 70 \text{ N, mit } \gamma_M = 1.3.$$

The design value of withdrawal capacity applies for a characteristic density of $\rho_k \geq 350$ kg/m³.

KVT staples type A $d = 1.5$ mm, type B $d = 1.8$ mm and type C $d = 2.0$ mm galvanized or made of stainless steel with resin coating	Annex 3.1
Specifications of essential characteristics	

A.3.4 Maximum thickness of the connected components

The maximum thickness t_1 given in Table A.3.3 applies for connected components (made of material described in Annex A.2.2) depending on the density of the connected components.

Table A.3.3 Maximum thickness t_1 of the connected components

Maximum thickness t_1 [mm]	Range of density ρ_k [kg/m ³]	Material of connected components Examples
80	$\rho_k \leq 400$	Solid timber (softwood)
60	$400 < \rho_k \leq 650$	Wood-based panels
40	$650 < \rho_k \leq 900$	Wood-based panels and gypsum boards
25	$900 < \rho_k \leq 1200$	Hardboards, gypsum fibre boards, cement-bonded particleboards
20	$1200 < \rho_k \leq 1600$	Highly compressed gypsum fibre boards

The maximum thickness of wood fibre insulation material is $t_1 \leq 70 \cdot d$.

A.3.5 Characteristic head pull-through parameter of wood and wood-based panels

The characteristic head pull-through parameter $f_{head,k}$ for one staple of KVT staples type A $d = 1.5$ mm, type B $d = 1.8$ mm and type C $d = 2.0$ mm for a minimum thickness of material given in Table A.3.4 (for material with a characteristic density of $\rho_k \geq 350$ kg/m³) shall be taken from Table A.3.5.

Table A.3.4 Minimum thickness t_1 of wood and wood-based panels

Wood or wood-based panels	Minimum thickness t_1 [mm]
Solid timber (softwood)	24
Solid wood panels (SWP)	$7d^*$
Plywood	6^*
Oriented strand boards (OSB)	8^*
Resin-bonded particleboards	8^*
Cement-bonded particleboards	8^*

* if staple crown is countersunk it has to be increased by 2 mm

The characteristic head pull-through capacity may be calculated with equation (1).

$$R_{ax,2,k} = f_{head,k} \cdot b \cdot d \quad [N] \quad (1)$$

with:

$f_{head,k}$: characteristic head pull-through parameter in N/mm²

b : width of staple crown in mm, $b \leq 27$ mm

d : nominal diameter of raw wire of the staple in mm

KVT staples type A $d = 1.5$ mm, type B $d = 1.8$ mm and type C $d = 2.0$ mm galvanized or made of stainless steel with resin coating	Annex 3.2
Specifications of essential characteristics	

Table A.3.5 Characteristic head pull-through parameter $f_{\text{head,k}}$ for material $\rho_k \geq 350 \text{ kg/m}^3$, $b \leq 27 \text{ mm}$

Type	Nominal diameter d [mm]	Width of staple crown b [mm]	Head pull-through parameter $f_{\text{head,k}}$ [N/mm ²]
"A" galvanized	1.53	11.6	47
"A" stainless steel		26.6	36
"B" galvanized, "B" stainless steel	1.80	11.8	41
"C" galvanized	2.03	11.8	25.5
"C" stainless steel		26.8	34

A.3.6 Characteristic head pull-through parameter of wood fibre insulation material

The characteristic head pull-through parameter $f_{\text{head,k}}$ of KVT staples type C with $d = 2.0 \text{ mm}$ (width of staple crown $b_{\text{min}} = 26,8 \text{ mm}$) for wood fibre insulation material with a mean density of at least 190 kg/m^3 and a minimum thickness of the material of 60 mm is $f_{\text{head,k}} = 8.92 \text{ N/mm}^2$ for one staple.

A.3.7 Minimum tensile strength of the wire

Table A.3.6 Minimum tensile strength f_u [N/mm²] of the raw wire of KVT staples type A $d = 1.5 \text{ mm}$, type B $d = 1.8 \text{ mm}$ and type C $d = 2.0 \text{ mm}$

Nominal diameter d [mm]	1.53	1.80	2.03
galvanized	900		
stainless steel	900		

KVT staples type A $d = 1.5 \text{ mm}$, type B $d = 1.8 \text{ mm}$ and type C $d = 2.0 \text{ mm}$ galvanized or made of stainless steel with resin coating	Annex 3.3
Specifications of essential characteristics	