

Approval body for construction products
and types of construction

Bautechnisches Prüfamt

An institution established by the Federal and
Laender Governments



European Technical Assessment

ETA-21/0168
of 21 July 2023

English translation prepared by DIBt - Original version in German language

General Part

Technical Assessment Body issuing the
European Technical Assessment:

Deutsches Institut für Bautechnik

Trade name of the construction product

Capsule Adhesive Anchor W-VPZ

Product family
to which the construction product belongs

Bonded anchor for use in concrete

Manufacturer

Adolf Würth GmbH & Co. KG
Reinhold-Würth-Straße 12-17
74653 Künzelsau
DEUTSCHLAND

Manufacturing plant

Werk 1

This European Technical Assessment
contains

22 pages including 3 annexes which form an integral part
of this assessment

This European Technical Assessment is
issued in accordance with Regulation (EU)
No 305/2011, on the basis of

330499-01-0601, Edition 04/2020

This version replaces

ETA-21/0168 issued on 1 June 2021

The European Technical Assessment is issued by the Technical Assessment Body in its official language. Translations of this European Technical Assessment in other languages shall fully correspond to the original issued document and shall be identified as such.

Communication of this European Technical Assessment, including transmission by electronic means, shall be in full. However, partial reproduction may only be made with the written consent of the issuing Technical Assessment Body. Any partial reproduction shall be identified as such.

This European Technical Assessment may be withdrawn by the issuing Technical Assessment Body, in particular pursuant to information by the Commission in accordance with Article 25(3) of Regulation (EU) No 305/2011.

Specific Part

1 Technical description of the product

The "Chemical Anchor W-VPZ" is a bonded fastener consisting of a resin anchor capsule W-VPZ and an anchor rod W-VD-A or an internally threaded anchor rod W-VP-IG.

The resin anchor capsule W-VPZ is placed in the hole and the anchor rod W-VD-A or the internally threaded anchor rod W-VP-IG is driven by machine as specified in Annex B6 and B7.

The product description is given in Annex A.

2 Specification of the intended use in accordance with the applicable European Assessment Document

The performances given in Section 3 are only valid if the fastener is used in compliance with the specifications and conditions given in Annex B.

The verifications and assessment methods on which this European Technical Assessment is based lead to the assumption of a working life of the fastener of at least 50 years. The indications given on the working life cannot be interpreted as a guarantee given by the producer, but are to be regarded only as a means for choosing the right products in relation to the expected economically reasonable working life of the works.

3 Performance of the product and references to the methods used for its assessment

3.1 Mechanical resistance and stability (BWR 1)

Essential characteristic	Performance
Characteristic resistance to tension load (static and quasi-static loading)	See Annex B2, B3, C1, C2 and C5
Characteristic resistance to shear load (static and quasi-static loading)	See Annex C1, C3, C6
Displacements under short-term and long-term loading	See Annex C7
Characteristic resistance for seismic performance category C1	See Annex C4
Characteristic resistance and displacements for seismic performance category C2	No performance assessed

3.2 Hygiene, health and the environment (BWR 3)

Essential characteristic	Performance
Content, emission and/or release of dangerous substances	No performance assessed

4 Assessment and verification of constancy of performance (AVCP) system applied, with reference to its legal base

In accordance with the European Assessment Document EAD 330499-01-0601 the applicable European legal act is: [96/582/EC].

The system to be applied is: 1

5 Technical details necessary for the implementation of the AVCP system, as provided for in the applicable European Assessment Document

Technical details necessary for the implementation of the AVCP system are laid down in the control plan deposited at Deutsches Institut für Bautechnik.

Issued in Berlin on 21 July 2023 by Deutsches Institut für Bautechnik

Dipl.-Ing. Beatrix Wittstock
Head of Section

beglaubigt:
Baderschneider

Installation situation Chemical Anchor W-VPZ with anchor rod W-VD-A
(optional annular gap filled with mortar)

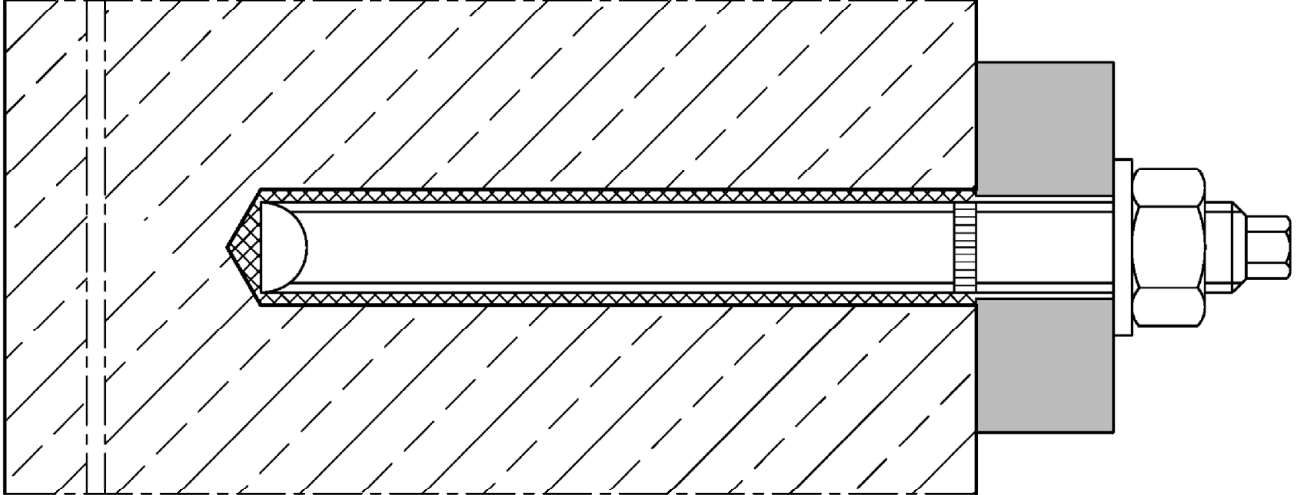

Installation situation Chemical Anchor W-VPZ with Internally threaded anchor rod W-VP-IG ¹⁾ (optional annular gap filled with mortar)

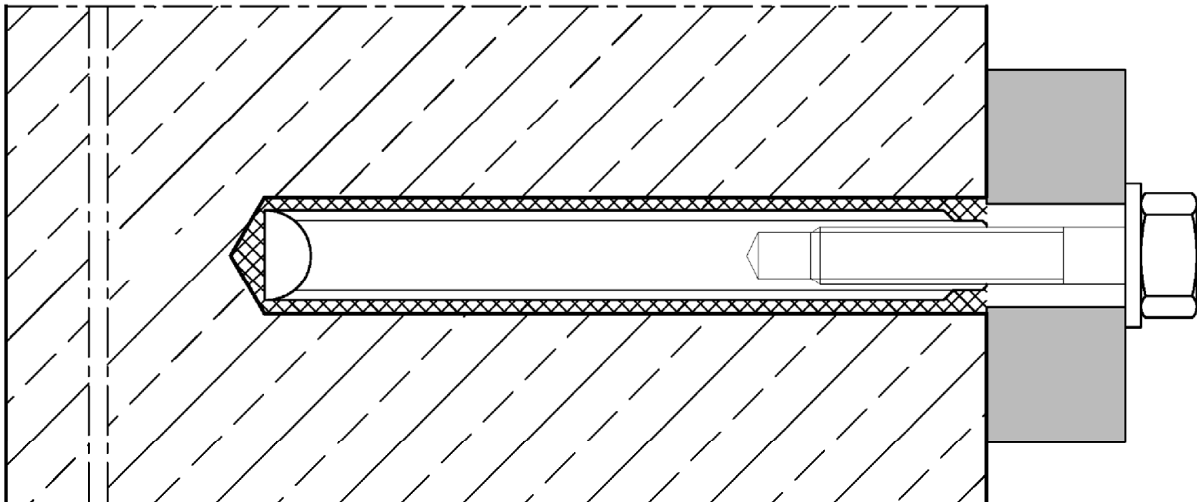





¹⁾ Illustration exemplary with hexagon head screw; fastening also possible with other screws or with threaded rods.

Chemical Anchor W-VPZ

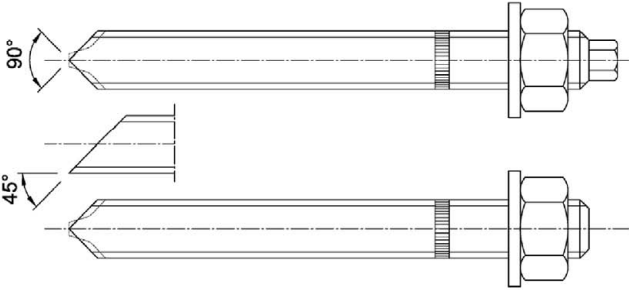
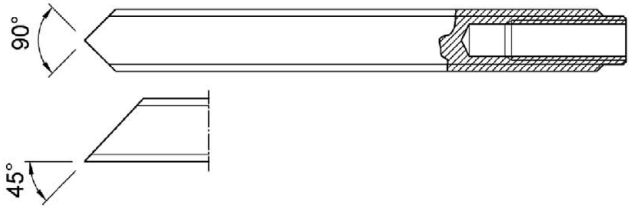
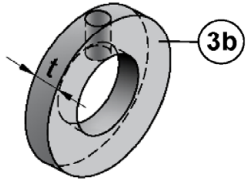
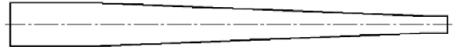
Product description
Installation situation

Annex A1

Resin Anchor Capsule W-VPZ	
	
Anchor rod W-VD-A	Internally threaded anchor rod W-VP-IG
	
Supplies	
Filling washer WIT-SHB and reducing adapter for filling gap between anchor rod and fixture	
	<p>Thickness of filling washer for diameter</p> <p>M8 to M20: t = 5 mm</p> <p>M24: t = 6 mm</p> 
Cleaning supplies	
<p>M8 – M24</p> <p>Vacuum drill bit</p> 	<p>Vacuum drill bit (Würth extraction drill bit, MKT Hollow drill bit SB or Heller Duster Expert) and a class M vacuum cleaner with minimum negative pressure of 253 hPa and a flow rate of minimum 42 l/s</p>
or	
<p>M8 – M24</p> <p>Compressed air tool (min 6 bar)</p> 	<p>Cleaning Brush WIT-RMB</p> 
<p>M8 – M20</p> <p>Blow-out pump (volume 750 ml)</p> 	
Chemical Anchor W-VPZ	
Product description Resin Anchor Capsule, anchor rods and supplies	
Annex A2	

Anchor rod W-VD-A

M8, M10, M12, M16, M20, M24

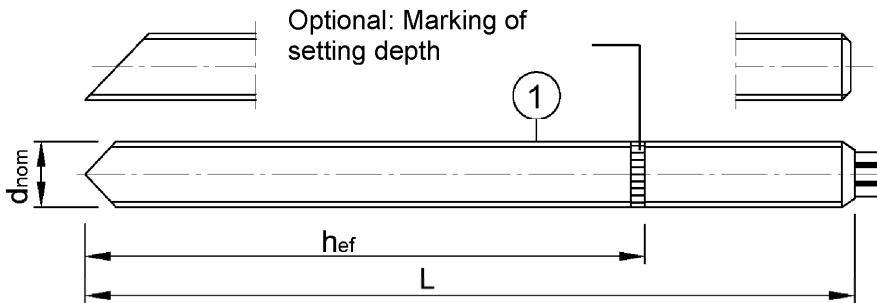

Marking: e.g.: \diamond M10

\diamond identifying mark of manufacturing plant

M10 anchor size

additional marking:

-8 property class 8.8

A4 stainless steel

HC high corrosion resistant steel

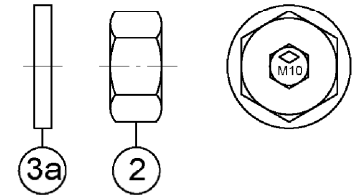

Anchor rod W-VD-A		M8	M10	M12	M16	M20	M24
Outer diameter	$d=d_{nom}$ [mm]	8	10	12	16	20	24
Length	$L \geq$ [mm]	90	101	125	145	192	235
Effective anchorage depth	h_{ef} [mm]	80	90	110	125	170	210
Hexagon nut	wrench size [mm]	13	17	19	24	30	36

Internally threaded anchor rod W-VP-IG

IG M6, IG M8, IG M10, IG M12, IG M16

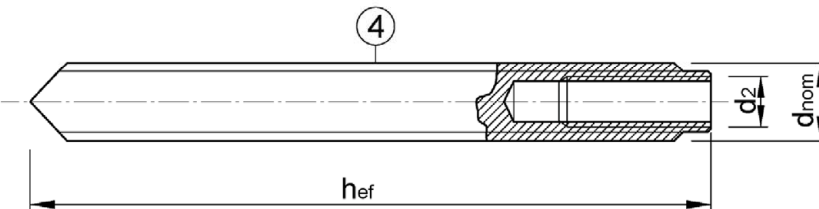

Marking e.g.: \diamond M8

\diamond identifying mark of manufacturing plant

M8 size of internal thread

additional marking:

-8 property class 8.8

A4 stainless steel

HCR high corrosion resistant steel

Internally threaded anchor rod W-VP-IG		IG-M 6	IG-M 8	IG-M 10	IG-M 12	IG-M 16
Outer diameter of threaded rod ¹⁾	$d=d_{nom}$ [mm]	10	12	16	20	24
Inner diameter of threaded rod	d_2 [mm]	6	8	10	12	16
Minimum screw in-depth	l_{IG} [mm]	8	8	10	12	16
Effective anchorage depth	h_{ef} [mm]	90	110	125	170	210

¹⁾ With metric thread acc. to EN 1993-1-8:2005+AC:2009

Requirements for screws or threaded rods (incl. nut and washer):

These must at least correspond to the material and strength class of the internally threaded anchor rod used.

Material:

- **Steel, zinc plated:** Minimum property class 5.8 or 8.8 according to EN ISO 898-1:2013 or EN ISO 898-2:2022
- **Stainless steel A4 or high corrosion resistant steel (HCR):** Minimum property class 70 according to EN ISO 3506-1:2020 oder EN ISO 3506-2:2020

Chemical Anchor W-VPZ

Product description
Marking

Annex A3

Table A1: Materials

Part	Designation	Materials					
Steel, zinc plated							
electroplated $\geq 5 \mu\text{m}$							
hot-dip galvanized $\geq 50 \mu\text{m}$ (average coating thickness)							
sherardized $\geq 45 \mu\text{m}$							
1	Anchor rod	Property class	characteristic ultimate strength		characteristic yield strength		fracture elongation
		5.8	f_{uk} [N/mm ²]	500	f_{yk} [N/mm ²]	400	
		8.8		800		640	$A_5 > 12 \%$
2	Hexagon nut	5	for class 5.8 anchor rods				
		8	for class 5.8, 8.8 anchor rods				
3a	Washer	steel, zinc plated					
3b	Filling washer	steel, zinc plated					
4	Internally threaded anchor rod	5.8	steel, electroplated or sherardized			$A_5 > 8 \%$	
		8.8				$A_5 > 8 \%$	
Stainless steel A4 CRC III acc. to EN 1993-1-4:2006+A1:2015							
High corrosion resistant steel HCR CRC V acc. to EN 1993-1-4:2006+A1:2015							
acc. to EN 10088:2014							
1	Anchor rod	Property class	characteristic ultimate strength		characteristic steel yield strength		fracture elongation
		70	f_{uk} [N/mm ²]	700	f_{yk} [N/mm ²]	560	
		80		800		600	$A_5 > 12 \%$
2	Hexagon nut	70	for class 70 anchor rods				
		80	for class 70, 80 anchor rods				
3a	Washer	stainless steel A4; high corrosion resistant steel HCR					
3b	Filling washer	stainless steel A4; high corrosion resistant steel HCR					
4	Internally threaded anchor rod	70	stainless steel A4; high corrosion resistant steel HCR			$A_5 > 8 \%$	
Glass capsule							
5	Resin Anchor Capsule	glass, quartz, resin, hardener					

Chemical Anchor W-VPZ

Product description
Material

Annex A4

Specifications of intended use

Chemical Anchor W-VPZ with	Anchor rod W-VD-A	Internally threaded anchor rod W-VP-IG
Static or quasi-static action	M8 to M24	IG-M6 to IG-M16
Seismic action, performance category C1	M8 to M24	no performance assessed
Base materials	compacted, reinforced or unreinforced normal weight concrete without fibers acc. to EN 206:2013+A1:2016	
	strength classes C20/25 to C50/60, acc. to EN 206:2013+A1:2016	
	cracked or uncracked concrete	
Temperature range I -40°C to +40°C	max long-term temperature +24°C; max short-term temperature +40°C	
Temperature range II -40°C to +80°C	max long-term temperature +50°C; max short-term temperature +80°C	

Use conditions (Environmental conditions):

- Structures subject to dry internal conditions: all versions
- For all other conditions corresponding to corrosion resistance classes CRC according to EN 1993-1-4:2015, Annex A, Table A1:
 - W-VD-A/A4: CRC III
 - W-VD-A/HCR: CRC V

Design:

- Verifiable calculation notes and drawings are prepared taking account of the loads to be anchored. The position of the anchor is indicated on the design drawings (e.g. position of the anchor relative to reinforcement or to supports, etc.)
- Anchorage are designed under the responsibility of an engineer experienced in anchorages and concrete work
- Anchorage are designed according to EN 1992-4:2018 or TR 055, version February 2018

Installation:

- Dry or wet concrete
- Making of drill hole by hammer drilling, compressed air drilling or vacuum drilling
- Installation direction: D3 - downwards, horizontally and upwards (e.g. overhead) installation
- Optionally, the annular gap between anchor rod and attachment can be backfilled. In this case, the washer is replaced by the filling washer (Part 3b, Annex A2). Würth injection mortars WIT-UH 300, WIT-VM 250, WIT-VIZ, WIT-VIZ EXPRESS or other high-strength injection mortars with a compressive strength $\geq 40\text{N/mm}^2$ can be used for backfilling.
- Internally threaded anchor rods: Bolts or threaded rod (incl. nut and washer) must at least correspond to the material and strength class of the internally threaded anchor rod that is used.

Chemical Anchor W-VPZ

Intended Use
Specifications

Annex B1

Table B1: Installation parameters for anchor rods W-VD-A

Anchor rod W-VD-A		M8	M10	M12	M16	M20	M24
Resin Anchor Capsule		W-VPZ 8	W-VPZ 10	W-VPZ 12	W-VPZ 16	W-VPZ 20	W-VPZ 24
Diameter of threaded rod	$d=d_{nom}$ [mm]	8	10	12	16	20	24
Nominal diameter of drill hole	d_0 [mm]	10	12	14	18	22	28
Depth of drill hole	h_0 [mm]	80	90	110	125	170	210
Effective anchorage depth	h_{ef} [mm]	80	90	110	125	170	210
Diameter of clearance hole in the fixture	d_f [mm]	9	12	14	18	22	26
Cleaning Brush WIT-	[-]	RMB 10	RMB 12	RMB 14	RMB 18	RMB 22	RMB 28
Diameter of Cleaning Brush	$d_b \geq$ [mm]	10,5	12,5	14,5	18,5	22,5	28,5
Maximum installation torque	$\max T_{inst}$ [Nm]	10	20	40	80	150	200
Minimum member thickness	h_{min} [mm]	110	120	140	160	220	270
Minimum edge distance	c_{min} [mm]	40	45	45	50	55	60
Minimum spacing	s_{min} [mm]	40	50	60	75	90	115

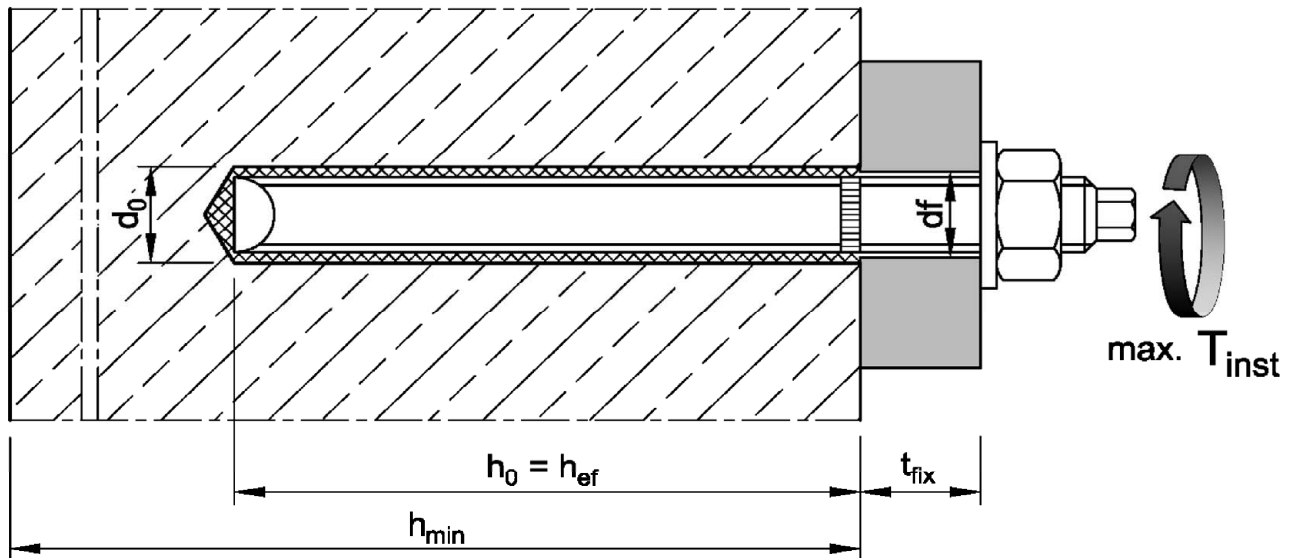

Chemical Anchor W-VPZ

Intended Use
Installation parameters – Anchor rod W-VD-A

Annex B2

Table B2: Installation parameters for internally threaded anchor rods W-VP-IG

Internally threaded anchor rod W-VP-IG			IG-M 6	IG-M 8	IG-M 10	IG-M 12	IG-M 16
Resin Anchor Capsule			W-VPZ 10	W-VPZ 12	W-VPZ 16	W-VPZ 20	W-VPZ 24
Outer diameter of threaded rod ¹⁾	$d=d_{nom}$	[mm]	10	12	16	20	24
Inner diameter of threaded rod	d_2	[mm]	6	8	10	12	16
Nominal drill hole diameter	d_0	[mm]	12	14	18	22	28
Depth of drill hole	h_0	[mm]	90	110	125	170	210
Effective anchorage depth	h_{ef}	[mm]	90	110	125	170	210
Diameter of clearance hole in the fixture	d_f	[mm]	7	9	12	14	18
Cleaning Brush WIT-		[-]	RMB 12	RMB 14	RMB 18	RMB 22	RMB 28
Diameter of Cleaning Brush	$d_b \geq$	[mm]	12,5	14,5	18,5	22,5	28,5
Maximum installation torque	$\max T_{inst}$	[Nm]	10	10	20	40	60
Minimum member thickness	h_{min}	[mm]	120	140	160	220	270
Minimum edge distance	c_{min}	[mm]	45	45	50	55	60
Minimum spacing	s_{min}	[mm]	50	60	75	90	115

¹⁾ With metric thread acc. to EN 1993-1-8:2005+AC:2009

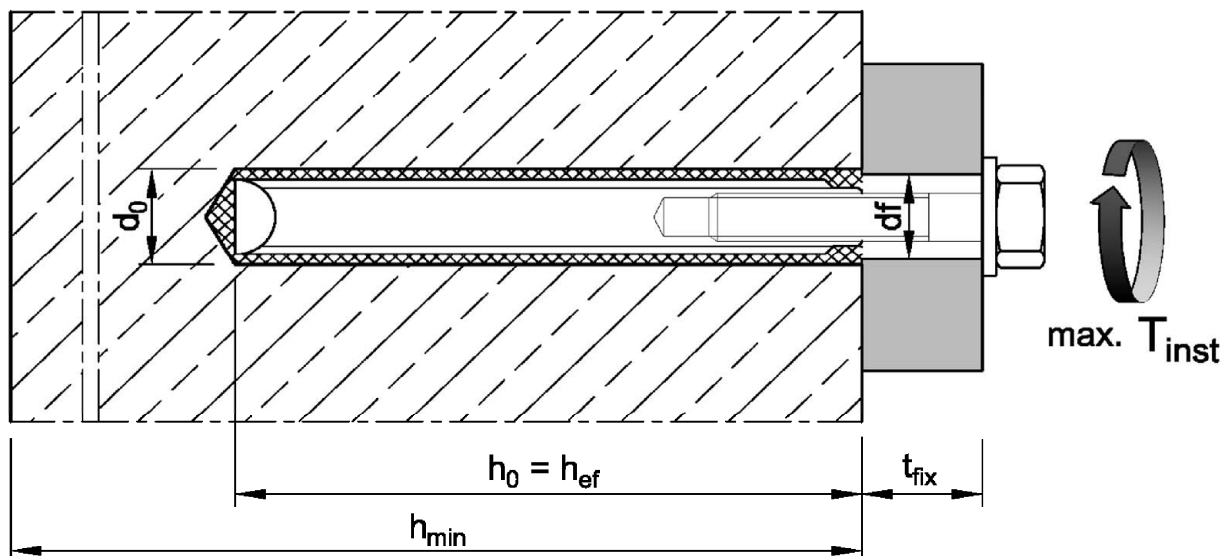

Chemical Anchor W-VPZ

Intended Use
Installation parameters – Internally threaded anchor rod W-VP-IG

Annex B3

Table B3: Curing time

Concrete temperature	Minimum curing time
-20°C to -16°C	17 h
-15°C to -11°C	7 h
-10°C to -6°C	4 h
-5°C to -1°C	3 h
0°C to +4°C	50 min
+5°C to +9°C	25 min
+10°C to +19°C	15 min
+20°C to +29°C	6 min
+30°C to +40°C	6 min
Capsule temperature	-15°C to +40°C

Installation instructions

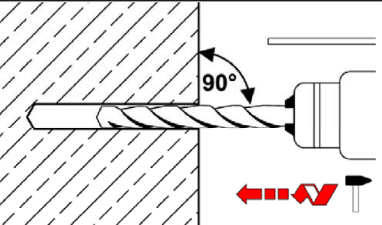
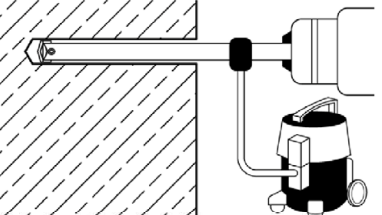
Drilling	
1	 <p>Hammer drill or compressed air drill: Drill the hole with diameter and depth according to Table B1 and B2. Continue with <u>step 2</u>.</p>
	 <p>Vacuum drill: see Annex A2 Drill the hole with diameter and depth according to Table B1 and B2. Additional cleaning is not necessary - continue with <u>step 3</u>.</p>

Chemical Anchor W-VPZ

Intended Use
Curing time / Installation instruction - drilling

Annex B4

Installation instructions – continuation

Cleaning - Drill hole must be cleaned directly before installation of the anchor, or it must be protected against recontamination in a suitable manner until installation of the anchor.

Cleaning with compressed air

Sizes M8 to M24

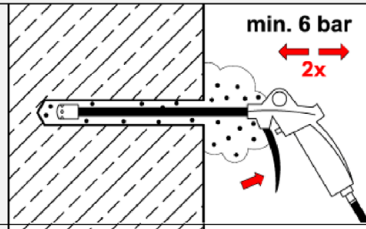
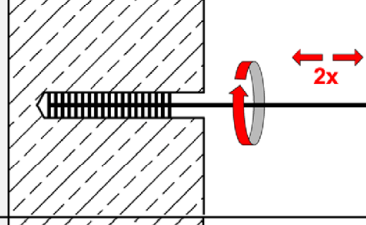
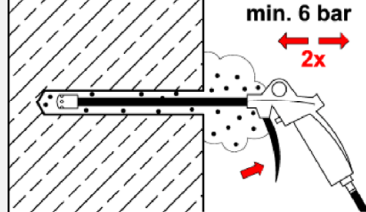
2a		<p>Blow out the drill hole completely at least 2x from the bottom of the drill hole with compressed air.</p>
2b		<p>Brush the drill hole 2x with Cleaning Brush WIT-RMB (Table B1 or B2). Observe and check brush diameter $d_{b,min}$. When inserting the brush into the drill hole, a clear resistance must be noticeable. Otherwise use a new Cleaning Brush.</p>
2c		<p>Blow out the drill hole completely at least 2x from the bottom of the drill hole with compressed air.</p>

2

Manual cleaning

Sizes M8 to M20

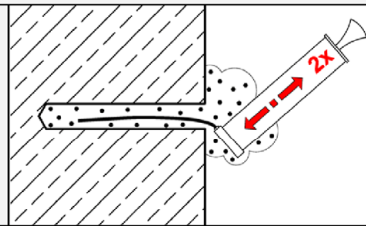
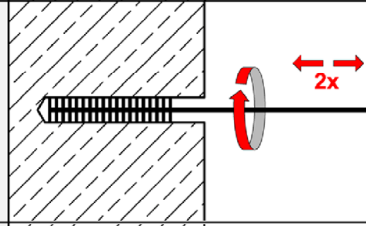
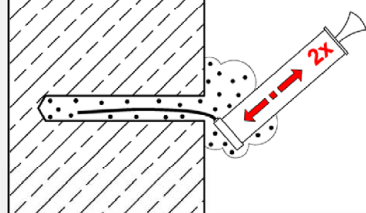
2a		<p>Blow out the drill hole completely at least 2x from the bottom of the drill hole with blow-out pump.</p>
2b		<p>Brush the drill hole 2x with Cleaning Brush WIT-RMB (Table B1 or B2). Observe and check brush diameter $d_{b,min}$. When inserting the brush into the drill hole, a clear resistance must be noticeable. Otherwise use a new Cleaning Brush.</p>
2c		<p>Blow out the drill hole completely at least 2x from the bottom of the drill hole with blow-out pump.</p>

Chemical Anchor W-VPZ

Intended Use
Installation instructions - Cleaning

Annex B5

Installation instructions - continuation

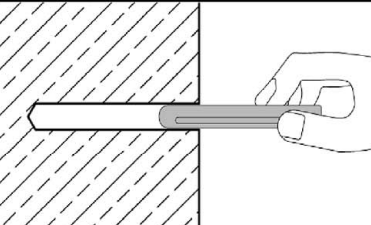
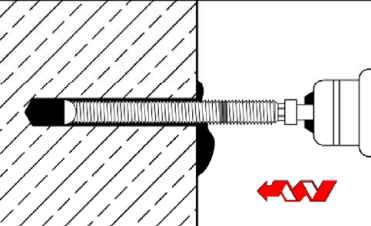
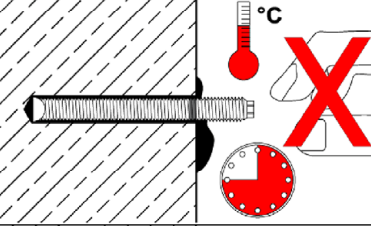
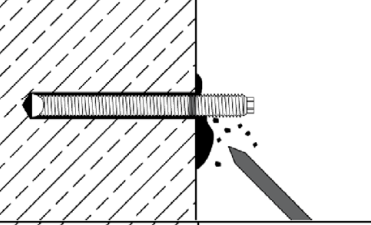
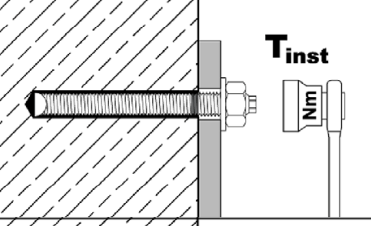
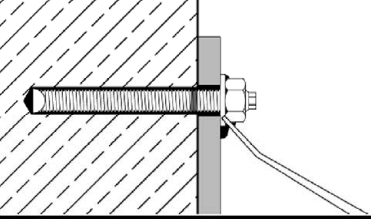
Inserting the anchor rod W-VD-A		
3		<p>Check the depth of drill hole. If necessary, mark anchoring depth on the anchor rods.</p> <p>Insert the capsule into the drill hole.</p>
4		<p>Drive in the anchor rod using a hammer drill set on rotary impact. Stop immediately after reaching the setting depth.</p>
5		<p>Observe curing time according to Table B3. Do not move or load the anchor until it is fully cured.</p>
6		<p>Remove excess adhesive.</p>
7		<p>Install fixture and apply installation torque T_{inst} according to Table B1.</p>
8		<p>The annular gap between anchor rod and fixture may optionally be filled with mortar (see Annex B1). Therefore, replace regular washer by filling washer (note thickness of the filling washer) and plug on reducing adapter on static mixer.</p> <p>Annular gap is completely filled, when excess mortar seeps out.</p>

Chemical Anchor W-VPZ

Intended Use
Installation instructions – Inserting anchor rod W-VD-A

Annex B6

Installation instructions - continuation

Inserting the internally threaded anchor rod W-VP-IG		
3		<p>Check the depth of drill hole.</p> <p>Insert the capsule into the drill hole.</p>
4		<p>Screw the setting tool into the internally threaded anchor rod W-VP-IG until stop. Drive in the internally threaded anchor rod with a hammer drill set to rotary impact. Switch off the hammer drill immediately after reaching the setting depth.</p>
5		<p>Observe curing time according to Table B3. Do not move or load the anchor and don't remove the setting tool until it is fully cured.</p>
6		<p>Remove excess adhesive and unscrew the setting tool.</p>
7		<p>The fixture can be mounted with threaded rod, nut and washer or screw. Apply the installation torque T_{inst} according to Table B2.</p>
8		<p>The annular gap between threaded rod or screw and fixture may optionally be filled with mortar (see Annex B1). Therefore, replace regular washer by filling washer or assemble it on the screw (observe thickness of filling washer and minimum screw-in depth). Plug on reducing adapter on static mixer and fill annular gap. It is completely filled, when excess mortar seeps out.</p>

Chemical Anchor W-VPZ

Intended Use

Installation instructions – Inserting internally threaded anchor rod W-VP-IG

Annex B7

Table C1: Characteristic steel resistance under tension load for anchor rods W-VD-A

Anchor rod W-VD-A				M8	M10	M12	M16	M20	M24
Steel failure									
Characteristic resistance under tension load									
Steel, zinc plated	Property class 5.8	$N_{Rk,s}$	[kN]	18	29	42	79	123	176
	Property class 8.8	$N_{Rk,s}$	[kN]	29	46	67	126	196	282
Stainless steel / High corrosion resistant steel	Property class 70	$N_{Rk,s}$	[kN]	26	41	59	110	172	247
	Property class 80	$N_{Rk,s}$	[kN]	29	46	67	126	196	282
Partial factor ¹⁾									
Steel, zinc plated	Property class 5.8	$\gamma_{Ms,N}$	[-]	1,5					
	Property class 8.8	$\gamma_{Ms,N}$	[-]	1,5					
Stainless steel / High corrosion resistant steel	Property class 70	$\gamma_{Ms,N}$	[-]	1,5					
	Property class 80	$\gamma_{Ms,N}$	[-]	1,6					

¹⁾ In absence of other national regulations

Table C2: Characteristic steel resistance under shear load for anchor rods W-VD-A

Anchor rod W-VD-A				M8	M10	M12	M16	M20	M24
Characteristic resistances under shear load									
Steel failure <u>without</u> lever arm									
Steel, zinc plated	Property class 5.8	$V^0_{Rk,s}$	[kN]	11	17	25	47	73	106
	Property class 8.8	$V^0_{Rk,s}$	[kN]	15	23	34	63	98	141
Stainless steel / High corrosion resistant steel	Property class 70	$V^0_{Rk,s}$	[kN]	13	20	30	55	86	123
	Property class 80	$V^0_{Rk,s}$	[kN]	15	23	34	63	98	141
Steel failure <u>with</u> lever arm									
Steel, zinc plated	Property class 5.8	$M^0_{Rk,s}$	[Nm]	19	37	65	166	325	561
	Property class 8.8	$M^0_{Rk,s}$	[Nm]	30	60	105	266	519	898
Stainless steel / High corrosion resistant steel	Property class 70	$M^0_{Rk,s}$	[Nm]	26	52	92	233	454	785
	Property class 80	$M^0_{Rk,s}$	[Nm]	30	60	105	266	519	898
Partial factor ¹⁾									
Steel, zinc plated	Property class 5.8	$\gamma_{Ms,V}$	[-]	1,25					
	Property class 8.8	$\gamma_{Ms,V}$	[-]	1,25					
Stainless steel / High corrosion resistant steel	Property class 70	$\gamma_{Ms,V}$	[-]	1,25					
	Property class 80	$\gamma_{Ms,V}$	[-]	1,33					

¹⁾ In absence of other national regulations

Chemical Anchor W-VPZ

Performance

Characteristic **steel resistance** under **tension** and **shear load** for **anchor rods W-VD-A**

Annex C1

Table C3: Characteristic values of tension loads for anchor rods W-VD-A

Anchor rod W-VD-A			M8	M10	M12	M16	M20	M24	
Steel failure									
Characteristic resistance under tension load									
Characteristic tension resistance	$N_{Rk,s}$	[kN]	see Table C1						
Partial factor	$\gamma_{Ms,N}$	[-]	see Table C1						
Combined pull-out and concrete failure									
Characteristic bond resistance in <u>uncracked</u> concrete C20/25									
Temperature range I:	+24°C / +40°C	$\tau_{Rk,ucr}$	[N/mm ²]	10,0	13,0	13,0	13,0	13,0	13,0
Temperature range II:	+50°C / +80°C	$\tau_{Rk,ucr}$	[N/mm ²]	8,5	11,0	11,0	11,0	11,0	11,0
Increasing factors for $\tau_{Rk,ucr}$ $\tau_{Rk,ucr} = \psi_{c,ucr} \cdot \tau_{Rk,ucr}(C20/25)$	$\psi_{c,ucr}$	[-]	$\left(\frac{f_{ck}}{20}\right)^{0,17}$						
Characteristic bond resistance in <u>cracked</u> concrete C20/25									
Temperature range I:	+24°C / +40°C	$\tau_{Rk,cr}$	[N/mm ²]	5,0	6,5	7,0	7,5	7,5	7,5
Temperature range II:	+50°C / +80°C	$\tau_{Rk,cr}$	[N/mm ²]	4,5	5,5	6,0	6,0	6,0	6,5
Increasing factors for $\tau_{Rk,cr}$ $\tau_{Rk,cr} = \psi_{c,cr} \cdot \tau_{Rk,cr}(C20/25)$	$\psi_{c,cr}$	[-]	$\left(\frac{f_{ck}}{20}\right)^{0,14}$						
Reduction factor ψ^0_{sus} in concrete C20/25									
Temperature range I:	+24°C / +40°C	ψ^0_{sus}	[-]	0,64					
Temperature range II:	+50°C / +80°C	ψ^0_{sus}	[-]	0,63					
Concrete cone failure									
Factor for	uncracked concrete	$k_{ucr,N}$	[-]	11,0					
	cracked concrete	$k_{cr,N}$	[-]	7,7					
Edge distance		$c_{cr,N}$	[mm]	1,5 h_{ef}					
Spacing		$s_{cr,N}$	[mm]	3 h_{ef}					
Splitting failure									
Edge distance	$h/h_{ef} \geq 2,0$	$c_{cr,sp}$	[mm]	1,0 h_{ef}					
	$2,0 > h/h_{ef} > 1,3$			$2 \cdot h_{ef} (2,5 - h / h_{ef})$					
	$h/h_{ef} \leq 1,3$			2,4 h_{ef}					
Spacing		$s_{cr,sp}$	[mm]	2 $c_{cr,sp}$					
Installation factor		γ_{inst}	[-]	1,2					

Chemical Anchor W-VPZ

Performance
Characteristic values under **tension load** for **anchor rods W-VD-A**

Annex C2

Table C4: Characteristic values of shear loads for anchor rods W-VD-A

Anchor rod W-VD-A			M8	M10	M12	M16	M20	M24
Steel failure <u>without</u> lever arm								
Characteristic resistance	$V_{Rk,s}^0$	[kN]	see Table C2					
Ductility factor	k_7	[-]	1,0					
Partial factor	$\gamma_{Ms,V}$	[-]	see Table C2					
Steel failure <u>with</u> lever arm								
Characteristic bending resistance	$M_{Rk,s}^0$	[Nm]	see Table C2					
Partial factor	$\gamma_{Ms,V}$	[-]	see Table C2					
Concrete pry-out failure								
Pry-out factor	k_8	[-]	2,0					
Concrete edge failure								
Effective length of anchor	l_f	[mm]	80	90	110	125	170	210
Outside diameter of anchor	d_{nom}	[mm]	8	10	12	16	20	24
Installation factor	γ_{inst}	[-]	1,0					

Chemical Anchor W-VPZ

Performance

Characteristic values under **shear load** for anchor rods W-VD-A

Annex C3

Table C5: Characteristic values of tension loads for anchor rods W-VD-A under seismic action, performance category C1

Anchor rod W-VD-A			M8	M10	M12	M16	M20	M24	
Steel failure									
Characteristic resistance under tension load									
Characteristic tension resistance	$N_{RK,s,C1}$	[kN]	$N_{RK,s}$ see Table C1						
Partial factor	$\gamma_{Ms,N}$	[-]	see Table C1						
Combined pull-out and concrete failure									
Characteristic bond resistance in concrete C20/25 to C50/60									
Temperature range I:	+24°C / +40°C	$\tau_{RK,C1}$	[N/mm ²]	4,5	5,5	6,0	6,0	7,5	7,0
Temperature range II:	+50°C / +80°C	$\tau_{RK,C1}$	[N/mm ²]	4,0	4,5	5,5	5,0	6,0	5,5
Installation factor	γ_{inst}	[-]	1,2						

Table C6: Characteristic values of shear loads for anchor rods W-VD-A under seismic action, performance category C1

Anchor rod W-VD-A			M8	M10	M12	M16	M20	M24	
Steel failure without lever arm									
Characteristic resistance under shear load									
Steel, zinc plated	Property class 5.8	$V_{RK,s,C1}$	[kN]	9,0	14,3	20,7	36,3	56,2	81,5
	Property class 8.8	$V_{RK,s,C1}$	[kN]	12,0	19,0	27,7	48,4	75,5	109,3
Stainless steel / High corrosion resistant steel	Property class 70	$V_{RK,s,C1}$	[kN]	10,5	16,6	24,2	42,3	66,0	94,7
	Property class 80	$V_{RK,s,C1}$	[kN]	12,0	19,0	27,7	48,4	75,5	108,7
Partial factor	$\gamma_{Ms,V}$	[-]	see Table C2						
Factor for anchorages	with annular gap	α_{gap}	[-]	0,5					
	without annular gap	α_{gap}	[-]	1,0					
Installation factor	γ_{inst}	[-]	1,0						

Chemical Anchor W-VPZ

Performance

Characteristic values under seismic action, performance category C1 for anchor rods W-VD-A

Annex C4

Table C7: Characteristic steel resistance under tension load for internally threaded anchor rods W-VP-IG

Internally threaded anchor rod				IG-M 6	IG-M 8	IG-M 10	IG-M 12	IG-M 16
Steel failure								
Characteristic resistance, steel, zinc plated	Property class 5.8	$N_{Rk,s}$	[kN]	10	17	29	42	76
	Property class 8.8	$N_{Rk,s}$	[kN]	16	27	46	67	121
Partial factor ¹⁾		$\gamma_{Ms,N}$	[-]	1,5				
Characteristic resistance, stainless steel A4 / HCR	Property class 70	$N_{Rk,s}$	[kN]	14	26	41	59	110
				Partial factor ¹⁾				
Combined pull-out and concrete failure								
Characteristic bond resistance in <u>uncracked</u> concrete C20/25								
Temperature range I:	+24°C / +40°C	$\tau_{Rk,ucr}$	[N/mm ²]	13,0	13,0	13,0	13,0	13,0
Temperature range II:	+50°C / +80°C	$\tau_{Rk,ucr}$	[N/mm ²]	11,0	11,0	11,0	11,0	11,0
Increasing factors for $\tau_{Rk,ucr}$ $\tau_{Rk,ucr} = \psi_{c,ucr} \cdot \tau_{Rk,ucr}$ (C20/25)		$\psi_{c,ucr}$	[-]	$\left(\frac{f_{ck}}{20}\right)^{0,17}$				
Characteristic bond resistance in <u>cracked</u> concrete C20/25								
Temperature range I:	+24°C / +40°C	$\tau_{Rk,cr}$	[N/mm ²]	6,5	7,0	7,5	7,5	7,5
Temperature range II:	+50°C / +80°C	$\tau_{Rk,cr}$	[N/mm ²]	5,5	6,0	6,0	6,0	6,5
Increasing factors for $\tau_{Rk,cr}$ $\tau_{Rk,cr} = \psi_{c,cr} \cdot \tau_{Rk,cr}$ (C20/25)		$\psi_{c,cr}$	[-]	$\left(\frac{f_{ck}}{20}\right)^{0,14}$				
Reduction factor ψ^0_{sus} in concrete C20/25								
Temperature range I:	+24°C / +40°C	ψ^0_{sus}	[-]	0,64				
Temperature range II:	+50°C / +80°C	ψ^0_{sus}	[-]	0,63				
Concrete cone failure								
Factor for	uncracked concrete	$k_{ucr,N}$	[-]	11,0				
	cracked concrete	$k_{cr,N}$	[-]	7,7				
Edge distance		$c_{cr,N}$	[mm]	1,5 h_{ef}				
Spacing		$s_{cr,N}$	[mm]	3 h_{ef}				
Splitting failure								
Edge distance	$h/h_{ef} \geq 2,0$	$c_{cr,sp}$	[mm]	1,0 h_{ef}				
	$2,0 > h/h_{ef} > 1,3$			$2 \cdot h_{ef} (2,5 - h / h_{ef})$				
	$h/h_{ef} \leq 1,3$			2,4 h_{ef}				
Spacing		$s_{cr,sp}$	[mm]	2 $c_{cr,sp}$				
Installation factor		γ_{inst}	[-]	1,2				

¹⁾ In absence of other national regulations

Chemical Anchor W-VPZ

Performance
Characteristic values under tension load for internally threaded anchor rods W-VP-IG

Annex C5

Table C8: Characteristic steel resistance under shear load for internally threaded anchor rods W-VP-IG

Internally threaded anchor rod				IG-M 6	IG-M 8	IG-M 10	IG-M 12	IG-M 16
Steel failure <u>without</u> lever arm ¹⁾								
Steel, zinc plated	Property class 5.8	$V_{RK,s}^0$	[kN]	6	10	17	25	45
	Property class 8.8	$V_{RK,s}^0$	[kN]	8	14	23	34	60
Stainless steel A4 / HCR	Property class 70	$V_{RK,s}^0$	[kN]	7	13	20	30	55
Ductility factor		k_7	[-]	1,0				
Steel failure <u>with</u> lever arm ¹⁾								
Steel, zinc plated	Property class 5.8	$M_{RK,s}^0$	[Nm]	8	19	37	66	167
	Property class 8.8	$M_{RK,s}^0$	[Nm]	12	30	60	105	267
Stainless steel A4 / HCR	Property class 70	$M_{RK,s}^0$	[Nm]	11	26	53	92	234
Partial factor ²⁾								
Steel, zinc plated	Property class 5.8	$\gamma_{Ms,V}$	[-]	1,25				
	Property class 8.8	$\gamma_{Ms,V}$	[-]	1,25				
Stainless steel A4 / HCR	Property class 70	$\gamma_{Ms,V}$	[-]	1,56				
Concrete pry-out failure								
Pry-out factor		k_8	[-]	2,0				
Concrete edge failure								
Effective length of fastener		l_f	[mm]	90	110	125	170	210
Outside diameter of fastener		d_{nom}	[mm]	10	12	16	20	24
Installation factor		γ_{inst}	[-]	1,0				

¹⁾ Fastening screws or threaded rods (incl. nut and washer) must comply with the appropriate material and property class of the internally threaded anchor rod. The characteristic shear resistance for steel failure of the given strength class are valid for the internally threaded anchor rod and the fastening element

²⁾ In absence of other national regulations

Chemical Anchor W-VPZ

Performance

Characteristic values under **shear load** for **internally threaded anchor rods W-VP-IG**

Annex C6

Table C9: Displacements under tension load

Anchor size			M8	M10 IG-M6	M12 IG-M8	M16 IG-M10	M20 IG-M12	M24 IG-M16
Displacement factor¹⁾ for uncracked concrete								
Displacement	δ_{N0} -factor	[mm/(N/mm ²)]	0,015	0,031	0,035	0,015	0,046	0,060
	$\delta_{N\infty}$ -factor	[mm/(N/mm ²)]	0,085	0,067	0,067	0,067	0,067	0,067
Displacement factor¹⁾ for cracked concrete								
Displacement	δ_{N0} -factor	[mm/(N/mm ²)]	0,046	0,038	0,024	0,008	0,024	0,133
	$\delta_{N\infty}$ -factor	[mm/(N/mm ²)]	0,192	0,142	0,090	0,104	0,082	0,069

¹⁾ Calculation of the displacement

$$\delta_{N0} = \delta_{N0}\text{-factor} \cdot \tau; \quad \tau: \text{acting bond stress for tension}$$

$$\delta_{N\infty} = \delta_{N\infty}\text{-factor} \cdot \tau;$$

Table C10: Displacements under shear load

Anchor size			M8	M10 IG-M6	M12 IG-M8	M16 IG-M10	M20 IG-M12	M24 IG-M16
Displacement factor¹⁾								
Displacement	δ_{V0} -factor	[mm/(kN)]	0,06	0,06	0,05	0,04	0,04	0,03
	$\delta_{V\infty}$ -factor	[mm/(kN)]	0,09	0,08	0,08	0,06	0,06	0,05

¹⁾ Calculation of the displacement

$$\delta_{V0} = \delta_{V0}\text{-factor} \cdot V; \quad V: \text{acting shear load}$$

$$\delta_{V\infty} = \delta_{V\infty}\text{-factor} \cdot V;$$

Chemical Anchor W-VPZ

Performance
Displacements

Annex C7