

Approval body for construction products  
and types of construction

Bautechnisches Prüfamt

An institution established by the Federal and  
Laender Governments



## European Technical Assessment

ETA-22/0001  
of 31 July 2023

English translation prepared by DIBt - Original version in German language

### General Part

Technical Assessment Body issuing the  
European Technical Assessment:

Deutsches Institut für Bautechnik

Trade name of the construction product

fischer injection system FIS EM Plus

Product family  
to which the construction product belongs

Post-installed reinforcing bar (rebar) connections with  
improved bond-splitting behaviour under static loading  
and seismic action

Manufacturer

fischerwerke GmbH & Co. KG  
Otto-Hahn-Straße 15  
79211 Denzlingen  
DEUTSCHLAND

Manufacturing plant

fischerwerke

This European Technical Assessment  
contains

20 pages including 3 annexes which form an integral part  
of this assessment

This European Technical Assessment is  
issued in accordance with Regulation (EU)  
No 305/2011, on the basis of

332402-00-0601-v02, Edition 10/2022

This version replaces

ETA-22/0001 issued on 8 June 2022

The European Technical Assessment is issued by the Technical Assessment Body in its official language. Translations of this European Technical Assessment in other languages shall fully correspond to the original issued document and shall be identified as such.

Communication of this European Technical Assessment, including transmission by electronic means, shall be in full. However, partial reproduction may only be made with the written consent of the issuing Technical Assessment Body. Any partial reproduction shall be identified as such.

This European Technical Assessment may be withdrawn by the issuing Technical Assessment Body, in particular pursuant to information by the Commission in accordance with Article 25(3) of Regulation (EU) No 305/2011.

## Specific Part

### 1 Technical description of the product

The subject of this European technical assessment is the post-installed connection, by anchoring or overlap connection joint, of reinforcing bars (rebars) in existing structures made of normal weight concrete, using the fischer injection system FIS EM Plus in accordance with the regulations for reinforced concrete construction.

Reinforcing bars with a diameter  $\phi$  from 8 to 40 mm according to Annex A and the injection mortar FIS EM Plus are used for the post-installed rebar connection. The rebar is placed into a drilled hole filled with injection mortar and is anchored via the bond between embedded reinforcing bar, injection mortar and concrete.

The product description is given in Annex A.

### 2 Specification of the intended use in accordance with the applicable European assessment Document

The performances given in Section 3 are only valid if the rebar connection is used in compliance with the specifications and conditions given in Annex B.

The verifications and assessment methods on which this European Technical Assessment is based lead to the assumption of a working life of the rebar connections of at least 50 and/or 100 years. The indications given on the working life cannot be interpreted as a guarantee given by the producer, but are to be regarded only as a means for choosing the right products in relation to the expected economically reasonable working life of the works.

### 3 Performance of the product and references to the methods used for its assessment

#### 3.1 Mechanical resistance and stability (BWR 1)

Essential characteristic	Performance
Characteristic resistance to tension load (static and quasi-static loading)	See Annex C 1 to C 3
Characteristic resistance to tension load (seismic loading)	See Annex C 4

#### 3.2 Safety in case of fire (BWR 2)

Essential characteristic	Performance
Reaction to fire	Class A1

**4 Assessment and verification of constancy of performance (AVCP) system applied, with reference to its legal base**

In accordance with European Assessment Document EAD No. 332402-00-0601-v02, the applicable European legal act is: [96/582/EC].

The system to be applied is: 1

**5 Technical details necessary for the implementation of the AVCP system, as provided for in the applicable European Assessment Document**

Technical details necessary for the implementation of the AVCP system are laid down in the control plan deposited with Deutsches Institut für Bautechnik.

Issued in Berlin on 31 July 2023 by Deutsches Institut für Bautechnik

Dipl.-Ing. Beatrix Wittstock  
Head of Section

*beglaubigt:*  
Stiller

## Installation conditions and application examples reinforcing bars

**Figure A1.1:**

Column / wall to foundation / slab

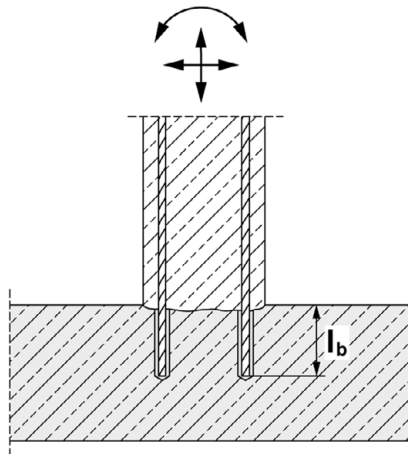

**Figure A1.2:**

Slab / beam to wall or beam to column

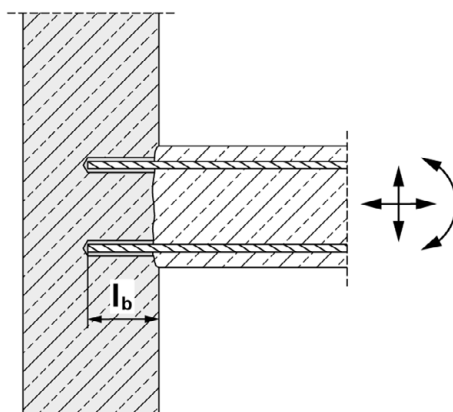

Figures not to scale

**fischer injection system FIS EM Plus**

**Product description**

Installation conditions and application examples reinforcing bars

**Annex A 1**

## Overview system components

**Injection cartridge (shuttle cartridge) FIS EM Plus with sealing cap; Sizes: 390 ml, 585 ml, 1100 ml, 1500 ml**

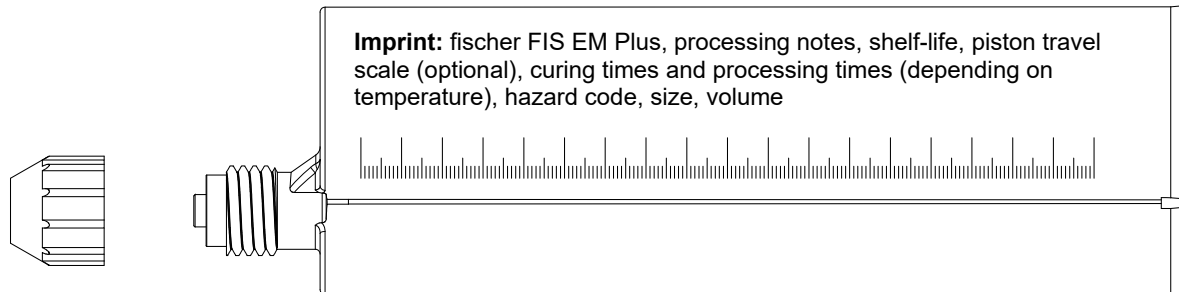

**Static mixer FIS MR Plus for injection cartridges 390 ml**

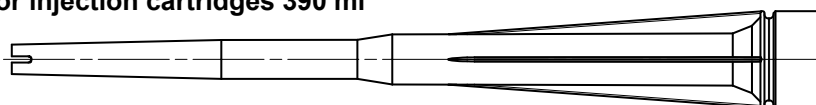

**Static mixer FIS UMR for injection cartridges ≥ 585 ml**

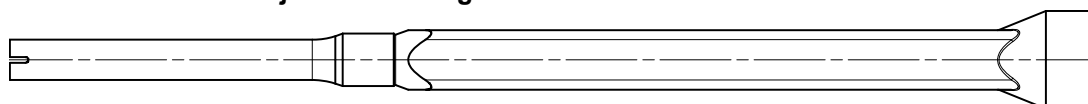

**Injection adapter and extension tube Ø 9 for static mixer FIS MR Plus;  
Injection adapter and extension tube Ø 9 or Ø 15 for static mixer FIS UMR**

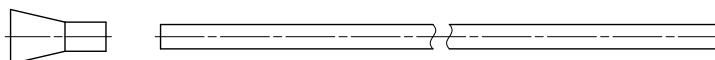

**Reinforcing bar (rebar) Sizes:  $\phi 8$ ,  $\phi 10$ ,  $\phi 12$ ,  $\phi 14$ ,  $\phi 16$ ,  $\phi 20$ ,  $\phi 22$ ,  $\phi 24$ ,  $\phi 25$ ,  $\phi 26$ ,  $\phi 28$ ,  $\phi 30$ ,  $\phi 32$ ,  $\phi 34$ ,  $\phi 36$ ,  $\phi 40$**



**fischer cleaning brush**



**Compressed-air cleaning tool with fischer compressed-air nozzle**

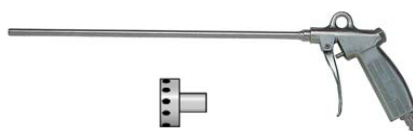

Figures not to scale

**fischer injection system FIS EM Plus**

### Product description

Overview system components: injection mortar, static mixer, injection adapter, reinforcing bar, cleaning tools

**Annex A 2**

## Properties of reinforcing bars (rebar)

Figure A3.1:



- The minimum value of related rib area  $f_{R,min}$  according to EN 1992-1-1:2004+AC:2010
- The maximum outer rebar diameter over the ribs shall be:
  - The nominal diameter of the bar with rib  $\phi + 2 \cdot h_{rib}$  ( $h_{rib} \leq 0,07 \cdot \phi$ )
  - ( $\phi$ : Nominal diameter of the bar;  $h_{rib}$  = rib height of the bar)

**Table A3.1: Installation conditions for rebars**

Nominal diameter of the bar		$\phi$	8 <sup>1)</sup>		10 <sup>1)</sup>		12 <sup>1)</sup>		14	16	20	22	24
Nominal drill hole diameter	$d_0$	[mm]	10	12	12	14	14	16	18	20	25	30	30
Drill hole depth	$h_0$		$h_0 \geq l_b$										
Effective embedment depth	$l_b = l_v$		acc. to static calculation										
Minimum thickness of concrete member	$h_{min}$		$l_b + 30$ ( $\geq 100$ )					$l_b + 2d_0$					

Nominal diameter of the bar		$\phi$	25 <sup>1)</sup>		26	28	30	32	34	36	40	
Nominal drill hole diameter	$d_0$	[mm]	30	35	35	35	40	40	40	45	55	
Drill hole depth	$h_0$		$h_0 \geq l_b$									
Effective embedment depth	$l_b = l_v$		acc. to static calculation									
Minimum thickness of concrete member	$h_{min}$		$l_b + 2d_0$									

<sup>1)</sup> Both drill hole diameters can be used

**Table A3.2: Materials of rebars**

Designation	Reinforcing bar (rebar)
Reinforcing bar EN 1992-1-1:2004+AC:2010, Annex C	Bars and de-coiled rods class B or C with $f_{yk}$ and $k$ according to NDP or NCI of EN 1992-1-1/NA $f_{uk} = f_{tk} = k \cdot f_{yk}$



**fischer injection system FIS EM Plus**

**Product description**  
Properties and materials of reinforcing bars (rebar)

**Annex A 3**

## Specifications of intended use part 1

**Table B1.1:** Overview use and performance categories

Fastenings subject to		FIS EM Plus with ...	
		Reinforcing bar 	
Hammer drilling with standard drill bit 		all sizes	
Hammer drilling with hollow drill bit (fischer "FHD", Heller "Duster Expert"; Bosch "Speed Clean"; Hilti "TE-CD, TE-YD", DreBo „D-Plus“, DreBo „D-Max“) 		Nominal drill bit diameter ( $d_0$ ) 12 mm to 35 mm	
Use category	I1 dry or wet concrete	all sizes	
	I2 water filled hole	all sizes (not permitted in combination with working life 100 years)	
Characteristic resistance under static and quasi-static loading	in uncracked concrete	all sizes	Tables: C1.1 C1.2 C2.1 C3.1
	in cracked concrete	all sizes	
Seismic performance		all sizes	Tables: C4.1
Installation direction		D3 (downward and horizontal and upwards (e.g. overhead))	
Installation temperature		$T_{i,min} = -5\text{ °C}$ to $T_{i,max} = +40\text{ °C}$ for the standard variation of temperature after installation	
Service temperature	Temperature range I	-40 °C to +60 °C	(max. short term temperature +60 °C; max. long term temperature +35 °C)
	Temperature range II	-40 °C to +72 °C	(max. short term temperature +72 °C; max. long term temperature +50 °C)
<b>fischer injection system FIS EM Plus</b>			<b>Annex B 1</b>
<b>Intended use Specifications part 1</b>			



## Specifications of intended use part 2

### Anchorage subject to:

- Static and quasi-static loading: reinforcing bar (rebar) size 8 mm to 40 mm
- Seismic action: reinforcing bar (rebar) size 8 mm to 40 mm

### Base materials:

- Compacted reinforced or unreinforced normal weight concrete without fibres according to EN 206:2013+A1:2016.
- Strength classes C20/25 to C50/60 according to EN 206:2013+A1:2016
- Maximum chloride content of 0,40 % (CL 0.40) related to the cement content according to EN 206:2013+A1:2016
- Non-carbonated concrete

Note: In case of a carbonated surface of the existing concrete structure, the carbonated layer shall be removed in the area of the post-installed rebar connection with a diameter of  $\phi + 60$  mm prior to the installation of the new rebar. The depth of concrete to be removed shall correspond to at least the minimum concrete cover in accordance with EN 1992-1-1 :2004+AC:2010. The foregoing may be neglected if building components are new and not carbonated and if building components are in dry conditions.

### Design:

- Fastenings are designed under the responsibility of an engineer experienced in fastenings and concrete work.
- Verifiable calculation notes and drawings are prepared taking account of the forces to be transmitted.
- Design under static and quasi-static loading and for seismic actions in accordance with EOTA Technical Report TR 069 June 2021.
- The actual position of the reinforcement in the existing structure shall be determined on the basis of the construction documentation and taken into account when designing.
- The shear force must be transferred via the rough joint; the subsequent reinforcement must not be applied for shear force transfer.

### Installation:

- Rebar installation carried out by appropriately qualified personnel and under the supervision of the person responsible for technical matters of the site.
- Check the position of the existing rebars (if the position of existing rebars is not known, it shall be determined using a rebar detector suitable for this purpose as well as on the basis of the construction documentation and then marked on the building component for the overlap joint).
- Rebars in overhead installation have to be fixed in their position until the injection mortar is cured.

**fischer injection system FIS EM Plus**

**Intended use**  
Specifications part 2

**Annex B 2**

**Table B3.1: Minimum concrete cover  $c_{min}$ <sup>1)</sup> depending on the drilling method and the drilling tolerance<sup>2)</sup>**

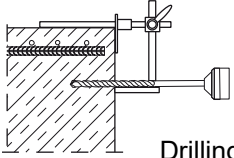
Drilling method	nominal diameter of reinforcing bar $\phi$ [mm]	Minimum concrete cover $c_{min}$		
		Without drilling aid [mm]	With drilling aid [mm]	
Hammer drilling with standard drill bit	< 25	30 mm + 0,06 $l_b \geq 2 \phi$	30 mm + 0,02 $l_b \geq 2 \phi$	
	$\geq 25$	40 mm + 0,06 $l_b \geq 2 \phi$	40 mm + 0,02 $l_b \geq 2 \phi$	
Hammer drilling with hollow drill bit (fischer "FHD", Heller "Duster Expert"; Bosch "Speed Clean"; Hilti "TE-CD, TE-YD")	< 25	30 mm + 0,06 $l_b \geq 2 \phi$	30 mm + 0,02 $l_b \geq 2 \phi$	
	$\geq 25$	40 mm + 0,06 $l_b \geq 2 \phi$	40 mm + 0,02 $l_b \geq 2 \phi$	

<sup>1)</sup> Note: The minimum concrete cover as specified in EN 1992-1-1:2004+AC:2010 must be observed.

<sup>2)</sup> Minimum clear spacing is  $a = \max(40 \text{ mm}; 4 \cdot \phi)$

**Table B3.2: Dispensers and cartridge sizes corresponding to maximum embedment depth  $l_{b,max}$**

reinforcing bars (rebar)	Manual dispenser	Pneumatic or cordless dispenser (small)	Pneumatic or cordless dispenser (large)
	Cartridge size 390 ml, 585 ml	Cartridge size 390 ml, 585 ml	Cartridge size 1500 ml
$\phi$ [mm]	$l_{b,max}$ [mm]	$l_{b,max}$ [mm]	$l_{b,max}$ [mm]
8	1000	1000	1800
10		1200	
12			
14			
16		1500	
20	1300		
22 / 24 / 25	700	1000	2000
26 / 28	500	700	
30 / 32 / 34	no performance assessed	500	
36 / 40			

Figures not to scale



**fischer injection system FIS EM Plus**

**Intended use**

Minimum concrete cover;  
dispenser and cartridge sizes corresponding to maximum embedment depth



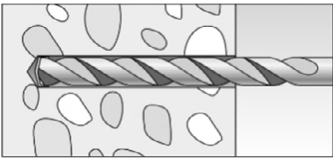

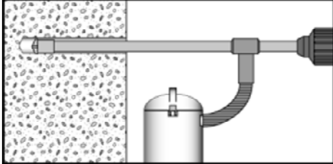
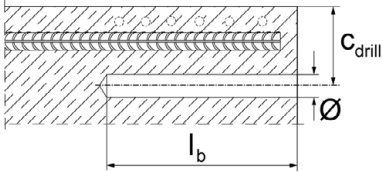
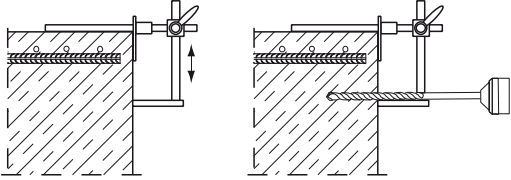
**Annex B 3**

<b>Table B4.1: Conditions for use static mixer without an extension tube</b>															
Nominal drill hole diameter	$d_0$	[mm]	10	12	14	16	18	20	24	25	28	30	35	40	
Drill hole depth $h_0$ by using	FIS MR Plus		$\leq 90$		$\leq 120$	$\leq 140$	$\leq 150$	$\leq 160$	$\leq 190$	$\leq 210$					
	FIS UMR		-	-	$\leq 90$	$\leq 160$	$\leq 180$	$\leq 190$	$\leq 220$		$\leq 250$				
<b>Table B4.2: Working times <math>t_{work}</math> and curing times <math>t_{cure}</math></b>															
Temperature at anchoring base [°C]		Maximum processing time <sup>1)</sup> $t_{work}$				Minimum curing time <sup>2)</sup> $t_{cure}$									
-5 to 0		240 min <sup>3)</sup>				200 h									
>0 to 5		150 min <sup>3)</sup>				90 h									
>5 to 10		120 min <sup>3)</sup>				40 h									
>10 to 20		30 min				18 h									
>20 to 30		14 min				10 h									
>30 to 40		7 min <sup>4)</sup>				5 h									
<sup>1)</sup> Maximum time from the beginning of the injection to the setting and the final positioning of the rebar <sup>2)</sup> For wet concrete the curing time must be doubled <sup>3)</sup> If the temperature in the concrete falls below 10 °C the cartridge must be warmed up to +15 °C. <sup>4)</sup> If the temperature in the concrete exceeds 30 °C the cartridge must be cooled down to +15 °C up to 20 °C															
<b>Table B4.3: Installation tools for drilling and cleaning the bore hole and injection of the mortar</b>															
reinforcing bars (rebar)	Drilling and cleaning				Injection										
	Nominal drill bit diameter $d_0$ [mm]	Diameter of cutting edge $d_{cut}$ [mm]	Steel brush diameter $d_b$ [mm]	Diameter of cleaning nozzle <sup>3)</sup> [mm]	Diameter of extension tube [mm]	Injection adapter [colour]									
$\phi$ [mm]															
8 <sup>1)</sup>	10 <sup>2)</sup>	$\leq 10,50$	11	---	9	---									
	12	$\leq 12,50$	14	11		nature									
10 <sup>1)</sup>	12	$\leq 12,50$	14		15	blue									
	14	$\leq 14,50$	16	red											
12 <sup>1)</sup>	14	$\leq 14,50$	16	19	yellow										
	16	$\leq 16,50$	20		green										
14	18	$\leq 18,50$	20	28	black										
16	20	$\leq 20,55$	25		grey										
20	25	$\leq 25,55$	27	38	grey										
22 / 24	30	$\leq 30,55$	32		grey										
25 <sup>1)</sup>	30	$\leq 30,55$	32	9 or 15	brown										
	35	$\leq 35,70$	37		brown										
26 / 28	35	$\leq 35,70$	37	38	red										
30 / 32 / 34	40 <sup>2)</sup>	$\leq 40,70$	42		yellow										
36	45 <sup>2)</sup>	$\leq 45,70$	47	58	nature										
40	55 <sup>2)</sup>	$\leq 55,70$	58												
<sup>1)</sup> Both drill bit diameters can be used <sup>2)</sup> Only hammer drilling with standard drill bit <sup>3)</sup> Cleaning nozzle and extension is only necessary if bore hole depth is greater than the length of compressed-air cleaning tool															
<b>fischer injection system FIS EM Plus</b>						<b>Annex B 4</b>									
<b>Intended use</b> Conditions for use static mixer without an extension tube; Working times and curing times; Installation tools for drilling and cleaning the bore hole and injection of the mortar															

Safety regulations	
	<p>Review the Safety Data Sheet (SDS) before use for proper and safe handling! Wear well-fitting protective goggles and protective gloves when working with mortar FIS EM Plus. Important: Observe the instructions for use provided with each cartridge.</p>
Installation instruction part 1 Hole drilling	
<p>Note: Before drilling, remove carbonated concrete; clean contact areas (see Annex B 2) In case of aborted drill holes the drill hole shall be filled with mortar.</p>	
<p>1a</p>	<p><b>Hammer drilling with standard drill bit</b></p>  <p>Drill the hole to the required embedment depth using a hammer drill with carbide drill bit set in rotation hammer mode. Nominal drill hole diameter <math>d_0</math> (see <b>table B4.3</b>) and drill hole depth <math>h_0</math> (see <b>table A3.1</b>).</p>
<p>1b</p>	<p><b>Hammer drilling with hollow drill bit</b></p>  <p>Check a suitable hollow drill (see <b>table B1.1</b>) for correct operation of the dust extraction.</p>
	 <p>Drill the hole to the required embedment depth using a hammer drill with hollow drill bit in rotation hammer mode. Dust extraction conditions see drill hole cleaning <b>Annex B 6</b>. Nominal drill hole diameter <math>d_0</math> (see <b>table B4.3</b>) and drill hole depth <math>h_0</math> (see <b>table A3.1</b>).</p>
<p>2</p>	 <p>Measure and control concrete cover <math>c</math> (<math>c_{\text{drill}} = c + \varnothing / 2</math>) Drill parallel to surface edge and to existing rebar. Where applicable use fischer drilling aid.</p>  <p>For holes <math>l_b &gt; 20</math> cm use drilling aid. Three different options can be considered: A) fischer drilling aid B) Slat or spirit level C) Visual check</p> <p>Minimum concrete cover <math>c_{\text{min}}</math> see <b>table B3.1</b>.</p>
<p><b>fischer injection system FIS EM Plus</b></p>	
<p><b>Intended use</b> Safety regulations; Installation instruction part 1, hole drilling</p>	<p><b>Annex B 5</b></p>

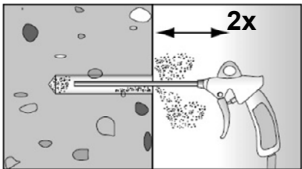
## Installation instruction part 2

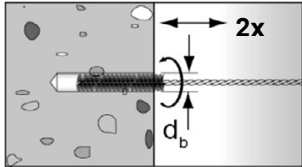
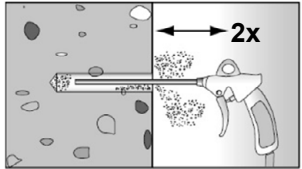
### Drill hole cleaning (hammer drilling with standard drill bit)

		<p>Cleaning the drill hole. Blow out the drill hole twice, with oil free compressed air (<math>p \geq 6</math> bar). If the drill hole depth is greater than the length of the compressed-air cleaning tool, an extension and appropriate fischer cleaning nozzle must be used. Corresponding diameters see <b>table B4.3</b>.</p>	
<p>3a</p>		<p>Brush the drill hole twice. For drill hole diameter <math>\geq 30</math> mm use a power drill. For deep holes use an extension. Corresponding brushes see <b>table B4.3</b>.</p>	
		<p>Cleaning the drill hole: Blow out the drill hole twice, with oil free compressed air (<math>p \geq 6</math> bar). If the drill hole depth is greater than the length of the compressed-air cleaning tool, an extension and appropriate fischer cleaning nozzle must be used. Corresponding diameters see <b>table B4.3</b>.</p>	

Go to step 4

### Drill hole cleaning (hammer drilling with hollow drill bit)

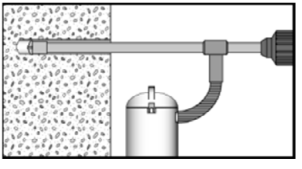
<p>3b</p>		<p>Use a suitable dust extraction system, e. g. fischer FVC 35 M or a comparable dust extraction system with equivalent performance data.  Drill the hole with hollow drill bit. The dust extraction system has to extract the drill dust nonstop during the drilling process and must be adjusted to maximum power. Check the hollow drill for correct operation of the dust extraction. No further cleaning steps necessary.</p>
-----------	---	--

Go to step 4

**fischer injection system FIS EM Plus**

**Intended use**  
Installation instruction part 2, drill hole cleaning

**Annex B 6**

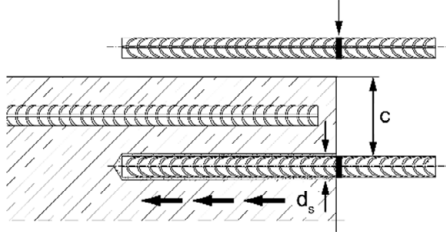
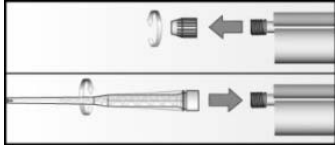
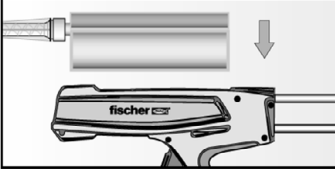
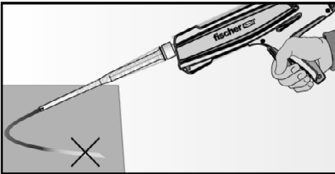
<b>Installation instruction part 3</b> <b>Reinforcing bars (rebar) and cartridge preparation</b>	
4	 <p>Before use, make asure that the rebar is dry and free of oil or other residue. Mark the embedment depth <math>l_b</math> (e.g. with tape) Insert rebar in borehole, to verify drill hole depth and setting depth <math>l_b</math>.</p>
5	 <p>Twist off the sealing cap Twist on the static mixer (the spiral in the static mixer must be clearly visible).</p>
6	 <p>Place the cartridge into a suitable dispenser.</p>
7	 <p>Press out approximately 10 cm of mortar until the resin is permanently grey in colour. Mortar which is not grey in colour will not cure and must be disposed.</p>
Go to step 8	
<b>fischer injection system FIS EM Plus</b>	
<b>Intended use</b> Installation instruction part 3, reinforcing bars (rebar) and cartridge preparation	
<b>Annex B 7</b>	

## Installation instruction part 4; Installation with FIS EM Plus Injection of the mortar without extension tube

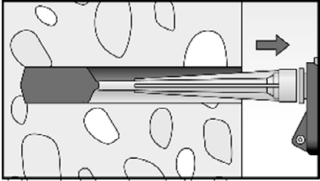
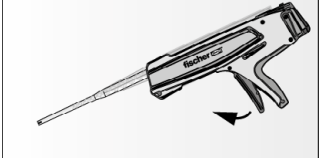
8a		<p>Inject the mortar from the back of the hole towards the front and slowly withdraw the static mixer step by step with each trigger pull. Avoid bubbles.</p> <p>Fill holes approximately 2/3 (for <math>h_0 = l_b</math>) full, to ensure that the annular gap between the rebar and the concrete will be completely filled with adhesive over the entire embedment length. For <math>h_0 &gt; l_b</math> more mortar is needed.</p> <p>The conditions for mortar injection without extension tube can be found in <b>table B4.1</b></p>
		<p>After injecting, release the dispenser. This will prevent further mortar discharge from the static mixer.</p>

## Injection of the mortar with extension tube

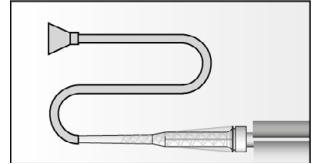
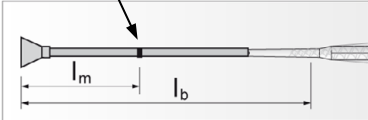
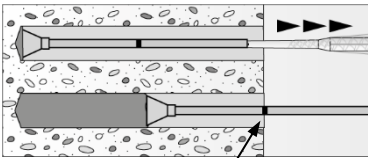
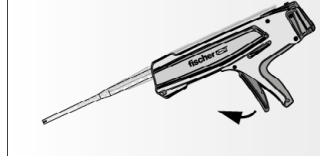



		<p>Assemble mixing nozzle FIS MR Plus or FIS UMR, extension tube and appropriate injection adapter (see <b>table B4.3</b>).</p>
8b	<p>Mortar level mark</p> 	<p>Mark the required mortar level <math>l_m</math> and embedment depth <math>l_b</math> with tape or marker on the injection extension tube.</p> <p>a) Estimation:</p> $l_m = \frac{1}{3} \cdot l_b \text{ [mm]}$ <p>b) Precise equation for optimum mortar volume:</p> $l_m = l_b \cdot \left( 1,2 \cdot \frac{d_s^2}{d_0^2} - 0,2 \right) \text{ [mm]}$
	 <p>Mortar level mark</p>	<p>Insert injection adapter to back of the hole. Begin injection allowing the pressure of the injected adhesive mortar to push the injection adapter towards the front of the hole. Do not actively pull out!</p> <p>Fill holes approximately 2/3 (for <math>h_0 = l_b</math>) full, to ensure that the annular gap between the rebar and the concrete will be completely filled with adhesive over the embedment length. For <math>h_0 &gt; l_b</math> more mortar is needed. When using an injection adapter continue injection until the mortar level mark <math>l_m</math> becomes visible.</p> <p>Maximum embedment depth, see <b>table B3.2</b>.</p>
		<p>After injecting, release the dispenser. This will prevent further mortar discharge from the static mixer.</p>

Go to step 9

**fischer injection system FIS EM Plus**

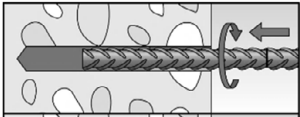
**Intended use**  
Installation instruction part 4, mortar injection

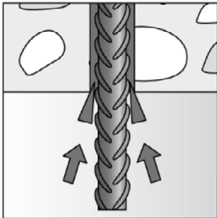
**Annex B 8**

<b>Installation instruction part 5; Installation with FIS EM Plus</b> <b>Insert rebar</b>	
<b>9</b>	 <p>Insert the rebar slowly twisted into the borehole until the embedment mark is reached.                      Recommendation:                      Rotation back and forth of the reinforcement bar makes pushing easy</p>
<b>10</b>	 <p>After installing the rebar the annular gap must be completely filled with mortar.</p> <p>Proper installation</p> <ul style="list-style-type: none"> <li>• Desired embedment depth is reached <math>l_b</math>: embedment mark at concrete surface</li> <li>• Excess mortar flows out of the borehole after the rebar have been fully inserted up to the embedment mark.</li> </ul>
<b>11</b>	 <p>For overhead installation, support the rebar and secure it from falling till mortar started to harden, e.g. using wedges.</p>
<b>12</b>	 <p>Observe the working time "<math>t_{work}</math>" (see <b>table B4.2</b>), which varies according to temperature of base material. Minor adjustments to the rebar position may be performed during the working time</p> <p>Full load may be applied only after the curing time "<math>t_{cure}</math>" has elapsed (see <b>table B4.2</b>)</p>
<p><b>fischer injection system FIS EM Plus</b></p>	
<p><b>Intended use</b> Installation instruction part 5, insert rebar</p>	
<p><b>Annex B 9</b></p>	



<b>Table C1.1: Characteristic resistance under tension loading for reinforcing bars</b>																					
Size		All sizes																			
<b>Characteristic resistance under tension loading</b>																					
Installation factor		$\gamma_{inst}$	[-]		See annex C 2 to C 3																
<b>Factors for the compressive strength of concrete &gt; C20/25</b>																					
Increasing factor $\psi_c$ for cracked or uncracked concrete $\tau_{Rk,C(X/Y)} = \psi_c \cdot \tau_{Rk,C(20/25)}$	C25/30	[-]	1,02																		
	C30/37		1,04																		
	C35/45		1,06																		
	C40/50		1,07																		
	C45/55		1,08																		
	C50/60		1,09																		
<b>Concrete cone failure</b>																					
Uncracked concrete	$k_{ucr,N}$	[-]	11,0																		
Cracked concrete	$k_{cr,N}$		7,7																		
Edge distance	$c_{cr,N}$	[mm]	$1,5 \cdot l_b$																		
Spacing	$s_{cr,N}$		$3 \cdot l_b$																		
<b>Factors for sustained tension loading</b>																					
Factor		$\psi_{sus}^0$	[-]		- <sup>1)</sup>																
1) No performance assessed																					
<b>Table C1.2: Essential characteristics under tension loading for reinforcing bars in hammer drilled holes; uncracked or cracked concrete; working life 50 and 100 years</b>																					
<b>Nominal diameter of the bar</b>		$\phi$	8	10	12	14	16	18	20	22	24	25	26	28	30	32	34	36	40		
<b>Bond-splitting failure for working life of 50 and 100 years</b>																					
Calculation diameter		d	[mm]		8	10	12	14	16	18	20	22	24	25	26	28	30	32	34	36	40
<b>Hammer-drilling with standard drill bit or hollow drill bit for 50 and 100 years</b>																					
Product basic factor		$A_k$	[-]	4,4																	
Exponent for influence of concrete compressive strength		sp1		0,33																	
Exponent for influence of rebar diameter $\phi$		sp2		0,34																	
Exponent for influence of concrete cover $c_d$		sp3		0,62																	
Exponent for influence of side concrete cover ( $c_{max} / c_d$ )		sp4		0,33																	
Exponent for influence of anchorage length $l_b$		lb1		0,68																	
<b>fischer injection system FIS EM Plus</b>																					
<b>Performances</b> Characteristic resistance under tension loading for reinforcing bars; uncracked or cracked concrete; working life 50 and 100 years																					
<b>Annex C 1</b>																					

<b>Table C2.1: Characteristic resistance under tension loading for reinforcing bars in hammer drilled holes; uncracked or cracked concrete; working life 50 years</b>																					
Nominal diameter of the bar	$\phi$	8	10	12	14	16	18	20	22	24	25	26	28	30	32	34	36	40			
<b>Combined pullout and concrete cone failure</b>																					
Calculation diameter	d	[mm]	8	10	12	14	16	18	20	22	24	25	26	28	30	32	34	36	40		
<b>Uncracked concrete</b>																					
<b>Characteristic bond resistance in uncracked concrete C20/25</b>																					
Hammer-drilling with standard drill bit or hollow drill bit (dry or wet concrete)																					
Tem- perature range	I: 35 °C / 60 °C		$\tau_{Rk,ucr,50}$	[N/mm <sup>2</sup> ]	16	15	15	14	14	13	13	13	12	12	12	12	12	11	11	11	
	II: 50 °C / 72 °C				15	14	14	13	13	12	12	12	12	11	11	11	11	11	11	10	10
Hammer-drilling with standard drill bit or hollow drill bit (water filled hole)																					
Tem- perature range	I: 35 °C / 60 °C		$\tau_{Rk,ucr,50}$	[N/mm <sup>2</sup> ]	16	16	14	13	12	12	11	11	10	10	10	10	9	9	9	8	8
	II: 50 °C / 72 °C				15	14	13	12	12	11	11	10	10	9	9	9	9	8	8	8	8
<b>Installation factors</b>																					
Dry or wet concrete	$\gamma_{inst}$	[-]	1,0																		
Water filled hole			1,4																		
<b>Influence of cracked concrete on combined pullout and concrete cone failure for working life of 50 years</b>																					
Hammer-drilling with standard drill bit or hollow drill bit																					
Factor for influence of cracked concrete	$\Omega_{cr,03}$	[-]	0,91	0,91	0,91	0,91	0,91	0,91	0,92	0,92	0,92	0,92	0,92	0,92	0,92	0,93	0,93	0,93	0,93		
<b>fischer injection system FIS EM Plus</b>																					
<b>Performances</b>																					
Characteristic resistance under tension loading for reinforcing bars; uncracked or cracked concrete; working life 50 years																					
<b>Annex C 2</b>																					

<b>Table C3.1: Characteristic resistance under tension loading for reinforcing bars in hammer drilled holes; uncracked or cracked concrete; working life 100 years</b>																					
Nominal diameter of the bar $\phi$		8	10	12	14	16	18	20	22	24	25	26	28	30	32	34	36	40			
<b>Combined pullout and concrete cone failure</b>																					
Calculation diameter d		[mm]	8	10	12	14	16	18	20	22	24	25	26	28	30	32	34	36	40		
<b>Uncracked concrete</b>																					
<b>Characteristic bond resistance in uncracked concrete C20/25 <sup>1)</sup></b>																					
Hammer-drilling with standard drill bit or hollow drill bit (dry or wet concrete)																					
Tem- perature range	I: 35 °C / 60 °C		$\tau_{Rk,ucr,50}$	[N/mm <sup>2</sup> ]	16	15	15	14	14	13	13	13	12	12	12	12	12	11	11	11	
	II: 50 °C / 72 °C				15	14	14	13	13	12	12	12	12	11	11	11	11	11	11	10	10
<b>Installation factors</b>																					
Dry or wet concrete		$\gamma_{inst}$	[-]	1,0																	
Tem- perature range	I: 35 °C / 60 °C		$\alpha_{100\text{ years}}$	[-]	0,55	0,75	0,60	0,75	0,60	0,75	0,65	0,75	0,65	0,75	0,65	0,75	0,65	0,75	0,65	0,75	
	II: 50 °C / 72 °C				0,55	0,75	0,60	0,75	0,60	0,75	0,65	0,75	0,65	0,75	0,65	0,75	0,65	0,75	0,65	0,75	0,65
<b>Influence of cracked concrete on combined pullout and concrete cone failure for working life of 100 years</b>																					
Hammer-drilling with standard drill bit or hollow drill bit (dry or wet concrete)																					
Factor for influence of cracked concrete		$\Omega_{cr,03}$	[-]	0,91	0,91	0,91	0,91	0,91	0,91	0,91	0,92	0,92	0,92	0,92	0,92	0,92	0,92	0,93	0,93	0,93	0,93
<p><b>1) Calculation of characteristic bond resistance in uncracked concrete <math>\tau_{Rk,100, ucr}</math>:</b></p> $\tau_{Rk,100, ucr} = \alpha_{100\text{ years}} \cdot \tau_{Rk,ucr,50}$																					
<b>fischer injection system FIS EM Plus</b>														<b>Annex C 3</b>							
<b>Performances</b> Characteristic resistance under tension loading for reinforcing bars; uncracked or cracked concrete; working life 100 years																					

<b>Table C4.1: Characteristic resistance under tension loading for reinforcing bars (rebars) in concrete under seismic action; working life of 50 and 100 years</b>																		
Nominal diameter of the bar	$\phi$	8	10	12	14	16	18	20	22	24	25	26	28	30	32	34	36	40
<b>Resistance to pull-out failure in uncracked concrete under cyclic loading for working life of 50 and 100 years</b>																		
Hammer-drilling with standard drill bit or hollow drill bit (dry or wet concrete)																		
Reduction factor for pull-out Resistance under seismic action	$\alpha_{eq,p}$	[N/mm <sup>2</sup> ]	0,76										1,0					
<b>Influence of increased crack width on resistance to pull-out failure for working life of 50 and 100 years</b>																		
Hammer-drilling with standard drill bit or hollow drill bit (dry or wet concrete)																		
Factor for influence of cracked concrete	$\Omega_{cr,05}^{1)}$	[-]	0,86	0,86	0,86	0,86	0,86	0,86	0,86	0,86	0,86	0,86	0,86	0,86	0,87	0,87	0,87	0,87
	$\Omega_{cr,08}^{1)}$		0,76	0,76	0,76	0,76	0,76	0,76	0,76	0,76	0,76	0,76	0,76	0,76	0,76	0,76	0,73	0,70
<b>Resistance to bond-splitting failure under cyclic loading for working life of 50 and 100 years</b>																		
Hammer-drilling with standard drill bit or hollow drill bit (dry or wet concrete)																		
Reduction factor for bond-splitting resistance under seismic action	$\alpha_{eq,sp}$	[-]	0,94															
<p>1) Assumed crack width in accordance with EOTA Technical Report TR 069 June 2021; Section 3.6.</p>																		
<b>fischer injection system FIS EM Plus</b>															<b>Annex C 4</b>			
<b>Performances</b> Characteristic resistance under tension loading for reinforcing bars (rebars) in concrete under seismic action working life of 50 and 100 years																		