

Approval body for construction products
and types of construction

Bautechnisches Prüfamt

An institution established by the Federal and
Laender Governments



European Technical Assessment

ETA-22/0887
of 24 February 2023

English translation prepared by DIBt - Original version in German language

General Part

Technical Assessment Body issuing the
European Technical Assessment:

Deutsches Institut für Bautechnik

Trade name of the construction product

BORGH TAC VS-Schroeven and TAC VS-Dakschroeven

Product family
to which the construction product belongs

Screws for use in timber constructions

Manufacturer

Borgh B.V.
De Steiger 71-73
1351 AE ALMERE
NIEDERLANDE

Manufacturing plant

Hersteller 1, Hersteller 2, Hersteller 3, Hersteller 4,
Hersteller 5

This European Technical Assessment
contains

31 pages including 4 annexes which form an integral part
of this assessment

This European Technical Assessment is
issued in accordance with Regulation (EU)
No 305/2011, on the basis of

EAD 130118-01-0603 – SCREWS AND THREADED
RODS FOR USE IN TIMBER CONSTRUCTIONS

The European Technical Assessment is issued by the Technical Assessment Body in its official language. Translations of this European Technical Assessment in other languages shall fully correspond to the original issued document and shall be identified as such.

Communication of this European Technical Assessment, including transmission by electronic means, shall be in full. However, partial reproduction may only be made with the written consent of the issuing Technical Assessment Body. Any partial reproduction shall be identified as such.

This European Technical Assessment may be withdrawn by the issuing Technical Assessment Body, in particular pursuant to information by the Commission in accordance with Article 25(3) of Regulation (EU) No 305/2011.

Specific Part

1 Technical description of the product

BORGH TAC VS-Schroeven and TAC VS-Dakschroeven are self-tapping screws made from special carbon steel. They are hardened. They have a corrosion protection given in Annex A.2.6. The outer thread diameter is not less than 3.5 mm and not greater than 10.0 mm. The overall length of the screws is ranging from 30 mm to 400 mm. Further dimensions are shown in Annex 4. They have an anti-friction coating. The washers are made from carbon steel. The dimensions of the washers are given in Annex 4.1.

BORGH TAC VS-Schroeven and TAC VS-Dakschroeven achieve a bending angle α of at least $45/d^{0.7} + 20$, where d is the outer thread diameter of the screws.

2 Specification of the intended use in accordance with the applicable European Assessment Document

The performances given in Section 3 are only valid if the screws are used in compliance with the specifications and conditions given in Annex 1 to 3.

The verifications and assessment methods on which this European Technical Assessment is based lead to the assumption of a working life of the screws of at least 50 years. The indications given on the working life cannot be interpreted as a guarantee given by the producer, but are to be regarded only as a means for choosing the right products in relation to the expected economically reasonable working life of the works.

3 Performance of the product and references to the methods used for its assessment

3.1 Mechanical resistance and stability (BWR 1)

Essential characteristic	Performance
Dimensions	See Annex 4
Characteristic yield moment	See Annex 2
Bending angle	See Annex 2
Characteristic withdrawal parameter	See Annex 2
Characteristic head pull-through parameter	See Annex 2
Characteristic tensile strength	See Annex 2
Characteristic yield strength	No performance determined
Characteristic torsional strength	See Annex 2
Insertion moment	See Annex 2
Spacings, end and edge distances of the screws and minimum thickness of the wood-based materials	See Annex 2
Slip modulus for mainly axially loaded screws	See Annex 2
Durability against corrosion	See Annex 2

English translation prepared by DIBt

3.2 Safety in case of fire (BWR 2)

Essential characteristic	Performance
Reaction to fire	Class A1

3.3 Safety and accessibility in use (BWR 4)

Same as BWR 1.

4 Assessment and verification of constancy of performance (AVCP) system applied, with reference to its legal base

In accordance with EAD No. 130118-01-0603 the applicable European legal act is: 97/176/EC.
The system to be applied is: 3

5 Technical details necessary for the implementation of the AVCP system, as provided for in the applicable EAD

Technical details necessary for the implementation of the AVCP system are laid down in the control plan deposited with Deutsches Institut für Bautechnik.

Issued in Berlin on 24 February 2023 by Deutsches Institut für Bautechnik

Anja Dewitt
Head of Section

beglaubigt:
Blümel

Annex 1 Specifications of intended use

A.1.1 Use of the BORGH TAC VS-Schroeven and TAC VS-Dakschroeven only for:

- static and quasi-static loads

A.1.2 Connection material

The screws are used for connections in load-bearing timber structures between wood-based members or between wood-based members and steel members:

- Solid timber (softwood) in accordance with EN 14081-1¹,
- Glued laminated timber in accordance with EN 14080²,
- Glued solid timber in accordance with EN 14080,
- Laminated veneer lumber LVL (softwood) in accordance with EN 14374³, arrangement of the screws only perpendicular to the plane of the veneers,
- Cross laminated timber (softwood) in accordance with European Technical Assessments.

The screws are used for connecting the following wood-based panels to the timber members mentioned above:

- Plywood in accordance with EN 636⁴ and EN 13986⁵,
- Oriented strand boards (OSB) in accordance with EN 300⁶ and EN 13986,
- Particleboards in accordance with EN 312⁷ and EN 13986,
- Fibreboards in accordance with EN 622-2⁸, EN 622-3⁹ and EN 13986,
- Cement-bonded particleboards in accordance with EN 634-2¹⁰ and EN 13986,
- Solid wood panels (SWP) in accordance with EN 13353¹¹ and EN 13986.

Wood-based panels are only arranged on the side of the screw head.

BORGH TAC VS-Schroeven and TAC VS-Dakschroeven with an outer thread diameter of at least 6 mm are also used for the fixing of thermal insulation material on top of rafters or on wood-based members in vertical façades.

1	EN 14081-1:2005+A1:2011	Timber structures – Strength graded structural timber with rectangular cross section – Part 1: General requirements
2	EN 14080:2013	Timber structures – Glued laminated timber and glued solid timber – Requirements
3	EN 14374:2004	Timber structures – Structural laminated veneer lumber – Requirements
4	EN 636:2012+A1:2015	Plywood – Specifications
5	EN 13986:2004+A1:2015	Wood-based panels for use in construction – Characteristics, evaluation of conformity and marking
6	EN 300:2006	Oriented strand boards (OSB) – Definition, classification and specifications
7	EN 312:2010	Particleboards – Specifications
8	EN 622-2:2004/AC:2005	Fibreboards – Specifications – Part 2: Requirements for hardboards
9	EN 622-3:2004	Fibreboards – Specifications – Part 3: Requirements for medium boards
10	EN 634-2:2007	Cement-bonded particleboards – Specifications – Part 2: Requirements for OPC bonded particleboards for use in dry, humid and external conditions
11	EN 13353:2022	Solid wood panels (SWP) – Requirements

BORGH TAC VS-Schroeven and TAC VS-Dakschroeven	Annex 1
Specifications of intended use	

A.1.3 Use Conditions (environmental conditions)

The corrosion protection of the BORGH TAC VS-Schroeven and TAC VS-Dakschroeven is specified in Annex A.2.6.

A.1.4 Installation provisions

EN 1995-1-1¹² applies for the installation of BORGH TAC VS-Schroeven and TAC VS-Dakschroeven.

A minimum of two screws is used for connections in load-bearing timber structures.

The screws are driven into the wood-based member made of softwood without pre-drilling.

The screw holes in steel members shall be pre-drilled with an adequate diameter greater than the outer thread diameter.

If screws with an outer thread diameter $d \geq 8$ mm are driven into the wood-based member without pre-drilling, the structural solid timber, glued laminated timber, glued solid timber, laminated veneer lumber and cross laminated timber is be from spruce, pine or fir.

In the case of fastening counter battens on thermal insulation material on top of rafters the screws are driven in the rafter through the counter battens and the thermal insulation material without pre-drilling in one sequence.

Countersunk head screws may be used with washers in accordance with Annex 4.1 After inserting the screw, the washers shall touch the surface of the wood-based member completely.

By fastening screws in wood-based members the head of the screws is flush with the surface of the wood-based member. For wafer head screws the head part remains unconsidered.

¹² EN 1995-1-1: 2004/AC:2006 Eurocode 5: Design of timber structures – Part 1-1: General – Common rules and rules for buildings
+A1:2008+A2:2014

BORGH TAC VS-Schroeven and TAC VS-Dakschroeven	Annex 1
Installation provisions	

Annex 2 Characteristic values of the load-carrying capacities

Table A.2.1 Characteristic load-carrying capacities of BORGH TAC VS-Schroeven and TAC VS-Dakschroeven

Outer thread diameter d [mm]	3.5	4.0	4.5	5.0	6.0	8.0	10.0
Characteristic yield moment $M_{y,k}$ [Nm]	2.5	3.3	4.5	5.9	9.5	22.0	36.0
Characteristic tensile strength $f_{tens,k}$ [kN]	4.3	5.7	7.2	8.8	12.0	15.0	31.0
Characteristic torsional strength $f_{tor,k}$ [Nm]	2.4	3.5	5.0	7.0	10.0	25.0	45.0

A.2.1 General

All BORGH TAC VS-Schroeven and TAC VS-Dakschroeven achieve a bending angle α of at least $45/d^{0.7} + 20$, where d is the outer thread diameter of the screws.

The minimum penetration length of the threaded part of the screw in the wood-based member l_{ef} is:

$$l_{ef} = \min \left\{ \begin{array}{l} \frac{4 \cdot d}{\sin \alpha} \\ 20 \cdot d \end{array} \right. \quad (2.1)$$

Where

α angle between screw axis and grain direction [°],

d outer thread diameter of the screw [mm].

The outer thread diameter of screws d inserted in cross laminated timber is at least 6 mm. The inner thread diameter d_1 of the screws is greater than the maximal width of the gaps in the layer of cross laminated timber.

A.2.2 Laterally loaded screws

A.2.2.1 General

The outer thread diameter d is used as effective diameter of the screw in accordance with EN 1995-1-1.

The embedding strength for the screws in wood-based members or in wood-based panels can be taken from EN 1995-1-1, unless otherwise specified in the following.

BORGH TAC VS-Schroeven and TAC VS-Dakschroeven	Annex 2
Characteristic values of the load-carrying capacities	

A.2.2.2 Cross laminated timber

The embedding strength for screws arranged in the narrow faces parallel to the plane of cross laminated timber may be assumed in accordance with equation (2.2) independent of the angle between screw axis and grain direction, $0^\circ \leq \alpha \leq 90^\circ$:

$$f_{h,k} = 20 \cdot d^{-0,5} \quad [\text{N/mm}^2] \quad (2.2)$$

unless otherwise specified in the technical specification of the cross laminated timber.

Where d is the outer thread diameter of the screws in mm.

Equation (2.2) is only valid for softwood layers. The provisions in the European Technical Assessment of the cross laminated timber apply.

The embedding strength for screws in the wide face of cross laminated timber should be assumed as for solid timber based on the characteristic density of the outer layer. Where applicable, the angle between force and grain direction of the outer layer shall be taken into account. The direction of the lateral force shall be perpendicular to the screw axis and parallel to the wide face of the cross laminated timber.

For angles $45^\circ \leq \alpha < 90^\circ$ between screw axis and grain direction of the outer layer the characteristic load-carrying capacity may be assumed as 2/3 of the corresponding value for $\alpha = 90^\circ$, if only the penetration depth perpendicular to the wide face is taken into account.

A.2.3 Axially loaded screws

A.2.3.1 Slip modulus for axially loaded screws

The axial slip modulus K_{ser} of the threaded part of a screw for the serviceability limit state shall be taken independent of angle α to the grain as:

$$K_{ser} = 780 \cdot d^{0,2} \cdot l_{ef}^{0,4} \quad [\text{N/mm}] \quad (2.3)$$

Where

d outer thread diameter of the screw [mm],

l_{ef} penetration length of the threaded part of the screw in the wood-based member [mm].

A.2.3.2 Axial withdrawal capacity – Characteristic withdrawal parameter

The characteristic withdrawal capacity of BORGH TAC VS-Schroeven and TAC VS-Dakschroeven in solid timber, glued laminated timber, cross laminated timber or laminated veneer lumber members made from softwood at an angle of $15^\circ \leq \alpha \leq 90^\circ$ to the grain shall be calculated as:

$$F_{ax,\alpha,Rk} = n_{ef} \cdot k_{ax} \cdot f_{ax,k} \cdot d \cdot l_{ef} \cdot \left(\frac{\rho_k}{350} \right)^{0,8} \quad (2.4)$$

Where

$F_{ax,\alpha,Rk}$ characteristic withdrawal capacity of a screw group at an angle α to the grain [N],

n_{ef} effective number of screws in accordance with EN 1995-1-1, clause 8.7.2 (8),

For inclined screws with an angle between shear plane and screw axis $30^\circ \leq \alpha \leq 60^\circ$:

$$n_{ef} = \max \{ n^{0,9}; 0,9 \cdot n \} \quad (2.5)$$

For inclined screws as fasteners in mechanically jointed beams or columns or for the fixing of thermal insulation material, $n_{ef} = n$.

BORGH TAC VS-Schroeven and TAC VS-Dakschroeven	Annex 2
Characteristic values of the load-carrying capacities	

English translation prepared by DIBt

- n Number of screws acting together in a connection. If crossed pairs of screws are used in timber-to-timber connections, n is the number of crossed pairs of screws.
- k_{ax} factor, taking into account the angle α between screw axis and grain direction
- $$k_{ax} = 1.0 \quad \text{for } 45^\circ \leq \alpha \leq 90^\circ$$
- $$k_{ax} = 0.3 + \frac{0.7 \cdot \alpha}{45^\circ} \quad \text{for } 15^\circ \leq \alpha < 45^\circ \quad (2.6)$$
- $f_{ax,k}$ characteristic withdrawal parameter at an angle $\alpha = 90^\circ$ based on a characteristic density of the wood-based member ρ_k of 350 kg/m³:
- $f_{ax,k} = 14.0$ N/mm² for BORGH TAC VS-Schroeven and TAC VS-Dakschroeven with 3.5 mm ≤ d ≤ 4.5 mm
- $f_{ax,k} = 13.0$ N/mm² for BORGH TAC VS-Schroeven and TAC VS-Dakschroeven with $d = 5.0$ mm
- $f_{ax,k} = 12.0$ N/mm² for BORGH TAC VS-Schroeven and TAC VS-Dakschroeven with $d = 6.0$ mm
- $f_{ax,k} = 10.5$ N/mm² for BORGH TAC VS-Schroeven and TAC VS-Dakschroeven with $d > 6.0$ mm
- The characteristic withdrawal parameter is also valid for softwood layers of cross laminated timber.
- d outer thread diameter of the screw [mm],
- l_{ef} penetration length of the threaded part of the screw in the wood-based member [mm],
- ρ_k characteristic density of the wood-based member, for LVL $\rho_k \leq 500$ kg/m³.

For screws penetrating more than one layer of cross laminated timber the different layers may be taken into account proportionally. In the lateral surfaces of the cross laminated timber the screws shall be fully inserted in one layer of cross laminated timber.

A.2.3.3 Head pull-through capacity – Characteristic head pull-through parameter

The characteristic value of the head pull-through parameter for BORGH TAC VS-Schroeven and TAC VS-Dakschroeven for a characteristic density of 350 kg/m³ of the timber and for wood-based panels like

- Plywood in accordance with EN 636 and EN 13986,
- Oriented strand boards (OSB) in accordance with EN 300 and EN 13986,
- Particleboards in accordance with EN 312 and EN 13986,
- Fibreboards in accordance with EN 622-2, EN 622-3 and EN 13986,
- Cement-bonded particleboards in accordance with EN 634-2 and EN 13986,
- Solid wood panels (SWP) in accordance with EN 13353 and EN 13986

with a thickness of more than 20 mm is

$f_{head,k} = 12.0$ N/mm² for $d_h \leq 22$ mm and

$f_{head,k} = 10.0$ N/mm² for $d_h > 22$ mm with d_h as screw head or washer diameter.

For wood-based panels a maximum characteristic density of 380 kg/m³ and for LVL a maximum characteristic density of 500 kg/m³ shall be used in equation (8.40b) of EN 1995-1-1.

The head diameter shall be equal to or greater than 1.8· d_s , where d_s is the smooth shank or for fully threaded screws the inner thread diameter. Otherwise the characteristic head pull-through capacity in equation (8.40b) of EN 1995-1-1 is: $F_{ax,\alpha,Rk} = 0$ for all wood-based materials.

BORGH TAC VS-Schroeven and TAC VS-Dakschroeven	Annex 2
Characteristic values of the load-carrying capacities	

For wood-based panels with a thickness $12 \text{ mm} \leq t \leq 20 \text{ mm}$ the characteristic value of the head pull-through parameter for the screws is:

$$f_{\text{head,k}} = 8.0 \text{ N/mm}^2.$$

For wood-based panels with a thickness of less than 12 mm the characteristic head pull-through capacity for screws shall be based on a characteristic value of the head pull-through parameter of 8.0 N/mm². The head pull-through capacity shall be limited to 400 N. A minimum thickness of the wood-based panels of 1.2·d, where d is the outer thread diameter, and the values in Table A.2.2 shall be complied.

Table A.2.2 Minimum thickness of wood-based panels

Wood-based panel	Minimum thickness [mm]
Plywood	6
Fibreboards (hardboards and medium boards)	6
Oriented strand boards (OSB)	8
Particleboards	8
Cement-bonded particleboards	8
Solid wood panels (SWP)	12

In steel-to-timber connections the head pull-through capacity is not governing.

BORGH TAC VS-Schroeven and TAC VS-Dakschroeven	Annex 2
Characteristic values of the load-carrying capacities	

A.2.4 Spacings, end and edge distances of the screws and minimum thickness

A.2.4.1 Laterally or laterally *and* axially loaded screws

Screws in non pre-drilled holes

For BORGH TAC VS-Schroeven and TAC VS-Dakschroeven in non pre-drilled holes the minimum spacings, end and edge distances are given in EN 1995-1-1, clause 8.3.1.2 and Table 8.2 as for nails in non-predrilled holes. Here, the outer thread diameter d shall be considered.

Minimum thickness for structural members made from solid timber, glued laminated timber, glued solid timber, laminated veneer lumber and cross laminated timber is $t = 24$ mm for screws with $d \leq 6$ mm, $t = 30$ mm for screws with $d = 8$ mm and $t = 40$ mm for screws with $d = 10$ mm, if the spacing parallel to the grain and the end distance is at least $25 \cdot d$. In all other cases minimum member thicknesses are given in EN 1995-1-1, clause 8.3.1.2 as for nails in non-predrilled holes.

For Douglas fir members minimum spacings and distances parallel to the grain shall be increased by 50 %.

Minimum distances from loaded or unloaded ends shall be at least $15 \cdot d$ for screws with outer thread diameter $d \geq 8$ mm and timber thickness $t < 5 \cdot d$.

Minimum distances from the unloaded edge perpendicular to the grain may be reduced to $3 \cdot d$ also for timber thickness $t < 5 \cdot d$, if the spacings parallel to the grain and the end distance is at least $25 \cdot d$.

A.2.4.2 Only axially loaded screws

For BORGH TAC VS-Schroeven and TAC VS-Dakschroeven the minimum spacings, end and edge distances as well as the minimum member thickness are given in EN 1995-1-1, clause 8.3.1.2 and Table 8.2 as for nails in non-predrilled holes and clause 8.7.2, Table 8.6.

A.2.4.3 Cross laminated timber

The minimum requirements for spacings, end and edge distances of screws in the wide or narrow faces of cross laminated timber are summarised in Table A.2.3. The definition of spacings, end and edge distances is shown in Figure A.2.1 and Figure A.2.2. The minimum spacings, end and edge distances in the narrow faces are independent of the angle between screw axis and grain direction. They shall be used based on the following conditions:

- Minimum thickness of the cross laminated timber: $10 \cdot d$
- Minimum penetration depth in the narrow faces of the cross laminated timber: $10 \cdot d$

For load components perpendicular to the wide faces (see Figure A.2.2 right) the tensile stresses perpendicular to the grain should be transferred by reinforcing screws.

Table A.2.3 Minimum spacings, end and edge distances of screws in the wide or narrow faces of cross laminated timber

	a_1	$a_{3,t}$	$a_{3,c}$	a_2	$a_{4,t}$	$a_{4,c}$
Wide faces (see Figure A.2.1)	$4 \cdot d$	$6 \cdot d$	$6 \cdot d$	$2.5 \cdot d$	$6 \cdot d$	$2.5 \cdot d$
Narrow faces (see Figure A.2.2)	$10 \cdot d$	$12 \cdot d$	$7 \cdot d$	$4 \cdot d$	$6 \cdot d$	$3 \cdot d$

BORGH TAC VS-Schroeven and TAC VS-Dakschroeven	Annex 2
Spacings, end and edge distances and minimum thickness	

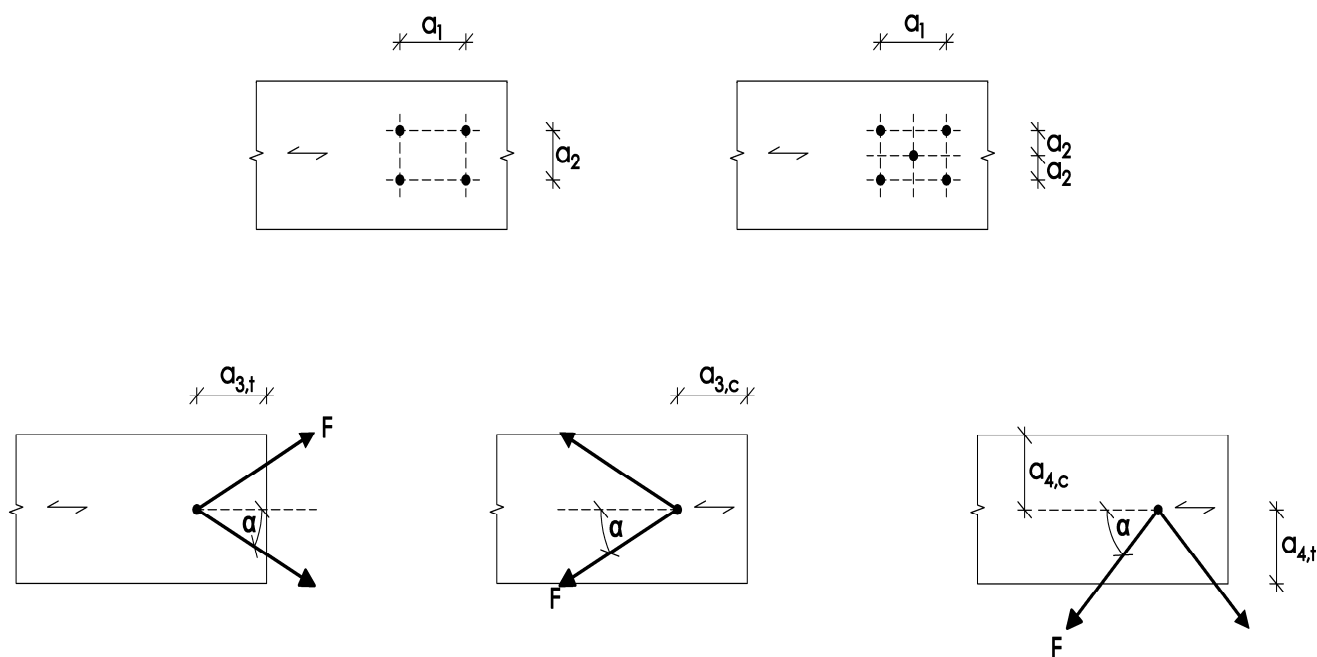

Figure A.2.1 Definition of spacings, end and edge distances in the wide faces of the cross laminated timber

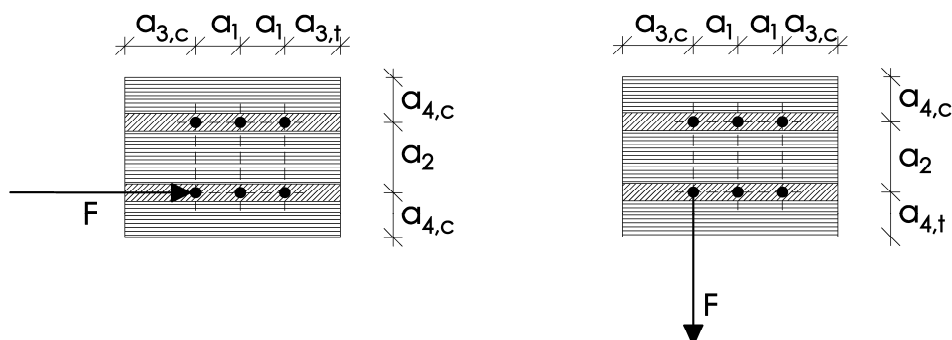

Figure A.2.2 Definition of spacings, end and edge distances in the narrow faces of the cross laminated timber. For screws in the narrow faces, a_1 and a_3 are parallel to the CLT wide face, a_2 and a_4 perpendicular to CLT wide face.

BORGH TAC VS-Schroeven and TAC VS-Dakschroeven	Annex 2
Spacings, end and edge distances	

A.2.5 Insertion moment

The ratio between the characteristic torsional strength $f_{tor,k}$ and the mean value of insertion moment $R_{tor,mean}$ fulfills the requirement for all BORGH TAC VS-Schroeven and TAC VS-Dakschroeven.

A.2.6 Durability against corrosion

Screws and washers made from carbon steel may have the coatings given in Table A.2.4

Table A.2.4 Coatings of the BORGH TAC VS-Schroeven and TAC VS-Dakschroeven

Coating		Mean thickness of the coating [μm]
electrogalvanised	blue chromaed	6
	yellow chromated	
Zinc flake basecoat		5

BORGH TAC VS-Schroeven and TAC VS-Dakschroeven	Annex 2
Insertion moment and durability against corrosion	

Annex 3 Fastening of thermal insulation material on top of rafters (informative)

A.3.1 General

BORGH TAC VS-Schroeven and TAC VS-Dakschroeven with an outer thread diameter of at least 6 mm may be used for the fixing of thermal insulation material on top of rafters or on wood-based members in vertical façades. In the following, the meaning of the word rafter includes wood-based members with inclinations between 0° and 90°.

The thickness of the thermal insulation material is up to 300 mm. The thermal insulation material is applicable as insulation on top of rafters or on wood-based members in vertical façades.

The counter battens are from solid timber in accordance with EN 14081-1. The minimum thickness t and the minimum width b of the counter battens are given in Table A.3.1:

Table A.3.1 Minimum thickness and minimum width of the counter battens

Outer thread diameter [mm]	Minimum thickness t [mm]	Minimum width b [mm]
6 and 8	30	50
10	40	60

Instead of battens the wood-based panels specified in chapter A.3.2.1 may be used. Only screws with flat head are used for fixing wood-based panels on rafters with thermal insulation material as interlayer.

The minimum width of the rafters is 60 mm.

The spacing between screws e_s is not more than 1.75 m.

Friction forces are not considered for the design of the characteristic axial withdrawal capacity of the screws.

The anchorage of wind suction forces shall be considered for design. Screws perpendicular to the grain of the rafter may be arranged where required.

A.3.2 Parallel inclined screws and thermal insulation material in compression

A.3.2.1 Mechanical model

The system of rafter, thermal insulation material on top of rafter and counter battens parallel to the rafter can be considered as a beam on elastic foundation. The counter batten represents the beam, and the thermal insulation material on top of the rafter the elastic foundation. The minimum compressive stress of the thermal insulation material at 10 % deformation, measured in accordance with EN 826¹³, shall be $\sigma_{10\%} = 0.05 \text{ N/mm}^2$. The counter batten is loaded perpendicular to the axis by point loads F_b transferred by regularly spaced counter battens. Further point loads F_s are caused by the shear load of the roof due to dead and snow load, which are transferred from the screw heads into the counter battens.

Instead of battens the following wood-based panels may be used to cover the thermal insulation material if they are suitable for that use:

- Plywood in accordance with EN 636 and EN 13986,
- Oriented strand boards (OSB) in accordance with EN 300 and EN 13986,
- Particleboards in accordance with EN 312 and EN 13986,
- Fibreboards in accordance with EN 622-2, EN 622-3 and EN 13986.

The minimum thickness of the wood-based panels is 22 mm.

The word counter batten includes the meaning of the wood-based panels in the following.

¹³ EN 826:2013 Thermal insulating products for building applications – Determination of compression behaviour

BORGH TAC VS-Schroeven and TAC VS-Dakschroeven	Annex 3
Fastening of thermal insulation material on top of rafters	

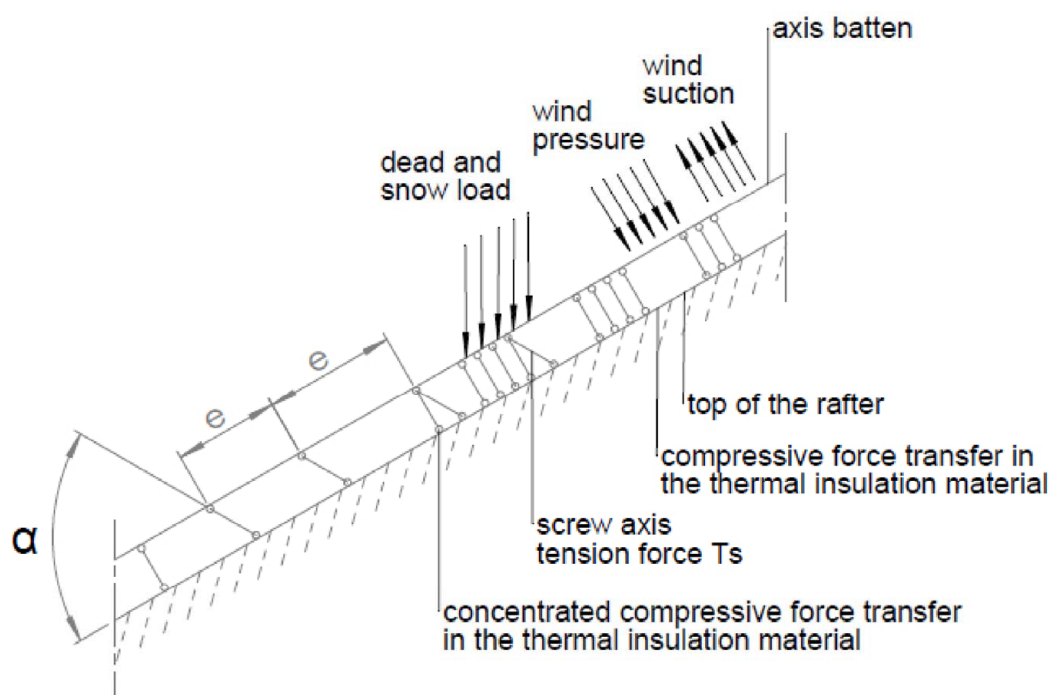
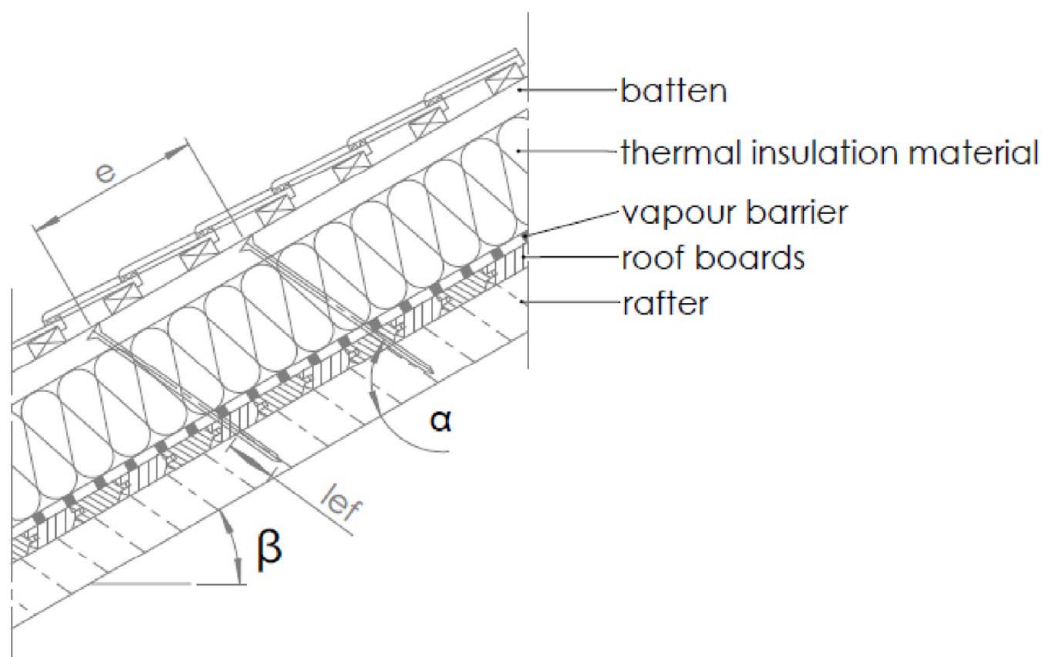

Figure A.3.1 Fastening of the thermal insulation material on top of rafters - structural system

BORGH TAC VS-Schroeven and TAC VS-Dakschroeven	Annex 3
Fastening of thermal insulation material on top of rafters	

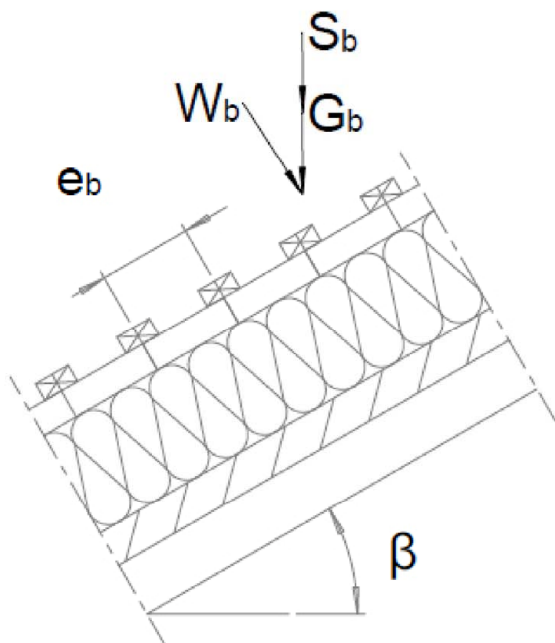

Figure A.3.2:
Point loads F_b perpendicular to the battens

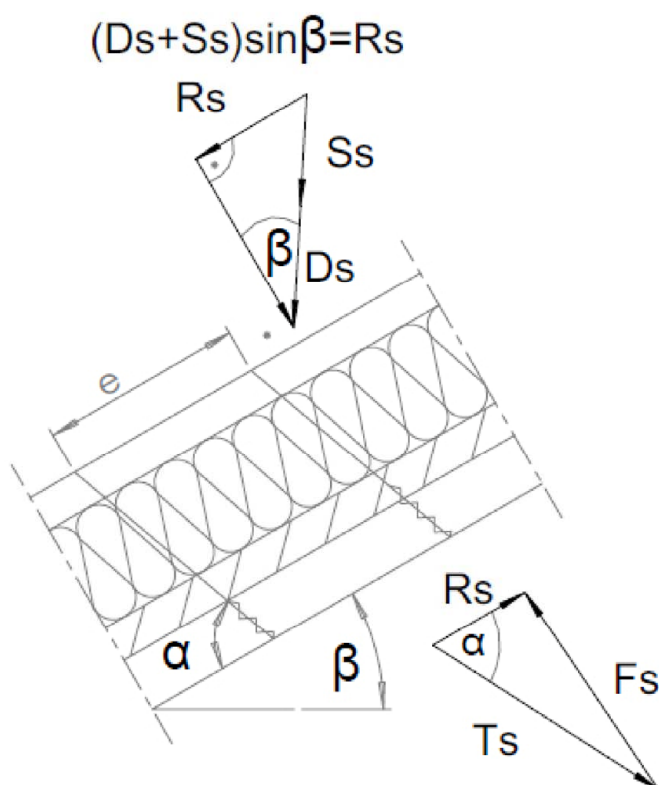

Figure A.3.3:
Point loads F_s perpendicular
to the battens,
load application in the area
of the screw heads

Electronic copy of the ETA by DIBt: ETA-22/0887

BORGH TAC VS-Schroeven and TAC VS-Dakschroeven	Annex 3
Fastening of thermal insulation material on top of rafters	

A.3.2.2 Design of the battens

It's assumed that the spacing between the counter battens exceeds the characteristic length l_{char} .
The characteristic values of the bending stresses may be calculated as:

$$M_k = \frac{(F_{b,k} + F_{s,k}) \cdot l_{char}}{4} \quad (3.1)$$

Where

$$l_{char} \quad \text{characteristic length} \quad l_{char} = 4 \sqrt{\frac{EI}{w_{ef} \cdot K}} \quad (3.2)$$

EI bending stiffness of the counter batten,

K modulus of subgrade reaction,

w_{ef} effective width of the thermal insulation material,

$F_{b,k}$ point loads perpendicular to the counter battens,

$F_{s,k}$ point loads perpendicular to the counter battens, load application in the area of the screw heads.

The modulus of subgrade reaction K can be calculated from the modulus of elasticity E_{HI} and the thickness t_{HI} of the thermal insulation material if the effective width w_{ef} of the thermal insulation material under compression is known. Due to the load extension in the thermal insulation material the effective width w_{ef} is greater than the width of the counter batten or rafter, respectively. For further calculations, the effective width w_{ef} of the thermal insulation material may be determined in accordance with:

$$w_{ef} = w + t_{HI} / 2 \quad (3.3)$$

Where

w minimum from width of the counter batten or rafter, respectively,

t_{HI} thickness of the thermal insulation material

$$K = \frac{E_{HI}}{t_{HI}} \quad (3.4)$$

The following condition shall be satisfied:

$$\frac{\sigma_{m,d}}{f_{m,d}} = \frac{M_d}{W \cdot f_{m,d}} \leq 1 \quad (3.5)$$

For the calculation of the section modulus W the net cross section shall be considered.

The characteristic values of the shear stresses shall be calculated as:

$$V_k = \frac{(F_b + F_s)}{2} \quad (3.6)$$

The following condition need to be satisfied:

$$\frac{\tau_d}{f_{v,d}} = \frac{1.5 \cdot V_d}{A \cdot f_{v,d}} \leq 1 \quad (3.7)$$

For the calculation of the cross section area the net cross section shall be considered.

BORGH TAC VS-Schroeven and TAC VS-Dakschroeven	Annex 3
Fastening of thermal insulation material on top of rafters	

A.3.2.3 Design of the thermal insulation material

The characteristic value of the compressive stresses in the thermal insulation material may be calculated as:

$$\sigma_k = \frac{1.5 \cdot F_{b,k} + F_{s,k}}{2 \cdot l_{char} \cdot w} \quad (3.8)$$

The design value of the compressive stress shall not be greater than 110 % of the compressive strength at 10 % deformation calculated in accordance with EN 826.

A.3.2.4 Design of the screws

The screws are loaded predominantly axial. The characteristic value of the axial tension force in the screw may be calculated from the shear loads of the roof R_s :

$$T_{S,k} = \frac{R_{S,k}}{\cos \alpha} \quad (3.9)$$

The load-carrying capacity of axially loaded screws is the minimum design value of the axial withdrawal capacity of the threaded part of the screw, the head pull-through capacity of the screw and the tensile strength of the screw in accordance with Annex 2.

In order to limit the deformation of the screw head for thermal insulation material with thickness over 220 mm or with compressive strength below 0.12 N/mm², respectively, the axial withdrawal capacity of the screws shall be reduced by the factors k_1 and k_2 :

$$F_{ax,\alpha,Rd} = \min \left\{ \frac{k_{ax} \cdot f_{ax,d} \cdot d \cdot l_{ef} \cdot k_1 \cdot k_2}{1.2 \cdot \cos^2 \alpha + \sin^2 \alpha} \cdot \left(\frac{\rho_k}{350} \right)^{0.8}; f_{head,d} \cdot d_h^2 \cdot \left(\frac{\rho_k}{350} \right)^{0.8}; \frac{f_{tens,k}}{\gamma_{M2}} \right\} \quad (3.10)$$

Where

- k_{ax} factor, taking into account the angle α between screw axis and grain direction in accordance with A.2.3.1,
- $f_{ax,d}$ design value of the axial withdrawal parameter of the threaded part of the screw [N/mm²],
- d outer thread diameter of the screw [mm],
- l_{ef} penetration length of the threaded part of the screw in the rafter [mm], 40 mm $\leq l_{ef} \leq$ 100 mm,
- ρ_k characteristic density of the wood-based member [kg/m³], for LVL $\rho_k \leq$ 500 kg/m³,
- α angle α between screw axis and grain direction, 15° $\leq \alpha \leq$ 90°,
- $f_{head,d}$ design value of the head pull-through parameter of the screw [N/mm²],
- d_h head diameter of the screw [mm],
- $f_{tens,k}$ characteristic tensile strength of the screw in accordance with Annex 2 [N],
- γ_{M2} partial factor in accordance with EN 1993-1-1¹⁴,
- k_1 min {1; 220/ t_{HI} },
- k_2 min {1; $\sigma_{10\%}/0.12$ },
- t_{HI} thickness of the thermal insulation material [mm],
- $\sigma_{10\%}$ compressive stress of the thermal insulation material under 10 % deformation [N/mm²].

If equation (3.10) is fulfilled, the deflection of the counter battens does not need to be considered when designing the load-carrying capacity of the screws.

¹⁴ EN 1993-1-1:2005/AC:2009 Eurocode 3: Design of steel structures – Part 1-1: General rules and rules for buildings +A1:2014

BORGH TAC VS-Schroeven and TAC VS-Dakschroeven	Annex 3
Fastening of thermal insulation material on top of rafters	

diameter 8,0

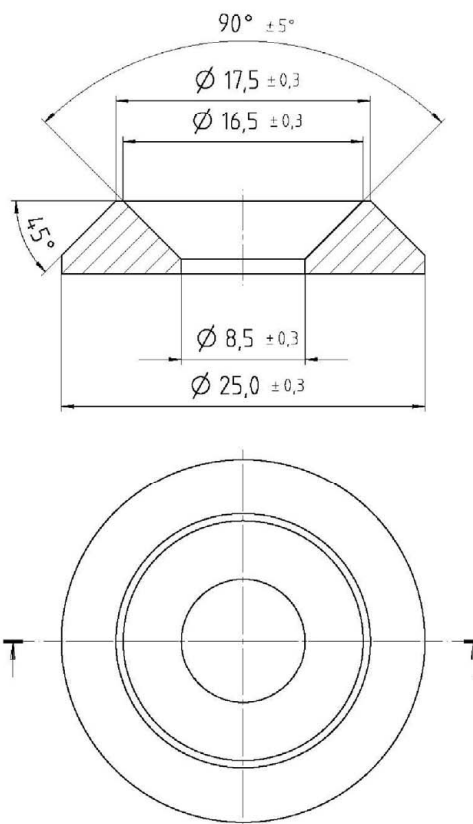

diameter 10,0

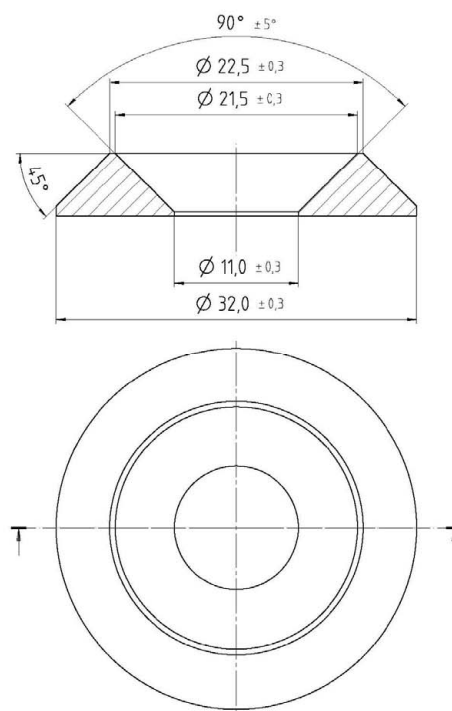

BORGH TAC VS-Schroeven and TAC VS-Dakschroeven

Washers for BORGH TAC VS-Schroeven (flat head)

Annex 4.1

Flat head diameter 8,0

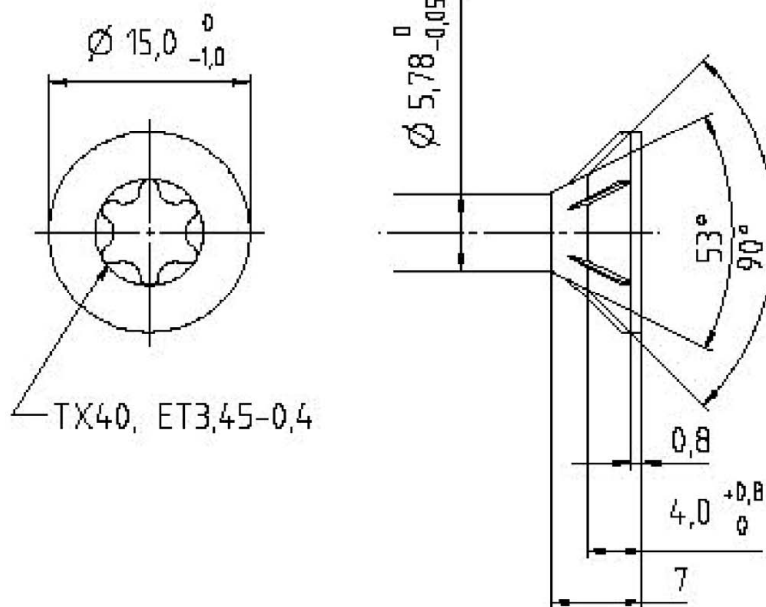

Flat head diameter 10,0

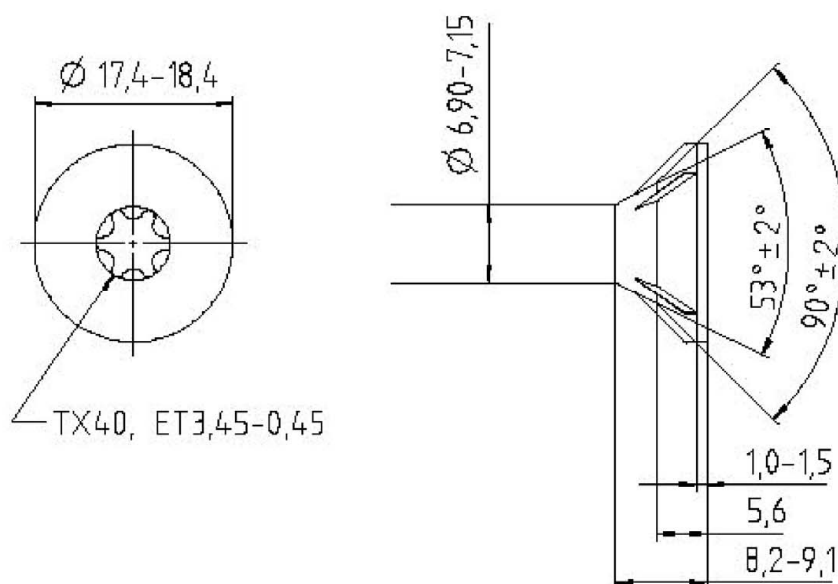

BORGH TAC VS-Schroeven and TAC VS-Dakschroeven

BORGH TAC VS-Schroeven (flat head)

Annex 4.2

Wafer head for diameter 8,0

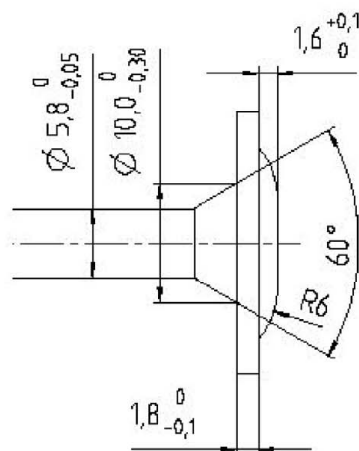
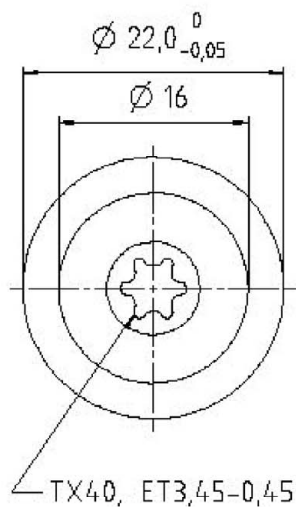

Wafer head for diameter 10,0

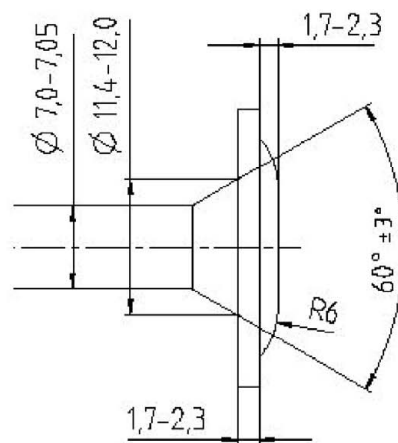
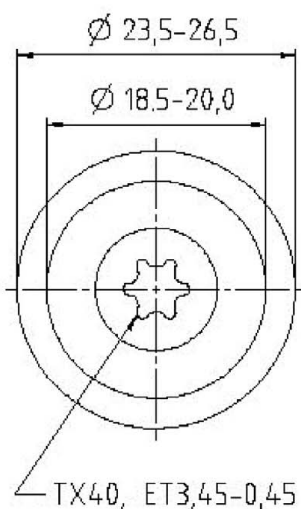

BORGH TAC VS-Schroeven and TAC VS-Dakschroeven

BORGH TAC VS-Dakschroeven (wafer head)

Annex 4.3

Wafer head for diameter 8,0

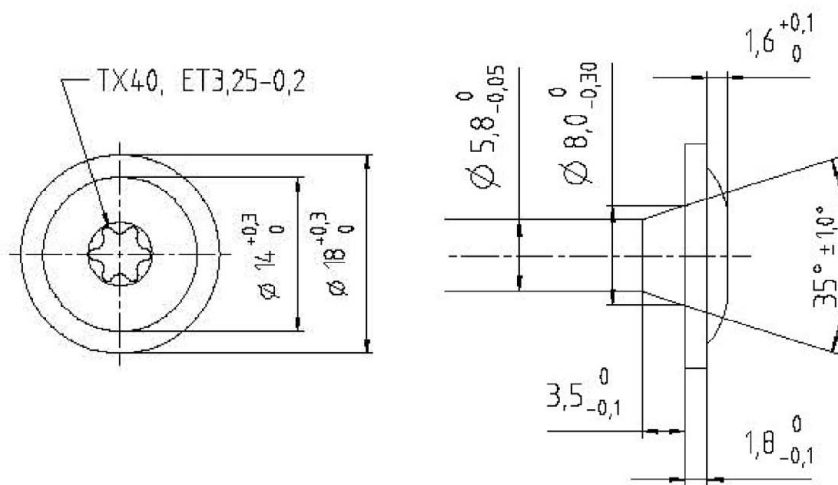

Electronic copy of the ETA by DIBt: ETA-22/0887

BORGH TAC VS-Schroeven and TAC VS-Dakschroeven

BORGH TAC VS-Dakschroeven (wafer head)

Annex 4.4

**Flat head, normal thread and
1-cut point diameter 8,0**

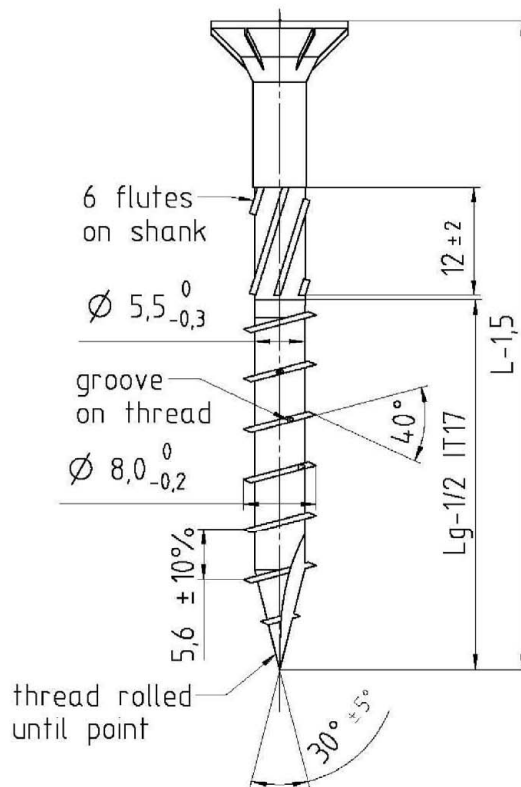

L	Lg
80	52
100	60
120	80
140	80
160	80/90
180	80/100
200	80/100
220	80/100
240	80/100
260	80/100
280	80/100
300	80/100
320	80/100
340	80/100
360	80/100
380	80/100
400	80/100

**Flat head, normal thread and
1-cut point diameter 10,0**

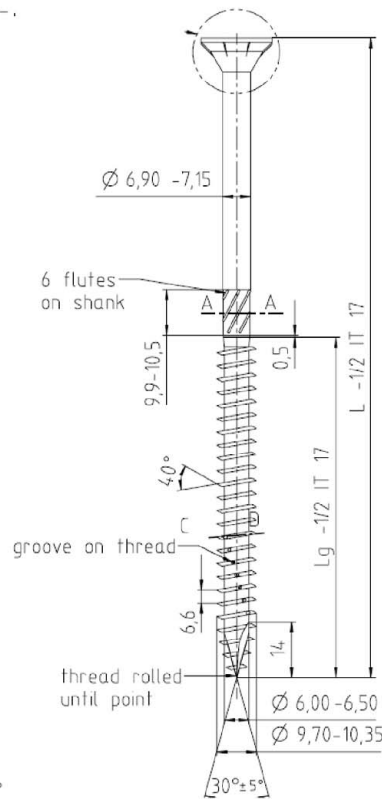

L	Lg
80	48
90	54
100	60
120	80
140	80
160	80/90
180	80/100
200	80/100
220	80/100
240	80/100
260	80/100
280	80/100
300	80/100
320	80/100
340	80/100
360	80/100
380	80/100
400	80/100

BORGH TAC VS-Schroeven and TAC VS-Dakschroeven

BORGH TAC VS-Schroeven (flat head screw) with normal thread

Annex 4.5

**Flat head, hilo thread and
4-cut point diameter 8,0**

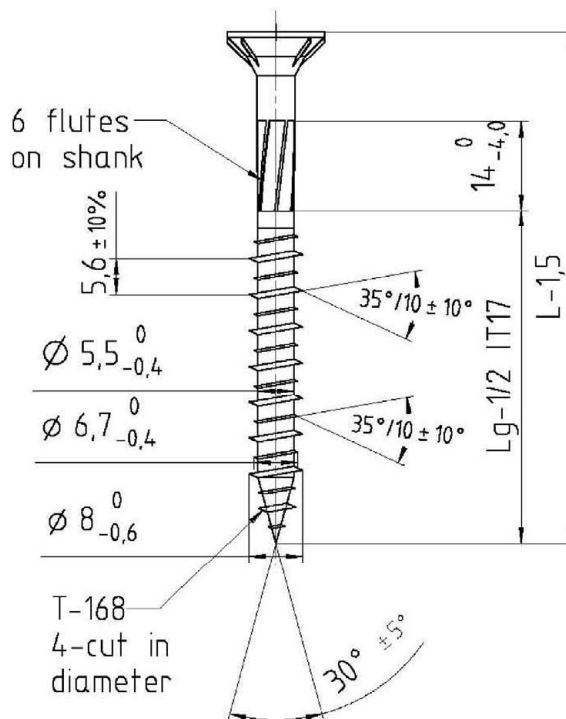

L	Lg
80	52
100	60
120	80
140	80
160	80/90
180	80/100
200	80/100
220	80/100
240	80/100
260	80/100
280	80/100
300	80/100
320	80/100
340	80/100
360	80/100
380	80/100
400	80/100

**Flat head, hilo thread and
4-cut point diameter 10,0**

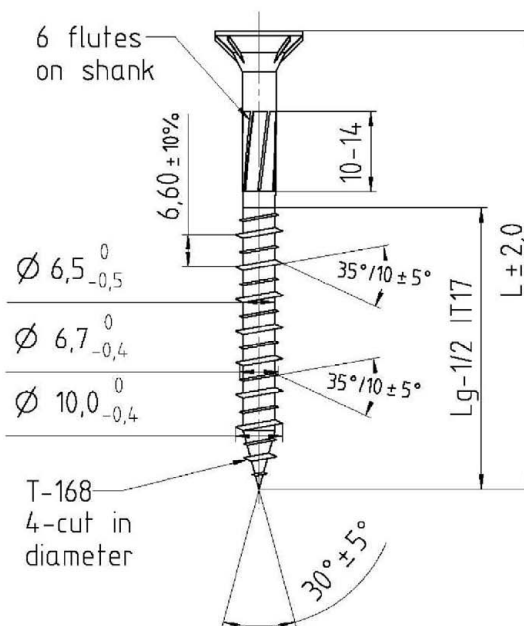

L	Lg
80	52
100	60
120	80
140	80
160	80/100
180	80/100
200	80/100
220	80/100
240	80/100
260	80/100
280	80/100
300	80/100
320	80/100
340	80/100
360	80/100
380	80/100
400	80/100

BORGH TAC VS-Schroeven and TAC VS-Dakschroeven

BORGH TAC VS-Schroeven (flat head screw) with hilo thread

Annex 4.6

**Wafer head,
normal thread and
1-cut point
diameter 6,0**

TX30, ET 2,5-3,0

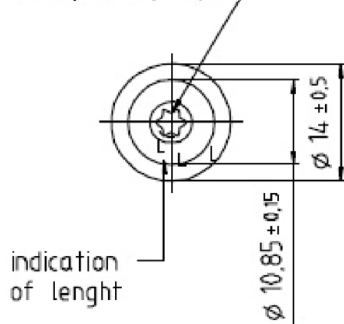

L	Lg
30	24
40	34
50	44
60	40
70	40
80	48
90	54
100	70
110	70
120	70
130	70
140	70
160	70
180	70
200	70
220	70
240	70
260	70
280	70
300	70

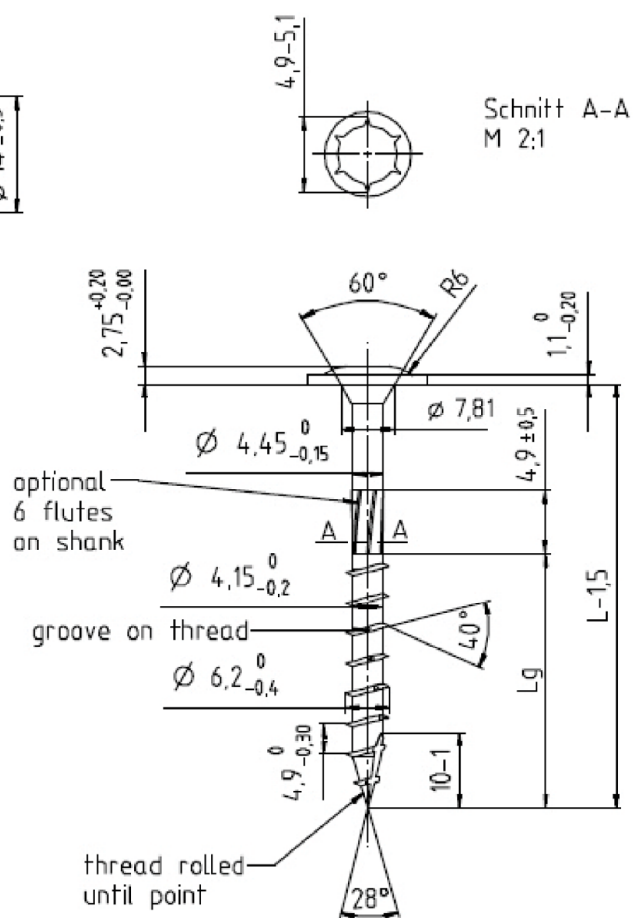

Schnitt A-A
M 2:1

BORGH TAC VS-Schroeven and TAC VS-Dakschroeven

BORGH TAC VS-Dakschroeven (wafer head screw) with normal thread

Annex 4.7

English translation prepared by DIBt

Wafer head, full thread and 1-cut point diameter 8,0

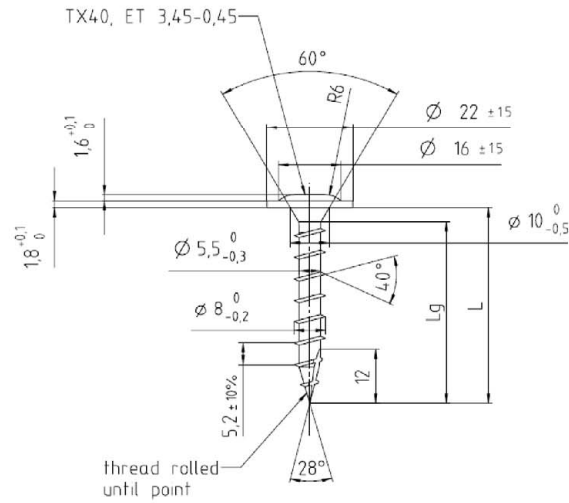

Wafer head, normal thread and 1-cut point diameter 8,0

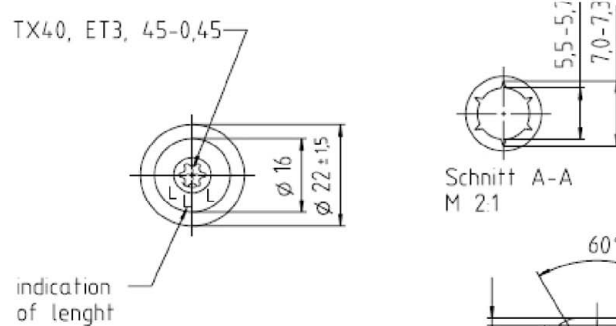

indication of length

L	Lg
40	33
50	43
60	53
80	48
100	60
120	80
140	80
160	80/90
180	80/100
200	80/100
220	80/100
240	80/100
260	80/100
280	80/100
300	80/100
320	80/100
340	80/100
360	80/100
380	80/100
400	80/100

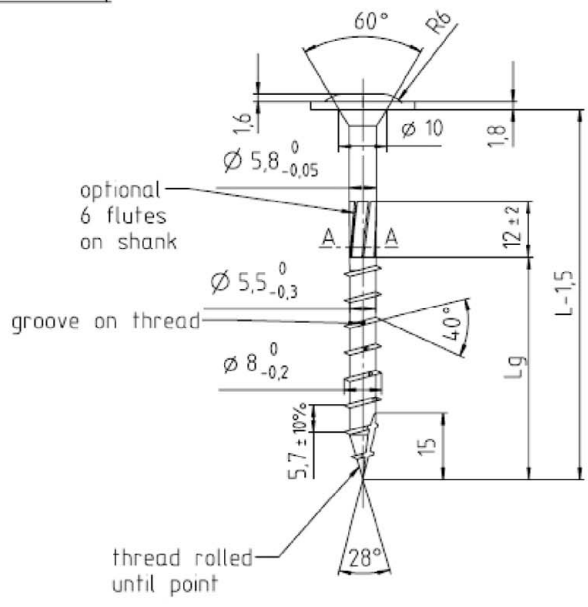

BORGH TAC VS-Schroeven and TAC VS-Dakschroeven

BORGH TAC VS-Dakschroeven (wafer head) with normal thread

Annex 4.8

**Wafer head, normal thread and
1-cut point diameter 10,0**

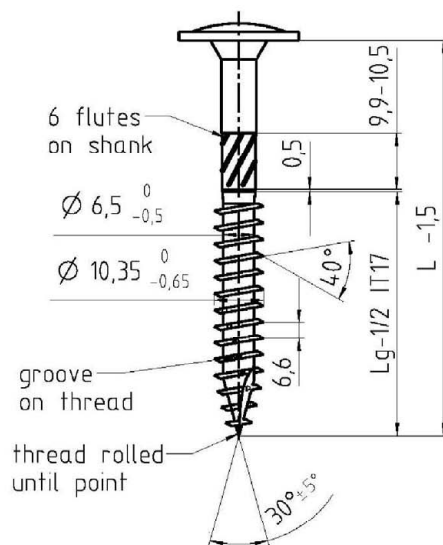

L	Lg
80	48
90	54
100	60
120	80
140	80
160	80/90
180	80/100
200	80/100
220	80/100
240	80/100
260	80/100
280	80/100
300	80/100
320	80/100
340	80/100
360	80/100
380	80/100
400	80/100

BORGH TAC VS-Schroeven and TAC VS-Dakschroeven

BORGH TAC VS-Dakschroeven (wafer head) with normal thread

Annex 4.9

English translation prepared by DIBt

Wafer head, hilo thread and 4-cut point diameter 8,0

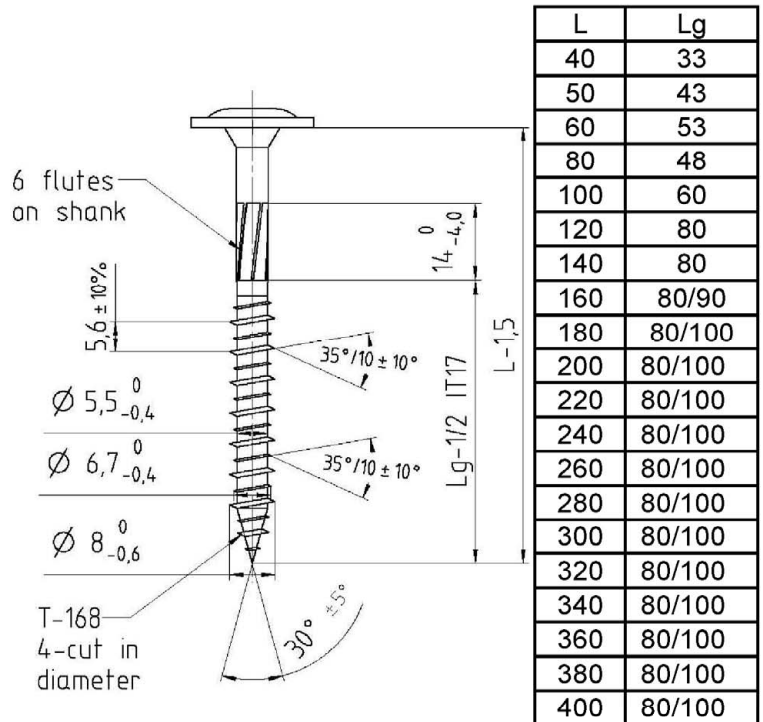

Wafer head, hilo thread and 4-cut point diameter 10,0

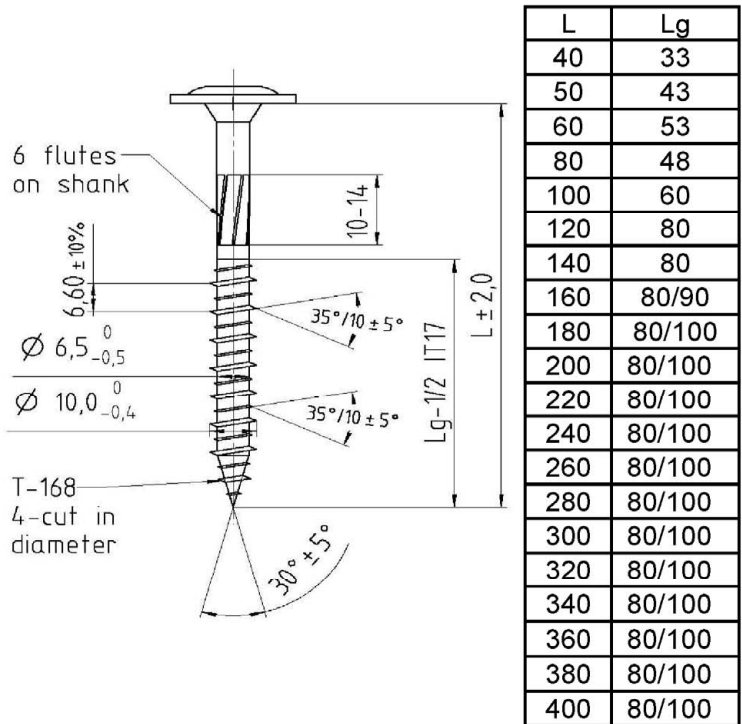

BORGH TAC VS-Schroeven and TAC VS-Dakschroeven

BORGH TAC VS-Dakschroeven (wafer head) with hilo thread

Annex 4.10

**Flat head, normal
thread and
1-cut point
diameter
3,5 – 6,0**

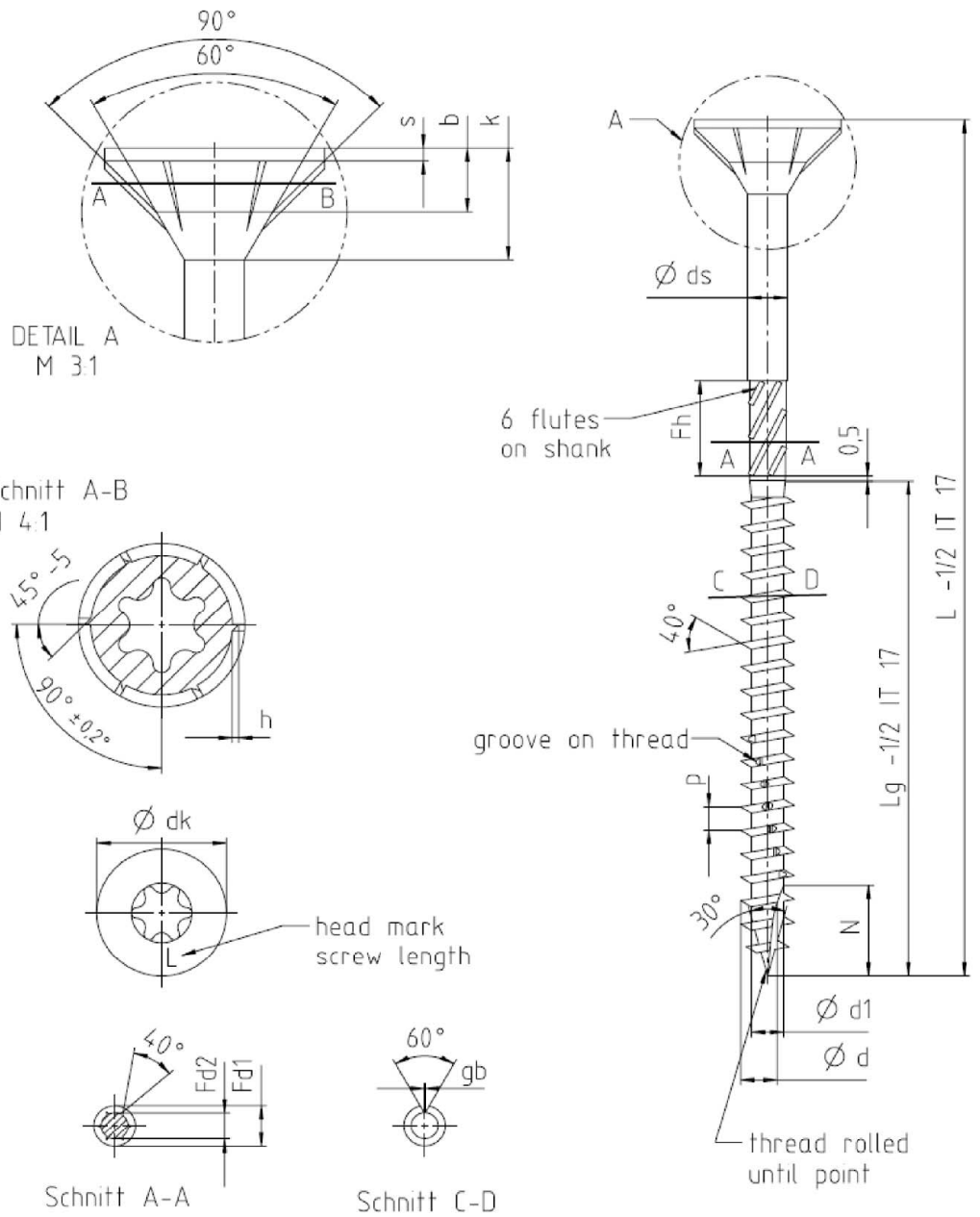

BORGH TAC VS-Schroeven and TAC VS-Dakschroeven

BORGH TAC VS-Schroeven (flat head) with normal thread

Annex 4.11

**Flat head, normal thread and
1-cut point diameter
3,5 – 6,0**

Nominal size		Ø 3,5	Ø 4,0	Ø 4,5	Ø 5,0	Ø 6,0
d	min	3,30	3,75	4,25	4,70	5,75
	max	3,70	4,10	4,60	5,15	6,20
d₁	min	2,00	2,35	2,60	3,00	3,80
	max	2,25	2,65	2,80	3,45	4,20
d_k	min	6,60	7,50	8,50	9,50	11,50
	max	7,00	8,00	9,00	10,00	12,00
k	min	3,00	3,45	4,15	4,50	5,40
	max	3,30	3,75	4,65	5,00	5,95
b	min	1,45	1,55	1,90	2,00	2,20
	max	1,75	1,85	2,20	2,30	2,50
h	min	0,20	0,25	0,30	0,35	0,40
	max	0,40	0,45	0,50	0,55	0,60
s	min	0,35	0,45	0,70	0,70	1,10
	max	0,65	0,70	1,00	1,10	1,35
N		6,0-7,0	7,0-8,0	8,0-9,0	9,0-10	10,0-12,0
hs	min					
	max					
Ls						
F_h	~	3,8-4,0	4,8-5,0	6,8-7,0	7,9 - 8,5	9,9-10,5
d_s	min	2,20	2,60	2,80	3,60	4,30
	max	2,40	2,80	3,10	3,80	4,50
F_{d1}		2,60 - 2,80	2,80 - 3,05	3,30 - 3,50	3,80- 4,00	4,50 - 5,00
F_{d2}		2,05-2,25	2,50-2,80	2,65 - 2,80	3,15 - 3,30	4,15 - 4,30
g_b		0,2	0,2	0,2	0,20	0,20
P	± 10%	2,24	2,52	2,80	3,10	4,90
TX		20	20	20/25	25/30	30
ET	min	1,65	2,00	2,20	2,30	2,60
	max	1,80	2,15	2,30	2,40	3,05

Diameter		Ø 3,5	Ø 4,0	Ø 4,5	Ø 5,0	Ø 6,0
Length		Thread length lg				
L max.	L min.					
20	19,00	17				
25	24,00	22	22			
30	28,95	18	18	18		
35	34,95	21	21	21	21	
40	38,75	24	24	24	24	24
45	43,75	27	27	27	27	27
50	48,75	30	30	30	30	30
60	58,50		36	36	36	36
70	68,50		42	42	42	42
80	78,50		48	48	48	48
90	88,25				54	54
100	98,25				60	60
110	108,25				70	70
120	118,25				70	70
130	128,00					70
140	138,00					70
150	148,00					70
160	158,00					70
180	178,00					70
200	197,70					70
240	237,70					70
260	257,40					70
280	277,40					70
300	297,40					70

BORGH TAC VS-Schroeven and TAC VS-Dakschroeven

BORGH TAC VS-Schroeven (flat head) with normal thread

Annex 4.12

4-cut point for diameter 8,0

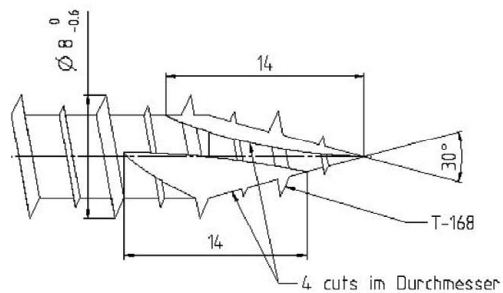

4-cut point for diameter 10,0

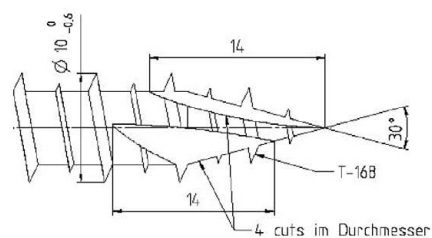

1-cut point for diameter 8,0

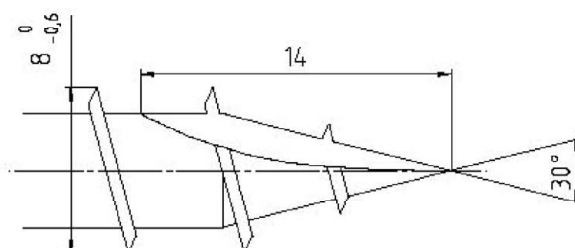

1-cut point for diameter 10,0

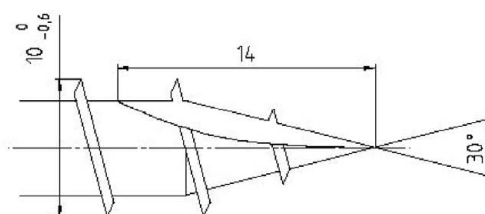

BORGH TAC VS-Schroeven and TAC VS-Dakschroeven

Screw points

Annex 4.13