

Approval body for construction products  
and types of construction

Bautechnisches Prüfamt

An institution established by the Federal and  
Laender Governments



## European Technical Assessment

ETA-23/0358  
of 4 December 2023

English translation prepared by DIBt - Original version in German language

### General Part

Technical Assessment Body issuing the  
European Technical Assessment:

Deutsches Institut für Bautechnik

Trade name of the construction product

BEWI IFC System

Product family  
to which the construction product belongs

Product area code: 34  
Non load-bearing permanent shuttering kits/systems  
based on hollow blocks or panels of insulating materials  
and sometimes concrete

Manufacturer

UAB Baltijos polistirenas  
S. Lozoraicio g. 15 A, Garliava  
KAUNO RAJ.  
LITAUEN

Manufacturing plant

UAB Baltijos polistirenas  
S. Lozoraicio g. 15 A, Garliava  
KAUNO RAJ.  
LITAUEN

This European Technical Assessment  
contains

22 pages including 2 annexes which form an integral part  
of this assessment

This European Technical Assessment is  
issued in accordance with Regulation (EU)  
No 305/2011, on the basis of

340309-00-0305

The European Technical Assessment is issued by the Technical Assessment Body in its official language. Translations of this European Technical Assessment in other languages shall fully correspond to the original issued document and shall be identified as such.

Communication of this European Technical Assessment, including transmission by electronic means, shall be in full. However, partial reproduction may only be made with the written consent of the issuing Technical Assessment Body. Any partial reproduction shall be identified as such.

This European Technical Assessment may be withdrawn by the issuing Technical Assessment Body, in particular pursuant to information by the Commission in accordance with Article 25(3) of Regulation (EU) No 305/2011.

## Specific part

### 1 Technical description of the product

#### 1.1 Definition of the construction product

The shuttering system "BEWI" is a non-load-bearing permanent shuttering kit consisting of shuttering elements and accessory parts (see Annexes A3 to A10) applicable as formwork for plain and reinforced concrete walls cast in-situ.

The shuttering elements are generally used as non-loadbearing formwork for external as well as internal load-bearing walls.

Finishes are not part of the "BEWI" shuttering system.

The structural evaluation of the concrete core is not covered by this document.

#### 1.2 Shuttering elements

There are two different versions of the BEWI shuttering kit:

- Standard kit and
- PLUS kit.

In both versions the shuttering leaves are made of high density, expanded polystyrene (EPS) according to EN 13163:2012 + A2:2016.

The shuttering elements are interlocked and build up horizontally and vertically into a tight and rigid formwork. The blocks are dry laid in staggered vertical joints (brick bond). The wall is formed by filling of the shuttering elements with concrete. The formwork is used in conjunction with concrete of classes in the range from C16/20 to C50/60 (according to EN 206:2013 + A1:2016) erecting plain concrete walls or in conjunction with concrete of classes in the range from C20/25 to C50/60 (according to EN 206:2013 + A1:2016) building reinforced concrete walls.

The top and the bottom surfaces of each EPS shuttering leaf incorporate an interlocking arrangement to form a tight joint (see Annex A3 to A9).

The vertical surfaces at the outside of the shuttering leaf are generally smooth with element-high slight vertical grooves. At the surfaces forming the face of the wall these grooves are at 50 mm centres. At the surfaces forming the vertical joint between two blocks the surface allows for a tongue and groove connection forming a tight but unsealed joint.

The shuttering leaf surface facing the concrete is structured by 20 mm wide grooves forming a dovetail joint. The dovetails are centred at 50 mm, three in a row.

The system can be used to construct straight walls with 90 degree angles.

English translation prepared by DIBt

### 1.2.1 Standard kit

The Standard kit (Annex A3 – A5) is characterised by internal walls being monolithically connected with the shuttering leaves. The internal walls are also made of EPS. The solid block cannot be disassembled.

Table 1: elements Standard Kit (Annex A3 - A5)

standard kit					
elements	dimensions l x h x t	thickness			
		inner leaf	concrete core	outer leaf	wall
		[mm]	[mm]	[mm]	[mm]
<b>MC</b>		<b>main wall blocks</b>			
<b>ML</b>		<b>lintel blocks</b>			
MC/ML 50	1250x300x250	50	150	50	250
MC/ML 100	1250x300x300	50	150	100	300
MC/ML 150	1250x300x350	50	150	150	350
MC/ML 200	1250x300x400	50	150	200	400
<b>MP</b>		<b>ceiling block</b>			
MP 50	1250x300x250	-	115+45	45	250
MP 100	1250x300x300	-	115+45	95	300
MP 150	1250x300x350	-	115+45	145	350
MP 200	1250x300x400	-	115+45	195	400

The finished wall, being built with the standard kit, may be 250, 300, 350 or 400mm thick, while the thickness of the concrete core remains at 150 mm. One shuttering leaf is 50 mm, the thickness of the second shuttering leaf determines the final wall thickness. It can be 50, 100, 150 or 200 mm thick. Each Block is 300 mm high and 1250 mm long.

Lintel Blocks and Ceiling Support Blocks are part of the BEWI Standard Shuttering kit, both types of elements are 300 mm high and 1250 mm long.

The dimensions of the ceiling support block differ from the main block allowing for a continuous transition of reinforcement and concrete into the slab.

The shuttering leaf surface facing the concrete is structured by 20 mm wide grooves forming a dovetail joint. The dovetails are centred at 50 mm, three in a row. At 250 mm centres the internal walls are placed (see Annex A3).

Wall junctions and corners are executed with butt joints, an according sketch is shown in figures 1 and 2, Annex B1. At the intersection of the walls, in each layer the shutter leaf gets removed along the length of the concrete core of the perpendicular wall. Hence allowing for unobstructed concrete flow.

The concrete infill structural pattern of the standard kit resembles a grid.

### 1.2.2 PLUS kit

The blocks of the PLUS kit (Annex A8 and A9) comprise of the two EPS shuttering leaves being connected by plastic spacers according to annex A1. The spacers are moulded from high density plastic (polyethylene, HDPE spacer). When moulding the PLUS Blocks spacer are already put in place. PLUS blocks are not assembled on site.

Each shuttering leaf is one-layered, the minimum thickness is 50mm. The second shuttering leaf can be 50, 150, or 250 mm thick. The concrete core is always 150 mm thick, creating walls with an overall thickness of 250, 350 or 450 m.

Each PLUS Block is 300 mm high. There are straight Main Wall Blocks with a length of 1000 mm and Corner Wall Blocks PLUS with edge lengths of 800/900/1000 mm and 400/500/600 mm. The Corner Blocks are available as left and right corner.

Wall junctions are executed with butt joints (see figures 1 and 2 in Annex B1). In each layer the shutter leaf gets removed at the joint allowing for unobstructed concrete flow.

The shuttering leaf surface facing the concrete is structured by 20 mm wide grooves forming a dovetail joint. The dovetails are centred at 50 mm, three in a row. At 200 mm centres the HDPE -spacers are placed, at the spacer location there are no groves (see Annex A8 and A9).

Steel reinforcement can be fixed directly to the HDPE spacer web.

The concrete infill structural pattern of the PLUS kit resembles a continuous wall.

Table 2: elements PLUS Kit (Annex A8 and A9)

PLUS kit					
elements	dimensions l x h x t [mm]	thickness			
		inner leaf	concrete core	outer leaf	wall
		[mm]	[mm]	[mm]	[mm]
<b>MC PLUS __</b>		<b>main wall block PLUS</b>			
MC 50 PLUS	1000x300x250	50	150	50	250
MC 150 PLUS	1000x300x350	50	150	150	350
MC 250 PLUS	1000x300x450	50	150	250	450
<b>MC PLUS __ K</b>		<b>corner wall block PLUS</b>			
MC 50 PLUS K	800x300x400	50	150	50	250
MC 150 PLUS K	900x300x500	50	150	150	350
MC 250 PLUS K	1000x300x600	50	150	250	450

### 1.3 Accessory parts

#### 1.3.1 BEWI Plugs, Types OB and OH (Annex A6)

The BEWI Plugs are to be used with the Standard Blocks extending the internal walls to block height, creating an internal barrier for the concrete flow.

#### 1.3.2 BEWI Insert Element OC (Annex A7)

The BEWI Insert Elements are used with Standard Blocks and PLUS Blocks for closing off the cross section full height. It is used for building corners or large-scale openings like doors or windows.

#### 1.3.3 BEWI Additional Element BEWI PLUS (Annex A7)

The additional element is used for MC 250 PLUS walls, since there are no specific lintel or ceiling support blocks. The additional Element BEWI PLUS is used for extending the external leaf of the ML 200 or MP 200 block.

English translation prepared by DIBt

#### 1.4 EPS Material

For the shuttering leaves, expanded polystyrene products according to EN 13163:2012 + A2:2016 with a declared value for the thermal conductivity of  $\lambda_D = 0,031 \text{ W/(m}\cdot\text{K)}$  and the following designation code is used:

EPS-EN 13163-L(2)-W(2)-T(1)-CS(10)150-BS250-TR280

## 2 Specification of the intended use in accordance with the applicable European Assessment Document

The kit is intended to be used for the construction of internal walls as well as external walls above or below ground which are load-bearing (structural) or non load-bearing (non structural), including those which are subjected to fire regulations.

When using this type of construction below ground a waterproofing according to applicable national rules shall be provided depending on whether non pressing water or pressing water is to be dealt with. The waterproofing shall be protected from mechanical damage by an impact resistant protective layer.

According to EOTA TR 034 the following use categories apply:

- Category IA 3: Product with no contact to indoor air.

The performance given in Section 3 are only valid if the shuttering elements are used in compliance with the specifications and conditions given in Annex A1.

The verification and assessment methods on which this European Technical Assessment is based lead to the assumption of a working life of the shuttering kit of at least 50 years. The indications given on the working life cannot be interpreted as a guarantee given by the manufacturer, but are to be regarded only as a means for choosing the right products in relation to the expected economically reasonable working life of the works.

## 3 Performance of the product and references to the methods used for its assessment

### 3.1 Mechanical resistance and stability (BWR 1)

Essential characteristic	Performance
Resulting structural pattern	
Standard Block	Grid type according to EAD 340309-00-0305, chapter 1.3.3
PLUS Block	Continuous type according to EAD 340309-00-0305, chapter 1.3.3
Efficiency of filling	see Annex B1
Possibility of steel reinforcement	see Annex B1

English translation prepared by DIBt

### 3.2 Safety in case of fire (BWR 2)

Essential characteristic	Performance
Reaction to fire	
EPS Blocks	Class E according to EN 13501-1:2018 With a density of 29 kg/m <sup>3</sup> ± 15 % (25-33 kg/m <sup>3</sup> )
HDPE-spacer	No performance accessed
Influence of the shuttering kit on the fire resistance	
Standard Block (grid type)	R30 according to EAD 340309-00-0305, Annex A Table A2
PLUS Block (continuous type)	REI120 according to EAD 340309-00-0305, Annex A Table A1

### 3.3 Hygiene, health and the environment (BWR 3)

Essential characteristic	Performance
Content, emission and/or release of dangerous substances	
Substances, classified as Carc. 1A/1B <sup>a)</sup>	None of these raw materials are actively used in the manufacture of the construction product. <sup>b) c)</sup>
Substances, classified as Muta. 1A/1B <sup>a)</sup>	
Substances, classified as Acute Tox. 1, 2, 3; Repr. 1A/1B; STOT SE 1 and STOT RE 1 <sup>a)</sup>	
Use scenarios regarding BWR 3:	
IA 3	Declared release scenario
S/W2; S/W3	No performance accessed
Water vapour permeability of the EPS leaves	μ = 70-120 according to EN 12086:2013
Water absorption of the EPS leaves	<4 % according to EN ISO 16535:2019
Water tightness	No performance accessed (finishes are not part of the shuttering kit)

<sup>a)</sup> In accordance with Regulation (EC) No 1272/2008

<sup>b)</sup> Active use is the targeted use of substances to achieve specific product properties. Substances that are present as impurities and/or as a secondary component in the product are therefore not to be regarded as "actively used".

<sup>c)</sup> Assessment based on the detailed manufacturers' statements on dangerous substances.

### 3.4 Safety and accessibility in use (BWR 4)

Essential characteristic	Performance
Bond strength	see Annex B2
Standard Block	> 450 kPa according to EN 1607:2013
PLUS Block	> 420 kPa according to EN 1607:2013
Resistance to impact load	no performance assessed
Resistance to filling pressure	see Annex B2
Safety to personal injuries	The shuttering elements do not have sharp or cutting edges. Due to the soft surfaces of the shuttering leaves, there is no risk of abrasion or of cutting to people.

### 3.5 Protection against noise (BWR 5)

Essential characteristic	Performance
Airborne sound insulation	no performance assessed
Sound absorption	no performance assessed

### 3.6 Energy economy and heat retention (BWR 6)

Essential characteristic	Performance
Thermal resistance of the wall (EPS shuttering elements filled with concrete)	See table 1 in Annex B3
Thermal inertia	no performance assessed

### 3.7 Aspects of durability

Built-in finishes are not part of the assessed shuttering kit.

Essential characteristic	Performance
Resistance to deterioration	no performance assessed

## 4 Assessment and verification of constancy of performance (AVCP) system applied, with reference to its legal base

In accordance with EAD No. 340309-00-0305, the applicable European legal act is Decision 98/279/EC as amended by Commission Decision 2001/596/EC of 8 January 2001.

The system to be applied is: 2+



**5 Technical details necessary for the implementation of the AVCP system, as provided for in the applicable EAD**

Technical details necessary for the implementation of the AVCP system are laid down in the control plan deposited with Deutsches Institut für Bautechnik.

Issued in Berlin on 4 December 2023 by Deutsches Institut für Bautechnik

Dr.-Ing. Lars Eckfeldt  
Head of Section

*beglaubigt:*  
Groth

**Installation / manufacturer's instructions**

**General**

The manufacturer shall ensure that the installation guide is known to those involved in planning and execution. The installation guide is deposited at DIBt and shall be present at every construction site.

After installation of the shuttering elements the site-mixed or ready mixed concrete is brought in and compacted.

In end use conditions concrete walls of grid type<sup>1</sup> (Standard kit) and continuous type<sup>1</sup> (PLUS kit) of plain or reinforced concrete according to EN 1992-1-1 or corresponding national rules will be formed.

In end use conditions the EPS-shuttering leaves are the main part of the thermal insulation of the walls.

**Reworking and finishes**

Walls of the type "BEWI" are to be protected by finishes. Finishes are not part of the kit and therefore not considered in this ETA.

Preferably for external surfaces the used rendering systems should meet the requirements of EAD 040083-00-0404. Execution of the rendering shall be performed according to applicable national rules.

**Fixing of objects**

Fixing of objects in the shuttering leaves is not possible, the part of fixings which is significant for the mechanical resistance shall be in the concrete. The influence of the fixing to the reduction of the thermal resistance has to be considered according to EN ISO 6946:2018.

<sup>1</sup> see EAD 340309-00-0305 chapter 1.3.3

BEWI IFC SystemBEWI IFC SystemShuttering kit "BEWI"	Annex A1
Installation	

<b>Standards and guidelines</b>			
<b>standards and guidelines</b>	<b>issue</b>	<b>title</b>	
EN 1992-1-1	2011-01 +A1:2015-03	Eurocode 2: Design of concrete structures – Part 1-1: General rules and rules for buildings;	
EN 13163	2012 + A2:2016	Thermal insulation products for buildings – Factory made expanded polystyrene (EPS) products – Specification	
EN 206	2013 + A1:2016	Concrete – specification, performance, production and conformity	
EN 13501-1:	2018	Fire classification of construction products and building elements - Part 1: Classification using data from reaction to fire tests	
EN 12086	2013	Thermal insulating products for building applications - Determination of water vapour transmission properties	
EN ISO 16535	2019	Thermal insulating products for building applications - Determination of long-term water absorption by immersion	
EN ISO 6946	2018-03	Building components and building elements - Thermal resistance and thermal transmittance - Calculation methods	
BEWI IFC SystemBEWI IFC SystemBEWI IFC SystemShuttering kit "BEWI"			Annex A2
List of standards and guidelines used			

### BEWI main wall block – MC50 / 100 / 150 / 200

Plan view

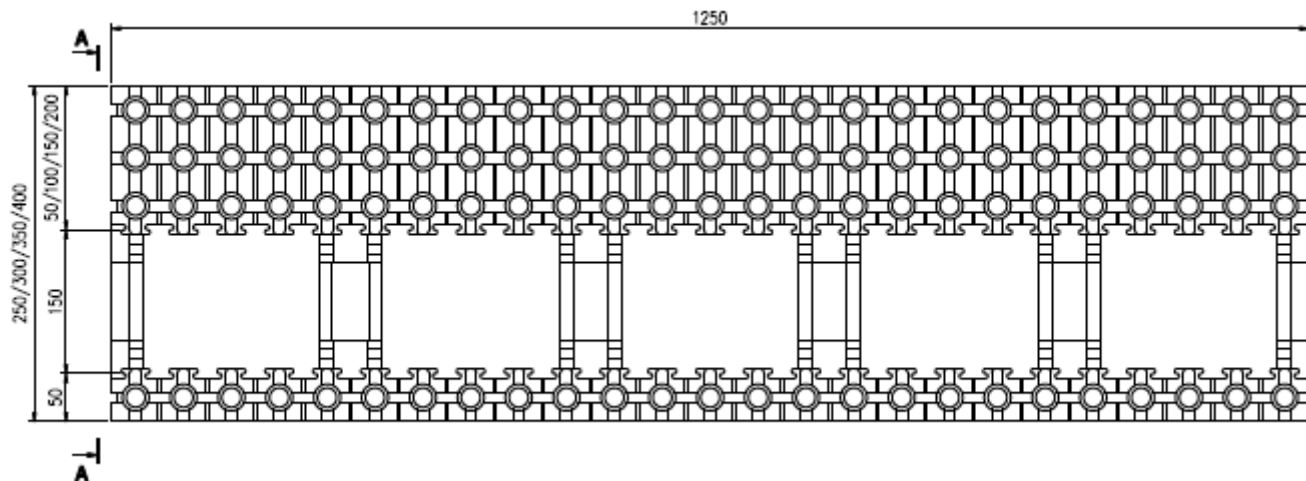

Cross Section A-A

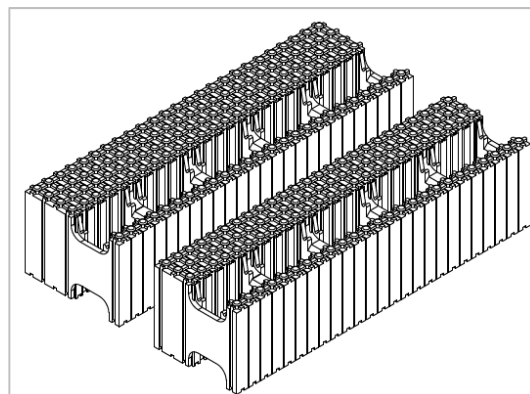
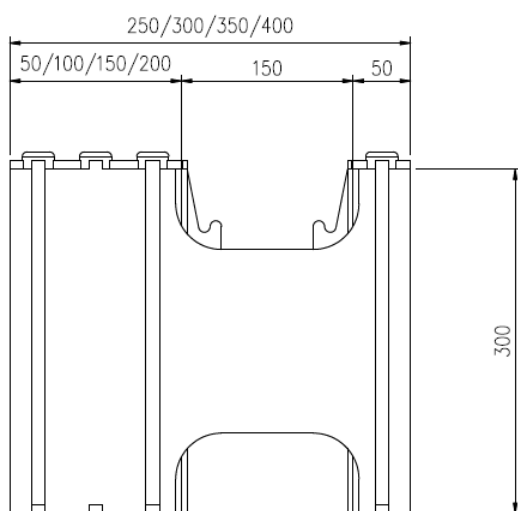

Sketches not to scale  
All dimensions in [mm]

elements	dimensions l x h x t [mm]	outer leaf t [mm]
MC 50	1250x300x250	50
MC 100	1250x300x300	100
MC 150	1250x300x350	150
MC 200	1250x300x400	200

Thickness inner leaf t = 50mm  
concrete core t = 150mm

BEWI IFC SystemBEWI IFC SystemShuttering kit "BEWI"

BEWI standard kit - main wall block – type MC  
t = 250/300/350/400mm

Annex A3

## BEWI lintel block – ML50 / 100 / 150 / 200

Plan view

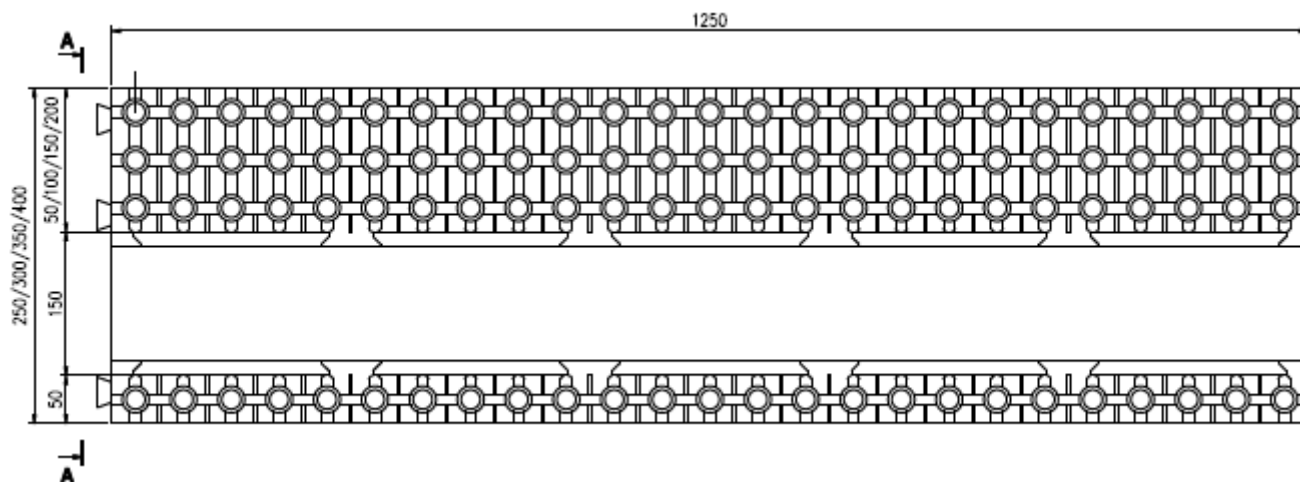

Cross Section A-A

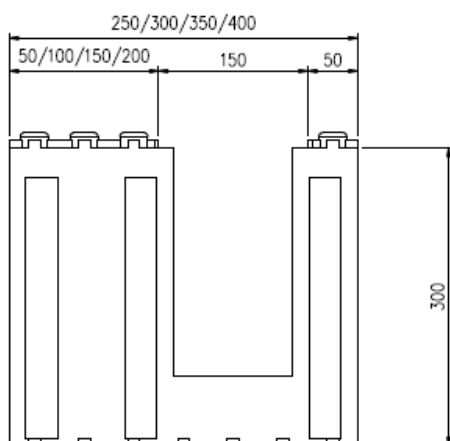

elements	dimensions l x h x t [mm]	outer leaf t [mm]
ML 50	1250x300x250	50
ML 100	1250x300x300	100
ML 150	1250x300x350	150
ML 200	1250x300x400	200
Thickness	inner leaf t = 50mm concrete core t = 150mm	

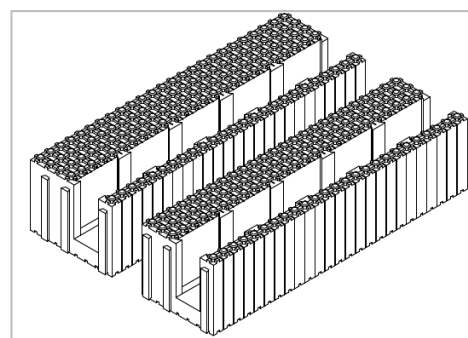

Sketches not to scale  
All dimensions in [mm]

BEWI IFC SystemBEWI IFC SystemShuttering kit "BEWI"

BEWI standard kit - lintel block – type ML  
t = 250/300/350/400mm

Annex A4

## BEWI ceiling support block – MP 50 / 100 / 150 / 200

Plan view

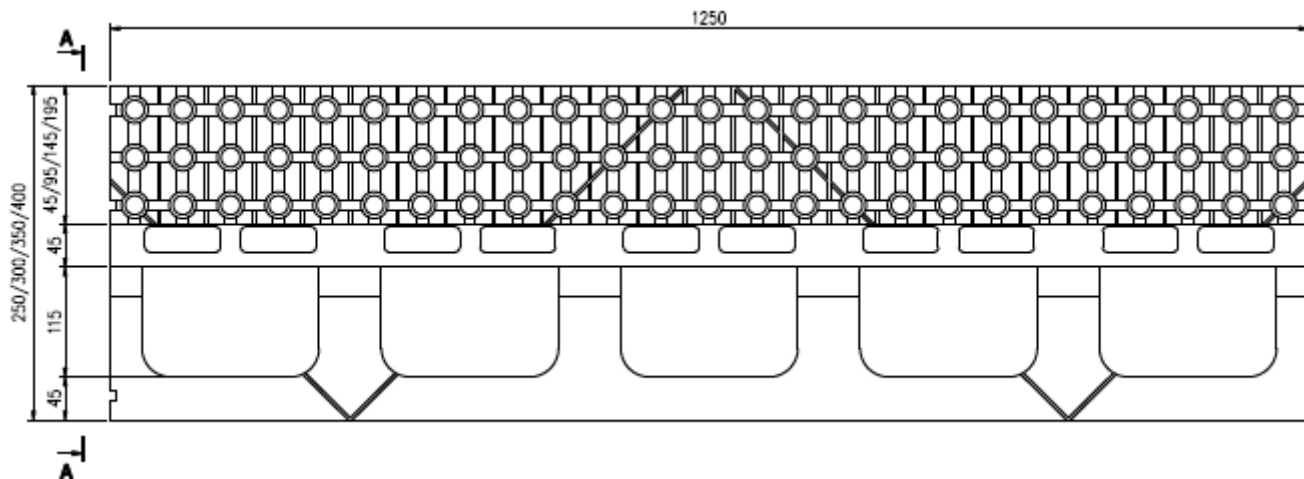

Cross Section A-A

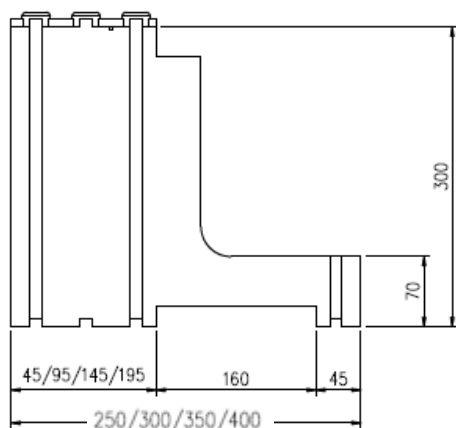

elements	dimensions l x h x t [mm]	outer leaf t [mm]
MP 50	1250x300x250	45
MP 100	1250x300x300	95
MP 150	1250x300x350	145
MP 200	1250x300x400	195

Constant dimensions

inner leaf	t = 45 mm
	h = 70mm
concrete core	t = 115 + 45 mm

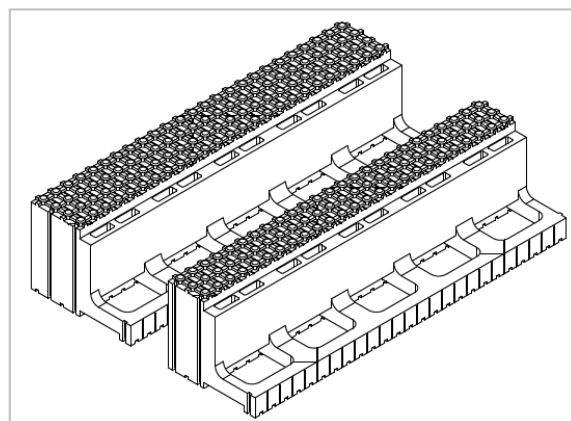

Sketches not to scale  
All dimensions in [mm]

BEWI IFC SystemBEWI IFC SystemBEWI IFC SystemShuttering kit "BEWI"

BEWI standard kit - ceiling support block – type MP  
t = 250/300/350/400mm

Annex A5

## BEWI plugs OB and OH

Type OB – cross section and plan view

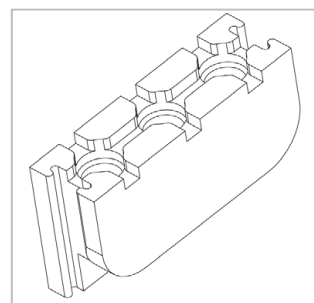
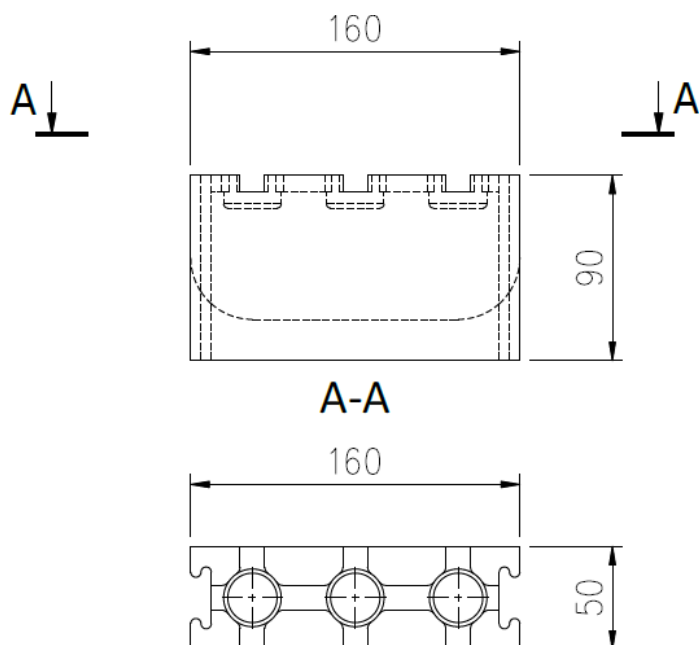

Type OH – cross section and plan view

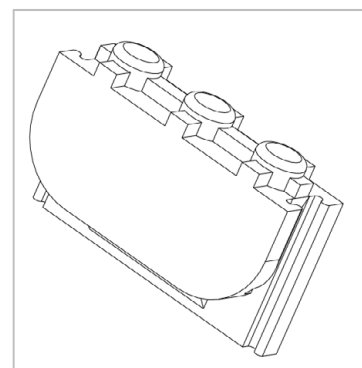
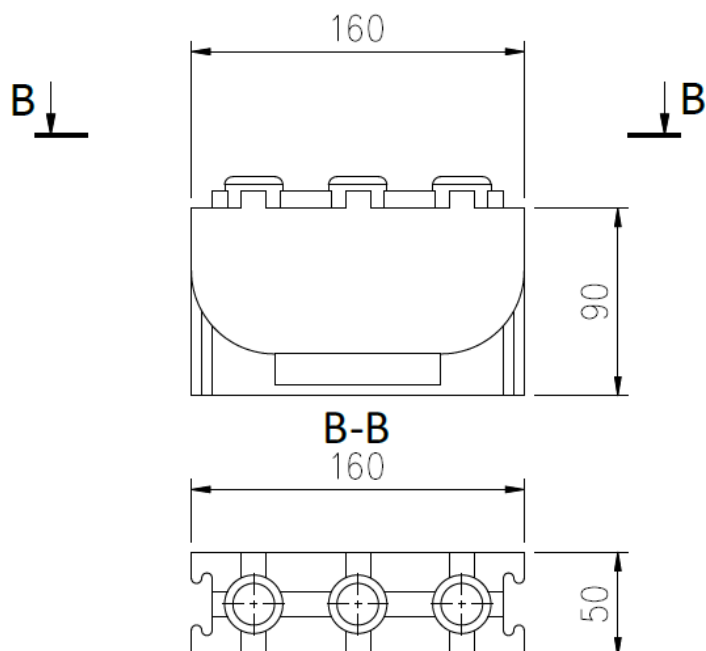

Sketches not to scale  
All dimensions in [mm]

BEWI IFC System BEWI IFC System BEWI IFC System Shuttering kit "BEWI"

BEWI plug – types OB, OH  
l/h/t = 160/90/50mm

Annex A6

### BEWI insert element - OC

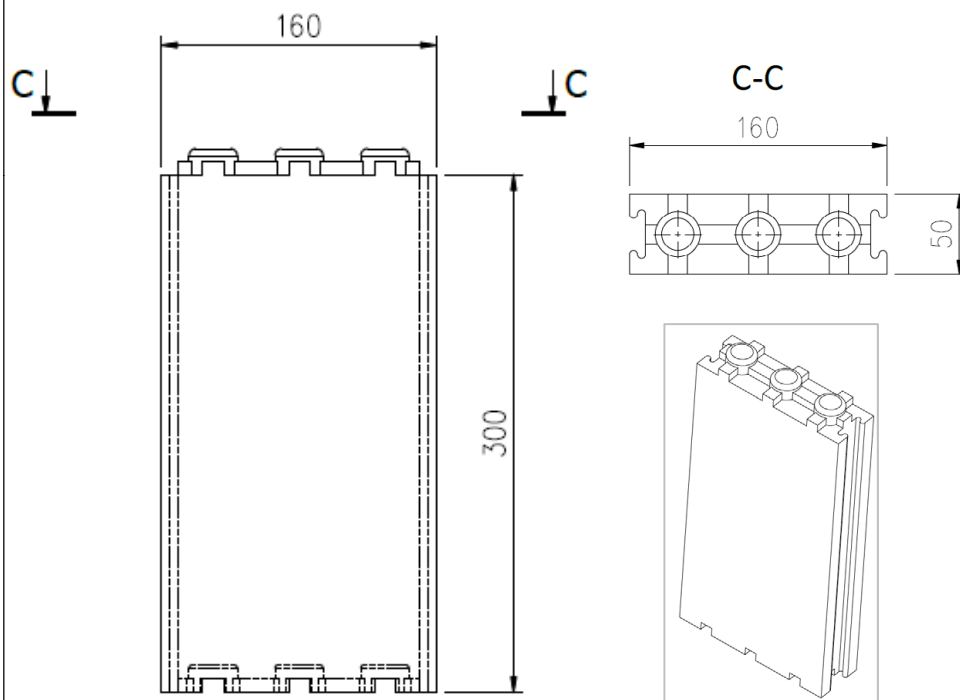

### BEWI additional element – BEWI PLUS

Plan view

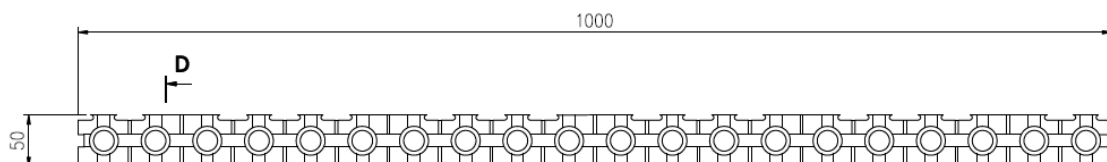

Cross section D-D

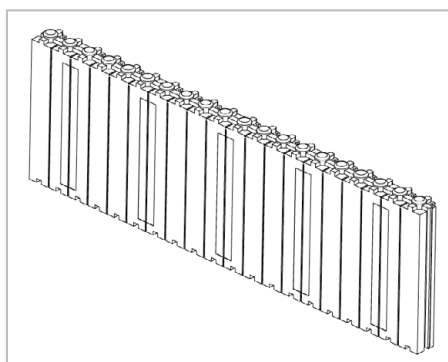
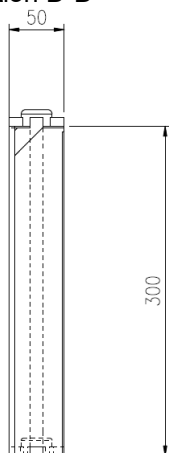

Sketches not to scale  
All dimensions in [mm]

BEWI IFC SystemBEWI IFC SystemShuttering kit "BEWI"

BEWI insert element OC, BEWI additional element

Annex A7



English translation prepared by DIBt

### BEWI main wall block PLUS – MC \_\_ Plus

Plan view

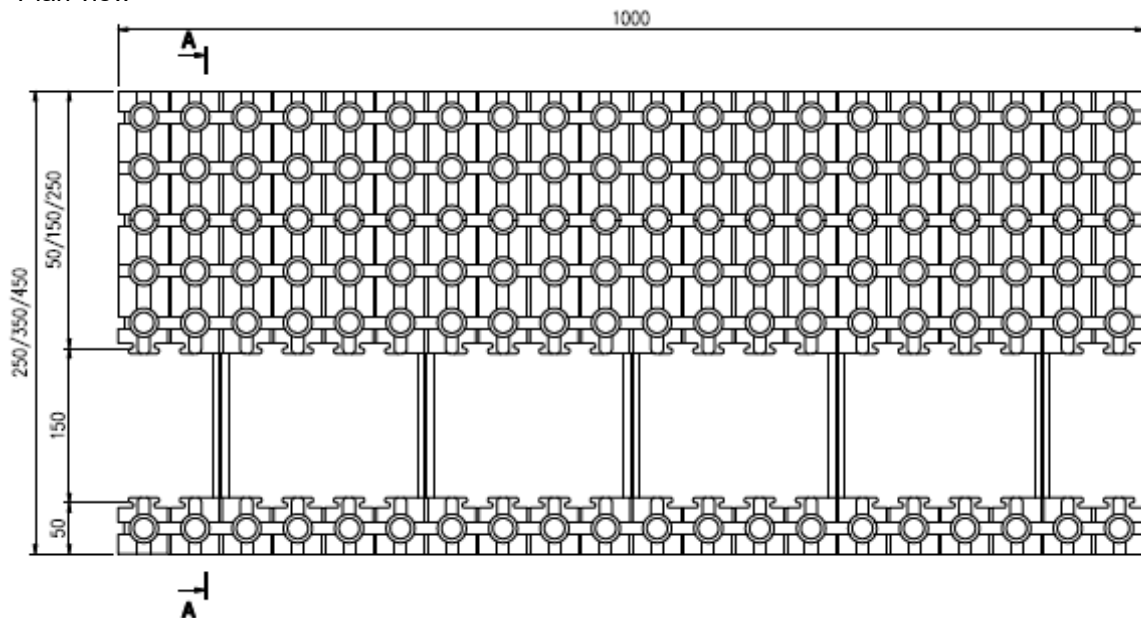

Cross Section A-A

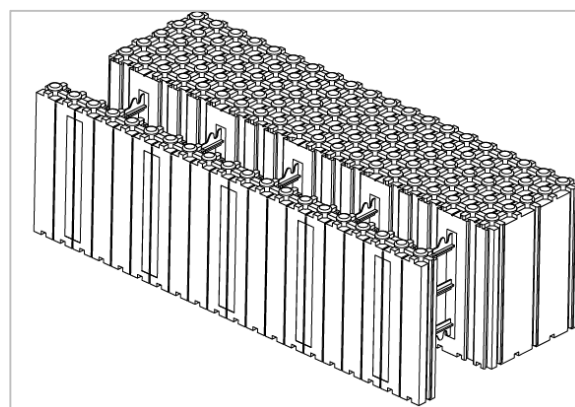
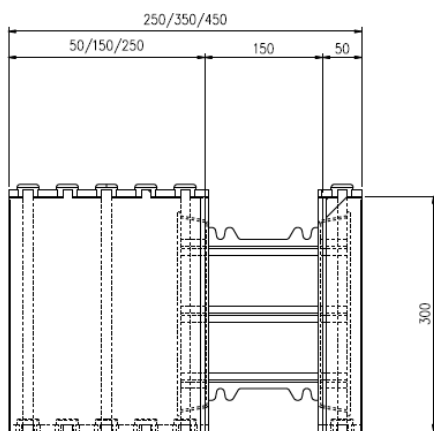

elements	dimensions l x h x t [mm]	outer leaf t [mm]
MC 50 PLUS	1000x300x250	50
MC 150 PLUS	1000x300x350	150
MC 250 PLUS	1000x300x450	250

Thickness	inner leaf	t = 50mm
	concrete core	t = 150mm

Sketches not to scale  
All dimensions in [mm]

BEWI IFC System BEWI IFC System Shuttering kit "BEWI"

BEWI PLUS kit - main wall block PLUS - MC \_\_ Plus  
t = 250/350/450mm

Annex A8

## BEWI corner wall block PLUS (left and right) – MC \_\_ Plus K

Plan view

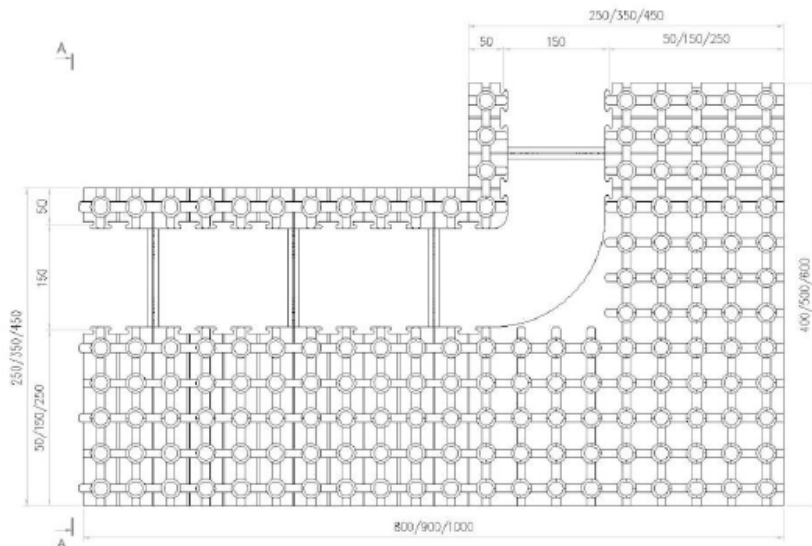

Cross Section A-A

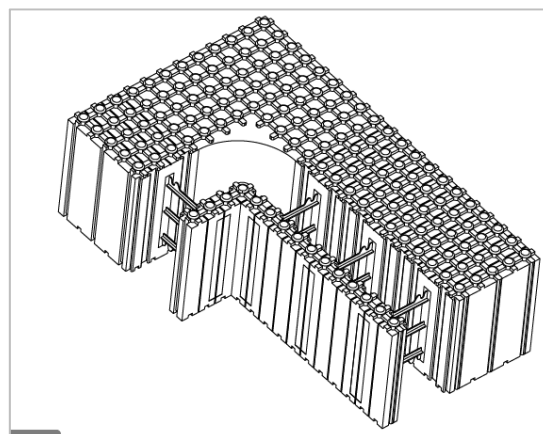
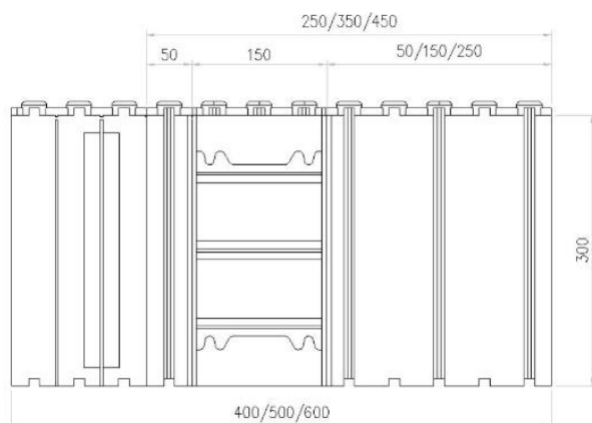

elements	dimensions l x h x t [mm]	outer leaf t [mm]
MC 50 PLUS K	800x300x400	50
MC 150 PLUS K	900x300x500	150
MC 250 PLUS K	1000x300x600	250
Thickness	inner leaf	t = 50mm
	concrete core	t = 150mm

Sketches not to scale  
All dimensions in [mm]

BEWI IFC SystemBEWI IFC SystemShuttering kit "BEWI"

BEWI PLUS kit - corner wall block PLUS - MC \_\_ Plus K  
t = 250/350/450mm

Annex A9

### Spacer for BEWI PLUS kit

Plastic tie of BEWI main wall PLUS  
and corner wall block PLUS

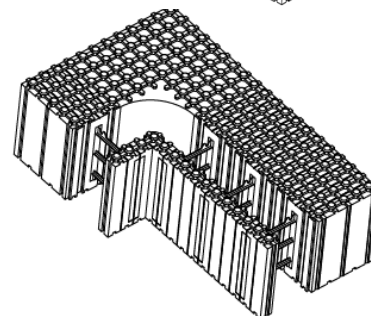
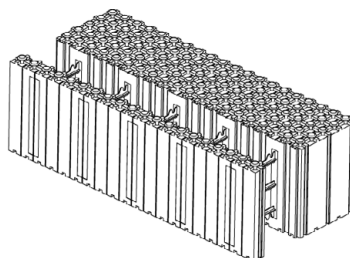
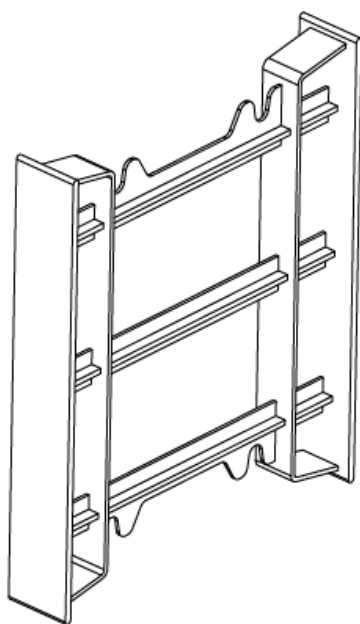
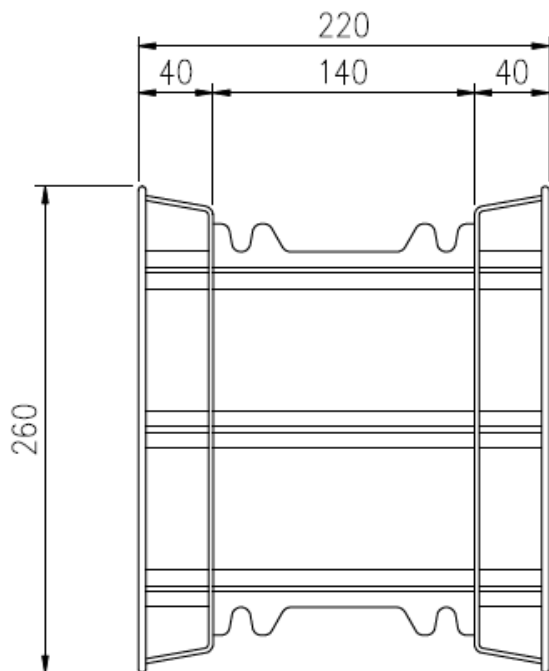

Sketches not to scale  
All dimensions in [mm]

BEWI IFC SystemBEWI IFC SystemShuttering kit "BEWI"

BEWI PLUS kit - PP tie / spacer

Annex 10

English translation prepared by DIBt

Description to BWR 1

A trial structure according to EAD 340309-00-0305, section 2.2.2 was erected. This structure comprised both element types: Standard blocks and PLUS blocks. The used elements are part of the 150-series. The structure incorporated reinforcement and following specifics:

- Corners
- T-junction of walls
- a Window and
- a Door.

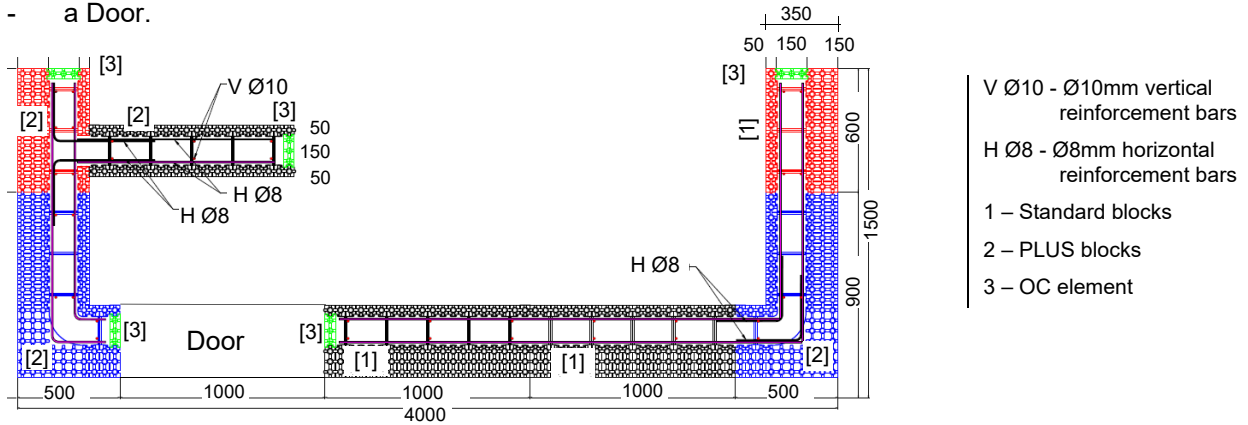

Figure 1: sketch Layer 1 of trial structure, sketch

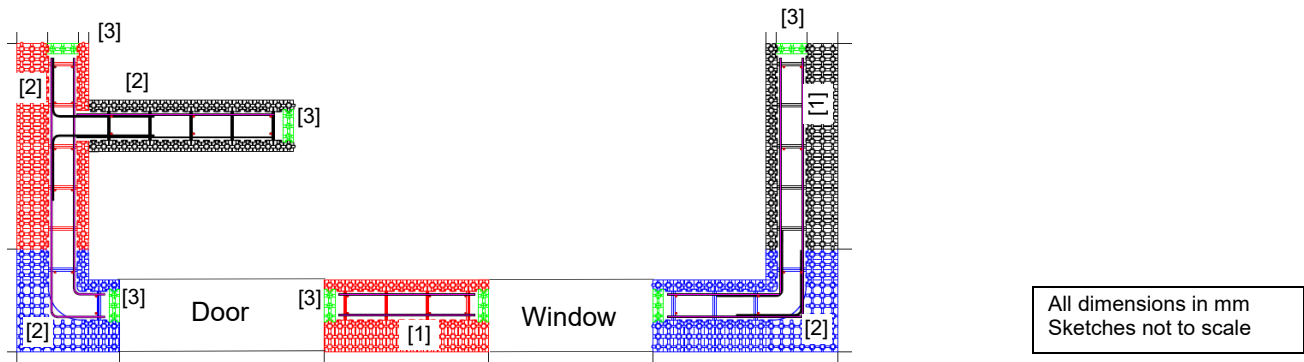

Figure 2: sketch Layer 4 of trial structure, sketch

The concrete used is EN 206-C16/20-XC1(LT)-CI0,40-Dmax16, S3. A maximum of 4 layers of elements were filled with concrete in one step.

For placing reinforcement national rules and guidelines shall prevail.

The following conclusions can be drawn:

**Efficiency of filling** Considering the instructions of Annex A1 and the installation guide of the ETA holder the tight and complete filling of the shuttering wall and an appropriate setting and hardening of the concrete is possible.

**Possibility of steel reinforcement** The instructions in the installation guide of the ETA holder are appropriate to install steel reinforcement for walls according to EN 1992-1-1 or corresponding national rules.

Shuttering kit "BEWI"	Annex B1
Description of Performance to BWR 1	

## Description to BWR 4

### Bond Strength

The shuttering leaves are single layered, hence there is no determination of the bond strength between shuttering leaves.

The EPS shuttering leaf is bonded to the concrete by mechanical interlocking of the T guides [figure 2.2.10.2.1 (b) in EAD 340309-00-0305, chapter 2.2.10.2]. The T-guides run vertically, full height on the inner surfaces of the leaf at 5 cm centres.  $\sigma_{mt, csl}$  is determined by calculation, using  $\sigma_{mt}$ .

$$\sigma_{mt, csl} = \sigma_{mt} \cdot A_{mt} / A$$

$$\sigma_{mt} = 280 \text{ kPa} \quad (\text{determined by testing according to EN 1607})$$

Standard Block (figure 3)

$\sigma_{mt, csl} > 450 \text{ kPa}$  according to EN 1607

PLUS Block (figure 4)

$\sigma_{mt, csl} > 420 \text{ kPa}$  according to EN 1607

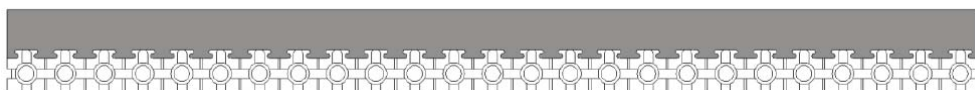

Figure 3: sketch bond Standard Block leaf and concrete

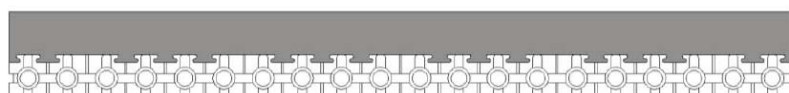

Figure 4: sketch bond PLUS Block leaf and concrete

### Resistance to filling pressure

The Standard Blocks resist a concrete pressure of  $p_{max} = 0,023 \text{ MPa}$

The PLUS Blocks resist a concrete pressure of  $p_{max} = 0,028 \text{ MPa}$

BEWI IFC System Shuttering kit "BEWI"

Description of Performance to BWR 4

Annex B2

Description to BWR 6

The values in Table 1 are determined for the wall, consisting of EPS shuttering elements filled with concrete.

Table 1: Thermal resistance  $R_D$  in  $m^2K/W$  according to EN ISO 6946/ EN ISO 10211<sup>\*)</sup>

System / element	$R_D$ in $m^2K / W$ For a thickness of the outer leaf [mm] of / [resulting wall thickness in mm]			
	50 / [250]	100 / [300]	150 / [350]	200 / [400]
Standard kit				
MC __	3,193	4,700	6,240	7,741
ML __	3,335	4,864	6,409	7,912
MP __	1,515 <sup>**)</sup>	3,030 <sup>**)</sup>	4,545 <sup>**)</sup>	6,060 <sup>**)</sup>
PLUS kit	50 / [250]		150 / [350]	250 / [450]
MC __ Plus (K)	3,090		6,121	9,151
Additional Elements				
	Additional elements, insert elements, plugs $R_D = 1,151 m^2K / W$			

\*) The thermal resistance has been determined by using a value of  $\lambda_D = 0.033 W/(m \cdot K)$  for the thermal conductivity of the EPS layers and  $\lambda_D = 2.5 W/(m \cdot K)$  for the concrete infill. Surface resistances  $R_{si}$  and  $R_{se}$  according to EN ISO 6946, chapter 6.7.1.2 are not considered.

\*\*\*) declared value for the outer leave, resistance of the slab is omitted

BEWI IFC SystemShuttering kit "BEWI"

Description of Performance to BWR 6

Annex B3