

Approval body for construction products
and types of construction

Bautechnisches Prüfamt

An institution established by the Federal and
Laender Governments



European Technical Assessment

ETA-05/0194
of 12 January 2024

English translation prepared by DIBt - Original version in German language

General Part

Technical Assessment Body issuing the
European Technical Assessment:

Deutsches Institut für Bautechnik

Trade name of the construction product

WDV-System EPS ZH

Product family
to which the construction product belongs

Product area code: 4
External Thermal insulation Composite System with
rendering
on expanded polystyrene for the use as external
insulation of building walls

Manufacturer

Brillux GmbH & Co. KG
Weseler Straße 401
48163 Münster
DEUTSCHLAND

Manufacturing plant

Brillux GmbH & Co. KG
Weseler Straße 401
48163 Münster
DEUTSCHLAND

This European Technical Assessment
contains

20 pages including 6 annexes which form an integral part
of this assessment

This European Technical Assessment is
issued in accordance with Regulation (EU)
No 305/2011, on the basis of

040083-00-0404

This version replaces

ETA-05/0194 issued on 26 April 2018

The European Technical Assessment is issued by the Technical Assessment Body in its official language. Translations of this European Technical Assessment in other languages shall fully correspond to the original issued document and shall be identified as such.

Communication of this European Technical Assessment, including transmission by electronic means, shall be in full. However, partial reproduction may only be made with the written consent of the issuing Technical Assessment Body. Any partial reproduction shall be identified as such.

This European Technical Assessment may be withdrawn by the issuing Technical Assessment Body, in particular pursuant to information by the Commission in accordance with Article 25(3) of Regulation (EU) No 305/2011.

Specific Part

1 Technical description of the product

This product is an External Thermal Insulation Composite System (ETICS) with rendering - a kit comprising components which are factory-produced by the manufacturer or component suppliers. It's made up on site from these. The ETICS manufacturer is ultimately responsible for all components of the ETICS specified in this ETA.

The ETICS kit comprises a prefabricated insulation product of expanded polystyrene (EPS) to be bonded and if it necessary additionally mechanically fixed onto a wall. The methods of fixing and the relevant components are specified in annex 1.

The insulation product is faced with a rendering system consisting of one base coat and finishing coat (site applied), in which the base coat contains reinforcement. The rendering is applied directly to the insulating panels, without any air gap or disconnecting layer.

The ETICS may include special fittings (e.g. base profiles, corner profiles ...) for connection to adjacent building elements (apertures, corners, parapets ...). Assessment and performance of these components are not addressed in this ETA, however the ETICS manufacturer is responsible for adequate compatibility and performance within the ETICS when the components are delivered as a part of the kit.

2 Specification of the intended use in accordance with the applicable European assessment Document (hereinafter called EAD)

The performances in Section 3 can only be assumed if the ETICS is used in accordance with the specifications and under the boundary conditions specified in Annexes 2 to 5.

The verifications and assessment methods on which this ETA is based lead to the assumption of a working life of the ETICS "WDV-System EPS ZH" of at least 25 years. The indications given on the working life cannot be interpreted as a guarantee given by the manufacturer, but are to be regarded only as a means for choosing the right products in relation to the assumed economically reasonable working life of the works.

For use, maintenance and repair, the finishing coat shall normally be maintained in order to fully preserve the ETICS performance. Maintenance includes at least:

- visual inspection of the ETICS,
- the repairing of localized damaged areas due to accidents,
- the aspect maintenance with products compatible with the ETICS (possibly after washing or ad hoc preparation).

Necessary repairs are to be carried out as soon as the need has been identified.

The information on use, maintenance and repair is given in the manufacturer's technical documentation.

It is the responsibility of the manufacturer to ensure that this information is made known to the concerned people.

3 Performance of the product and references to the methods used for its assessment

3.1 Safety in case of fire (BWR 2)

Essential characteristic	Performance
Reaction to fire of the ETICS	(see annex 2) Euroclass according to EN 13501-1
Reaction to fire of the EPS insulation product <ul style="list-style-type: none"> - Apparent density EN 1602 of the EPS insulation product according to EN 1602 	(see annex 2) Euroclass E according EN 13501-1 $\rho_a \leq 25 \text{ kg/m}^3$
Reaction to fire of the PU- foam adhesive	(see annex 2) Euroclass E according EN 13501-1
Facade fire performance	no performance assessed

3.2 Hygiene, health and environment (BWR 3)

Essential characteristic	Performance
Release of dangerous substances	no performance assessed
Water absorption Base coat after 1 hour after 24 hours	(see annex 3.1) Average [kg/m ²] Average [kg/m ²]
Rendering system after 1 hour after 24 hours	Average [kg/m ²] Average [kg/m ²]
EPS insulation product after 24 h	maximum value 0.5 kg/m ²
Water-tightness of the ETICS Hygrothermal behaviour on the test wall	Pass without defects
Water-tightness of the ETICS: Freeze/thaw behaviour	The water absorption of the base coats as well as the rendering systems is less than 0.5 kg/m ² after 24 h for all configurations of the ETICS. The ETICS is so assessed as free/thaw resistant.
Impact resistance	(see annex 3.2) Category
Water vapour permeability - Rendering system	(see annex 3.3) s _d value [m]
- EPS insulation product	$\mu = 20-70$ Thickness of the insulation product 400 mm

3.3 Safety and accessibility in use (BWR 4)

Essential characteristic	Performance
<p>Bond strength between base coat and EPS insulation product</p> <p>between adhesive and substrate</p> <p>between adhesive and EPS insulation</p> <p>of the foam adhesive</p>	<p>(see annex 4.1)</p> <ul style="list-style-type: none"> - Minimal value/ average value [kPa], rupture type: Initial state (28 d immersion) - Minimal value/ average value [kPa], rupture type: after hygrothermal cycles <p>(see annex 4.2)</p> <ul style="list-style-type: none"> - Thickness [mm] of the used adhesives - Minimal value/ average value [kPa], rupture type: <ul style="list-style-type: none"> Initial state (dry conditions) - Minimal value/ average value [kPa], rupture type: <ul style="list-style-type: none"> after 2 d immersion in water, 2 h drying - Minimal value/ average value [kPa], rupture type: <ul style="list-style-type: none"> after 2 d immersion in water, 7 d drying <p>(see annex 4.3)</p> <ul style="list-style-type: none"> - Thickness [mm] of the used adhesives - Minimal value/ average [kPa], rupture type: <ul style="list-style-type: none"> Initial state (dry conditions) - Minimal value/ average value [kPa], rupture type: <ul style="list-style-type: none"> after 2 d immersion in water, 2 h drying - Minimal value/ average value [kPa], rupture type: <ul style="list-style-type: none"> after 2 d immersion in water, 7 d drying <p>(see annex 4.4)</p> <ul style="list-style-type: none"> - Minimal value/ average value [kPa]
Fixing strength (displacement test)	Test not required therefore no limitation of ETICS length required.
Wind load resistance of ETICS pull-through test of fixing static foam block test	<p>(see annex 4.5)</p> <ul style="list-style-type: none"> - R_{panel} [kN/fixing], - R_{joint} [kN/fixing], - Plate diameter of anchor ≥ 60 mm resp. ≥ 90 mm - plate stiffness ≥ 0.3 kN/mm² - load resistance of the anchor plate ≥ 0.1 kN
Tensile strength perpendicular to the faces in dry conditions standard EPS	<p>$\sigma_{mt} \geq 80$ kPa (bonded ETICS)</p> <p>$\sigma_{mt} \geq 100$ kPa (mechanically fixed ETICS with supplementary adhesive)</p> <p>$\sigma_{mt} \geq 150$ kPa (bonded ETICS with profiles)</p> <p>$\sigma_{mt} \geq 80$ kPa (bonded ETICS, mechanically fixed ETICS with supplementary adhesive)</p>
elastified EPS	

Essential characteristic	Performance
Shear strength of the ETICS	$20 \leq f_{rk} \leq 170$ kPa
Shear modulus of the ETCS standard EPS elastified EPS	$1.0 \leq G_m \leq 3.8$ MPa $0.3 \leq G_m \leq 1.0$ MPa
Pull-through resistance of fixings from profiles	$\geq 0,5$ kN
Render strip tensile test	(see annex 4.6) crack width w_{rk} [mm]
shear strength of foam adhesive	- Minimal value: 81 kPa - average value: 87 kPa
shear modulus of foam adhesive	- Minimal value: 0,754 MPa - average value: 0,89 MPa
Post expansion behaviour of foam adhesive	max. 14 mm
Bond strength after ageing finishing coat tested on the rig finishing coat not tested on the rig	(see annex 4.7) Minimal value/ average value [kPa], rupture type Minimal value/ average value [kPa], rupture type
Tensile strength of the glass fibre mesh in the as-delivered state	(see annex 4.8) Average value [N/mm]
Residual tensile strength of the glass fibre mesh after aging	(see annex 4.8) Average value [N/mm]
Relative residual tensile strength of the glass fibre mesh after aging	(see annex 4.8) Average value [%]
Elongation of the glass fibre mesh in the as-delivered state	(see annex 4.8) Average value [N/mm]
Elongation of the glass fibre mesh after aging	(see annex 4.8) Average value [%]

3.4 Protection against noise (BWR 5)

Essential characteristic	Performance
Airborne sound insulation of ETICS	no performance assessed
Dynamic stiffness of the EPS insulation product	no performance assessed
Air flow resistance of the EPS insulation product	no performance assessed

3.5 Energy economy and heat retention (BWR 6)

Essential characteristic	Performance
Thermal resistance of ETICS	(see annex 5) Calculated value or measurement value R [(m ² · K)/W]
Thermal transmittance of ETICS	(see annex 5) Calculated value or measurement value U [W/(m ² · K)]

English translation prepared by DIBt

4 Assessment and verification of constancy of performance (AVCP) system applied, with reference to its legal base

In accordance with EAD No. 040083-00-0404 the applicable European legal act is: [97/556/EC changed by 2001/596/EC

The systems to be applied are:

Product	Intended use	Levels or classes (Reaction to fire)	Systems
"WDV-System EPS ZH"	ETICS in external wall subject to fire regulations	A1 ⁽¹⁾ , A2 ⁽¹⁾ , B ⁽¹⁾ , C ⁽¹⁾	1
		A1 ⁽²⁾ , A2 ⁽²⁾ , B ⁽²⁾ , C ⁽²⁾ , D, E, (A1 to E) ⁽³⁾ , F	2+
	ETICS in external wall not subject to fire regulations	any	2+
<p>⁽¹⁾ Products/materials for which a clearly identifiable stage in the production process results in an improvement of the reaction to fire classification (e. g. an addition of fire retardants or a limiting of organic material)</p> <p>⁽²⁾ Products/materials not covered by footnote (1)</p> <p>⁽³⁾ Products/materials that do not require to be tested for reaction to fire (e.g.products/materials of Classes A1 according to Commission Decision 96/603/EC)</p>			

5 Technical details necessary for the implementation of the AVCP system, as provided for in the applicable European Assessment Document

Technical details necessary for the implementation of the AVCP system are laid down in the control plan deposited at Deutsches Institut für Bautechnik.

Issued in Berlin on 12 January 2024 by Deutsches Institut für Bautechnik

Anja Rogsch
Head of Section

beglaubigt:
Keküllüoglu

Annex 1

Composition of the ETICS

	Components National application documents shall be taken into account	Coverage [kg/m ²]	Thickness [mm]
Insulation material with associated method of fixing	Bonded ETICS: <ul style="list-style-type: none"> • Insulation product factory-prefabricated expanded polystyrene (EPS) * <ul style="list-style-type: none"> - standard-EPS - elastified EPS • Adhesives <ul style="list-style-type: none"> - WDVS Pulverkleber (cement based powder requiring addition of about 24 % of water) • Foam Adhesive <ul style="list-style-type: none"> - WDVS Qju Klebeschaum (foam adhesive on polyurethane, ready to use, in bottles supplied) 	 – – about 4.0 (powder) 0.20 l/m ²	 ≤ 400 ≤ 200 – –
	Mechanically fixed ETICS with profiles and supplementary adhesive: <ul style="list-style-type: none"> • Insulation product factory-prefabricated expanded polystyrene (EPS) * <ul style="list-style-type: none"> - standard EPS • Supplementary adhesive (equal to bonded ETICS) • Profile <ul style="list-style-type: none"> - WDVS Halteleiste - WDVS Verbindungsleiste Polyvinyl chloride (PVC) profiles • Anchors for profiles <ul style="list-style-type: none"> - WS 8 L - WS 8 N - ejothem SDK U - SDF-K plus - ejothem NK U 	–	60 to 200
	Mechanically fixed ETICS with anchors and supplementary adhesive: <ul style="list-style-type: none"> • Insulation product factory-prefabricated expanded polystyrene (EPS)* <ul style="list-style-type: none"> - standard EPS - elastified EPS 	 – –	 60 to 400 60 to 200

	Components National application documents shall be taken into account	Coverage [kg/m ²]	Thickness [mm]
	<ul style="list-style-type: none"> • Supplementary adhesive (equal to bonded ETICS) • Anchors for insulation product anchors with ETA according to EAD330196-01-0604¹ 		
Base coat	<p>WDVS Pulverkleber</p> <p>Qjusion Mineral</p>	<p>about 4.5 (powder)</p> <p>about 4.5 (prepared)</p>	<p>about 3.0</p> <p>about 3.0</p>
Glass fibre mesh	<p>WDVS Glasseidengewebe Alkali- and slide-resistant glass fibre mesh with mass per unit area of about 160 g/m² and mesh size of about 4.0 mm x 4.0 mm</p> <p>WDVS Panzergewebe (reinforced mesh implemented in addition to the mesh described above to improve the impact resistance) Alkali- and slide-resistant glass fibre mesh with mass per unit area of about 530 g/m²</p>	<p>–</p> <p>–</p>	<p>–</p> <p>–</p>
Key coat	<p>Putzgrundierung Ready to use pigmented liquid – vinylic binder:</p> <p>Silicon-Putzgrundierung Ready to use pigmented liquid – vinylic-siloxane binder</p> <p>Silikat-Streichfüller Ready to use pigmented liquid – acrylic/silicate binder For the compatibility with the finishing coats see below.</p>	<p>about 0.25 l/m²</p> <p>about 0.25 l/m²</p> <p>about 0.25 l/m²</p>	<p>–</p> <p>–</p> <p>–</p>

¹ EAD330196-01-0604

Plastic anchors made of virgin or non-virgin material for fixing of external thermal insulation composite systems with rendering (and previous versions)

	Components National application documents shall be taken into account	Coverage [kg/m ²]	Thickness [mm]
Finishing coat	<ul style="list-style-type: none"> Thin layered cement based powder requiring addition of about 30 % (structure KR / R) of water and of about 48 % (structure G) of water: Mineral-Leichtputz KR/R** (particle size 1 – 2 – 3 – 4 and 5 mm) Mineral-Leichtputz G To use with key coat "Putzgrundierung" if applicable *** Ready to use paste – acrylic/silicate binder: Silikat-Putz KR/R ** (particle size 1 – 2 – 3 – 4 and 5 mm) To use with "Silikat-Streichfüller" *** Ready to use paste - vinylic binder: Rausan KR/R ** (particle size 1 – 2 – 3 – 4 and 5 mm) To use with "Putzgrundierung" *** Ready to use paste – vinylic-siloxane binder: Silicon-Putz KR/R ** (particle size 1 – 2 – 3 – 4 and 5 mm) Silcosil KR/R ** (particle size 1 – 2 – 3 – 4 and 5 mm) To use with "Silicon Putzgrundierung" **** Ready to use paste – acrylic binder – associated with synthetic briquettes: Klebemörtel with Flachverblender To use with "Silicon Putzgrundierung" *** 	<p>about 2.5 to 5.0 (powder)</p> <p>about 2.5 to 5.0 (powder)</p> <p>about 2.5 to 6.0</p> <p>2.5 to 5.0</p> <p>2.5 to 5.0</p> <p>2.5 to 5.0</p> <p>3.0 to 4.0 5.0 to 6.0</p>	<p>Regulated by particle size</p> <p>3.0 to 5.0</p> <p>Regulated by particle size</p> <p>1.0 to 2.0 about 5.0</p>
Ancillary material	Remains the responsibility of the manufacturer of ETICS.		
<p>* Factory-prefabricated, uncoated panels made of expanded polystyrene (EPS) to EN 13163 shall be used. ** KR / R indicates different structures of the finishing coat/s. *** The instruction to the installer concerning the use of a key coat remains the responsibility of the manufacture.</p>			

Annex 2
Safety in case of fire (BWR 2)
Reaction to fire

Configuration	Organic content	Flame retardant content	Euroclass according to EN 13501-1
foam adhesive	max. 100 %	min. 3.7 %	
Base coat	max. 4.0 %	no flame retardant	
EPS insulation product	Euroclass E according to EN 13501-1	Euroclass E according to EN 13501-1	
profiles	-	-	
anchors	-	-	
rendering system: Base coat with finishing coat and compatible key coat indicated in annex 1			
Putzgrundierung with Mineral-Leichtputz KR/R/G	max. 3.7 %	no flame retardant	B – s1, d0
Silikat-Streichfüller with Silikat-Putz KR/R	max. 4.4 %		
Putzgrundierung with Rausan KR/R	max. 9.9 %	min. 12.8 %	B – s2, d0
Silicon Putzgrundierung with Silicon-Putz KR/R			
Silicon Putzgrundierung with Silcosil KR/R			
Putzgrundierung with Klebemörtel and Flachverblender	max. 9.9 %	min. 9.0 %	

Annex 3

Hygiene, health and environment (BWR 3)

3.1 Water absorption (capillarity test)

Base coat:

base coat	Average water absorption [kg/m ²]	
	after 1h	after 24h
WDVS Pulverkleber	0.037	0.166
Qjusion Mineral	0.027	0.169

Rendering system:

Rendering system: Base coat "WDVS Pulverkleber" or "Qjusion Mineral" with finishing coat and compatible key coat indicated hereafter	Average water absorption [kg/m ²]			
	after 1h		after 24h	
	"WDVS Pulverkleber"	"Qjusion Mineral"	"WDVS Pulverkleber"	"Qjusion Mineral"
Mineral-Leichtputz KR/R/G	0.138	0.102	0.264	0.418
Silikat-Streichfüller with Silikat-Putz KR/R	0.168	0.128	0.430	0.458
Putzgrundierung with Rausan KR/R	0.145	0.111	0.388	0.388
Silicon Putzgrundierung with Silicon-Putz KR/R	0.049	0.089	0.281	0.371
Silicon Putzgrundierung with Silcosil KR/R	0.093	0.070	0.348	0.398
Putzgrundierung with Klebemörtel and Flachverblender	0.038	0.018	0.332	0.182

3.2 Impact resistance (tested on small samples)

Rendering system: Base coat "WDVS Pulverkleber" or "Qjusion Mineral" with finishing coat and compatible key coat indicated hereafter	"WDVS Glasseidengewebe"		
	single mesh	double mesh	+ WDVS Panzergewebe
base coat: Qjusion Mineral Mineral-Leichtputz KR/R/G	category III	category II	category I
base coat: WDVS Pulverkleber Mineral-Leichtputz KR/R/G	category II		
Silikat-Streichfüller with Silikat-Putz KR/R			
Putzgrundierung with Rausan KR/R			
Silicon Putzgrundierung with Silicon-Putz KR/R			
Silicon Putzgrundierung with Silcosil KR/R			
Putzgrundierung with Klebemörtel and Flachverblender			

3.3 Water vapour permeability ETICS

Rendering system: Base coat "WDVS Pulverkleber" or "Qjusion Mineral" with finishing coat and compatible key coat indicated hereafter	Equivalent air thickness s_d [m]
Mineral-Leichtputz KR/R/G	≤ 1.0 m (Test result obtained with structure KR t = 3 mm: 0.2 m)
Silikat-Streichfüller with Silikat-Putz KR/R	≤ 1.0 m (Test result obtained with structure KR t = 3 mm: 0.2 m)
Putzgrundierung with Rausan KR/R	≤ 1.0 m (Test result obtained with structure KR t = 3 mm: 0.3 m)
Silicon Putzgrundierung with Silicon- Putz KR/R	≤ 1.0 m (Test result obtained with structure KR t = 3 mm: 0.3 m)
Silicon Putzgrundierung with Silcosil KR/R	≤ 1.0 m (Test result obtained with structure KR t = 3 mm: 0.3 m)
Putzgrundierung with Klebemörtel and Flachverblender	≤ 1.0 m (Test result: 0.6 m)

Annex 4

Safety and accessibility in use (BWR 4)

4.1 Bond strength between base coat and insulation product (EPS)

		Conditioning		
		Initial state [kPa]	After hygrothermal cycles [kPa]	After freeze/thaw test
WDVS Pulverkleber 3550	Average	102	86	Test not required because freeze/thaw cycles not necessary
	Minimal value	93	60*	
Qjusion Mineral	Average	127	108	
	Minimal value	116	93	

* partial break into the insulation product and partial break into the base coat

4.2 Bond strength between adhesive and substrate

Substrate: concrete		Rupture type	Conditioning		
			Initial state [kPa]	2 d immersion in water and 2 hrs. drying [kPa]	2 d immersion in water and 7 d drying [kPa]
WDVS Pulverkleber (3 – 5 mm)	Average	in adhesive	880	462.8	1142.5
	Minimal value		440	391.4	929.2

4.3 Bond strength between adhesive and insulation product (EPS)

		Rupture type	Conditioning		
			Initial state [kPa]	2 d immersion in water and 2 hrs. drying [kPa]	2 d immersion in water and 7 d drying [kPa]
WDVS Pulverkleber (3 – 5 mm)	Average	in insulation product	103	121	96
	Minimal value		86	91	90

Minimal bonded surface area

$$S [\%] = 0.03 \text{ N/mm}^2 \times 100 / 0.08 \text{ N/mm}^2$$

$$S = 37.5\%$$

The minimal bonded surface S of bonded ETICS is 40%

4.4 Bond strength of foam adhesive

foam adhesive		Standard application conditions [kPa]	Modification of foam thickness [kPa]	Modification of processing time (open time 5 min) [kPa]	Modification of temperature (low temperature) [kPa]	Modification of temperature (low temperature) [kPa]
WDVS Qju Klebe- schaum	Average	120	89	131	85	82
	Minimal value	110.1	77.1	124.2	77.6	74.6

4.5 Wind load resistance

The following failure loads only apply to the listed combination of component characteristics and the characteristics of the insulation product.

4.5.1 Safety in use of mechanically fixed ETICS using profiles

Characteristics of the EPS (standard EPS)	Dimensions	500 mm x 500 mm
	Thickness	≥ 60 mm
	Tensile strength perpendicular to the faces	≥ 150 kPa
	Shear modulus	≥ 1.0 N/mm ²
Failure load [kN / panel] (Static Foam Block Test)	Horizontal profiles fixed every 30 cm and 49.4 cm long vertical connection profiles	Minimal: 0.095 Average: 0.101

4.5.2 Safety in use of mechanically fixed ETICS using anchors

Apply to all anchors listed in annex 1 mounted on the insulation panels surface				
Characteristics of the EPS (standard EPS)	Thickness	≥ 60 mm		
	Tensile strength perpendicular to the faces	≥ 100 kPa		
	Shear modulus	≥ 1.0 N/mm ²		
Plate diameter of anchor	Ø 60 mm	Ø 90 mm		
plate stiffness	≥ 0.3 kN/mm			
load resistance of the anchor plate	≥ 1.0 kN			
Failure load [kN]	Anchors not placed at the panel joints (Static Foam Block Test)	R _{panel}	Minimal: 0.51 Average: 0.52	Minimal: 0.72 Average: 0.73
	Anchors placed at the panel joints (Pull-through test)	R _{joint}	Minimal: 0.40 Average: 0.43	Minimal: 0.43 Average: 0.47

Apply to all anchors listed in annex 1 mounted on the insulation panels surface		
Characteristics of the EPS (elastified EPS)	Thickness	≥ 60 mm
	Tensile strength perpendicular to the faces	≥ 80 kPa
	Shear modulus	≥ 0.3 N/mm ²
Plate diameter of anchor		∅ 60 mm
plate stiffness		≥ 0.3 kN/mm
load resistance of the anchor plate		≥ 1.0 kN
Failure load [kN]	Anchors not placed at the panel joints (Static Foam Block Test)	R _{panel} Minimal: 0.35 Average: 0.36
	Anchors placed at the panel joints (Pull-through test)	R _{joint} Minimal: 0.30 Average: 0.31

The failure loads specified above for a plate diameter of anchor of 60 mm apply to the following anchors with deep mounting but only on the following conditions of installation:

Anchor	Thickness of the EPS panel [t]	Conditions of installation *
ejothem STR U (ETA-04/0023)	t ≥ 80 mm	– Maximum installation depth of the anchor plate: 15 mm (≙ thickness of insulation cover) – Incision depth: 20 mm
	t ≥ 100 mm	– Maximum installation depth of the anchor plate: 15 mm (≙ thickness of insulation cover) – Incision depth: 35 mm
* according to the appropriate ETA of anchor		

4.6 Render strip tensile test

The average value of crack width of the base coats reinforced with the different glass fibre meshes measured at a render strain value of 1 % is:

Base coat	Glass fibre mesh	Average value of crack width W _{m(1%)}
WDVS Pulverkleber	WDVS Glasseidengewebe	0.07 mm
Qjusion Mineral	WDVS Glasseidengewebe	0.04 mm

4.7 Bond strength after aging

Rendering system: Base coat "WDVS Pulverkleber" or "Qjusion Mineral" with finishing coat and compatible key coat indicated hereafter		After hygrothermal cycles [kPa] with base coat		7 d immersion in water and 7 d drying [kPa] with base coat	
		"WDVS Pulverkleber"	"Qjusion Mineral"	"WDVS Pulverkleber"	"Qjusion Mineral"
Mineral- Leichtputz KR/R/G	Average			115	127
	Minimal value			96	107
Silikat- Streichfüller with Silikat-Putz KR/R	Average			104	136
	Minimal value			50	91
Putzgrundierung with Rausan KR/R	Average	87	104		
	Minimal value	60	90		
Silicon Putzgrundierung with Silicon-Putz KR/R	Average	90	110		
	Minimal value	61	91		
Silicon Putzgrundierung with Silcosil KR/R	Average			130	115
	Minimal value			112	97
Putzgrundierung with Klebemörtel and Flachverblender	Average			185.8	104
	Minimal value			165.6	88

4.8 Reinforcement (glass fibre mesh)

WDVS Glasseidengewebe	Average warp	Average weft
Tensile strength in as-delivered state	2071 N / 50 mm	2189 N / 50 mm
Residual tensile strength after aging	1083 N / 50 mm	1261 N / 50 mm
Relative residual tensile strength after aging	53.0 %	57.0 %
Elongation in as-delivered state	3.8 %	3.9 %
Elongation after aging	2.3 %	2.5 %

WDVS Panzergewebe	Average warp	Average weft
Tensile strength in as-delivered state	4976 N / 50 mm	8501 N / 50 mm
Residual tensile strength after aging	3110 N / 50 mm	5006 N / 50 mm
Relative residual tensile strength after aging	62.0 %	59.0 %
Elongation in as-delivered state	3.2 %	3.5 %
Elongation after aging	2.6 %	2.8 %

Annex 5

Energy economy and heat retention (BWR6)

5.1 Energy economy and heat retention (BWR 6)

The nominal value of the additional thermal resistance R provided by the ETICS to the substrate wall is calculated in accordance with EN ISO 6946 from the nominal value of the insulation product's thermal resistance R_D given accompanied to the CE marking and from the thermal resistance of the rendering system R_{render} which is about $0.02 (m^2 \cdot K)/W$.

$$R = R_D + R_{render}$$

The thermal bridges caused by mechanical fixing (anchors, profiles) increases the thermal transmittance U. This influence had to take into account according to EN ISO 6946

$$U_c = U + \chi_p \cdot n$$

- Where:
- U_c : corrected thermal transmittance [$W/(m^2 \cdot K)$]
 - n : number of anchors per m^2
 - χ_p : local influence of thermal bridge caused by an anchor. The values listed below can be taken into account if not specified in the anchor's ETA:
 - $\chi_p = 0.004 W/K$ for anchors with a galvanized steel screw with the head covered by a plastic material
 - $\chi_p = 0.002 W/K$ for anchors with a stainless steel screw covered by plastic anchors and for anchors with an air gap at the head of the screw

The thermal bridges caused by profiles are negligible.

Annex 6

Profiles

Polyvinyl chloride (PVC) profiles, PVC-U, EGL, 082-05-T33 to EN ISO 1163-1:1999 are to be used in the mechanically fixed ETICS with profiles. The Pull-through resistance of fixings from profiles is ≥ 500 N.

Horizontal profile – "WDVS Halteleiste" (dimensions in millimetres)

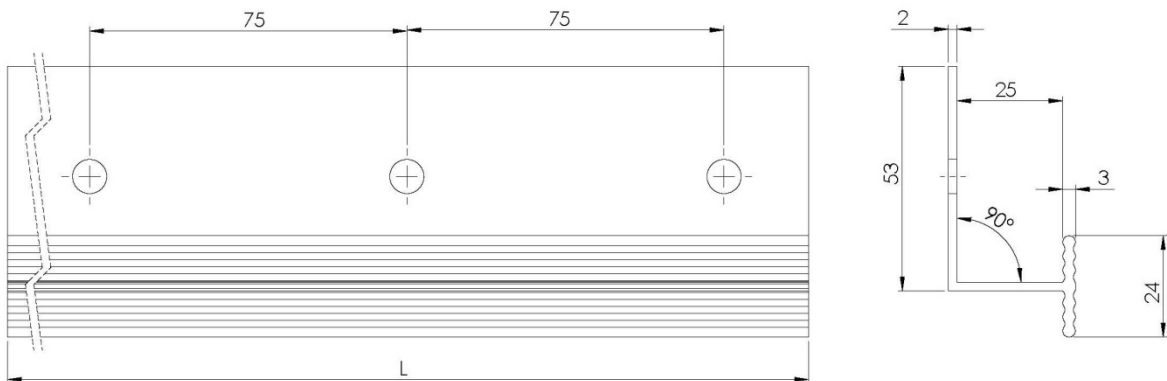

Vertical connection profile "WDVS Verbindungsleiste" (dimensions in millimetres)

